



(11) **EP 1 939 904 A2**

(12) **EUROPEAN PATENT APPLICATION**

(43) Date of publication:
02.07.2008 Bulletin 2008/27

(51) Int Cl.:
H01H 9/34 (2006.01)

(21) Application number: **07024416.5**

(22) Date of filing: **17.12.2007**

(84) Designated Contracting States:
AT BE BG CH CY CZ DE DK EE ES FI FR GB GR HU IE IS IT LI LT LU LV MC MT NL PL PT RO SE SI SK TR
Designated Extension States:
AL BA HR MK RS

(72) Inventor: **Yeon, Young-Myoung**
Cheoungju
Chungcheongbuk-do (KR)

(30) Priority: **29.12.2006 KR 20060139140**

(74) Representative: **Altenburg, Udo et al**
Patent- und Rechtsanwälte
Bardehle . Pagenberg . Dost .
Altenburg - Geissler
Galileiplatz 1
81679 München (DE)

(71) Applicant: **LS Industrial Systems Co., Ltd**
Jung-Gu
Seoul (KR)

(54) **Air circuit breaker with ARC extinguishing apparatus**

(57) An air circuit breaker with an arc extinguishing apparatus comprising: a frame having a receiving space (112) therein; a fixed contact (120) disposed inside the frame; a movable contact (130) disposed to be in contact with or separated from the fixed contact; and an extinguishing apparatus (150) which includes a chamber member disposed in the frame and having an outlet (153) formed at one side thereof, a plurality of grids (171) disposed in the chamber member to be spaced apart from one another, and a cloth filter member (180) formed of fabric and disposed between the outlet and the grids to prevent fragments which are generated by arcs from being scattered, whereby the air circuit breaker can be fabricated with low cost, and also fragments generated due to arcs can be prevented from being excessively scattered to the exterior.

FIG. 2

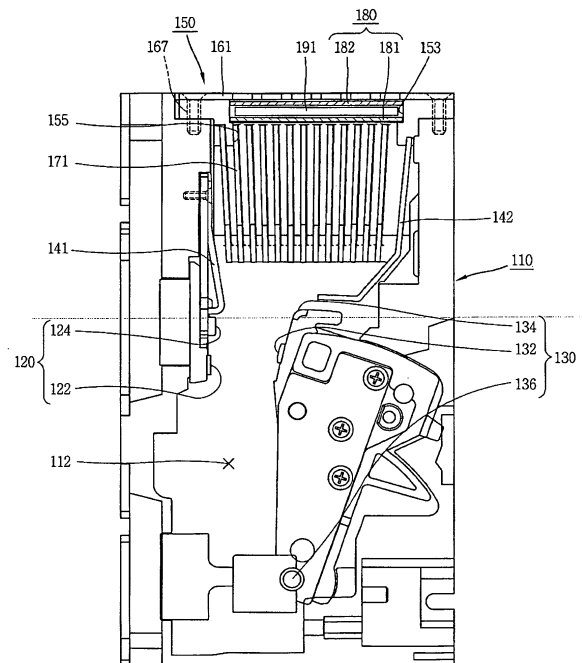

Description

BACKGROUND OF THE INVENTION

1. Field of the Invention

[0001] The present invention relates to an air circuit breaker with an arc extinguishing apparatus, and more particularly, to an air circuit breaker with an arc extinguishing apparatus capable of avoiding fragments generated during an arc extinguishing process from being scattered to the exterior without filtering.

2. Description of the Background Art

[0002] So-called circuit breaker refers to an electric protecting apparatus which is installed between power source and load equipment in order to protect the load equipment and a line from an abnormal current (a short circuit, excess current due to an earth fault, etc.) which may be generated in an electric circuit.

[0003] The circuit breakers may be classified, according to an arc extinguishing medium, into an oil circuit breaker (OCB), an air circuit breaker (ACB), a vacuum circuit breaker (VCB), or a gas circuit breaker (GCB).

[0004] Typically, the air circuit breaker may comprise fixed contact and movable contact which are installed to be in contact with or separated from each other, an opening/closing unit for opening/closing the movable contact, and an extinguishing apparatus for extinguishing arcs occurred when opening/closing the movable contact.

[0005] Fig. 1 is an exploded perspective view showing an extinguishing apparatus for a related art air circuit breaker. As shown in Fig. 1, the extinguishing apparatus for the air circuit breaker may comprise a chamber member 11 having both sides open and having an insertion groove 13 therein, a plurality of grids 21 inserted into the insertion groove 13, an insulating board 31 disposed at one side of the grids 21, a cooling board 41 disposed at one side of the insulating board 31, and an exhaust cover 51 coupled to the chamber member 11 at an outer side of the insulating board 31.

[0006] Arc runners 25 may be disposed at both sides of the grids 21 to induce arcs occurred when contacts are separated from each other toward the grids 21.

[0007] The insulating board 31 may be formed of an insulating material. A plurality of through holes 32 may be formed through a planar surface of the insulating board 31 so as to segment (disperse, distribute) arcs.

[0008] The cooling board 41 may be formed of metal, and have a plurality of through holes 42 formed through a planar surface thereof. The exhaust cover 51 may have a plurality of communication holes 52 to thusly be communicated with the exterior.

[0009] However, in the arc extinguishing apparatus of the related art air circuit breaker, when the arcs which have occurred during the separation of contacts to be induced to the grids 21 by the arc runners 25 increase

temperature and pressure between the grids 21, through holes 32 and 42 and the communication holes 52 are simply formed, respectively, through the planar surface of the insulating board 31 and the cooling board 41 and the exhaust cover 51, in order to discharge gases to the outside. Accordingly, part of fragments, which are generated when one area of the grid 21 is melted by arcs of high temperature, may excessively be discharged out of the extinguishing apparatus, without being filtered, through the through holes 32 and 42 and the communication holes 52.

[0010] In particular, the insulating board 31 is merely disposed at the side of the downstream of the grids 21 in a direction in which gases are discharged. Accordingly, gases or fragments generated when a metal is melted are scattered to the outside without passing through the through holes 32 of the insulating board 31. As a result, the gases or fragments may then be directly discharged to the outside through the communication holes 52 of the exhaust cover 51 without first passing through the through holes 42 of the cooling board 41, the communication hole having a relatively larger size than that of the through hole of the cooling board 41.

SUMMARY OF THE INVENTION

[0011] Therefore, in order to solve those problems of the related art, it is an object of the present invention to provide an air circuit breaker with an arc extinguishing apparatus capable of avoiding fragments generated due to arcs from being excessively scattered to the exterior.

[0012] Another object of the present invention is to provide an air circuit breaker with an arc extinguishing apparatus capable of facilitating an arc extinguishing and avoiding fragments generated due to arcs from being excessively scattered to the exterior.

[0013] Still another object of the present invention is to provide an air circuit breaker with an arc extinguishing apparatus capable of reducing fabrication cost and avoiding fragments generated due to arcs from being excessively scattered to the exterior.

[0014] To achieve these and other advantages and in accordance with the purpose of the present invention, as embodied and broadly described herein, there is provided an air circuit breaker with an arc extinguishing apparatus comprising: a frame having a receiving space therein; a fixed contact disposed inside the frame; a movable contact disposed to be in contact with or separated from the fixed contact; and an extinguishing apparatus which may comprise a chamber member disposed in the frame and having an outlet formed at one side thereof, a plurality of grids disposed in the chamber member to be spaced apart from one another, and a cloth filter member made of fabric and disposed between the outlet and the grids to prevent scattering of fragments generated when the grids are melted by arcs.

[0015] Here, the air circuit breaker may further comprise an arc runner connected to the fixed contact to in-

duce arcs to the extinguishing apparatus when the movable contact is separated from the fixed contact.

[0016] The cloth filter member may be implemented as a metallic cloth filter which is woven such that two wires are alternately arrayed up and down with each other.

[0017] The extinguishing apparatus may further comprise a porous plate disposed at one side of the cloth filter member along a direction in which gas is discharged.

[0018] The porous plate may be implemented as a metallic member, which facilitates arcs to be distributed and cooled.

[0019] Also, the porous plate may be implemented as an insulating member, such that arcs can be bypassed for movement.

[0020] The extinguishing apparatus may further comprise an exhaust cover having a plurality of communication holes formed through a planar surface thereof and coupled to the outlet. Here, the communication holes may be formed in the same size with a constant pitch therebetween so as to easily support the cloth filter member.

[0021] The cloth filter member may comprise a first filter and a second filter each of which is a metallic cloth filter woven by arraying two wires to be orthogonal to each other, the first and second filters being disposed to be spaced apart from each other along a direction in which gas is discharged.

[0022] The first and second filters may be configured to have air gaps with the same size or different sizes. The air gap of the second filter may be smaller than that of the first filter to thus prevent scattering of fragments more effectively.

[0023] The extinguishing apparatus may further comprise a porous plate disposed at one side either of the first filter or the second filter.

BRIEF DESCRIPTION OF THE DRAWINGS

[0024] The accompanying drawings, which are included to provide a further understanding of the invention and are incorporated in and constitute a part of this specification, illustrate embodiments of the invention and together with the description serve to explain the principles of the invention.

Figure 1 is an exploded perspective view showing an extinguishing apparatus of the related art air circuit breaker;

Figure 2 is a cross-sectional view showing an air circuit breaker with an arc extinguishing apparatus in accordance with one embodiment of the present invention;

Figure 3 is an enlarged perspective view of the extinguishing apparatus of Figure 2;

Figure 4 is a planar view showing a cloth filter member of Figure 3;

Figure 5 is a cross-sectional view taken along the line V-V of Figure 4;

Figure 6 is an enlarged cross-sectional view of main parts of Figure 2;

Figure 7 is a cross-sectional view showing an air circuit breaker with an arc extinguishing apparatus in accordance with another embodiment of the present invention;

Figure 8 is an enlarged perspective view of the extinguishing apparatus of Figure 7; and

Figure 9 is an enlarged cross-sectional view of main parts of Figure 7.

DETAILED DESCRIPTION OF THE INVENTION

[0025] Description will now be given in detail of the preferred embodiments of the present invention, examples of which are illustrated in the accompanying drawings.

[0026] Hereinafter, an air circuit breaker with an arc extinguishing apparatus will be described in detail in accordance with one embodiment of the present invention.

[0027] As shown in Fig. 2, the air circuit breaker with the arc extinguishing apparatus may comprise a frame 110 having a receiving space 112, a fixed contact 120 disposed inside the frame 110, a movable contact 130 disposed to be in contact with or separated from the fixed contact 120, and an extinguishing apparatus 150, which may include a chamber member 151 disposed in the frame 110 and having an outlet 153 formed at one side thereof, a plurality of grids 171 disposed inside the chamber member 151 to be spaced apart from one another, and a cloth filter member 180 made of fabric and disposed between the outlet 153 and the grids 171 to prevent scattering of fragments which are generated when the grids 171 are melted by arcs.

[0028] The frame 110 may have the receiving space 112 formed therein, and have an open portion formed at an upper end thereof to allow gas to be discharged there-through. The fixed contact 120 may be disposed at one side in the frame 110 in a longitudinal direction. The movable contact 130 may be installed at one side of the fixed contact 120 such that the movable contact 130 can be in contact with or separated from the fixed contact 120 by rotating in a longitudinal direction.

[0029] The fixed contact 120 may include a main contact point 122, and an arc contact point 124 formed at one side of the main contact point 122 to be spaced apart from the main contact point 122.

[0030] The movable contact 130 may include a main contact point 132 and an arc contact point 134 formed at one end portion of the movable contact 130 so as to be contactable to the main contact point 122 and the arc contact point 124 of the fixed contact 120, respectively, and a rotational shaft 136 may be disposed at the other end portion of the movable contact 130 such that the movable contact 130 rotates toward or away from the fixed contact 120.

[0031] A first arc runner 141 may be disposed at the fixed contact 120, thus to induce arcs, which occur when

the movable contact 130 rotated to be separated from the fixed contact 120, toward the extinguishing apparatus 150. A second arc runner 142 may be disposed at a side facing the first arc runner 141 of the extinguishing apparatus 150.

[0032] The extinguishing apparatus 150, as shown in Fig. 3, may comprise the chamber member 151 having a receiving space and having the outlet 153 formed at one side thereof to allow gas to be discharged there-through, a plurality of planar grids 171 disposed in the chamber member 151 to be spaced apart from one another, and the cloth filter member 180 made of fabric and disposed between the outlet 153 and the grids 171 to prevent fragments, which are generated from the side of the grids 171, from being discharged (scattered) to the outside through the outlet 153.

[0033] The chamber member 151, which is implemented as an insulating member, may have the receiving space therein. The chamber member 151 may have an approximately rectangular parallelepiped having the outlet 153 formed at an upper end thereof. The chamber member 151 may be installed at an open area of the frame 110 such that gas discharged through the outlet 153 can be discharged out of the frame 110. A plurality of insertion grooves 155 may be formed by being recessed into the chamber member 151 so as to accommodate both sides of the grids 171 therein. At one side of the chamber member 151, namely, at one end edge of the chamber member 151 may be disposed the other side of the first arc runner 142 having one end connected to the fixed contact 120. The second arc runner 142 may be disposed at the other side edge of the chamber member 151.

[0034] An exhaust cover 161 for covering the outlet 153 may be fixed to the upper side of the chamber member 151 by a plurality of screws 167. The exhaust cover 161, which is implemented as an insulating member, may have a rectangular plate shape. A plurality of screw holes 165, through which the screws 167 are respectively inserted, may be formed at both short edge areas of the exhaust cover 161. A plurality of communication holes 163 connected to the outside may be formed in a central area of the exhaust cover 161 so as to decrease temperature and pressure which have been increased by arcs occurred when contacts are separated from each other.

[0035] The cloth filter member 180 may be installed between the grids 171 and the exhaust cover 161 such that fragments, which are generated when the grids are melted by arcs, can be prevented from being scattered to the outside through the communication holes 163 of the exhaust cover 161. The cloth filter member 180 may be composed of a pair of first and second filters 181 and 182, which are disposed to be spaced apart from each other along a direction in which gas is discharged.

[0036] In the meantime, the first filter 181, as shown in Fig. 4, may be disposed in the chamber member 151 and have an approximately rectangular plate shape to thusly block (shield) upper areas of the grids 171. The

first filter 181 may be woven by two first wires 185 implemented as a metallic member and arrayed in parallel to each other, and two second wires 186 implemented as a metallic member and arrayed in parallel to each other, the first and second wires 185 and 186 being arrayed to be orthogonal to each other. The two first wires 185 and the two second wires 186, as shown in Fig. 5, may be woven to be curved such that they can alternately be arranged up and down with each other. Here, one first wire 185 and one second wire 186 may be provided such that each wire 185 and 186 may be arrayed up and down with each other in an alternate manner.

[0037] The second filter 182 may be woven by the same method as that adapted for the first filter 181. Here, the second filter 182 may be configured by using wires having a diameter shorter than that of the wires of the first filter 181 such that air gaps of the second filter 182 can be smaller in size than those of the first filter 181. Also, the first filter 181 and the second filter 182 may be woven by using fiber threads, such as synthetic resin.

[0038] A porous plate 193 may be disposed between the first filter 181 and the second filter 182. The porous plate 193, which is implemented as a metallic member, may have a rectangular plate shape, and have a plurality of through holes 193 formed through a planar surface thereof. Accordingly, it may be available to avoid a deformation of the first filter 181, and also to improve cooling effect and exhaust function for arcs and gases which are segmented (dispersed, distributed, etc.) and cooled more densely by the first filter 181.

[0039] In such configuration, when the movable contact 130 is rotated by an abnormal current based on the rotational shaft 136 in a direction in which the movable contact 130 is separated from the fixed contact 120, arcs may occur between each contact point 122 and 124 of the fixed contact 120 and each contact point 132 and 134 of the movable contact 130. The occurred arcs are fast moved to the extinguishing apparatus 150 via the first arc runner 141 to be segmented and cooled by the grids 171. Here, the grids 171 are partially melted by arcs of high temperature, thereby generating fragments scattered and increasing pressure between the grids 171. The pressure-increased gas and the fragments of high temperature are moved toward the outlet 153. Here, as shown in Fig. 6, the first filter 181 and the second filter 182 allow the gas to pass therethrough but prevent the fragments from being scattered therethrough. The porous plate 193 supports the first filter 181 and the second filter 181 so as not to be deformed and also facilitate cooling of arcs which have densely been segmented by passing through the first filter 181.

[0040] Fig. 7 is a cross-sectional view showing an air circuit breaker with an arc extinguishing apparatus in accordance with another embodiment of the present invention, and Fig. 8 is an enlarged perspective view of the extinguishing apparatus of Figure 7, and Fig. 9 is an enlarged cross-sectional view showing main parts of Fig. 7. The same parts as or similar parts to the aforemen-

tioned configuration will not be described for the sake of description of drawings, and will be described with reference to the same reference numerals. As shown in Figs. 7 to 9, the air circuit breaker with the arc extinguishing apparatus may comprise a frame 110 having a receiving space 112, a fixed contact 120 disposed inside the frame 110, a movable contact 130 disposed to be in contact with or separated from the fixed contact 120, and an extinguishing apparatus 150, which may include a chamber member 151 disposed in the frame 110 and having an outlet 153 formed at one side thereof, an exhaust cover 201 disposed to cover the outlet 153 of the chamber member 151, a plurality of grids 171 disposed inside the chamber member 151 to be spaced apart from one another, and a cloth filter member 180 made of fabric and disposed between the exhaust cover 201 and the grids 171 to prevent scattering of fragments which are generated when the grids 171 are melted by arcs.

[0041] The chamber member 151, which is implemented as an insulating member, may have a receiving space therein. The chamber member 151 may have an approximately rectangular parallelepiped having the outlet 153 formed at an upper end thereof. A plurality of insertion grooves 155 may be formed in both long edges in the chamber member 151. Both sides of each grid 171 may be inserted into each insertion groove 155.

[0042] The cloth filter member 180 which is woven by using metallic wires may be disposed between the outlet 153 of the chamber member 151 and the grids 171 so as to prevent scattering of fragments which are generated when the grids 171 are melted by arcs occurred. Here, the cloth filter member 180 may be composed of one of the first filter 181 and the second filter 182 described above, in relation to Figs. 2 to 6.

[0043] On the other hand, the exhaust cover 201 for covering the outlet 153 may be coupled to the outlet 153 of the chamber member 151 by a plurality of screws 207. The exhaust cover 201, which is implemented as an insulating member, may have a rectangular planer shape. The exhaust cover 201 may include a plurality of screw holes 205 and a plurality of through holes 203 which are formed through the planar surface thereof. Here, the through hole 203, the size of which is small and all the same, may be formed in the whole area of the exhaust cover 201 at a constant interval. Accordingly, the cloth filter member 180 may be prevented from being deformed and also internal gas may be allowed to be smoothly discharged through the through holes 203.

[0044] A porous plate 211 which is implemented as an insulating member may be disposed between the cloth filter member 180 and the grids 171. The porous plate 211 may have a plurality of through holes 213 formed through a planar surface thereof. Through holes 213 may be formed to correspond to an interval between the grids 171. Accordingly, fragments which are generated due to arcs may be prevented from being scattered toward the outlet 153, and also the arcs may be bypassed. Here, the porous plate 211 may be configured in plurality. Any

one of the plurality of porous plates 211 may be a porous plate 191 implemented as a metallic member described above, in relation to Figs. 2 to 6.

[0045] In such configuration, when the movable contact 130 is rotated by an abnormal current based on a rotational shaft 136 in a direction in which the movable contact 120 is separated from the fixed contact 120, arcs may occur between contact points of the fixed contact 120 and contact points of the movable contact 130. The occurred arcs are quickly moved to the extinguishing apparatus 200 via the first arc runner 141, thus to be segmented and cooled by the grids 171. Here, the grids 171 may partially be melted by the arcs of high temperature, thereby generating fragments scattered. The porous plate 211, as shown in Fig. 9, can prevent the fragments from being scattered therethrough and also induce arcs to be bypassed for movement. The cloth filter member 180 may allow gas to pass therethrough and also prevent the scattering of the fragments which passed through the porous plate 211. Here, the exhaust cover 201 may allow gases to be appropriately dispersed to smoothly pass through it, and also support the cloth filter member so as to prevent the deformation of the cloth filter member 180.

[0046] As described above, in the present invention, the cloth filter member formed of fabric is disposed at the side of the downstream of the grids, thereby effectively preventing scattering of the fragments which are generated by arcs.

[0047] In the present invention, the fabrication cost can be decreased by using the cloth filter member made of fabric.

[0048] Also, in the present invention, the exhaust cover may be disposed to cover the outlet of the chamber member and the cloth filter member may be disposed between the exhaust cover and the grids, so as to effectively prevent fragments generated due to arcs from being scattered to the outside.

[0049] In addition, in the present invention, the porous plate implemented as a metallic member may be disposed at one side of the cloth filter member, to thusly effectively cool and disperse arcs, and to more effectively prevent the fragments generated due to arcs from being discharged to the outside.

[0050] Furthermore, in the present invention, the porous plate implemented as an insulating member may be disposed at one side of the cloth filter member, to thusly effectively control the scattering of arcs, thereby effectively preventing fragments from being scattered to the outside.

[0051] The foregoing embodiments and advantages are merely exemplary and are not to be construed as limiting the present disclosure. This description is intended to be illustrative, and not to limit the scope of the claims. Many alternatives, modifications, and variations will be apparent to those skilled in the art. The features, structures, methods, and other characteristics of the exemplary embodiments described herein may be combined in various ways to obtain additional and/or alter-

native exemplary embodiments.

[0052] As the present features may be embodied in several forms without departing from the characteristics thereof, it should also be understood that the above-described embodiments are not limited by any of the details of the foregoing description, unless otherwise specified, but rather should be construed broadly within its scope as defined in the appended claims, and therefore all changes and modifications that fall within the metes and bounds of the claims, or equivalents of such metes and bounds are therefore intended to be embraced by the appended claims.

Claims

1. An air circuit breaker with an extinguishing apparatus comprising:

a frame having a receiving space therein;
 a fixed contact disposed inside the frame;
 a movable contact disposed to be in contact with or separated from the fixed contact; and
 an extinguishing apparatus which includes a chamber member disposed in the frame and having an outlet formed at one side thereof, a plurality of grids disposed in the chamber member to be spaced apart from one another, and a cloth filter member formed of fabric and disposed between the outlet and the grids to prevent scattering of fragments which are generated by arcs.

2. The air circuit breaker of claim 1, wherein the extinguishing apparatus further comprises an arc runner having one side connected to the fixed contact to induce arcs to the extinguishing apparatus when the movable contact is separated from the fixed contact.

3. The air circuit breaker of claim 2, wherein the cloth filter member is woven by arraying two wires up and down in an alternate manner with each other.

4. The air circuit breaker of claim 3, wherein the extinguishing apparatus further comprises a porous plate disposed at one side of the cloth filter member in a direction in which gas is discharged.

5. The air circuit breaker of claim 4, wherein the porous plate is implemented as a metallic member.

6. The air circuit breaker of claim 4, wherein the porous plate is implemented as an insulating member.

7. The air circuit breaker of claim 3, wherein the extinguishing apparatus further comprises an exhaust cover having a plurality of through holes formed through a planar surface thereof and coupled to the

outlet.

8. The air circuit breaker of claim 2, wherein the cloth filter member comprises a first filter and a second filter each implemented as a metallic cloth filter woven by arraying two wires to be orthogonal to each other, the first and second filter being disposed to be spaced apart from each other in a direction in which gas is discharged.

9. The air circuit breaker of claim 8, wherein the second filter has air gaps smaller than those of the first filter.

10. The air circuit breaker of claim 8, wherein the extinguishing apparatus further comprises a porous plate disposed at one side either of the first filter of the second filter.

11. The air circuit breaker of claim 10, wherein the porous plate is implemented as a metallic member.

12. The air circuit breaker of claim 10, wherein the porous plate is implemented as an insulating member.

FIG. 1
RELATED ART

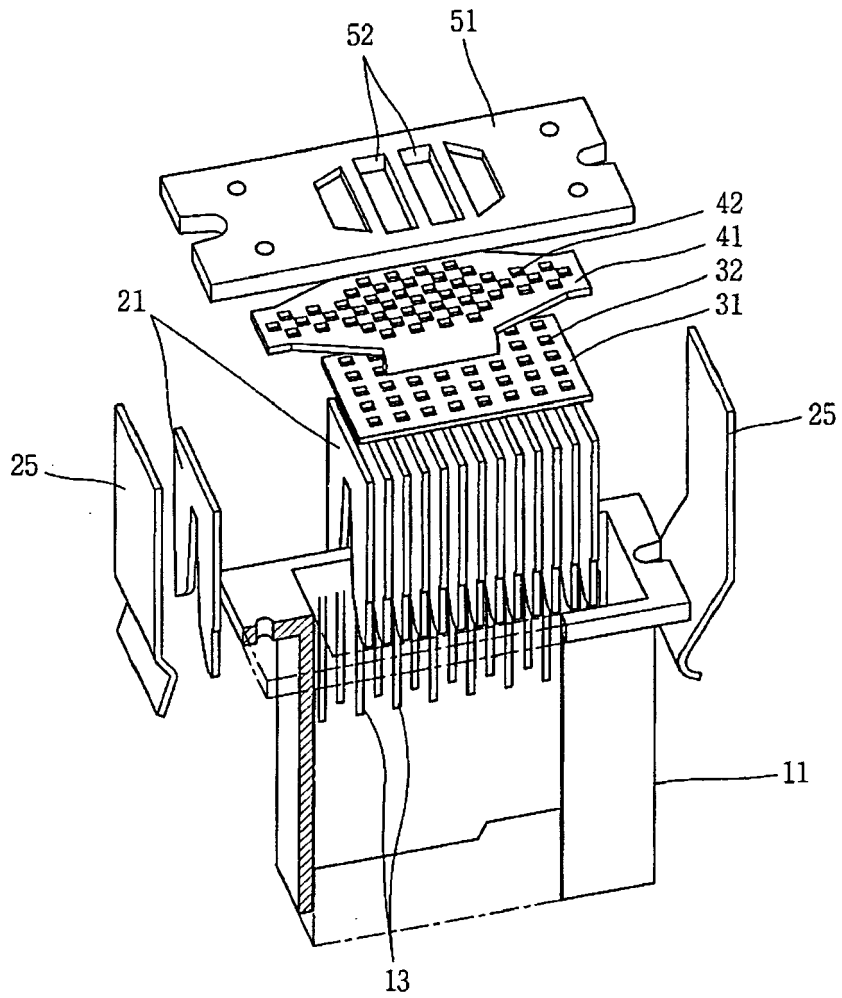

FIG. 2

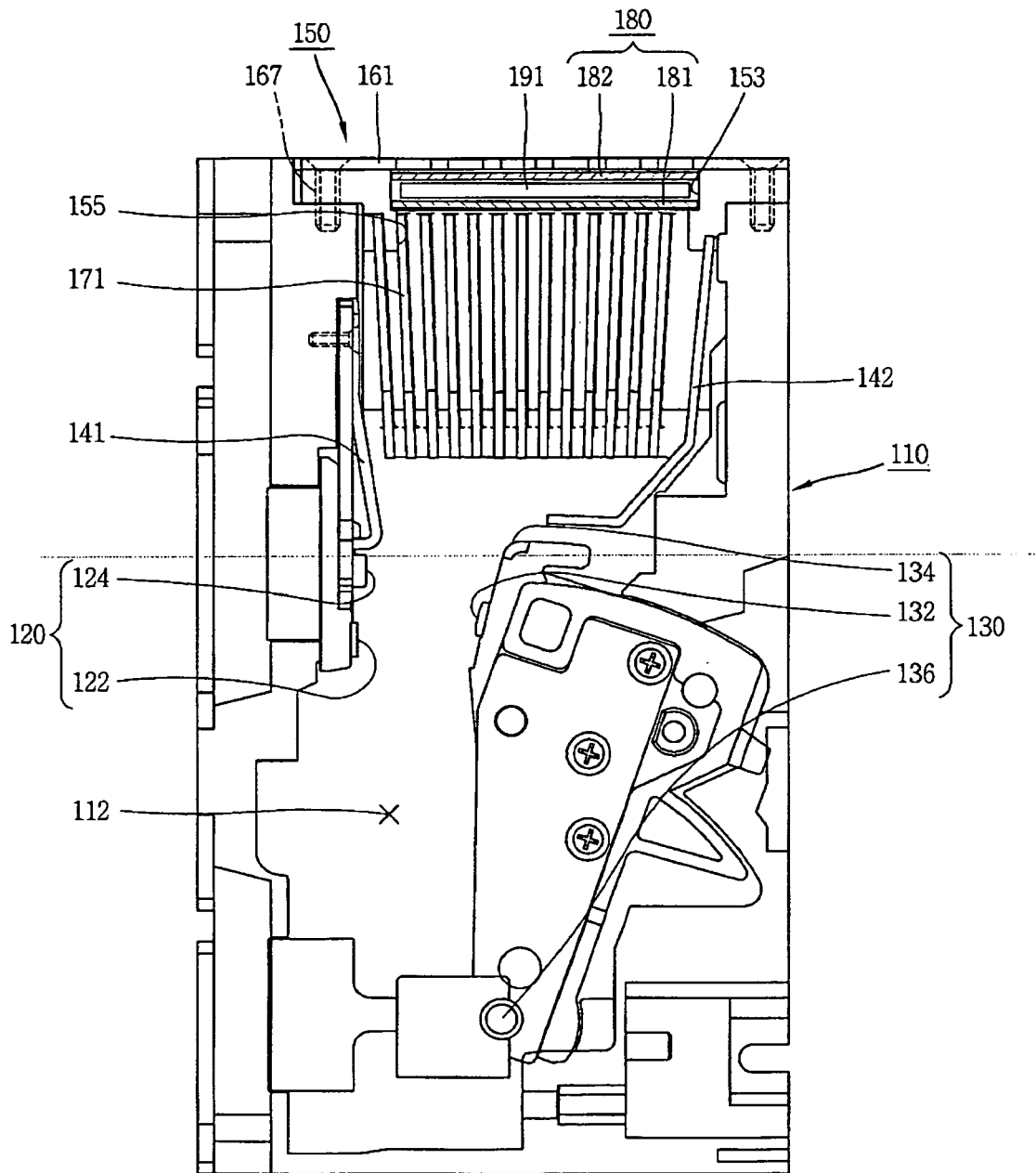

FIG. 3

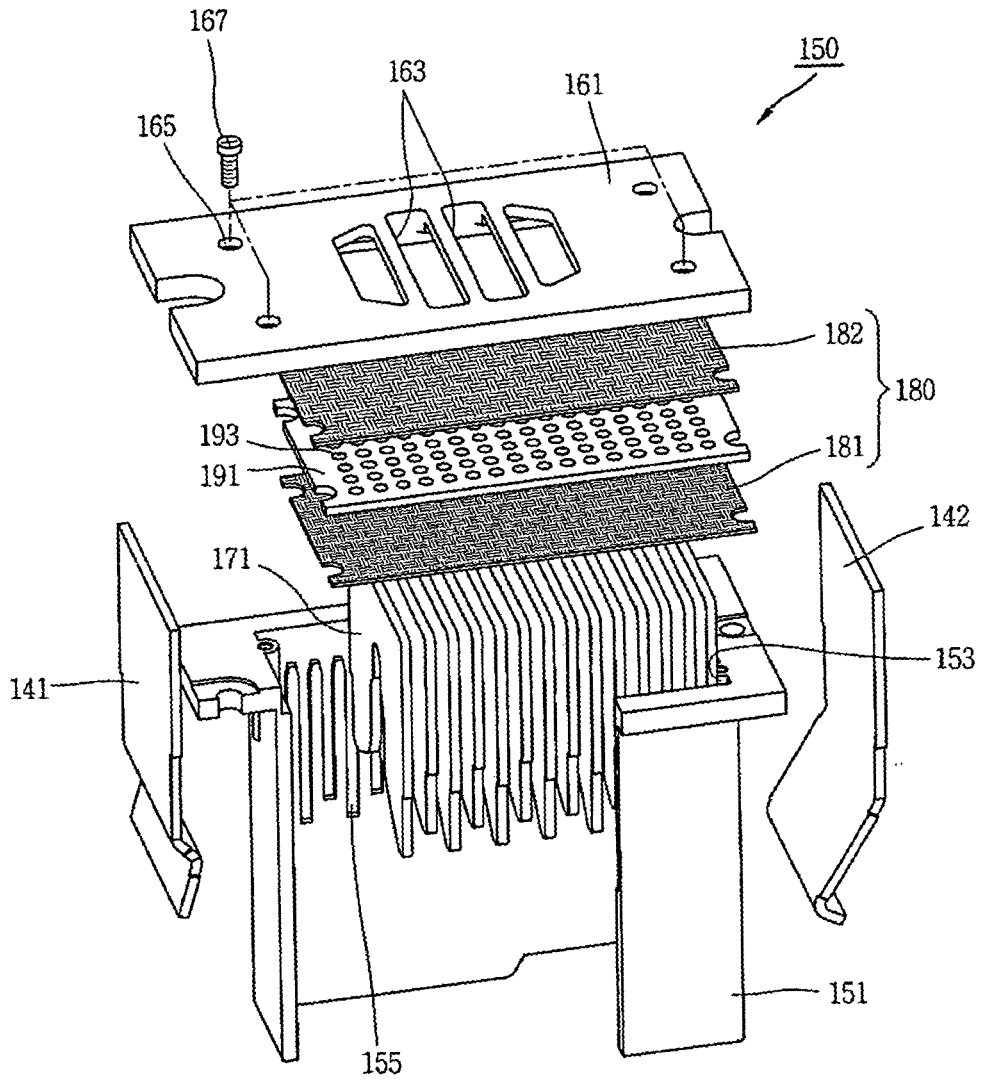

FIG. 4

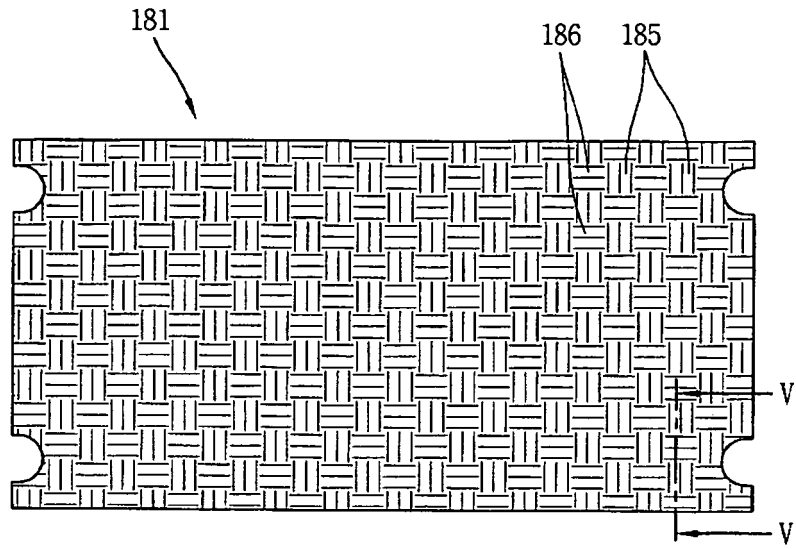

FIG. 5

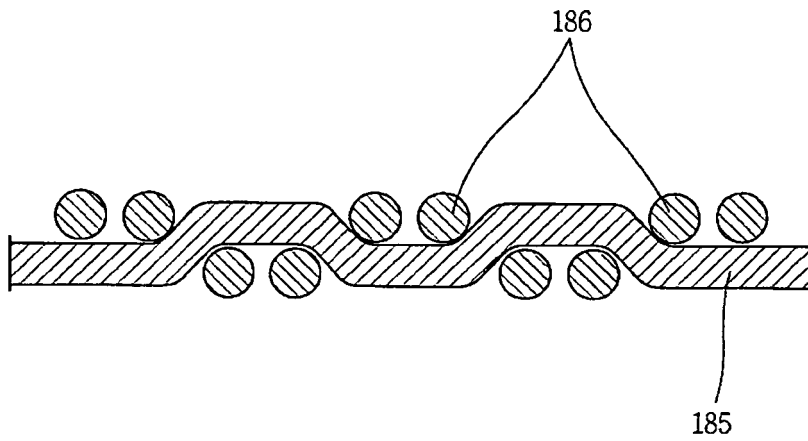

FIG. 6

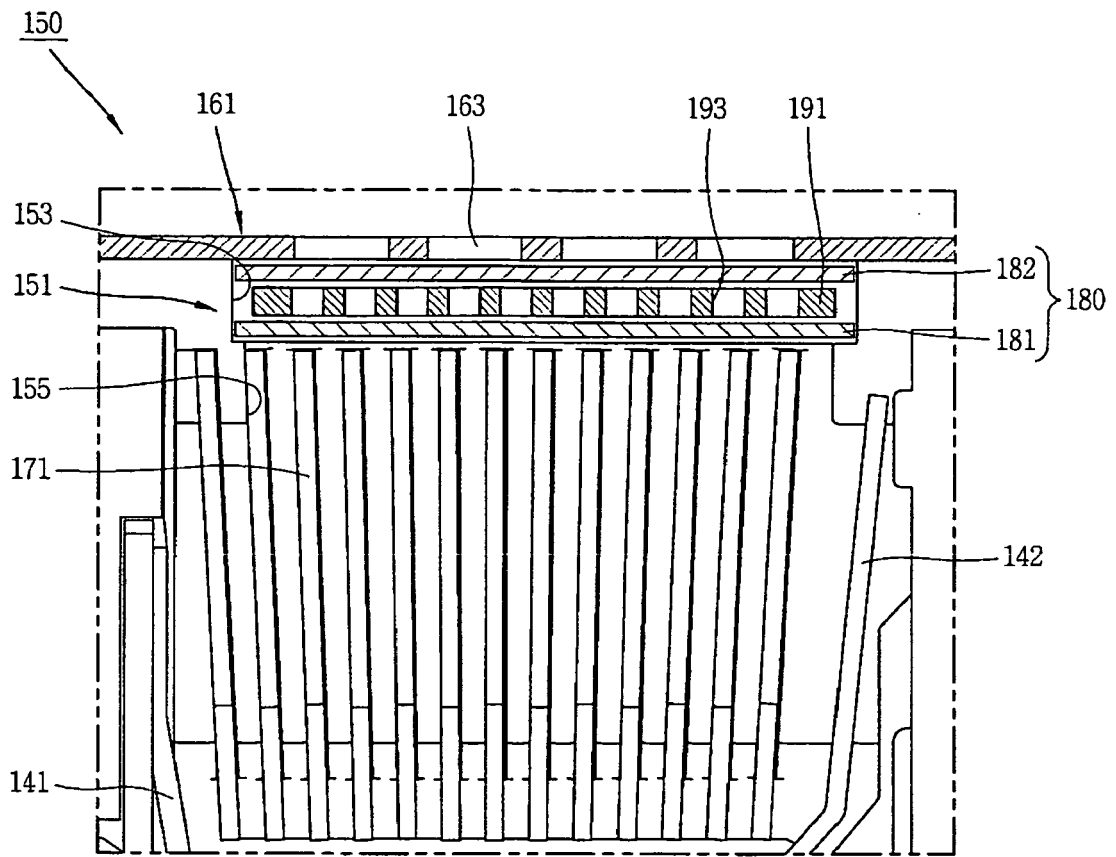

FIG. 7

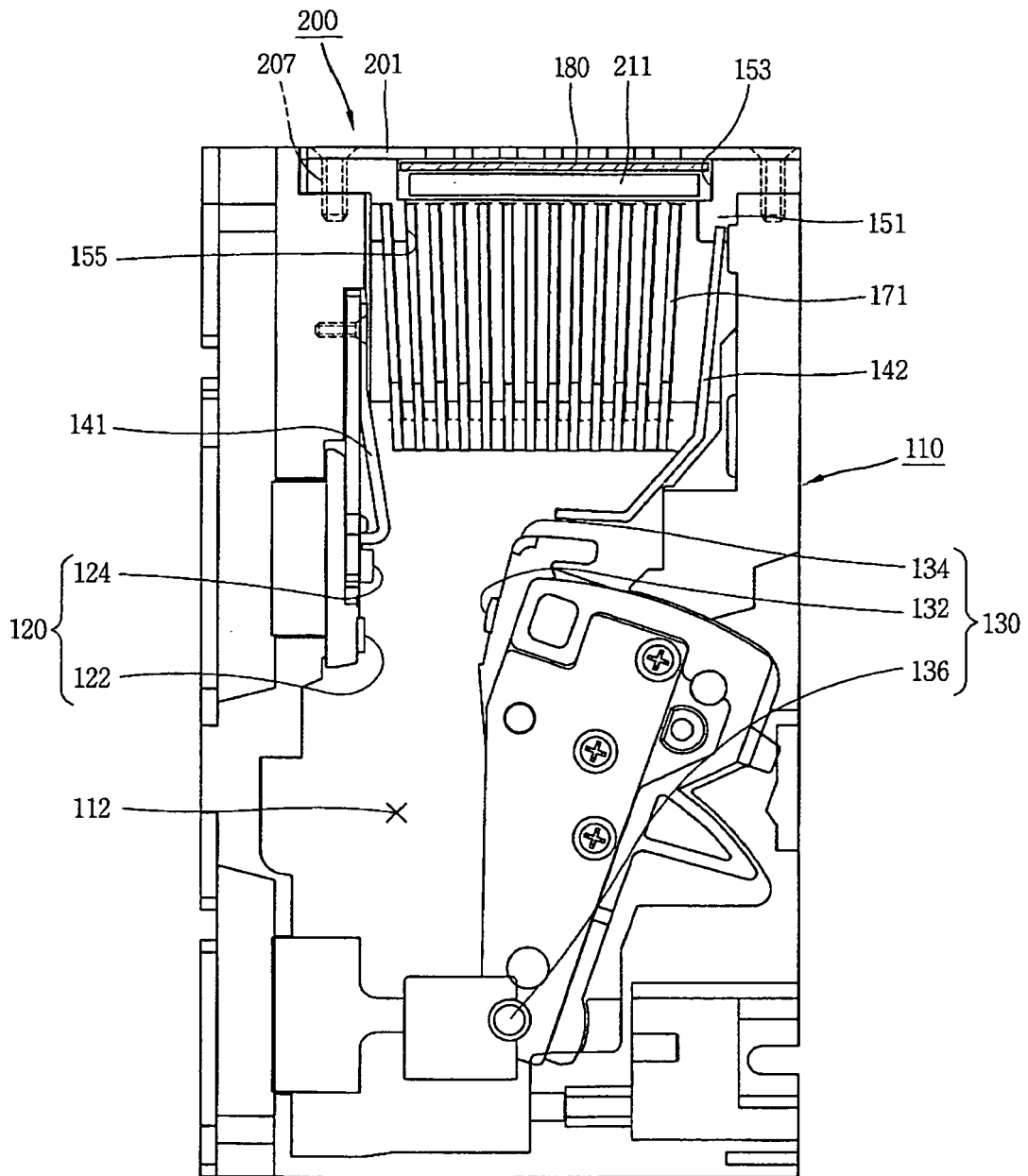

FIG. 8

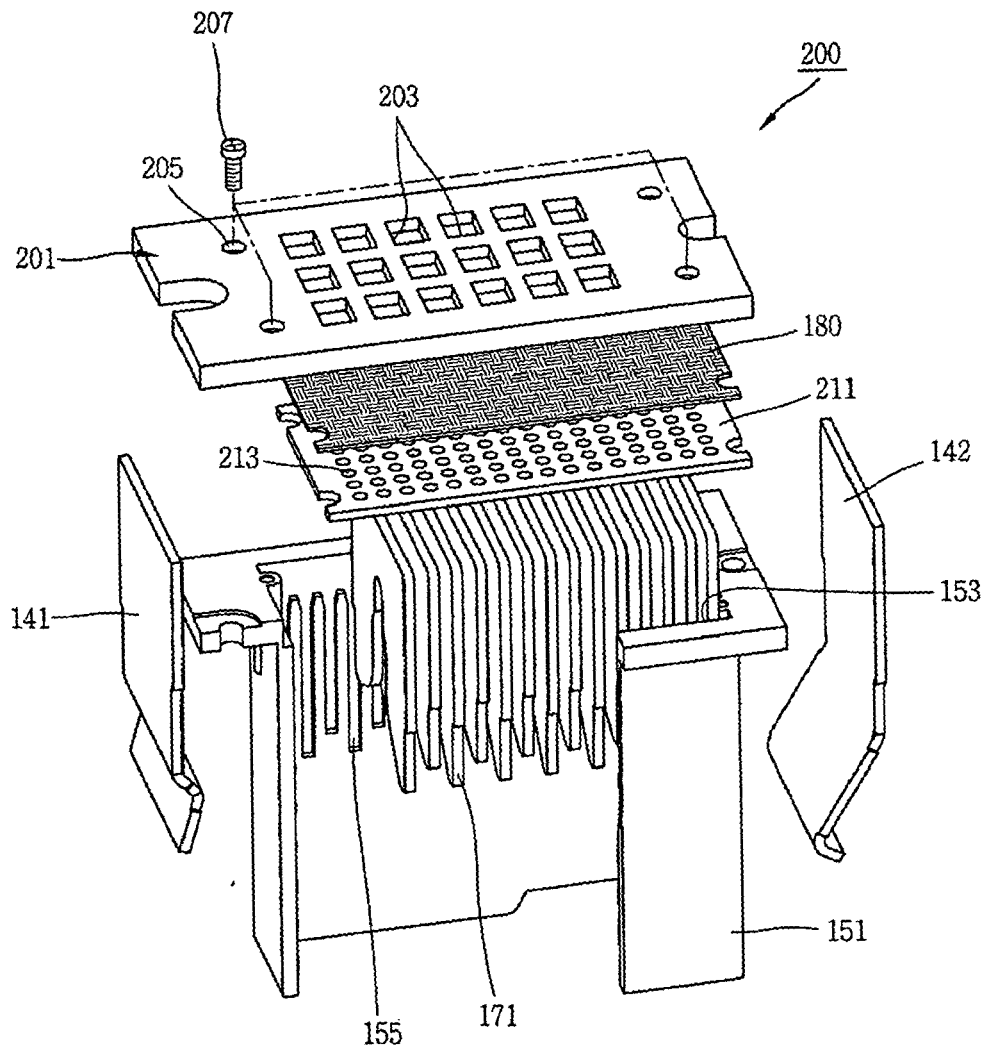

FIG. 9

