



(51) International Patent Classification:

G02F 1/167 (2006.01) G02F 1/1675 (2019.01)  
G02F 1/1676 (2019.01)

(21) International Application Number:

PCT/US2021/050237

(22) International Filing Date:

14 September 2021 (14.09.2021)

(25) Filing Language:

English

(26) Publication Language:

English

(30) Priority Data:

63/078,829 15 September 2020 (15.09.2020) US  
63/191,075 20 May 2021 (20.05.2021) US

(71) Applicant: **E INK CORPORATION** [US/US]; Attn: IP Department, 1000 Technology Park Drive, Billerica, Massachusetts 01821-4165 (US).

(72) Inventors: **TELFER, Stephen J.**; c/o E Ink Corporation, 1000 Technology Park Drive, Billerica, Massachusetts 01821-4165 (US). **BEN-DOV, Yuval**; c/o E Ink Corporation, 1000 Technology Park Drive, Billerica, Massachu-

setts 01821-4165 (US). **SIM, Teck Ping**; c/o E Ink Corporation, 1000 Technology Park Drive, Billerica, Massachusetts 01821-4165 (US). **TSAI, Sherry Hsin-Yi**; c/o E Ink Corporation, 1000 Technology Park Drive, Billerica, Massachusetts 01821-4165 (US).

(74) Agent: **BEAN, Brian D.**; c/o E Ink Corporation, 1000 Technology Park Drive, Billerica, Massachusetts 01821-4165 (US).

(81) Designated States (unless otherwise indicated, for every kind of national protection available): AE, AG, AL, AM, AO, AT, AU, AZ, BA, BB, BG, BH, BN, BR, BW, BY, BZ, CA, CH, CL, CN, CO, CR, CU, CZ, DE, DJ, DK, DM, DO, DZ, EC, EE, EG, ES, FI, GB, GD, GE, GH, GM, GT, HN, HR, HU, ID, IL, IN, IR, IS, IT, JO, JP, KE, KG, KH, KN, KP, KR, KW, KZ, LA, LC, LK, LR, LS, LU, LY, MA, MD, ME, MG, MK, MN, MW, MX, MY, MZ, NA, NG, NI, NO, NZ, OM, PA, PE, PG, PH, PL, PT, QA, RO, RS, RU, RW, SA, SC, SD, SE, SG, SK, SL, ST, SV, SY, TH, TJ, TM, TN, TR, TT, TZ, UA, UG, US, UZ, VC, VN, WS, ZA, ZM, ZW.

(84) Designated States (unless otherwise indicated, for every kind of regional protection available): ARIPO (BW, GH,

(54) Title: FOUR PARTICLE ELECTROPHORETIC MEDIUM PROVIDING FAST, HIGH-CONTRAST OPTICAL STATE SWITCHING



WO 2022/060715 A1

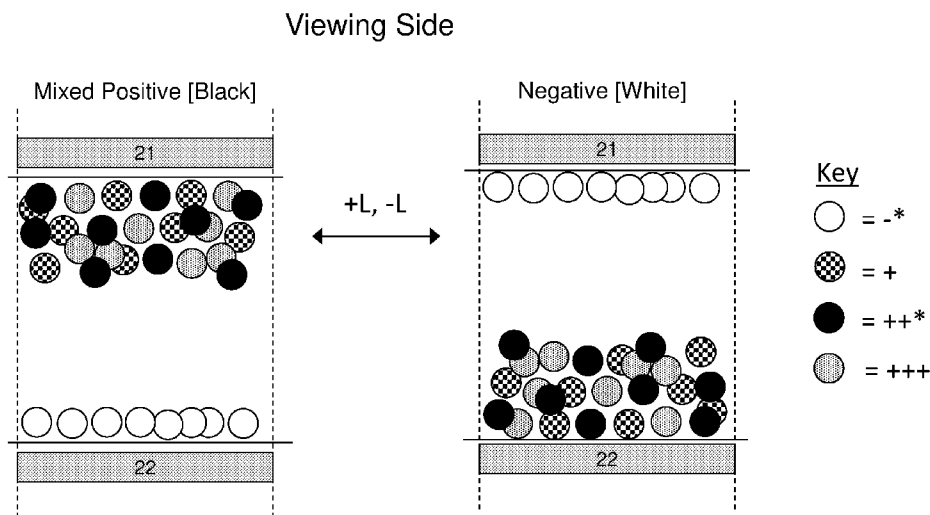

FIG. 2B

(57) Abstract: Improved electrophoretic media including a first particle of a first polarity and three particles of the opposite polarity, wherein the first particle and optionally one of the particles of the opposite polarity undergo a diminution of electrophoretic mobility with increased electric field. Such electrophoretic media enable full-color displays with very fast updates between white and black pixels.

GM, KE, LR, LS, MW, MZ, NA, RW, SD, SL, ST, SZ, TZ, UG, ZM, ZW), Eurasian (AM, AZ, BY, KG, KZ, RU, TJ, TM), European (AL, AT, BE, BG, CH, CY, CZ, DE, DK, EE, ES, FI, FR, GB, GR, HR, HU, IE, IS, IT, LT, LU, LV, MC, MK, MT, NL, NO, PL, PT, RO, RS, SE, SI, SK, SM, TR), OAPI (BF, BJ, CF, CG, CI, CM, GA, GN, GQ, GW, KM, ML, MR, NE, SN, TD, TG).

**Declarations under Rule 4.17:**

- *as to applicant's entitlement to apply for and be granted a patent (Rule 4.17(ii))*
- *as to the applicant's entitlement to claim the priority of the earlier application (Rule 4.17(iii))*

**Published:**

- *with international search report (Art. 21(3))*

# FOUR PARTICLE ELECTROPHORETIC MEDIUM PROVIDING FAST, HIGH-CONTRAST OPTICAL STATE SWITCHING

## RELATED APPLICATIONS

**[Para 1]** This application claims priority to U.S. Provisional Patent Application No. 63/078,829, filed September 15, 2020 and U.S. Provisional Patent Application No. 63/191,075, filed May 20, 2021. All patents and publications disclosed herein are incorporated by reference in their entireties.

## BACKGROUND

**[Para 2]** An electrophoretic display (EPD) changes color by modifying the position of a charged colored particle with respect to a light-transmissive viewing surface. Such electrophoretic displays are typically referred to as “electronic paper” or “ePaper” because the resulting display has high contrast and is sunlight-readable, much like ink on paper. Electrophoretic displays have enjoyed widespread adoption in eReaders, such as the AMAZON KINDLE® because the electrophoretic displays provide a book-like reading experience, use little power, and allow a user to carry a library of hundreds of books in a lightweight handheld device.

**[Para 3]** For many years, electrophoretic displays included only two types of charged color particles, black and white. (To be sure, “color” as used herein includes black and white.) The white particles are often of the light scattering type, and comprise, e.g., titanium dioxide, while the black particles are absorptive across the visible spectrum, and may comprise carbon black, or an absorptive metal oxide, such as copper chromite. In the simplest sense, a black and white electrophoretic display only requires a light-transmissive electrode at the viewing surface, a back electrode, and an electrophoretic medium including oppositely charged white and black particles. When a voltage of one polarity is provided, the white particles move to the viewing surface, and when a voltage of the opposite polarity is provided the black particles move to the viewing surface. If the back electrode includes controllable regions (pixels) – either segmented electrodes or an active matrix of pixel electrodes controlled by transistors – a pattern can be made to appear electronically at the viewing surface. The pattern can be, for example, the text to a book.

**[Para 4]** More recently, a variety of color options have become commercially available for electrophoretic displays, including three-color displays (black, white, red; black white, yellow),

and four color displays (black, white, red, yellow). Similar to the operation of black and white electrophoretic displays, electrophoretic displays with three or four reflective particles operate similar to the simple black and white displays because the desired color particle is driven to the viewing surface. The driving schemes are far more complicated than only black and white, but in the end, the optical function of the particles is the same.

**[Para 5]** Advanced Color electronic Paper (ACeP™) also included four particles, but the cyan, yellow, and magenta particles are subtractive rather than reflective, thereby allowing thousands of colors to be produced at each pixel. The color process is functionally equivalent to the printing methods that have long been used in offset printing and ink-jet printers. A given color is produced by using the correct ratio of cyan, yellow, and magenta on a bright white paper background. In the instance of ACeP, the relative positions of the cyan, yellow, magenta and white particles with respect to the viewing surface will determine the color at each pixel. While this type of electrophoretic display allows for thousands of colors at each pixel, it is critical to carefully control the position of each of the (50 to 500 nanometer-sized) pigments within a working space of about 10 to 20 micrometers in thickness. Obviously, variations in the position of the particles will result in incorrect colors being displayed at a given pixel. Accordingly, exquisite voltage control is required for such a system. More details of this system are available in the following U.S. Patents, all of which are incorporated by reference in their entireties: U.S. Patent Nos. 9,361,836, 9,921,451, 10,276,109, 10,353,266, 10,467,984, and 10,593,272.

**[Para 6]** The term gray state is used herein in its conventional meaning in the imaging art to refer to a state intermediate two extreme optical states of a pixel, and does not necessarily imply a black-white transition between these two extreme states. For example, several of the E Ink patents and published applications referred to below describe electrophoretic displays in which the extreme states are white and deep blue, so that an intermediate gray state would actually be pale blue. Indeed, as already mentioned, the change in optical state may not be a color change at all. The terms black and white may be used hereinafter to refer to the two extreme optical states of a display, and should be understood as normally including extreme optical states which are not strictly black and white, for example the aforementioned white and dark blue states.

**[Para 7]** The terms bistable and bistability are used herein in their conventional meaning in the art to refer to displays comprising display elements having first and second display states differing in at least one optical property, and such that after any given element has been driven, by means of an addressing pulse of finite duration, to assume either its first or second display

state, after the addressing pulse has terminated, that state will persist for at least several times, for example at least four times, the minimum duration of the addressing pulse required to change the state of the display element. It is shown in U.S. Patent No. 7,170,670 that some particle-based electrophoretic displays capable of gray scale are stable not only in their extreme black and white states but also in their intermediate gray states, and the same is true of some other types of electro-optic displays. This type of display is properly called multi-stable rather than bistable, although for convenience the term bistable may be used herein to cover both bistable and multi-stable displays.

**[Para 8]** The term impulse, when used to refer to driving an electrophoretic display, is used herein to refer to the integral of the applied voltage with respect to time during the period in which the display is driven.

**[Para 9]** A particle that absorbs, scatters, or reflects light, either in a broad band or at selected wavelengths, is referred to herein as a colored or pigment particle. Various materials other than pigments (in the strict sense of that term as meaning insoluble colored materials) that absorb or reflect light, such as dyes or photonic crystals, etc., may also be used in the electrophoretic media and displays of the present invention.

**[Para 10]** Particle-based electrophoretic displays have been the subject of intense research and development for a number of years. In such displays, a plurality of charged particles (sometimes referred to as pigment particles) move through a fluid under the influence of an electric field. Electrophoretic displays can have attributes of good brightness and contrast, wide viewing angles, state bistability, and low power consumption when compared with liquid crystal displays. Nevertheless, problems with the long-term image quality of these displays have prevented their widespread usage. For example, particles that make up electrophoretic displays tend to settle, resulting in inadequate service-life for these displays.

**[Para 11]** As noted above, electrophoretic media require the presence of a fluid. In most prior art electrophoretic media, this fluid is a liquid, but electrophoretic media can be produced using gaseous fluids; see, for example, Kitamura, T., et al., Electrical toner movement for electronic paper-like display, IDW Japan, 2001, Paper HCS1-1, and Yamaguchi, Y., et al., Toner display using insulative particles charged triboelectrically, IDW Japan, 2001, Paper AMD4-4). See also U.S. Patents Nos. 7,321,459 and 7,236,291. Such gas-based electrophoretic media appear to be susceptible to the same types of problems due to particle settling as liquid-based electrophoretic media, when the media are used in an orientation which permits such settling, for example in a sign where the medium is disposed in a vertical plane. Indeed, particle settling

appears to be a more serious problem in gas-based electrophoretic media than in liquid-based ones, since the lower viscosity of gaseous suspending fluids as compared with liquid ones allows more rapid settling of the electrophoretic particles.

**[Para 12]** Numerous patents and applications assigned to or in the names of the Massachusetts Institute of Technology (MIT) and E Ink Corporation describe various technologies used in encapsulated electrophoretic and other electro-optic media. Such encapsulated media comprise numerous small capsules, each of which itself comprises an internal phase containing electrophoretically-mobile particles in a fluid medium, and a capsule wall surrounding the internal phase. Typically, the capsules are themselves held within a polymeric binder to form a coherent layer positioned between two electrodes. The technologies described in these patents and applications include:

- (a) Electrophoretic particles, fluids and fluid additives; see for example U.S. Patents Nos. 7,002,728 and 7,679,814;
- (b) Capsules, binders and encapsulation processes; see for example U.S. Patents Nos. 6,922,276 and 7,411,719;
- (c) Microcell structures, wall materials, and methods of forming microcells; see for example United States Patents Nos. 7,072,095 and 9,279,906;
- (d) Methods for filling and sealing microcells; see for example United States Patents Nos. 7,144,942 and 7,715,088;
- (e) Films and sub-assemblies containing electro-optic materials; see for example U.S. Patents Nos. 6,982,178 and 7,839,564;
- (f) Backplanes, adhesive layers and other auxiliary layers and methods used in displays; see for example U.S. Patents Nos. 7,116,318 and 7,535,624;
- (g) Color formation color adjustment; see for example U.S. Patents Nos. 6,017,584; 6,545,797; 6,664,944; 6,788,452; 6,864,875; 6,914,714; 6,972,893; 7,038,656; 7,038,670; 7,046,228; 7,052,571; 7,075,502\*\*\*; 7,167,155; 7,385,751; 7,492,505; 7,667,684; 7,684,108; 7,791,789; 7,800,813; 7,821,702; 7,839,564\*\*\*; 7,910,175; 7,952,790; 7,956,841; 7,982,941; 8,040,594; 8,054,526; 8,098,418; 8,159,636; 8,213,076; 8,363,299; 8,422,116; 8,441,714; 8,441,716; 8,466,852; 8,503,063; 8,576,470; 8,576,475; 8,593,721; 8,605,354; 8,649,084; 8,670,174; 8,704,756; 8,717,664; 8,786,935; 8,797,634;

8,810,899; 8,830,559; 8,873,129; 8,902,153; 8,902,491; 8,917,439; 8,964,282; 9,013,783; 9,116,412; 9,146,439; 9,164,207; 9,170,467; 9,170,468; 9,182,646; 9,195,111; 9,199,441; 9,268,191; 9,285,649; 9,293,511; 9,341,916; 9,360,733; 9,361,836; 9,383,623; and 9,423,666; and U.S. Patent Applications Publication Nos. 2008/0043318; 2008/0048970; 2009/0225398; 2010/0156780; 2011/0043543; 2012/0326957; 2013/0242378; 2013/0278995; 2014/0055840; 2014/0078576; 2014/0340430; 2014/0340736; 2014/0362213; 2015/0103394; 2015/0118390; 2015/0124345; 2015/0198858; 2015/0234250; 2015/0268531; 2015/0301246; 2016/0011484; 2016/0026062; 2016/0048054; 2016/0116816; 2016/0116818; and 2016/0140909;

(h) Methods for driving displays; see for example U.S. Patents Nos. 5,930,026; 6,445,489; 6,504,524; 6,512,354; 6,531,997; 6,753,999; 6,825,970; 6,900,851; 6,995,550; 7,012,600; 7,023,420; 7,034,783; 7,061,166; 7,061,662; 7,116,466; 7,119,772; 7,177,066; 7,193,625; 7,202,847; 7,242,514; 7,259,744; 7,304,787; 7,312,794; 7,327,511; 7,408,699; 7,453,445; 7,492,339; 7,528,822; 7,545,358; 7,583,251; 7,602,374; 7,612,760; 7,679,599; 7,679,813; 7,683,606; 7,688,297; 7,729,039; 7,733,311; 7,733,335; 7,787,169; 7,859,742; 7,952,557; 7,956,841; 7,982,479; 7,999,787; 8,077,141; 8,125,501; 8,139,050; 8,174,490; 8,243,013; 8,274,472; 8,289,250; 8,300,006; 8,305,341; 8,314,784; 8,373,649; 8,384,658; 8,456,414; 8,462,102; 8,514,168; 8,537,105; 8,558,783; 8,558,785; 8,558,786; 8,558,855; 8,576,164; 8,576,259; 8,593,396; 8,605,032; 8,643,595; 8,665,206; 8,681,191; 8,730,153; 8,810,525; 8,928,562; 8,928,641; 8,976,444; 9,013,394; 9,019,197; 9,019,198; 9,019,318; 9,082,352; 9,171,508; 9,218,773; 9,224,338; 9,224,342; 9,224,344; 9,230,492; 9,251,736; 9,262,973; 9,269,311; 9,299,294; 9,373,289; 9,390,066; 9,390,661; and 9,412,314; and U.S. Patent Applications Publication Nos. 2003/0102858; 2004/0246562; 2005/0253777; 2007/0091418; 2007/0103427; 2007/0176912; 2008/0024429; 2008/0024482; 2008/0136774; 2008/0291129; 2008/0303780; 2009/0174651; 2009/0195568; 2009/0322721; 2010/0194733; 2010/0194789; 2010/0220121; 2010/0265561; 2010/0283804; 2011/0063314; 2011/0175875; 2011/0193840; 2011/0193841; 2011/0199671; 2011/0221740; 2012/0001957; 2012/0098740; 2013/0063333; 2013/0194250; 2013/0249782; 2013/0321278; 2014/0009817; 2014/0085355; 2014/0204012; 2014/0218277; 2014/0240210; 2014/0240373; 2014/0253425;

2014/0292830; 2014/0293398; 2014/0333685; 2014/0340734; 2015/0070744; 2015/0097877; 2015/0109283; 2015/0213749; 2015/0213765; 2015/0221257; 2015/0262255; 2015/0262551; 2016/0071465; 2016/0078820; 2016/0093253; 2016/0140910; and 2016/0180777 (these patents and applications may hereinafter be referred to as the MEDEOD (MEthods for Driving Electro-optic Displays) applications);

(i) Applications of displays; see for example U.S. Patents Nos. 7,312,784 and 8,009,348; and

(j) Non-electrophoretic displays, as described in U.S. Patents Nos. 6,241,921; and U.S. Patent Applications Publication Nos. 2015/0277160; and U.S. Patent Application Publications Nos. 2015/0005720 and 2016/0012710.

**[Para 13]** Many of the aforementioned patents and applications recognize that the walls surrounding the discrete microcapsules in an encapsulated electrophoretic medium could be replaced by a continuous phase, thus producing a so-called polymer-dispersed electrophoretic display, in which the electrophoretic medium comprises a plurality of discrete droplets of an electrophoretic fluid and a continuous phase of a polymeric material, and that the discrete droplets of electrophoretic fluid within such a polymer-dispersed electrophoretic display may be regarded as capsules or microcapsules even though no discrete capsule membrane is associated with each individual droplet; see for example, U.S. Patent No. 6,866,760. Accordingly, for purposes of the present application, such polymer-dispersed electrophoretic media are regarded as sub-species of encapsulated electrophoretic media.

**[Para 14]** A related type of electrophoretic display is a so-called microcell electrophoretic display. In a microcell electrophoretic display, the charged particles and the fluid are not encapsulated within microcapsules but instead are retained within a plurality of cavities formed within a carrier medium, typically a polymeric film. See, for example, U.S. Patents Nos. 6,672,921 and 6,788,449.

**[Para 15]** Although electrophoretic media are often opaque (since, for example, in many electrophoretic media, the particles substantially block transmission of visible light through the display) and operate in a reflective mode, many electrophoretic displays can be made to operate in a so-called shutter mode in which one display state is substantially opaque and one is light-transmissive. See, for example, U.S. Patents Nos. 5,872,552; 6,130,774; 6,144,361; 6,172,798; 6,271,823; 6,225,971; and 6,184,856. Dielectrophoretic displays, which are similar to electrophoretic displays but rely upon variations in electric field strength, can operate in a

similar mode; see U.S. Patent No. 4,418,346. Other types of electro-optic displays may also be capable of operating in shutter mode. Electro-optic media operating in shutter mode can be used in multi-layer structures for full color displays; in such structures, at least one layer adjacent the viewing surface of the display operates in shutter mode to expose or conceal a second layer more distant from the viewing surface.

**[Para 16]** An encapsulated electrophoretic display typically does not suffer from the clustering and settling failure mode of traditional electrophoretic devices and provides further advantages, such as the ability to print or coat the display on a wide variety of flexible and rigid substrates. (Use of the word printing is intended to include all forms of printing and coating, including, but without limitation: pre-metered coatings such as patch die coating, slot or extrusion coating, slide or cascade coating, curtain coating; roll coating such as knife over roll coating, forward and reverse roll coating; gravure coating; dip coating; spray coating; meniscus coating; spin coating; brush coating; air knife coating; silk screen printing processes; electrostatic printing processes; thermal printing processes; ink jet printing processes; electrophoretic deposition (See U.S. Patent No. 7,339,715); and other similar techniques.) Thus, the resulting display can be flexible. Further, because the display medium can be printed (using a variety of methods), the display itself can be made inexpensively.

**[Para 17]** As indicated above most simple prior art electrophoretic media essentially display only two colors. Such electrophoretic media either use a single type of electrophoretic particle having a first color in a colored fluid having a second, different color (in which case, the first color is displayed when the particles lie adjacent the viewing surface of the display and the second color is displayed when the particles are spaced from the viewing surface), or first and second types of electrophoretic particles having differing first and second colors in an uncolored fluid (in which case, the first color is displayed when the first type of particles lie adjacent the viewing surface of the display and the second color is displayed when the second type of particles lie adjacent the viewing surface). Typically the two colors are black and white. If a full color display is desired, a color filter array may be deposited over the viewing surface of the monochrome (black and white) display. Displays with color filter arrays rely on area sharing and color blending to create color stimuli. The available display area is shared between three or four primary colors such as red/green/blue (RGB) or red/green/blue/white (RGBW), and the filters can be arranged in one-dimensional (stripe) or two-dimensional (2x2) repeat patterns. Other choices of primary colors or more than three primaries are also known in the art. The three (in the case of RGB displays) or four (in the case of RGBW displays) sub-pixels

are chosen small enough so that at the intended viewing distance they visually blend together to a single pixel with a uniform color stimulus ('color blending'). The inherent disadvantage of area sharing is that the colorants are always present, and colors can only be modulated by switching the corresponding pixels of the underlying monochrome display to white or black (switching the corresponding primary colors on or off). For example, in an ideal RGBW display, each of the red, green, blue and white primaries occupy one fourth of the display area (one sub-pixel out of four), with the white sub-pixel being as bright as the underlying monochrome display white, and each of the colored sub-pixels being no lighter than one third of the monochrome display white. The brightness of the white color shown by the display as a whole cannot be more than one half of the brightness of the white sub-pixel (white areas of the display are produced by displaying the one white sub-pixel out of each four, plus each colored sub-pixel in its colored form being equivalent to one third of a white sub-pixel, so the three colored sub-pixels combined contribute no more than the one white sub-pixel). The brightness and saturation of colors is lowered by area-sharing with color pixels switched to black. Area sharing is especially problematic when mixing yellow because it is lighter than any other color of equal brightness, and saturated yellow is almost as bright as white. Switching the blue pixels (one fourth of the display area) to black makes the yellow too dark.

**[Para 18]** U.S. Patent Nos. 8,576,476 and 8,797,634 describe multicolor electrophoretic displays having a single back plane comprising independently addressable pixel electrodes and a common, light-transmissive front electrode. Between the back plane and the front electrode is disposed a plurality of electrophoretic layers. Displays described in these applications are capable of rendering any of the primary colors (red, green, blue, cyan, magenta, yellow, white and black) at any pixel location. However, there are disadvantages to the use of multiple electrophoretic layers located between a single set of addressing electrodes. The electric field experienced by the particles in a particular layer is lower than would be the case for a single electrophoretic layer addressed with the same voltage. In addition, optical losses in an electrophoretic layer closest to the viewing surface (for example, caused by light scattering or unwanted absorption) may affect the appearance of images formed in underlying electrophoretic layers.

**[Para 19]** Two other types of electrophoretic display systems provide a single electrophoretic medium capable of rendering any color at any pixel location. Specifically, U. S. Patent No. 9,697,778 describes a display in which a dyed solvent is combined with a white (light-scattering) particle that moves in a first direction when addressed with a low applied voltage

and in the opposite direction when addressed with a higher voltage. When the white particles and the dyed solvent are combined with two additional particles of opposite charge to the white particle, it is possible to render a full-color display. However, the color states of the '778 patent are not acceptable for applications such as a text reader. In particular, there will always be some of the dyed fluid separating the white scattering particle from the viewing surface, which leads to a tint in the white state of the display.

**[Para 20]** A second form of electrophoretic medium capable of rendering any color at any pixel location is described in U. S. Patent No. 9,921,451. In the '451 patent, the electrophoretic medium includes four particles: white, cyan, magenta and yellow, in which two of the particles are positively-charged and two negatively charged. However displays of the '451 patent also suffer from color mixing with the white state. Because one of the particles has the same charge as the white particle, some quantity of the same-charge particle moves with the white toward the viewing surface when the white state is desired. While it is possible to overcome this unwanted tinting with complex waveforms, such waveforms greatly increase the update time of the display and in some instances, result in unacceptable "flashing" between images.

## SUMMARY

**[Para 21]** Disclosed herein are improved electrophoretic display systems including four particles. Whereas the prior art describes four sets of particles with two particles of each charge polarity, the invention makes use of a single type of particle of one charge polarity (typically negatively charged) and three types of particles of the opposite charge polarity (typically positively charged). This arrangement assures a fast and clean optical state of the single particle of the first charge polarity (typically white). Additionally, when the particles of the opposite charge polarity are chosen with suitable complimentary colors, a high-quality process black can be produced, which allows for fast black on white text page turn updates.

**[Para 22]** In a first aspect the invention provides an electrophoretic medium comprising a non-polar fluid and including a first type of particle having a first optical property and a first charge polarity, a second type of particle having a second optical property, and having a second charge polarity with a first charge magnitude, the second particle having a surface coating of polymer that is covalently bound to the particle, a third type of particle having a third optical property, and having the second charge polarity with a second charge magnitude smaller than the first charge magnitude, and a fourth particle having a fourth optical property, and having the second charge polarity with a third charge magnitude larger than the first charge magnitude, wherein

the third type of particle and the fourth type of particle both include a layer of polymer complexed to the particle. In some embodiments, the electrophoretic medium is disposed between two electrodes separated by 10-50  $\mu\text{m}$ , the first type of particle has a lower electrophoretic mobility when 20V is applied between the two electrodes than when 10V is applied between the electrodes. In some embodiments, the first particle is a light-scattering particle, and the second, third, and fourth particles are light-absorbing. In some embodiments, the first particle is white, and the second, third, and fourth particles are selected from cyan, magenta, and yellow. In some embodiments, the yellow, magenta and cyan pigments exhibit diffuse reflectances at 650, 550 and 450 nm, respectively, when the respective particles are approximately isotropically distributed at 15% by volume (volume particles to volume solution) in a non-polar fluid having a refractive index less than 1.55 to make a solution, and the solution is disposed in a layer of thickness of approximately 1  $\mu\text{m}$  over a black background. In some embodiments, the first charge polarity is negative and the second charge polarity is positive. In some embodiments, the electrophoretic medium is disposed in a color electrophoretic display. The color electrophoretic display includes a light-transmissive electrode at a viewing surface, a backplane including an array of thin film transistors coupled to pixel electrodes, and a color electrophoretic medium as described above between the light-transmissive electrode and the backplane. Such a display may be incorporated into an electronic book reader, portable computer, tablet computer, cellular telephone, smart card, sign, watch, shelf label or flash drive.

**[Para 23]** In a second aspect the invention provides an electrophoretic medium comprising a non-polar fluid and including a first type of particle having a first optical property and a first charge polarity, a second type of particle having a second optical property, and having a second charge polarity with a first charge magnitude, the second particle having no surface coating of polymer, a third type of particle having a third optical property, and having the second charge polarity with a second charge magnitude smaller than the first charge magnitude, and a fourth particle having a fourth optical property, and having the second charge polarity with a third charge magnitude larger than the first charge magnitude, wherein the third type of particle and the fourth type of particle both include a layer of polymer complexed to the particle. In some embodiments, the electrophoretic medium is disposed between two electrodes separated by 10-50  $\mu\text{m}$ , the first type of particle has a lower electrophoretic mobility when 20V is applied between the two electrodes than when 10V is applied between the electrodes. In some embodiments, the first particle is a light-scattering particle, and the second, third, and fourth

particles are light-absorbing. In some embodiments, the first particle is white, and the second, third, and fourth particles are selected from cyan, magenta, and yellow. In some embodiments, the yellow, magenta and cyan pigments exhibit diffuse reflectances at 650, 550 and 450 nm, respectively, when the respective particles are approximately isotropically distributed at 15% by volume (volume particles to volume solution) in a non-polar fluid having a refractive index less than 1.55 to make a solution, and the solution is disposed in a layer of thickness of approximately 1  $\mu\text{m}$  over a black background. In some embodiments, the first charge polarity is negative and the second charge polarity is positive. In some embodiments, the electrophoretic medium is disposed in a color electrophoretic display. The color electrophoretic display includes a light-transmissive electrode at a viewing surface, a backplane including an array of thin film transistors coupled to pixel electrodes, and a color electrophoretic medium as described above between the light-transmissive electrode and the backplane. Such a display may be incorporated into an electronic book reader, portable computer, tablet computer, cellular telephone, smart card, sign, watch, shelf label or flash drive.

**[Para 24]** In a third aspect the invention provides an electrophoretic medium comprising a non-polar fluid and including a first type of particle having a first optical property and a first charge polarity, a second type of particle having a second optical property, and having a second charge polarity with a first charge magnitude, the second particle having greater than 200 mg of a charge control agent (CCA) adsorbed onto the second particle for each gram of second particle in the electrophoretic medium, a third type of particle having a third optical property, and having the second charge polarity with a second charge magnitude smaller than the first charge magnitude, and a fourth particle having a fourth optical property, and having the second charge polarity with a third charge magnitude larger than the first charge magnitude, wherein the third type of particle and the fourth type of particle each have less than 50 mg of a charge control agent (CCA) adsorbed onto the third and fourth particle for each respective gram of third and fourth particles in the electrophoretic medium. In some embodiments, the charge control agent comprises a quaternary amine head group and a fatty acid tail. In some embodiments, the electrophoretic medium is disposed between two electrodes separated by 10-50  $\mu\text{m}$ , the first type of particle has a lower electrophoretic mobility when 20V is applied between the two electrodes than when 10V is applied between the electrodes. In some embodiments, the first particle is a light-scattering particle, and the second, third, and fourth particles are light-absorbing. In some embodiments, the first particle is white, and the second, third, and fourth particles are selected from cyan, magenta, and yellow. In some embodiments,

the yellow, magenta and cyan pigments exhibit diffuse reflectances at 650, 550 and 450 nm, respectively, when the respective particles are approximately isotropically distributed at 15% by volume (volume particles to volume solution) in a non-polar fluid having a refractive index less than 1.55 to make a solution, and the solution is disposed in a layer of thickness of approximately 1  $\mu\text{m}$  over a black background. In some embodiments, the first charge polarity is negative and the second charge polarity is positive. In some embodiments, the electrophoretic medium is disposed in a color electrophoretic display. The color electrophoretic display includes a light-transmissive electrode at a viewing surface, a backplane including an array of thin film transistors coupled to pixel electrodes, and a color electrophoretic medium as described above between the light-transmissive electrode and the backplane. Such a display may be incorporated into an electronic book reader, portable computer, tablet computer, cellular telephone, smart card, sign, watch, shelf label or flash drive.

### BRIEF DESCRIPTION OF DRAWINGS

**[Para 25]** FIG. 1 is a schematic cross-section showing the positions of the various colored particles in an electrophoretic medium of the present invention when displaying black, white, the three subtractive primary and the three additive primary colors.

**[Para 26]** FIG. 2A is a general illustration of an electrophoretic display having four types of particles in a non-polar fluid, wherein a full range of colors is available at each pixel electrode. It is understood that in some embodiments, a type of negatively-charged particle is white, one type of positively charged particle is yellow, one type of positively charged particle is magenta, and one type of positively charged particle is cyan, however, the invention is not limited to the exemplary color sets.

**[Para 27]** FIG. 2B illustrates a transition between a first optical state having all of the particles of a first charge polarity at the viewing surface and a second optical state having the particles with the second (opposite) polarity at the viewing surface.

**[Para 28]** FIG. 2C illustrates a transition between a first optical state having all of the particles of the first charge polarity at the viewing surface and a third optical state having the particles with the second (opposite) polarity behind the middle charged particles of the first polarity, which are located at the viewing surface.

**[Para 29]** FIG. 2D illustrates a transition between a first optical state having all of the particles of the first charge polarity at the viewing surface and a fourth optical state having the particles with the second (opposite) polarity behind the low charged particles of the first polarity, which

are located at the viewing surface.

**[Para 30]** FIG. 2E illustrates a transition between a first optical state having all of the particles of the first charge polarity at the viewing surface and a fifth optical state having the particles with the second (opposite) polarity behind a combination of the low charged particles and the medium charged particles of the first polarity, which are located at the viewing surface.

**[Para 31]** FIG. 3 illustrates an exemplary equivalent circuit of a single pixel of an electrophoretic display.

**[Para 32]** FIG. 4 shows the layers of an exemplary electrophoretic color display.

**[Para 33]** FIG. 5 shows exemplary push-pull drive schemes for addressing an electrophoretic medium including three subtractive particles and a scattering (white) particle.

**[Para 34]** FIG. 6A shows the maximum rates of change of optical density in an electrophoretic medium including white, yellow, magenta, and cyan particles with zeta potentials of  $-35\text{mV}$ ,  $-22\text{mV}$ ,  $+54\text{mV}$ , and  $+70\text{mV}$ , respectively. The measured rates of change are plotted for each non-white particle when pulses of 500ms duration are applied at the voltages indicated on the x-axes.

**[Para 35]** FIG. 6B shows measured colors as a function of voltage and time for the electrophoretic medium of FIG. 6A. The electrophoretic medium with a yellow particle having a zeta potential of  $-22\text{mV}$  only produces a clean white state over a narrow range of voltage and time.

**[Para 36]** FIG. 7A shows the maximum rates of change of optical density in an electrophoretic medium including white, yellow, magenta, and cyan particles with zeta potentials of  $-35\text{mV}$ ,  $+22\text{mV}$ ,  $+54\text{mV}$ , and  $+70\text{mV}$ , respectively. The measured rates of change are plotted for each non-white particle when pulses of 500ms duration are applied at the voltages indicated on the x-axes.

**[Para 37]** FIG. 7B shows measured colors as a function of voltage and time for the electrophoretic medium of FIG. 7A. The electrophoretic medium with a yellow particle having a zeta potential of  $+22\text{mV}$  produces a clean white state over a much wider range of voltage and time.

**[Para 38]** FIG. 8 shows the colors that are obtainable in an electrophoretic fluid including white, yellow, magenta, and cyan particles with zeta potentials of  $-35\text{mV}$ ,  $+22\text{mV}$ ,  $+54\text{mV}$ , and  $+70\text{mV}$ , respectively.

## DETAILED DESCRIPTION

**[Para 39]** The invention includes improved four-particle electrophoretic media, including a first particle of a first polarity, and three other particles having the opposite polarity, but having different magnitudes of charge. Typically, such a system includes a negative white particle and yellow, magenta, and cyan positively-charged particles having subtractive primary colors. Additionally, some particles may be engineered so that their electrophoretic mobility is non-linear with respect to the strength of the applied electric field. Accordingly, one or more particles will experience a decrease in electrophoretic mobility with the application of a high electric field (e.g., 20V or greater) of the correct polarity. Such a four-particle system is shown schematically in FIG. 1, and it can provide white, yellow, red, magenta, blue, cyan, green, and black at every pixel.

**[Para 40]** As shown in FIG. 1, each of the eight principal colors (red, green, blue, cyan, magenta, yellow, black and white) corresponds to a different arrangement of the four particles, such that the viewer only sees those colored particles that are on the viewing side of the white particle (i.e., the only particle that scatters light). To achieve a wide range of colors, additional voltage levels must be used for finer control of the particles. In the formulations described, the first (typically negative) particle is reflective (typically white), while the other three particles oppositely charged (typically positive) particles include three substantially non-light-scattering (“SNLS”). The use of SNLS particles allows mixing of colors and provides for more color outcomes than can be achieved with the same number of scattering particles. These thresholds must be sufficiently separated for avoidance of cross-talk, and this separation necessitates the use of high addressing voltages for some colors. The disclosed four-particle electrophoretic media can also be updated faster, require “less flashy” transitions, and produce color spectra that is more pleasing to the viewer (and thus, commercially more valuable). Additionally, the disclosed formulations provides for fast (e.g., less than 500 ms, e.g., less than 300 ms, e.g., less than 200 ms, e.g., less than 100 ms) updates between black and white pixels, thereby enabling fast page turns for black on white text.

**[Para 41]** In FIG. 1, it is assumed that the viewing surface of the display is at the top (as illustrated), i.e., a user views the display from this direction, and light is incident from this direction. As already noted, in preferred embodiments only one of the four particles used in the electrophoretic medium of the present invention substantially scatters light, and in FIG. 1 this particle is assumed to be the white pigment. This light-scattering white particle forms a white reflector against which any particles above the white particles (as illustrated in FIG. 1)

are viewed. Light entering the viewing surface of the display passes through these particles, is reflected from the white particles, passes back through these particles and emerges from the display. Thus, the particles above the white particles may absorb various colors and the color appearing to the user is that resulting from the combination of particles above the white particles. Any particles disposed below (behind from the user's point of view) the white particles are masked by the white particles and do not affect the color displayed. Because the second, third and fourth particles are substantially non-light-scattering, their order or arrangement relative to each other is unimportant, but for reasons already stated, their order or arrangement with respect to the white (light-scattering) particles is critical.

**[Para 42]** More specifically, when the cyan, magenta and yellow particles lie below the white particles (Situation [A] in FIG. 1), there are no particles above the white particles and the pixel simply displays a white color. When a single particle is above the white particles, the color of that single particle is displayed, yellow, magenta and cyan in Situations [B], [D] and [F] respectively in FIG. 1. When two particles lie above the white particles, the color displayed is a combination of those of these two particles; in FIG. 1, in Situation [C], magenta and yellow particles display a red color, in Situation [E], cyan and magenta particles display a blue color, and in Situation [G], yellow and cyan particles display a green color. Finally, when all three colored particles lie above the white particles (Situation [H] in FIG. 1), all the incoming light is absorbed by the three subtractive primary colored particles and the pixel displays a black color.

**[Para 43]** It is possible that one subtractive primary color could be rendered by a particle that scatters light, so that the display would comprise two types of light-scattering particle, one of which would be white and another colored. In this case, however, the position of the light-scattering colored particle with respect to the other colored particles overlying the white particle would be important. For example, in rendering the color black (when all three colored particles lie over the white particles) the scattering colored particle cannot lie over the non-scattering colored particles (otherwise they will be partially or completely hidden behind the scattering particle and the color rendered will be that of the scattering colored particle, not black).

**[Para 44]** FIG. 1 shows an idealized situation in which the colors are uncontaminated (i.e., the light-scattering white particles completely mask any particles lying behind the white particles). In practice, the masking by the white particles may be imperfect so that there may be some small absorption of light by a particle that ideally would be completely masked. Such

contamination typically reduces both the lightness and the chroma of the color being rendered. In the electrophoretic medium of the present invention, such color contamination should be minimized to the point that the colors formed are commensurate with an industry standard for color rendition. A particularly favored standard is SNAP (the standard for newspaper advertising production), which specifies  $L^*$ ,  $a^*$  and  $b^*$  values for each of the eight primary colors referred to above. (Hereinafter, “primary colors” will be used to refer to the eight colors, black, white, the three subtractive primaries and the three additive primaries as shown in FIG. 1.)

**[Para 45]** FIGS. 2A-2E show schematic cross-sectional representations of the four particle types) used in the invention. . A display layer utilizing the improved electrophoretic medium includes a first (viewing) surface 13 on the viewing side, and a second surface 14 on the opposite side of the first surface 13. The electrophoretic medium is disposed between the two surfaces. Each space between two dotted vertical lines denotes a pixel. Within each pixel the electrophoretic medium can be addressed and the viewing surface 13 of each pixel can achieve the color states shown in FIG. 1 without a need for additional layers, and without a color filter array.

**[Para 46]** As standard with electrophoretic displays, the first surface 13 includes a common electrode 11 which is light-transmissive, for example, constructed from a sheet of PET with indium tin oxide (ITO) disposed thereon.. On the second surface (14), there is an electrode layer 12 which includes a plurality of pixel electrodes 15. Such pixel electrodes are described in US Patent No. 7,046,228, the content of which is incorporated herein by reference in its entirety. It is noted that while active matrix driving with a thin film transistor (TFT) backplane is mentioned for the layer of pixel electrodes, the scope of the present invention encompasses other types of electrode addressing as long as the electrodes serve the desired functions. For example, the top and bottom electrodes can be contiguous. Additionally, pixel electrode backplanes different from those described in the ‘228 patent are also suitable, and may include active matrix backplanes capable of providing higher driving voltages than typically found with amorphous silicon thin-film-transistor backplanes.

**[Para 47]** Newly-developed active matrix backplanes may include thin film transistors incorporating metal oxide materials, such as tungsten oxide, tin oxide, indium oxide, zinc oxide or more complex metal oxides such as indium gallium zirconium oxide. In these applications, a channel formation region is formed for each transistor using such metal oxide materials, allowing faster switching of higher voltages. Such metal oxide transistors also allow for less

leakage in the “off” state of the thin-film transistor (TFT) than can be achieved by, for example, amorphous silicon TFTs. In a typical scanning TFT backplane comprising  $n$  lines, the transistor will be in the “off” state for approximately a proportion  $(n-1)/n$  of the time required to refresh every line of the display. Any leakage of charge from the storage capacitors associated with each pixel would result in degradation of the electro-optical performance of the display. TFTs typically include a gate electrode, a gate-insulating film (typically  $\text{SiO}_2$ ), a metal source electrode, a metal drain electrode, and a metal oxide semiconductor film over the gate-insulating film, at least partially overlapping the gate electrode, source electrode, and drain electrode. Such backplanes are available from manufacturers such as Sharp/Foxconn, LG, and BOE. Such backplanes are able to provide driving voltages of  $\pm 30\text{V}$  (or more). In some embodiments, intermediate voltage drivers are included so that the resulting driving waveforms may include five levels, or seven levels, or nine levels, or more.

**[Para 48]** One preferred metal oxide material for such applications is indium gallium zinc oxide (IGZO). IGZO-TFT has 20–50 times the electron mobility of amorphous silicon. By using IGZO TFTs in an active matrix backplane, it is possible to provide voltages of greater than 30V via a suitable display driver. Furthermore, a source driver capable of supplying at least five, and preferably seven levels provides a different driving paradigm for a four-particle electrophoretic display system. In an embodiment, there will be two positive voltages, two negative voltages, and zero volts. In another embodiment, there will be three positive voltages, three negative voltages, and zero volts. In an embodiment, there will be four positive voltages, four negative voltages, and zero volts. These levels may be chosen within the range of about -27V to +27V, without the limitations imposed by top plane switching as described above.

**[Para 49]** An electrophoretic medium of the invention includes four types of electrophoretic particles in a non-polar fluid 17, as shown in FIGS. 2A-2E. A first particle ( $W^-*$ ; open circle) is negatively charged and may be surface treated so that the electrophoretic mobility of the first particle is dependent upon the strength of the driving electric field (discussed in greater detail below). In such instances, the electrophoretic mobility of the particle actually decreases in the presence of a stronger electric field, which is somewhat counter-intuitive. A second particle ( $M^{++*}$ ; dark circle) is positively charged, and may also be surface treated (or purposely untreated) so that either the electrophoretic mobility of the second particle is dependent upon the strength of the driving electric field, or the rate of unpacking of a collection of the second particle, after having been driven to one side of the cavity containing the particles upon reversal of the electric field direction, is slower than the rate of unpacking of collections of the third

and fourth particles. A third particle (Y+; checkered circle) is positive, but has a charge magnitude that is smaller than the second particle. Additionally, the third particle may be surface treated, but not in a way that causes the electrophoretic mobility of the third particle to depend upon the strength of the driving electric field. That is, the third particle may have a surface treatment, however such a surface treatment does not result in the aforementioned reduction in electrophoretic mobility with an increased electric field. The fourth particle (C+++; gray circle) has the highest magnitude positive charge and the same type of surface treatment as the third particle. As indicated in FIG. 2A, the particles are nominally white, magenta, yellow, and cyan in color to produce colors as shown in FIG. 1. However, the invention is not limited to this specific color set, nor is it limited to one reflective particle and three absorptive particles. For example, the system could include one black absorptive particle and three reflective particles of red, yellow, and blue with suitably matched reflectance spectra to produce a process white state when all three reflective particles are mixed and viewable at the surface.

**[Para 50]** In a preferred embodiment, the first particle (negative) is white and scattering. The second particle (positive, medium charge magnitude) is magenta and absorptive. The third particle (positive, low charge magnitude) is yellow and absorptive. The fourth particle (positive, high charge magnitude) is cyan and absorptive. Table 1 below shows the diffuse reflectance of exemplary yellow, magenta, cyan and white particles useful in electrophoretic media of the present invention, together with the ratio of their absorption and scattering coefficients according to the Kubelka-Munk analysis of these materials as dispersed in a poly(isobutylene) matrix.

**Table 1.** Diffuse reflectance of preferred yellow, magenta, cyan and white particles.

		Diffuse reflectance of 1 $\mu$ m layer on 0% black			Ratio absorption / scatter		
Color	Volume Fraction	450 nm	550 nm	650 nm	K/S 450nm	K/S 550nm	K/S 650nm
Yellow (Y1)	0.097	4.5%	0.9%	0.5%	9.67	0.38	0.63
Yellow (Y1)	0.147	4.4%	0.9%	0.4%	9.84	0.25	0.02
Magenta (M1)	0.115	2.8%	3.8%	0.7%	10.01	10.85	1.27
Magenta (M1)	0.158	3.2%	4.1%	1.0%	10.00	10.75	1.64

Magenta (M1)	0.190	3.4%	4.1%	1.3%	10.09	10.80	1.03
Cyan (C1)	0.112	1.3%	3.7%	4.3%	7.27	11.17	10.22
Cyan (C1)	0.157	1.5%	3.8%	4.3%	7.41	11.30	10.37
Cyan (C1)	0.202	1.7%	3.9%	4.3%	7.21	11.56	10.47
White (W1)	0.147	8.1%	6.2%	4.8%	0.0015	0.0020	0.0026
White (W1)	0.279	24.9%	20.6%	17.0%	0.0003	0.0003	0.0004
White (W1)	0.339	26.3%	21.7%	18.1%	0.0001	0.0002	0.0002

**[Para 51]** The electrophoretic medium of the present invention may be in any of the forms discussed above. Thus, the electrophoretic medium may be unencapsulated, encapsulated in discrete capsules surrounded by capsule walls, encapsulated in sealed microcells, or in the form of a polymer-dispersed medium. The pigments are described in detail elsewhere, such as in U.S. Patent Nos. 9,697,778. and 9,921,451. Briefly, white particle W1 is a silanol-functionalized light-scattering pigment (titanium dioxide) to which a polymeric material comprising lauryl methacrylate (LMA) monomers has been attached as described in U.S. Patent No. 7,002,728. White particle W2 is a polymer-coated titania produced substantially as described in Example 1 of United States Patent No. 5,852,196, with a polymer coating comprising an approximately 99:1 ratio of lauryl methacrylate and 2,2,2-trifluoroethyl methacrylate. Yellow particle Y1 is C.I. Pigment Yellow 180, used without coating and dispersed by attrition in the presence of Solsperse 19000, as described generally in U.S. Patent No. 9,697,778. Yellow particle Y2 is C.I. Pigment Yellow 155 used without coating and dispersed by attrition in the presence of Solsperse 19000, as described generally in in U.S. Patent No. 9,697,778. Yellow particle Y3 is C.I. Pigment Yellow 139, used without coating and dispersed by attrition in the presence of Solsperse 19000, as described generally in in U.S. Patent No. 9,697,778. Yellow particle Y4 is C.I. Pigment Yellow 139, which is coated by dispersion polymerization, incorporating trifluoroethyl methacrylate, methyl methacrylate and dimethylsiloxane-containing monomers as described in Example 4 of U.S. Patent No. 9,921,451. Magenta particle M1 is a positively-charged magenta material (dimethylquinacridone, C.I. Pigment Red 122) coated using vinylbenzyl chloride and LMA as described in U.S. Patent No. 9,697,778 and in Example 5 of U.S. Patent No. 9,921,451.

**[Para 52]** Magenta particle M2 is a C.I. Pigment Red 122 which is coated by dispersion polymerization, methyl methacrylate and dimethylsiloxane-containing monomers as described

in Example 6 of U.S. Patent No. 9,921,451. Cyan particle C1 is a copper phthalocyanine material (C.I. Pigment Blue 15:3) which is coated by dispersion polymerization, incorporating methyl methacrylate and dimethylsiloxane-containing monomers as described in Example 7 of U.S. Patent No. 9,921,451. In some embodiments, it has been found that the color gamut is improved by using Ink Jet Yellow 4GC (Clariant) as the core yellow pigment, with incorporation of methyl methacrylate surface polymers. The zeta potential of this yellow pigment can be tuned with the addition of 2,2,2-trifluoroethyl methacrylate (TFEM) monomers and monomethacrylate terminated poly(dimethylsiloxane).

**[Para 53]** Electrophoretic media additives and surface treatments for facilitating differential electrophoretic mobility, as well as proposed mechanisms for interaction between the surface treatment and surrounding charge control agents and/or free polymers, are discussed in detail in U.S. Patent No. 9,697,778, incorporated by reference in its entirety. In such electrophoretic media, one way of controlling the interactions among the various types of particles is by controlling the kind, amount, and thickness of polymeric coatings on the particles. For example, to control the particle characteristics such that the particle-particle interactions are less between the second type of particles and the third and fourth types of particles than between, for example, the third type of particles and the fourth type of particles of the third species, the second type of particle may bear a polymeric surface treatment, while the third and fourth types of particles bear either no polymeric surface treatment or a polymeric surface treatment having a lower mass coverage per unit area of the particle surface than the second type of particles. More generally, the Hamaker constant (which is a measure of the strength of the Van der Waals interaction between two particles, the pair potential being proportional to the Hamaker constant and inversely proportional to the sixth power of the distance between the two particles) and/or the interparticle spacing need(s) to be adjusted by judicious choice of the polymeric coating(s) on the three species of particles.

**[Para 54]** As discussed in U.S. Patent No. 9,921,451, different types of polymers may include different types of polymer surface treatment. For example, Coulombic interactions may be weakened when the closest distance of approach of oppositely-charged particles is maximized by a steric barrier (typically a polymer grafted or adsorbed to the surface of one or both particles). The polymer shell may be a covalently-bonded polymer made by grafting processes or chemisorption as is well known in the art, or may be physisorbed onto the particle surface. For example, the polymer may be a block copolymer comprising insoluble and soluble segments. Alternatively, the polymer shell may be dynamic in that it is a loose network of free

polymer from the electrophoretic medium that is complexed with a pigment particle in the presence of an electric field and a sufficient amount and kind of charge control agent (CCA – discussed below). Thus, depending upon the strength and polarity of the electric field, a particle may have more associated polymer, which causes the particle to interact differently with the container (e.g., microcapsule or microcell) and the other particles. [The extent of the polymer shell is conveniently assessed by thermal gravimetric analysis (TGA), a technique in which the temperature of a dried sample of the particles is raised and the mass loss due to pyrolysis is measured as a function of temperature. Using TGA, the proportion of the mass of the particle that is polymer can be measured, and this can be converted to a volume fraction using the known densities of the core pigments and the polymers attached to them.] Conditions can be found in which the polymer coating is lost but the core pigment remains (these conditions depend upon the precise core pigment particle used). A variety of polymer combinations can be made to work as described below with respect to FIGS. 2A-2E. For example, in some embodiments a particle (typically the first and/or second particle) can have a covalently-attached polymer shell that interacts strongly with the container (e.g., microcell or microcapsule). Meanwhile the other particles of the same charge have no polymer coating or complex with free polymers in the solution so that those particles have little interaction with the container. In other embodiments, a particle (typically the first and/or second particle) will have no surface coating so that it is easier for that particle to form a charge double layer and experience electrophoretic mobility reduction in the presence of strong fields.

**[Para 55]** The fluid 17 in which the four types of particles are dispersed is clear and colorless. The fluid contains the charged electrophoretic particles, which move through the fluid under the influence of an electric field. A preferred suspending fluid has a low dielectric constant (about 2), high volume resistivity (about  $10^{15}$  Ohm.cm), low viscosity (less than 5 mPas), low toxicity and environmental impact, low water solubility (less than 10 parts per million (ppm), if traditional aqueous methods of encapsulation are to be used; note however that this requirement may be relaxed for non-encapsulated or certain microcell displays), a high boiling point (greater than about  $90^{\circ}\text{C}$ ), and a low refractive index (less than 1.5). The last requirement arises from the use of scattering (typically white) pigments of high refractive index, whose scattering efficiency depends upon a mismatch in refractive index between the particles and the fluid.

**[Para 56]** Organic solvents such as saturated linear or branched hydrocarbons, silicone oils, halogenated organic solvents, and low molecular weight halogen-containing polymers are

some useful fluids. The fluid may comprise a single component or may be a blend of more than one component in order to tune its chemical and physical properties. Reactants or solvents for the microencapsulation process (if used), such as oil soluble monomers, can also be contained in the fluid.

**[Para 57]** The fluid preferably has a low viscosity and a dielectric constant in the range of about 2 to about 30, preferably about 2 to about 15 for high particle mobility. Examples of suitable dielectric fluids include hydrocarbons such as Isopar®, decahydronaphthalene (DECALIN), 5-ethylidene-2-norbornene, fatty oils, paraffin oil, silicon fluids, aromatic hydrocarbons such as toluene, xylene, phenylxylylethane, dodecylbenzene or alkylnaphthalene, halogenated solvents such as perfluorodecalin, perfluorotoluene, perfluoroxylene, dichlorobenzotrifluoride, 3,4,5 -trichlorobenzotrifluoride, chloropentafluorobenzene, dichlorononane or pentachlorobenzene, and perfluorinated solvents such as FC-43, FC-70 or FC-5060 from 3M Company, St. Paul MN, low molecular weight halogen containing polymers such as poly(perfluoropropylene oxide) from TCI America, Portland, Oregon, poly(chlorotrifluoro-ethylene) such as Halocarbon Oils from Halocarbon Product Corp., River Edge, NJ, perfluoropolyalkylether such as Galden from Ausimont or Krytox Oils and Greases K-Fluid Series from DuPont, Delaware, polydimethylsiloxane based silicone oil from Dow-corning (DC -200).

**[Para 58]** The electrophoretic media typically also include one or more charge control agents (CCA), and may also include a charge director. CCA and charge directors typically comprise low molecular weight surfactants, polymeric agents, or blends of one or more components and serve to stabilize or otherwise modify the sign and/or magnitude of the charge on the electrophoretic particles. The CCA is typically a molecule comprising ionic or other polar groupings, hereinafter referred to as head groups. At least one of the positive or negative ionic head groups is preferably attached to a non-polar chain (typically a hydrocarbon chain) that is hereinafter referred to as a tail group. It is thought that the CCA forms reverse micelles in the internal phase and that it is a small population of charged reverse micelles that leads to electrical conductivity in the very non-polar fluids typically used as electrophoretic fluids.

**[Para 59]** The addition of CCAs provides for the production of reverse micelles including a highly polar core that may vary in size from 1 nm to tens of nanometers (and may have spherical, cylindrical, or other geometry) surrounded by the non-polar tail groups of the CCA molecule. In electrophoretic media, three phases may typically be distinguished: a solid particle having a surface, a highly polar phase that is distributed in the form of extremely small

droplets (reverse micelles), and a continuous phase that comprises the fluid. Both the charged particles and the charged reverse micelles may move through the fluid upon application of an electric field, and thus there are two parallel pathways for electrical conduction through the fluid (which typically has a vanishingly small electrical conductivity itself).

**[Para 60]** The polar core of the CCA is thought to affect the charge on surfaces by adsorption onto the surfaces. In an electrophoretic display, such adsorption may be onto the surfaces of the electrophoretic particles or the interior walls of a microcapsule (or other solid phase, such as the walls of a microcell) to form structures similar to reverse micelles, these structures hereinafter being referred to as hemi-micelles. When one ion of an ion pair is attached more strongly to the surface than the other (for example, by covalent bonding), ion exchange between hemi-micelles and unbound reverse micelles can lead to charge separation in which the more strongly bound ion remains associated with the particle and the less strongly bound ion becomes incorporated into the core of a free reverse micelle.

**[Para 61]** It is also possible that the ionic materials forming the head group of the CCA may induce ion-pair formation at the particle (or other) surface. Thus the CCA may perform two basic functions: charge-generation at the surface and charge-separation from the surface. The charge-generation may result from an acid-base or an ion-exchange reaction between some moiety present in the CCA molecule or otherwise incorporated into the reverse micelle core or fluid, and the particle surface. Thus, useful CCA materials are those which are capable of participating in such a reaction, or any other charging reaction as known in the art.

**[Para 62]** Non-limiting classes of charge control agents which are useful in the media of the present invention include organic sulfates or sulfonates, metal soaps, block or comb copolymers, organic amides, organic zwitterions, and organic phosphates and phosphonates. Useful organic sulfates and sulfonates include, but are not limited to, sodium bis(2-ethylhexyl) sulfosuccinate, calcium dodecylbenzenesulfonate, calcium petroleum sulfonate, neutral or basic barium dinonylnaphthalene sulfonate, neutral or basic calcium dinonylnaphthalene sulfonate, dodecylbenzenesulfonic acid sodium salt, and ammonium lauryl sulfate. Useful metal soaps include, but are not limited to, basic or neutral barium petronate, calcium petronate, cobalt, calcium, copper, manganese, magnesium, nickel, zinc, aluminum and iron salts of carboxylic acids such as naphthenic, octanoic, oleic, palmitic, stearic, and myristic acids and the like. Useful block or comb copolymers include, but are not limited to, AB diblock copolymers of (A) polymers of 2-(N,N-dimethylamino)ethyl methacrylate quaternized with methyl p-toluenesulfonate and (B) poly(2-ethylhexyl methacrylate), and comb graft

copolymers with oil soluble tails of poly(12-hydroxystearic acid) and having a molecular weight of about 1800, pendant on an oil-soluble anchor group of poly(methyl methacrylate-methacrylic acid). Useful organic amides/amines include, but are not limited to, polyisobutylene succinimides such as OLOA 371 or 1200 (available from Chevron Oronite Company LLC, Houston, Tex.), or SOLSPERSE 17000 or 19000 (available from Lubrizol, Wickliffe, OH: Solsperser is a Registered Trade Mark), and N-vinylpyrrolidone polymers. Useful organic zwitterions include, but are not limited to, lecithin. Useful organic phosphates and phosphonates include, but are not limited to, the sodium salts of phosphated mono- and diglycerides with saturated and unsaturated acid substituents. Useful tail groups for CCA include polymers of olefins such as poly(isobutylene) of molecular weight in the range of 200 – 10,000. The head groups may be sulfonic, phosphoric or carboxylic acids or amides, or alternatively amino groups such as primary, secondary, tertiary or quaternary ammonium groups. One class of CCAs that are useful in the disclosed four-particle electrophoretic media are disclosed in U.S. Patent Publication No. 2017/0097556, incorporated by reference herein in its entirety. Such CCAs typically include a quaternary amine head group and an unsaturated polymeric tail, i.e., including at least one C-C double bond. The polymeric tail is typically a fatty acid tail. A variety of CCA molecular weights can be used. In some embodiments, the molecular weight of the CCA is 12,000 grams/mole or greater, for example between 14,000 grams/mole and 22,000 grams/mole.

**[Para 63]** Charge adjuvants used in the media of the present invention may bias the charge on electrophoretic particle surfaces, as described in more detail below. Such charge adjuvants may be Bronsted or Lewis acids or bases. Exemplary charge adjuvants are disclosed in U.S. Patent Nos. 9,765,015, 10,233,339 and 10,782,586, all of which are incorporated by reference in their entireties. Exemplary adjuvants may include polyhydroxy compounds which contain at least two hydroxyl groups include, but are not limited to, ethylene glycol, 2,4,7,9-tetramethyldecyne-4,7-diol, poly(propylene glycol), pentaethylene glycol, tripropylene glycol, triethylene glycol, glycerol, pentaerythritol, glycerol tris(12-hydroxystearate), propylene glycerol monohydroxystearate, and ethylene glycol monohydroxystearate. Examples of aminoalcohol compounds which contain at least one alcohol function and one amine function in the same molecule include, but are not limited to, triisopropanolamine, triethanolamine, ethanolamine, 3-amino-1-propanol, o-aminophenol, 5-amino-1-pentanol, and tetrakis(2-hydroxyethyl)ethylenediamine. In some embodiments, the charge adjuvant is present in the

electrophoretic display medium in an amount of between about 1 to about 500 milligrams per gram (“mg/g”) of the particle mass, and more preferably between about 50 to about 200 mg/g.

**[Para 64]** Particle dispersion stabilizers may be added to prevent particle flocculation or attachment to the capsule or other walls or surfaces. For the typical high resistivity liquids used as fluids in electrophoretic displays, non-aqueous surfactants may be used. These include, but are not limited to, glycol ethers, acetylenic glycols, alkanolamides, sorbitol derivatives, alkyl amines, quaternary amines, imidazolines, dialkyl oxides, and sulfosuccinates.

**[Para 65]** As described in U.S. Patent No. 7,170,670, the bistability of electrophoretic media can be improved by including in the fluid a polymer having a number average molecular weight in excess of about 20,000, this polymer being essentially non-absorbing on the electrophoretic particles; poly(isobutylene) is a preferred polymer for this purpose. Also, as described in for example, U.S. Patent No. 6,693,620, a particle with immobilized charge on its surface sets up an electrical double layer of opposite charge in a surrounding fluid. Ionic head groups of the CCA may be ion-paired with charged groups on the electrophoretic particle surface, forming a layer of immobilized or partially immobilized charged species. Outside this layer is a diffuse layer comprising charged (reverse) micelles comprising CCA molecules in the fluid. In conventional DC electrophoresis an applied electric field exerts a force on the fixed surface charges and an opposite force on the mobile counter-charges, such that slippage occurs within the diffuse layer and the particle moves relative to the fluid. The electric potential at the slip plane is known as the zeta potential.

**[Para 66]** As a result, some of the particle types within the electrophoretic medium have different electrophoretic mobilities depending upon the strength of the electric field across the electrophoretic medium. For example, when a first (low strength, i.e., around  $\pm 10V$  or less) electric field is applied to the electrophoretic medium, the first type of particles move in one direction relative to the electric field, however, when a second (high strength, i.e., around  $\pm 20V$  or more) electric field is applied, *having the same polarity as the first electric field*, the first type of particles begins to move in the opposite direction relative to the electric field. It is theorized that the behavior results from conduction within the highly non-polar fluid being mediated by charged reverse micelles or counter-charged electrophoretic particles. Accordingly, any electrochemically-generated protons (or other ions) are probably transported through the non-polar fluid in micelle cores or adsorbed on electrophoretic particles. For example, as illustrated in Figure 5B of U.S. Patent No. 9,697,778, a positively-charged reverse micelle may approach a negative electrophoretic particle traveling in the opposite direction,

wherein the reverse micelle is incorporated into the electric double layer around the negatively charged particle. (The electric double layer includes both the diffuse layer of charge with enhanced counter-ion concentration and the hemi-micellar surface-adsorbed coating on the particle; in the latter case, the reverse micelle charge would become associated with the particle within the slip envelope that, as noted above, defines the zeta potential of the particle.) Through this mechanism, an electrochemical current of positively-charged ions flows through the electrophoretic fluid, and the negatively-charged particles may become biased towards a more positive charge. As a result, the electrophoretic mobility, e.g., of the first negative type of particle is a function of the magnitude of the electrochemical current and the residence time of a positive charge close to the particle surface, which is a function of the strength of the electric field.

**[Para 67]** Furthermore, as also described in U.S. Patent No. 9,697,778, positively-charged particles can be prepared that also exhibit different electrophoretic mobilities depending upon the applied electric field. In some embodiments, a secondary (or co-) CCA can be added to the electrophoretic medium to adjust the zeta potentials of the various particles. Careful selection of the co-CCA may allow alteration of the zeta potential of one particle while leaving those of the other particles essentially unchanged, allows close control of both the electrophoretic velocities of the various particles during switching and the inter-particle interactions.

**[Para 68]** In some embodiments, a portion of the charge control agents intended for the final formulation are added during synthesis of the electrophoretic particles to engineer the desired zeta potential and to influence the reduction in electrophoretic mobility due to a strong electric field. For example, it has been observed that adding quaternary amine charge control agents during polymer grafting will result in some amount of the CCA being complexed to the particles. (This can be confirmed by removing the particles from the electrophoretic fluid and subsequently stripping the surface species from the pigments with THF to remove all adsorbed species. When the THF extract is evaluated with <sup>1</sup>H NMR, it is clear that a good amount of the CCA was adsorbed to the pigment particles or complexed with the surface polymer.) Experiments suggest that high CCA loading amongst the surface polymers of the particles facilitates the formation of a charge double layer around the particle in the presence of a strong electric field. For example, magenta particles having greater than 200 mg of a charge control agent (CCA) per gram of finished magenta particle have excellent staying properties in the presence of a high positive electric field. (See, e.g., FIG. 2C, and the description above.) In some embodiments, the CCA includes a quaternary amine head group and a fatty acid tail. In

some embodiments the fatty acid tail is unsaturated. When some of the particles in the electrophoretic medium include high CCA loading, it is important that the particles for which consistent electrophoretic mobility is desired do not have substantial CCA loading, for example less than 50 mg of a charge control agent (CCA) per gram of finished particle, e.g., less than 10 mg of a charge control agent (CCA) per gram of finished particle.

**[Para 69]** In other embodiments, an electrophoretic medium including four types of particles, in the presence of Solsperse 17000 in Isopar E benefits from the additions of small amounts of acidic entities, such as, for example, aluminum salts of di-t-butyl salicylic acid (Bontron E-88, available from Orient Corporation, Kenilworth, NJ)). Addition of the acidic material moves the zeta potential of many particles (though not all) to more positive values. In one embodiment about 1% of the acidic material and 99% of Solsperse 17000 (based on total weight of the two materials) moves the zeta potential of the third type of particle (Y+) from -5mV to about+20mV. Whether or not the zeta potential of a particular particle is changed by a Lewis acidic material like the aluminum salt will depend upon the details of the surface chemistry of the particle.

**[Para 70]** Table 2 shows exemplary relative zeta potentials of the three types of colored and singular white particles in a preferred embodiment.

**Table 2.** Relative zeta potentials of colored particles in the presence of relative zeta potential of white particles.

		White zeta potential (mV)			
		-30	0	10	20
Cyan zeta potential (mV)	<b>80</b>	110	80	70	60
Magenta zeta potential (mV)	<b>40</b>	70	40	30	20
+Yellow zeta potential (mV)	<b>20</b>	50	20	10	0
-Yellow zeta potential (mV)	<b>-20</b>	10	-20	-30	-40

**[Para 71]** In an embodiment, the negative (white) particle has a zeta potential of -30mV, and the remaining three particles are all positive relative to the white particle. Accordingly, a display comprising positive cyan, magenta, and yellow particles can switch between a black state (with all colored particles in front of the white particle with respect to the viewing surface) and a white state, with the white particle closest to the viewer, and blocking the viewer from perceiving the remaining three particles. In contrast, when the white particle has a zeta potential of 0V, the negatively-charged yellow particle is the most negative of all the particles, and thus a display comprising this particle would switch between a yellow and a blue state. This would also occur if the white particle were positively charged. The positively-charged

yellow particle, however, would be more positive than the white particle unless its zeta potential exceeded +20mV.

**[Para 72]** The behavior of the electrophoretic media of the invention are consistent with the mobility of the white particle (represented in Table 2 as the zeta potential) being dependent upon the applied electric field. Thus, in the example illustrated in Table 2, when addressed with a low voltage the white particle might behave as though its zeta potential were -30mV, but when addressed with a higher voltage it might behave as though its zeta potential were more positive, maybe even as high as +20mV (matching the zeta potential of the yellow particle). Thus, when addressed with a low voltage the display would switch between black and white states but when addressed at a higher voltage would switch between blue and yellow states.

**[Para 73]** The motion of the various particles in the presence of a high (e.g., “±H”, e.g., ±20V, e.g., ±25V) electric field and a low (e.g., “±L”, e.g., ±5V, e.g., ±10V) electric field are shown in FIGS. 2B-2E. For the purposes of illustration, each box bounded by dashed lines represents a pixel bounded by a top light-transmissive electrode 21 and a bottom electrode 22, which may be a pixel electrode of an active matrix, however it may also be a light-transmissive electrode, or a segmented electrode, etc. Starting from a first state, in which all of the positive particles are present at the viewing surface (nominally black), the electrophoretic medium can be driven to four different optical states, as shown in FIGS. 2B-2E. In the preferred embodiment, this results in a white optical state (FIG. 2B), a magenta optical state (FIG. 2C), a yellow optical state (FIG. 2D), and a red optical state (FIG. 2E). It should be evident that the remaining four optical states of FIG. 1 can be achieved by reversing the order of the initial state and the driving electric fields, as shown in short hand in FIG. 5.

**[Para 74]** When addressed with a low voltage, as in FIG. 2B, the particles behave according to their relative zeta potentials with relative velocities illustrated by the arrows for the case when a negative voltage is applied to the backplane. Thus, in this example, the cyan particles move faster than the magenta particles, which move faster than the yellow particles. The first (positive) pulse does not change the positions of the particles, since they are already restricted in motion by the walls of the enclosure. The second (negative) pulse exchanges the positions of the colored and white particles, and thus the display switches between black and white states, albeit with transient colors reflecting the relative mobilities of the colored particles. Reversing the starting positions and polarities of the pulses allows for a transition from white to black. Accordingly, this embodiment provides black-white updates that require lower voltages (and

consume less power) as compared to other black and white formulations achieved with multiple colors via either a process black or a process white.

**[Para 75]** In FIG. 2C the first (positive) pulse is of a high positive voltage, sufficient to reduce the mobility of the magenta particle (i.e., the particle of intermediate mobility of the three positively-charge colored particles). Because of the reduced mobility, the magenta particles essentially remain frozen in place, and a subsequent pulse in the opposite direction, of low voltage, moves the cyan, white and yellow particles more than the magenta particles, thereby producing a magenta color at the viewing surface, with the negative white particles behind the magenta particles. Importantly, if the starting position and the polarities of the pulses are reversed, (equivalent to viewing the display from the side opposite the viewing surface, i.e., through electrode 22), this pulse sequence would produce a green color (i.e., a mixture of yellow and cyan particles).

**[Para 76]** In FIG. 2D the first pulse is of a low voltage that does not significantly reduce the mobility of the magenta particles or the white particles. However, the second pulse is of a high negative voltage that reduces the mobility of the white particles. This allows more effective racing between the three positive particles, such that the slowest type of particles (yellow in this example) remains visible in front of the white particle, whose movement was diminished with the earlier negative pulse. Notably, the yellow particles do not make it to the top surface of the cavity containing the particles. Importantly, if the starting position and the polarities of the pulses are reversed, (equivalent to viewing the display from the side opposite the viewing surface, i.e., through electrode 22), this pulse sequence would produce a blue color (i.e., a mixture of magenta and cyan particles).

**[Para 77]** Finally, FIG. 2E shows that when both pulses are of high voltage, the magenta particle mobility would be reduced by the first high positive pulse, and the racing between cyan and yellow would be enhanced by the reduction in white mobility caused by the second high negative pulse. This produces a red color. Importantly, if the starting position and the polarities of the pulses are reversed, (equivalent to viewing the display from the side opposite the viewing surface, i.e., through electrode 22), this pulse sequence would produce a cyan color.

**[Para 78]** To obtain a high-resolution display, individual pixels of a display must be addressable without interference from adjacent pixels. One way to achieve this objective is to provide an array of non-linear elements, such as transistors or diodes, with at least one non-linear element associated with each pixel, to produce an "active matrix" display. An addressing or pixel electrode, which addresses one pixel, is connected to an appropriate voltage source

through the associated non-linear element. Typically, when the non-linear element is a transistor, the pixel electrode is connected to the drain of the transistor, and this arrangement will be assumed in the following description, although it is essentially arbitrary and the pixel electrode could be connected to the source of the transistor. Conventionally, in high resolution arrays, the pixels are arranged in a two-dimensional array of rows and columns, such that any specific pixel is uniquely defined by the intersection of one specified row and one specified column. The sources of all the transistors in each column are connected to a single column electrode, while the gates of all the transistors in each row are connected to a single row electrode; again the assignment of sources to rows and gates to columns is conventional but essentially arbitrary, and could be reversed if desired. The row electrodes are connected to a row driver, which essentially ensures that at any given moment only one row is selected, i.e., that there is applied to the selected row electrode a select voltage such as to ensure that all the transistors in the selected row are conductive, while there is applied to all other rows a non-select voltage such as to ensure that all the transistors in these non-selected rows remain non-conductive. The column electrodes are connected to column drivers, which place upon the various column electrodes voltages selected to drive the pixels in the selected row to their desired optical states. (The aforementioned voltages are relative to a common front electrode which is conventionally provided on the opposed side of the electro-optic medium from the non-linear array and extends across the whole display.) After a pre-selected interval known as the "line address time" the selected row is deselected, the next row is selected, and the voltages on the column drivers are changed so that the next line of the display is written. This process is repeated so that the entire display is written in a row-by-row manner.

**[Para 79]** Conventionally, each pixel electrode has associated therewith a capacitor electrode such that the pixel electrode and the capacitor electrode form a capacitor; see, for example, International Patent Application WO 01/07961. In some embodiments, N-type semiconductor (e.g., amorphous silicon) may be used to form the transistors and the "select" and "non-select" voltages applied to the gate electrodes can be positive and negative, respectively.

**[Para 80]** Figure 3 of the accompanying drawings depicts an exemplary equivalent circuit of a single pixel of an electrophoretic display. As illustrated, the circuit includes a capacitor 10 formed between a pixel electrode and a capacitor electrode. The electrophoretic medium 20 is represented as a capacitor and a resistor in parallel. In some instances, direct or indirect coupling capacitance 30 between the gate electrode of the transistor associated with the pixel and the pixel electrode (usually referred to as a "parasitic capacitance") may create unwanted

noise to the display. Usually, the parasitic capacitance 30 is much smaller than that of the storage capacitor 10, and when the pixel rows of a display is being selected or deselected, the parasitic capacitance 30 may result in a small negative offset voltage to the pixel electrode, also known as a “kickback voltage”, which is usually less than 2 volts. In some embodiments, to compensate for the unwanted “kickback voltage”, a common potential  $V_{com}$ , may be supplied to the top plane electrode and the capacitor electrode associated with each pixel, such that, when  $V_{com}$  is set to a value equal to the kickback voltage ( $V_{KB}$ ), every voltage supplied to the display may be offset by the same amount, and no net DC-imbalance experienced.

**[Para 81]** Problems may arise, however, when  $V_{com}$  is set to a voltage that is not compensated for the kickback voltage. This may occur when it is desired to apply a higher voltage to the display than is available from the backplane alone. It is well known in the art that, for example, the maximum voltage applied to the display may be doubled if the backplane is supplied with a choice of a nominal  $+V$ ,  $0$ , or  $-V$ , for example, while  $V_{com}$  is supplied with  $-V$ . The maximum voltage experienced in this case is  $+2V$  (i.e., at the backplane relative to the top plane), while the minimum is zero. If negative voltages are needed, the  $V_{com}$  potential must be raised at least to zero. Waveforms used to address a display with positive and negative voltages using top plane switching must therefore have particular frames allocated to each of more than one  $V_{com}$  voltage setting.

**[Para 82]** A set of waveforms for driving a color electrophoretic display having four particles described in U.S. Patent No. 9,921,451, incorporated by reference herein. In U.S. Patent No. 9,921,451, seven different voltages are applied to the pixel electrodes: three positive, three negative, and zero. However, in some embodiments, the maximum voltages used in these waveforms are higher than that can be handled by amorphous silicon thin-film transistors. In such instances, suitable high voltages can be obtained by the use of top plane switching. When (as described above)  $V_{com}$  is deliberately set to  $V_{KB}$ , a separate power supply may be used. It is costly and inconvenient, however, to use as many separate power supplies as there are  $V_{com}$  settings when top plane switching is used. Furthermore, top plane switching is known to increase kickback, thereby degrading the stability of the color states.

**[Para 83]** A display device may be constructed using an electrophoretic fluid of the invention in several ways that are known in the prior art. The electrophoretic fluid may be encapsulated in microcapsules or incorporated into microcell structures that are thereafter sealed with a polymeric layer. The microcapsule or microcell layers may be coated or embossed onto a plastic substrate or film bearing a transparent coating of an electrically conductive material.

This assembly may be laminated to a backplane bearing pixel electrodes using an electrically conductive adhesive. Alternatively, the electrophoretic fluid may be dispensed directly on a thin open-cell grid that has been arranged on a backplane including an active matrix of pixel electrodes. The filled grid can then be top-sealed with an integrated protective sheet/light-transmissive electrode.

**[Para 84]** Figure 4 shows a schematic, cross-sectional drawing (not to scale) of a display structure 200 suitable for use with the invention. In display 200 the electrophoretic fluid is illustrated as being confined to microcells, although equivalent structures incorporating microcapsules may also be used. Substrate 202, which may be glass or plastic, bears pixel electrodes 204 that are either individually addressed segments or associated with thin film transistors in an active matrix arrangement. (The combination of substrate 202 and electrodes 204 is conventionally referred to as the back plane of the display.) Layer 206 is an optional dielectric layer according to the invention applied to the backplane. (Methods for depositing a suitable dielectric layer are described in U.S. Patent Application No. 16/862,750, incorporated by reference.) The front plane of the display comprises transparent substrate 222 that bears a transparent, electrically conductive coating 220. Overlying electrode layer 220 is an optional dielectric layer 218. Layer (or layers) 216 are polymeric layer(s) that may comprise a primer layer for adhesion of microcells to transparent electrode layer 220 and some residual polymer comprising the bottom of the microcells. The walls of the microcells 212 are used to contain the electrophoretic fluid 214. The microcells are sealed with layer 210 and the whole front plane structure is adhered to the backplane using electrically-conductive adhesive layer 208. Processes for forming the microcells are described in the prior art, e.g., in U.S. Patent No. 6,930,818. In some instance, the microcells are less than 20  $\mu\text{m}$  in depth, e.g., less than 15  $\mu\text{m}$  in depth, e.g., less than 12  $\mu\text{m}$  in depth, e.g., about 10  $\mu\text{m}$  in depth, e.g., about 8  $\mu\text{m}$  in depth.

**[Para 85]** Most commercial electrophoretic displays use amorphous silicon based thin-film transistors (TFTs) in the construction of active matrix backplanes (202/024) because of the wider availability of fabrication facilities and the costs of the various starting materials. Unfortunately, amorphous silicon thin-film transistors become unstable when supplied gate voltages that would allow switching of voltages higher than about  $\pm 15\text{V}$ . Nonetheless, as described below, the performance of ACeP is improved when the magnitudes of the high positive and negative voltages are allowed to exceed  $\pm 15\text{V}$ . Accordingly, as described in previous disclosures, improved performance is achieved by additionally changing the bias of the top light-transmissive electrode with respect to the bias on the backplane pixel electrodes,

also known as top-plane switching. Thus, if a voltage of +30V (relative to the backplane) is needed, the top plane may be switched to -15V while the appropriate backplane pixel is switched to +15V. Methods for driving a four-particle electrophoretic system with top-plane switching are described in greater detail in, for example, U.S. Patent No. 9,921,451.

**[Para 86]** These waveforms require that each pixel of the display can be driven at five different addressing voltages, designated  $+V_{\text{high}}$ ,  $+V_{\text{low}}$ , 0,  $-V_{\text{low}}$  and  $-V_{\text{high}}$ , illustrated as 30V, 15V, 0, -15V and -30V. In practice, it may be preferred to use a larger number of addressing voltages. If only three voltages are available (i.e.,  $+V_{\text{high}}$ , 0, and  $-V_{\text{high}}$ ) it may be possible to achieve the same result as addressing at a lower voltage (say,  $V_{\text{high}}/n$  where  $n$  is a positive integer  $> 1$ ) by addressing with pulses of voltage  $V_{\text{high}}$  but with a duty cycle of  $1/n$ .

**[Para 87]** Figure 5 shows typical waveforms (in simplified form) used to drive a four-particle color electrophoretic display system described above. Such waveforms have a “push-pull” structure: i.e., they consist of a dipole comprising two pulses of opposite polarity. The magnitudes and lengths of these pulses determine the color obtained. At a minimum, there should be five such voltage levels. Fig. 5 shows high and low positive and negative voltages, as well as zero volts. Typically, “low” (L) refers to a range of about 5 – 15V, while “high” (H) refers to a range of about 15 – 30V. In general, the higher the magnitude of the “high” voltages, the better the color gamut achieved by the display. In some embodiments an addition “medium” (M) level is used, which is typically around 15V; however, the value for M will depend somewhat on the composition of the particles, as well as the environment of the electrophoretic medium.

**[Para 88]** Although Fig. 5 shows the simplest dipoles required to form colors, it will be appreciated that practical waveforms may multiple repetitions of these patterns, or other patterns that are aperiodic and use more than five voltage levels.

**[Para 89]** Of course, achieving the desired color with the driving pulses of FIG. 5 is contingent on the particles starting the process from a known state, which is unlikely to be the last color displayed on the pixel. Accordingly, a series of reset pulses precede the driving pulses, which increases the amount of time required to update a pixel from a first color to a second color. The reset pulses are described in greater detail in U.S. Patent No. 10,593,272, incorporated by reference. The lengths of these pulses (refresh and address) and of any rests (i.e., periods of zero voltage between them) may be chosen so that the entire waveform (i.e., the integral of voltage with respect to time over the whole waveform) is DC balanced (i.e., the integral of voltage over time is substantially zero). DC balance can be achieved by adjusting the lengths

of the pulses and rests in the reset phase so that the net impulse supplied in the reset phase is equal in magnitude and opposite in sign to the net impulse supplied in the address phase, during which phase the display is switched to a particular desired color. As shown in the FIGS. 2B - 2E, however, the starting state for the eight primary colors is either a black or white state, which can be achieved with a sustained low voltage driving pulse. The simplicity of achieving this start state further reduces the time of updates between states, which is more pleasing for the user and also reduces the amount of power consumed (thus increasing battery life).

**[Para 90]** In addition, the foregoing discussion of the waveforms, and specifically the discussion of DC balance, ignores the question of kickback voltage. In practice, as previously, every backplane voltage is offset from the voltage supplied by the power supply by an amount equal to the kickback voltage  $V_{KB}$ . Thus, if the power supply used provides the three voltages  $+V$ ,  $0$ , and  $-V$ , the backplane would actually receive voltages  $V+V_{KB}$ ,  $V_{KB}$ , and  $-V+V_{KB}$  (note that  $V_{KB}$ , in the case of amorphous silicon TFTs, is usually a negative number). The same power supply would, however, supply  $+V$ ,  $0$ , and  $-V$  to the front electrode without any kickback voltage offset. Therefore, for example, when the front electrode is supplied with  $-V$  the display would experience a maximum voltage of  $2V+V_{KB}$  and a minimum of  $V_{KB}$ . Instead of using a separate power supply to supply  $V_{KB}$  to the front electrode, which can be costly and inconvenient, a waveform may be divided into sections where the front electrode is supplied with a positive voltage, a negative voltage, and  $V_{KB}$ . In addition to the kickback

## EXAMPLES

EXAMPLE 1 – Measuring rate of change in color density as a function of applied voltage.

**[Para 91]** The benefits of the invention have been confirmed experimentally. In particular two displays were prepared, similar to the construction of FIG. 4, wherein the microcells of one display were filled with a formulation including white, cyan, magenta and yellow particles with zeta potentials (as measured at low applied voltages) being, respectively,  $-35\text{mV}$ ,  $+70\text{mV}$ ,  $+54\text{mV}$ , and  $-22\text{mV}$ . A second display had the microcells filled with a formulation including white, cyan, magenta and yellow particles with zeta potentials (as measured at low applied voltages) being, respectively,  $-35\text{mV}$ ,  $+70\text{mV}$ ,  $+54\text{mV}$ , and  $+24\text{mV}$ . Using the pulse sequence of FIG. 5 (which work for both negative and positive yellow formulations), the rate of change of density was evaluated using an electro-optic measurement bench including a spectrophotometer. See D. Hertel, “Optical measurement standards for reflective e-paper to

predict colors displayed in ambient illumination environments,” Color Research & Application, 43, 6, (907-921), (2018).

**[Para 92]** Figure 6A shows the maximum rates of change of optical density corresponding to each of the positive particles in the first display when pulses of 500ms duration were applied at the voltages indicated on the x-axes. Figure 7A shows the maximum rates of change of optical density corresponding to each of the positive particles in the second display when pulses of 500ms duration were applied at the voltages indicated on the x-axes. It can be seen that as the voltage increases in magnitude, the maximum rate of change of density for all particles increases until, at about +/- 20V applied voltage, the rates of change decrease. Interestingly, this change in the rate of change occurs regardless of whether the yellow particle is positively or negatively charged, and is consistent with the exemplary numbers presented in Table 2. While the waveforms successfully deliver approximately the same maximum rate of change as a function of applied voltage for the cyan and magenta particles, it is notable that the curve for the yellow particle is much flatter in FIG. 6A versus FIG. 7A, which means that it is more difficult to “place” the negative yellow particle in the proper order between the other particles to achieve the desired optical state, as compared to the positive yellow particle.

**[Para 93]** The difference in control over the negative yellow versus the positive yellow manifests in yellower white states for displays including negative yellow particles as compared to displays having positive yellow particles. In FIGS. 6B and 7B, the voltage is shown on the x-axis and time on the y-axis, and the colors obtained are plotted. When the yellow particles have a negative charge (Figure 6A), the composition switches between black and white only when addressed in a narrow voltage range between about +/-7 and +/-10 volts (see dashed box). However, when the yellow particles are positively charged (Figure 7A) the display can render black and white from about +/-7 to about +/-24V (see dashed box) Accordingly, electrophoretic media including positively-charged yellow particles are superior for applications that require regular updates between black and white pixels, such as an e-reader or time table. That is, there is a much wider window of addressing voltages in which the display switches between black and white states. Furthermore, as mentioned with respect to Table 2, if the yellow particle is negatively charged, above a certain threshold voltage the display will simply not switch between black and white, but rather between yellow and blue states.

EXAMPLE 2 – color gamut of electrophoretic medium including positive yellow particles.

**[Para 94]** A plurality of optical states beyond the eight primary states were measured for the second display of EXAMPLE 1 by driving the display with longer and more complex waveforms to and measuring the  $L^*a^*b^*$  values using a spectrophotometric electro-optic test bench. The measurements suggest a gamut of tens of thousands of colors with an excellent black white contrast ratio, as shown in FIG. 8.

**[Para 95]** Thus, the invention provides for full color electrophoretic media that provide for fast switching between high-quality white and black states. Having thus described several aspects and embodiments of the technology of this application, it is to be appreciated that various alterations, modifications, and improvements will readily occur to those of ordinary skill in the art. Such alterations, modifications, and improvements are intended to be within the spirit and scope of the technology described in the application. For example, those of ordinary skill in the art will readily envision a variety of other means and/or structures for performing the function and/or obtaining the results and/or one or more of the advantages described herein, and each of such variations and/or modifications is deemed to be within the scope of the embodiments described herein. Those skilled in the art will recognize, or be able to ascertain using no more than routine experimentation, many equivalents to the specific embodiments described herein. It is, therefore, to be understood that the foregoing embodiments are presented by way of example only and that, within the scope of the appended claims and equivalents thereto, inventive embodiments may be practiced otherwise than as specifically described. In addition, any combination of two or more features, systems, articles, materials, kits, and/or methods described herein, if such features, systems, articles, materials, kits, and/or methods are not mutually inconsistent, is included within the scope of the present disclosure.

## CLAIMS

1. An electrophoretic medium comprising a non-polar fluid and including:  
a first type of particle having a first optical property and a first charge polarity;  
a second type of particle having a second optical property, and having a second charge polarity with a first charge magnitude, the second particle having a surface coating of polymer that is covalently bound to the particle;  
a third type of particle having a third optical property, and having the second charge polarity with a second charge magnitude smaller than the first charge magnitude; and  
a fourth particle having a fourth optical property, and having the second charge polarity with a third charge magnitude larger than the first charge magnitude,  
wherein the third type of particle and the fourth type of particle both include a layer of polymer complexed to the particle.

2. An electrophoretic medium comprising a non-polar fluid and including:  
a first type of particle having a first optical property and a first charge polarity;  
a second type of particle having a second optical property, and having a second charge polarity with a first charge magnitude, the second particle having no surface coating of polymer;  
a third type of particle having a third optical property, and having the second charge polarity with a second charge magnitude smaller than the first charge magnitude; and  
a fourth particle having a fourth optical property, and having the second charge polarity with a third charge magnitude larger than the first charge magnitude,  
wherein the third type of particle and the fourth type of particle both include a layer of polymer complexed to the particle.

3. An electrophoretic medium comprising a non-polar fluid and including:  
a first type of particle having a first optical property and a first charge polarity;  
a second type of particle having a second optical property, and having a second charge polarity with a first charge magnitude, the second particle having greater than 200 mg of a charge control agent (CCA) adsorbed onto the second particle for each gram of second particle in the electrophoretic medium;  
a third type of particle having a third optical property, and having the second charge polarity with a second charge magnitude smaller than the first charge magnitude; and

a fourth particle having a fourth optical property, and having the second charge polarity with a third charge magnitude larger than the first charge magnitude,

wherein the third type of particle and the fourth type of particle each have less than 50 mg of a charge control agent (CCA) adsorbed onto the third and fourth particle for each respective gram of third and fourth particles in the electrophoretic medium.

4. The electrophoretic medium of claim 3, wherein the charge control agent comprises a quaternary amine head group and a fatty acid tail.

5. The electrophoretic medium of any of claims 1-4, wherein when the electrophoretic medium is disposed between two electrodes separated by 10-50  $\mu\text{m}$ , the first type of particle has a lower electrophoretic mobility when 20V is applied between the two electrodes than when 10V is applied between the electrodes.

6. The electrophoretic medium of any of claims 1-5, wherein the first particle is a light-scattering particle, and the second, third, and fourth particles are light-absorbing.

7. The electrophoretic medium of any of any of claims 1-6 wherein the first particle is white, and the second, third, and fourth particles are selected from cyan, magenta, and yellow.

8. The electrophoretic medium of claim 7, wherein the yellow, magenta and cyan pigments exhibit diffuse reflectances at 650, 550 and 450 nm, respectively, when the respective particles are approximately isotropically distributed at 15% by volume (volume particles to volume solution) in a non-polar fluid having a refractive index less than 1.55 to make a solution, and the solution is disposed in a layer of thickness of approximately 1  $\mu\text{m}$  over a black background.

9. The electrophoretic medium of any of claims 1-8, wherein the first charge polarity is negative and the second charge polarity is positive.

10. A color electrophoretic display comprising:  
a light-transmissive electrode at a viewing surface;

a backplane including an array of thin film transistors coupled to pixel electrodes; and an electrophoretic medium of any of claims 1-9 disposed between the light-transmissive electrode and the backplane.

11. An electronic book reader, portable computer, tablet computer, cellular telephone, smart card, sign, watch, shelf label or flash drive comprising a color electrophoretic display according to claim 10.



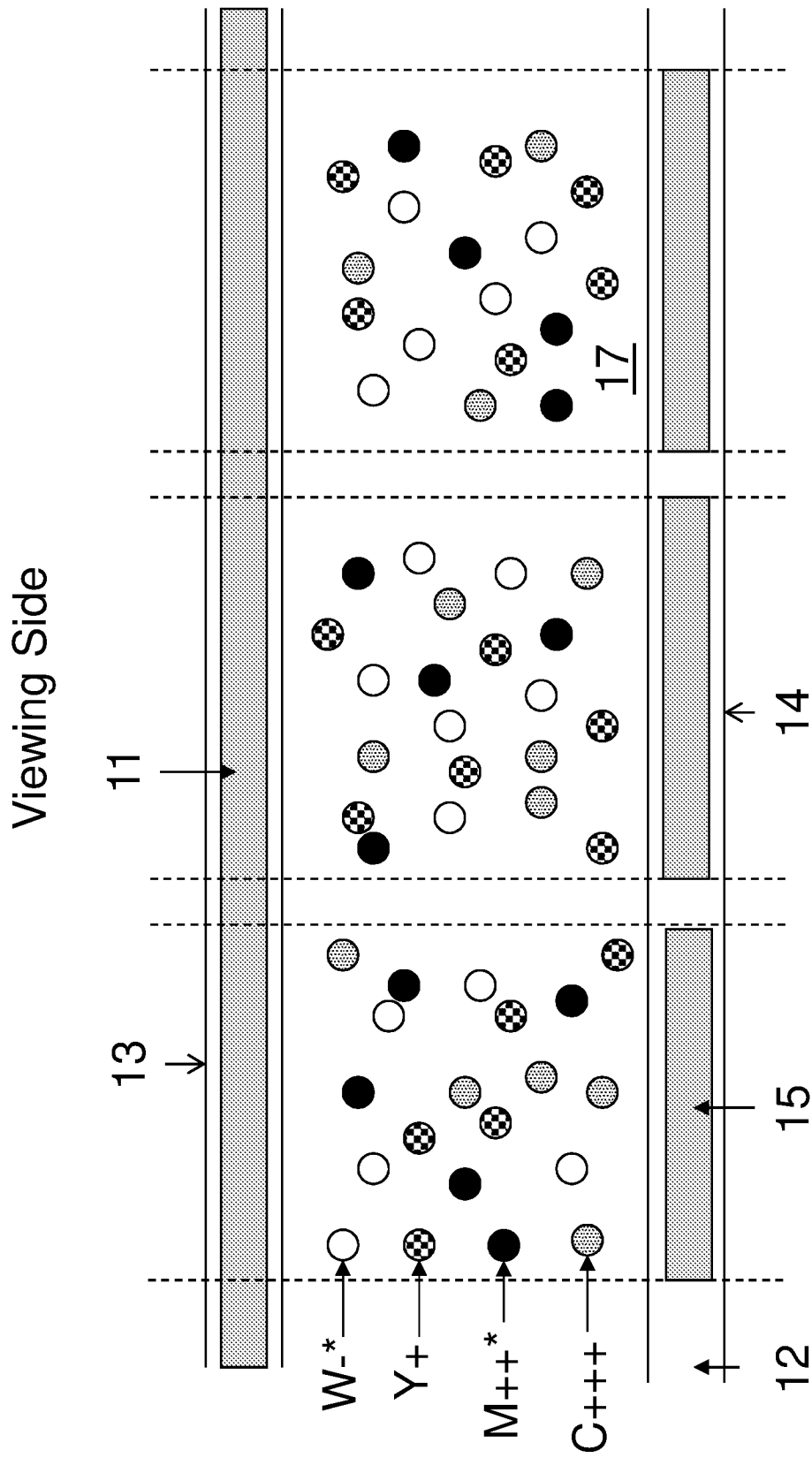

FIG. 2A

Viewing Side

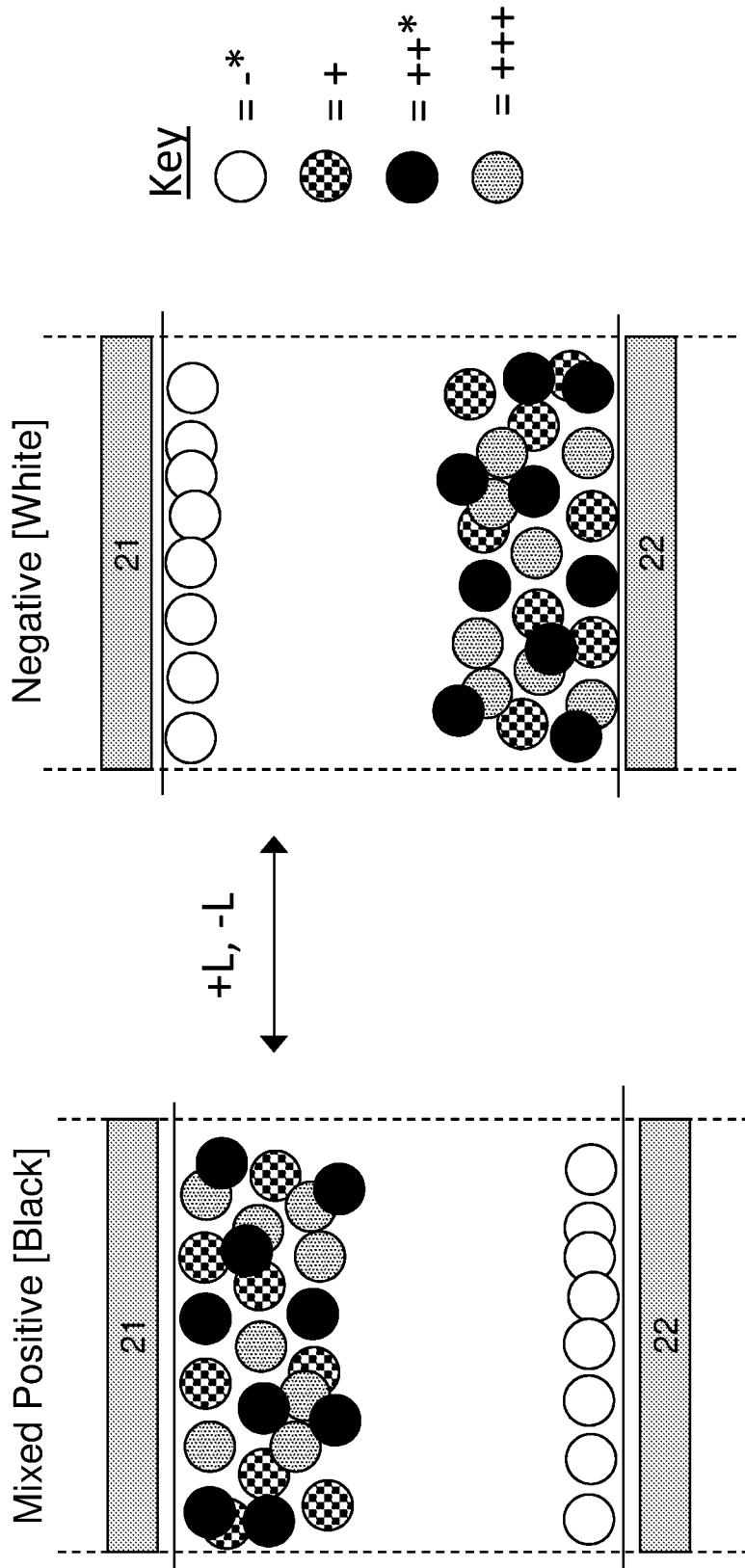

FIG. 2B

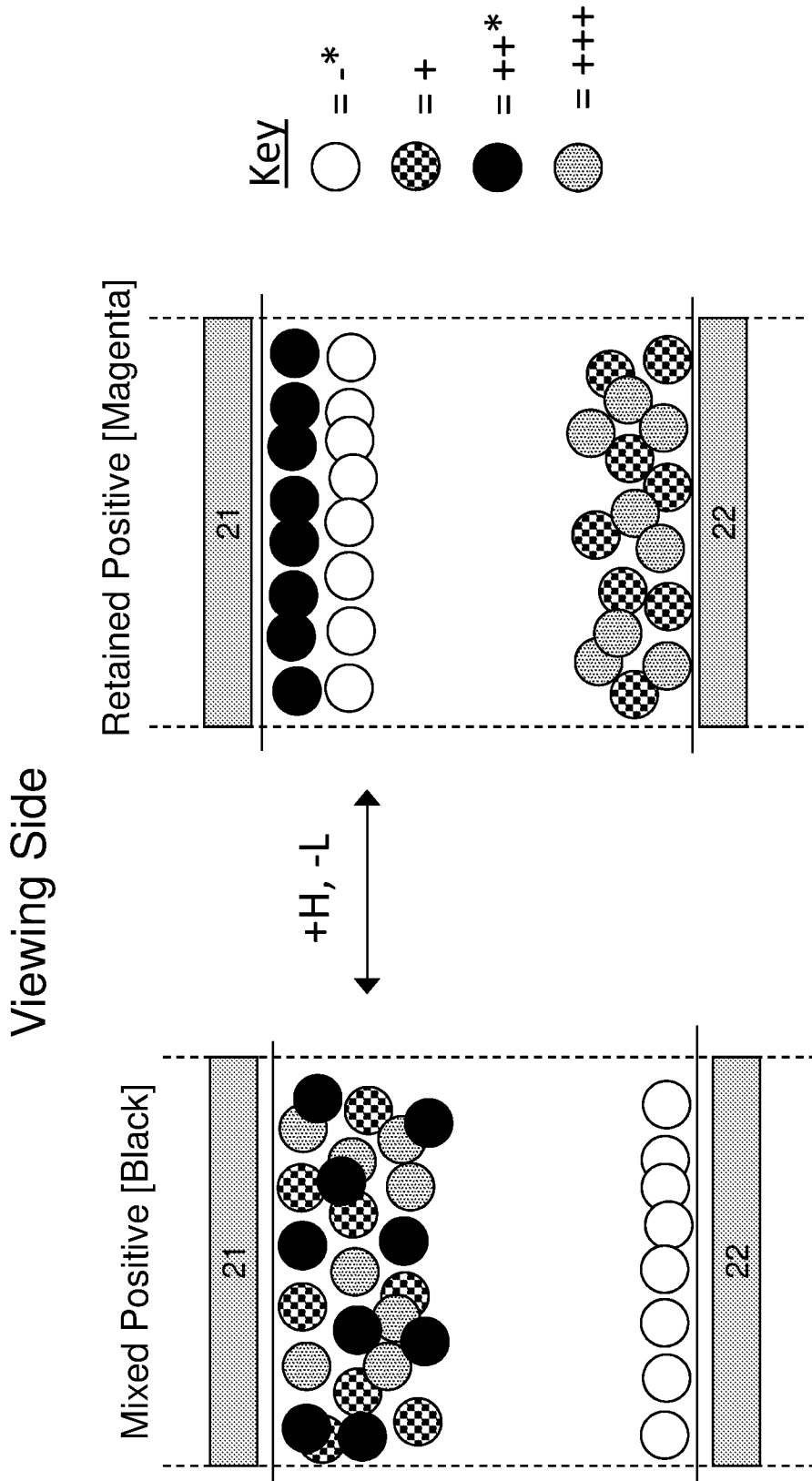

FIG. 2C

Viewing Side

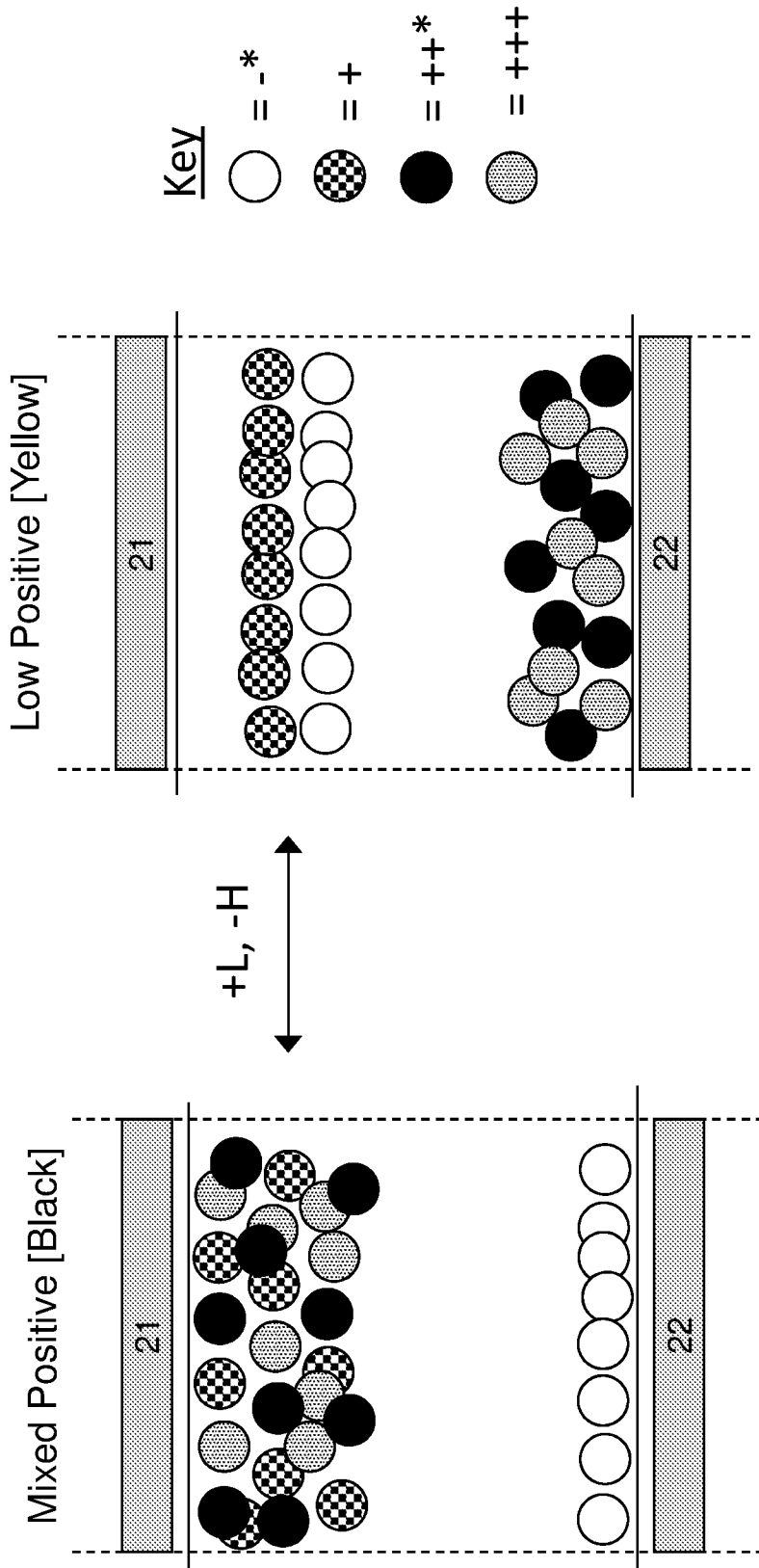

FIG. 2D

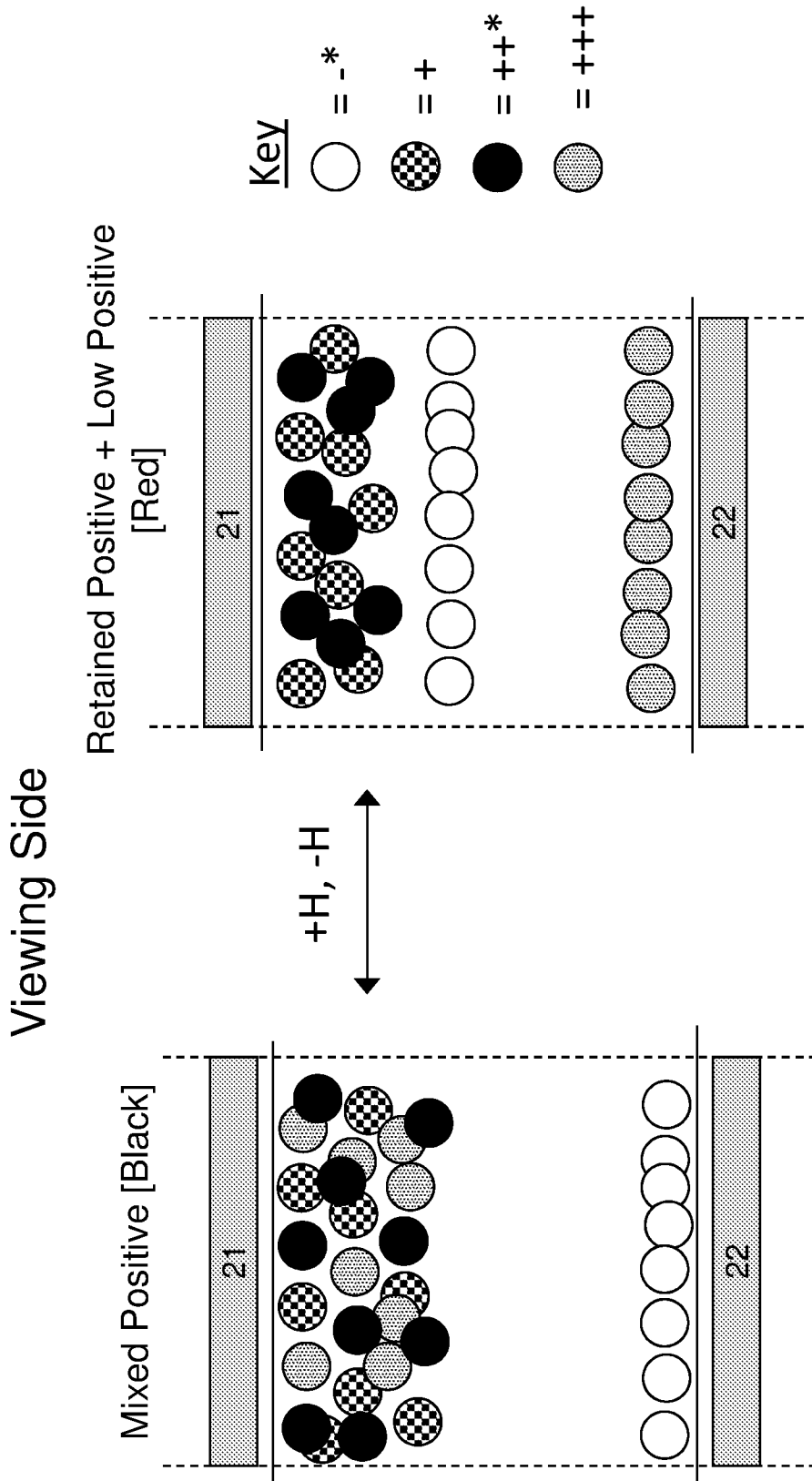

FIG. 2E

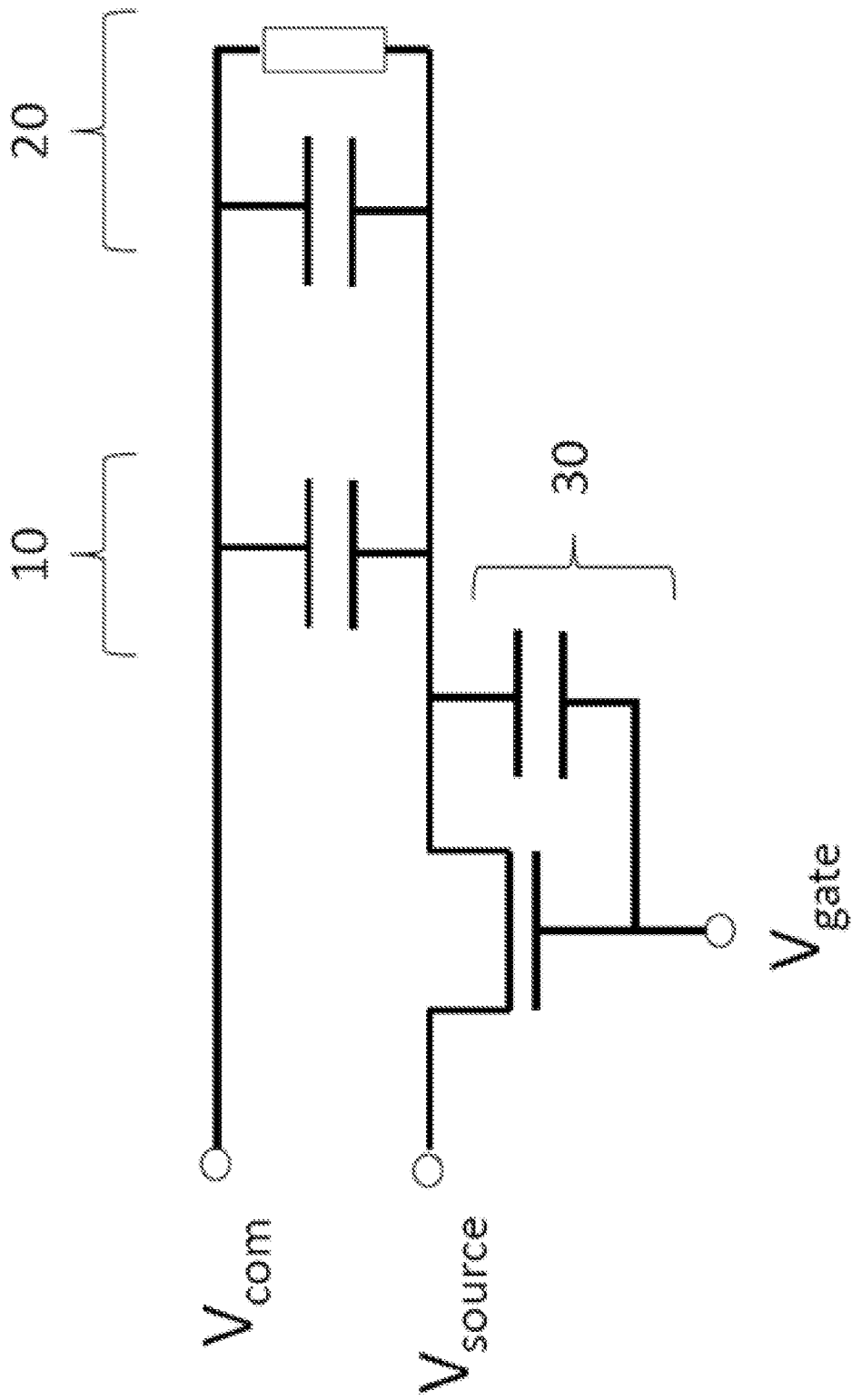

FIG. 3

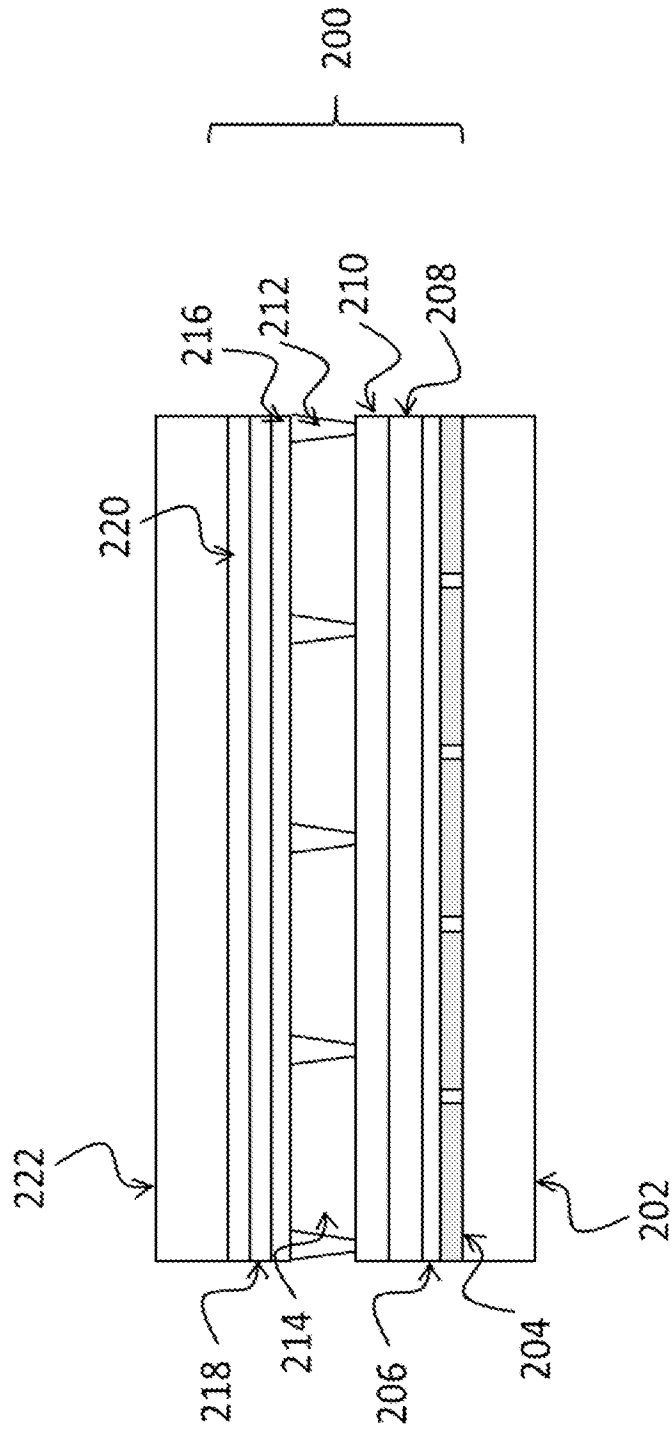

FIG. 4

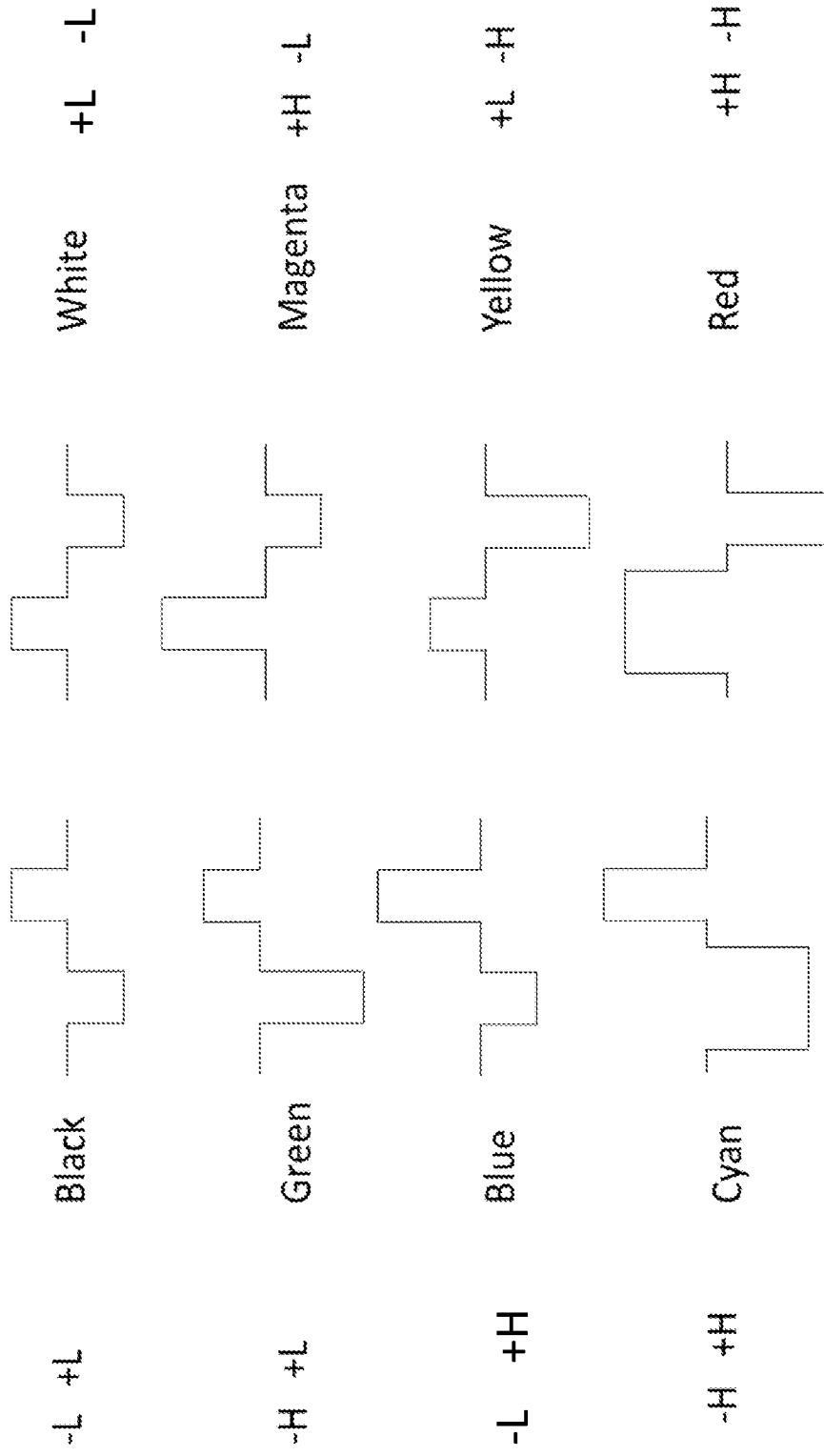

FIG. 5

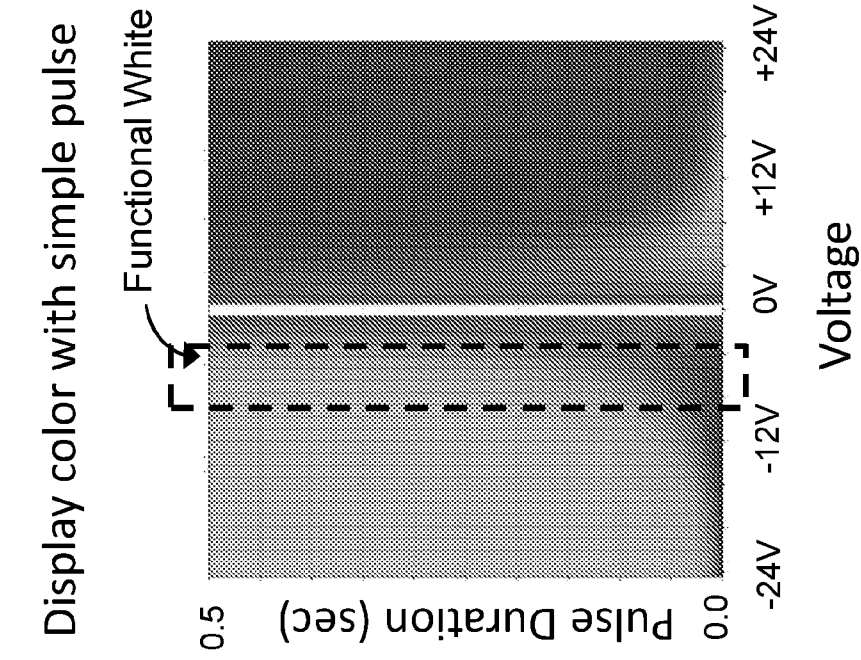

FIG. 6B

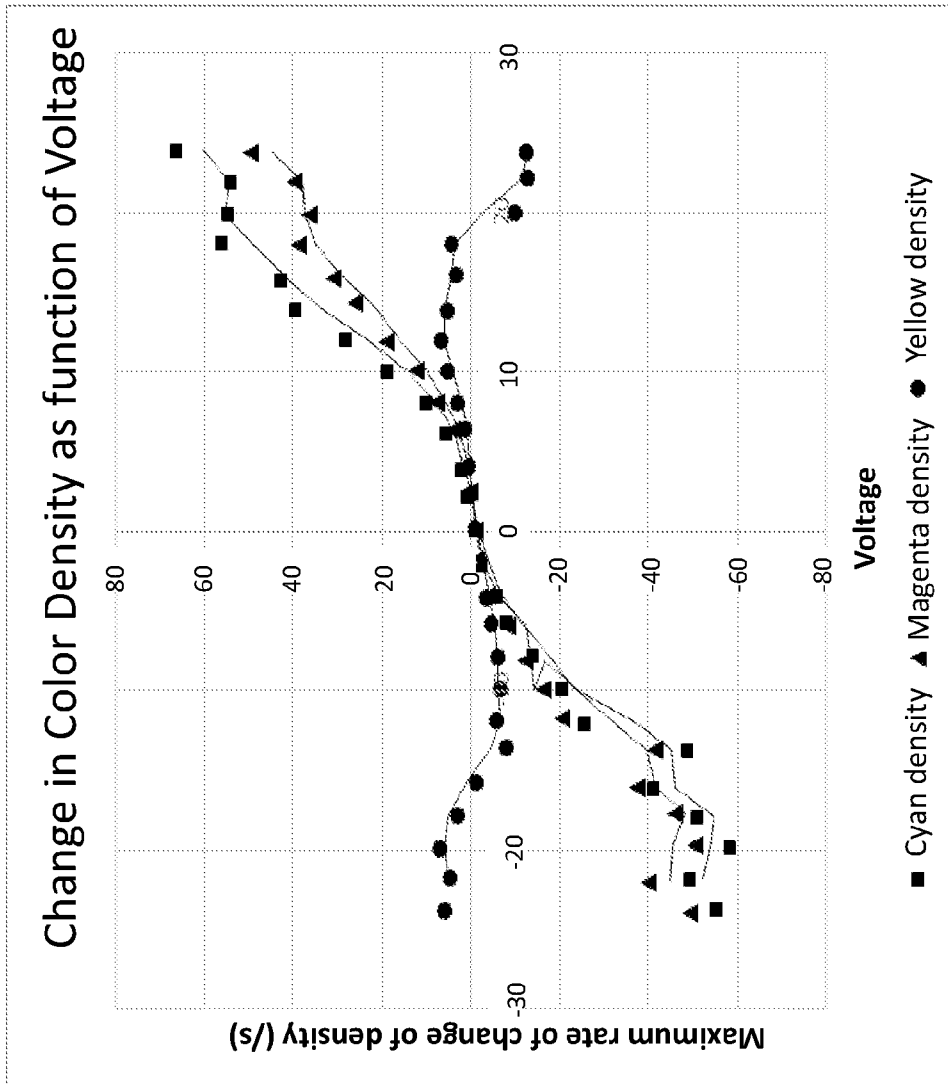

FIG. 6A

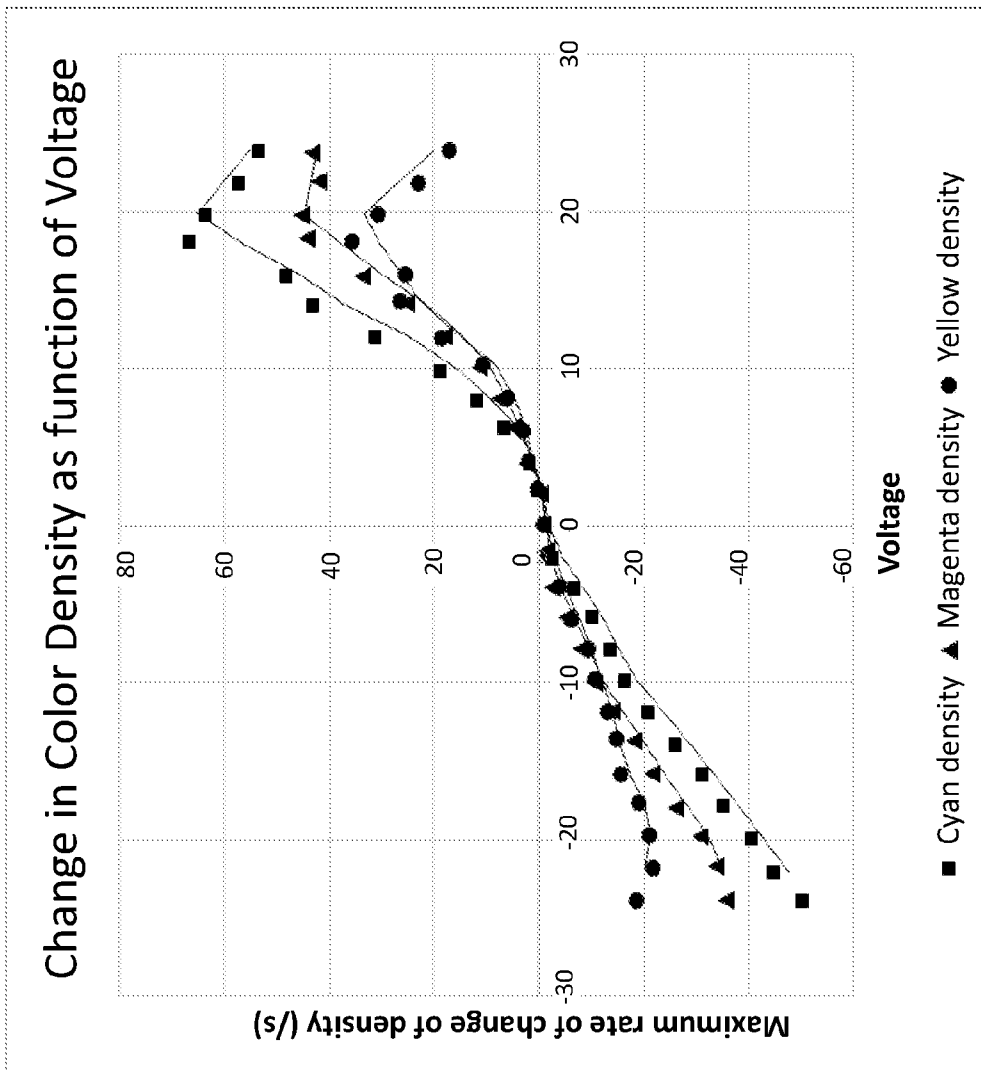

FIG. 7A

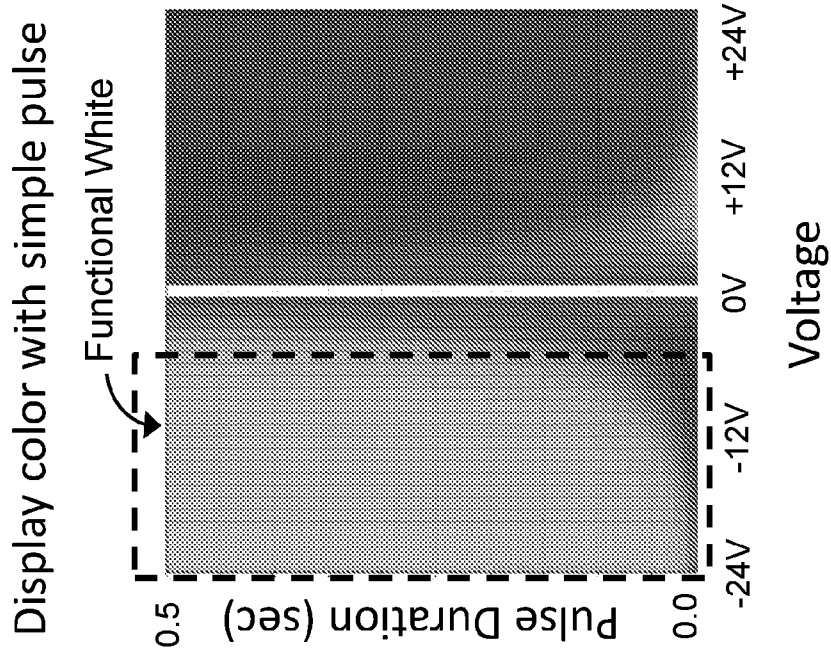

FIG. 7B

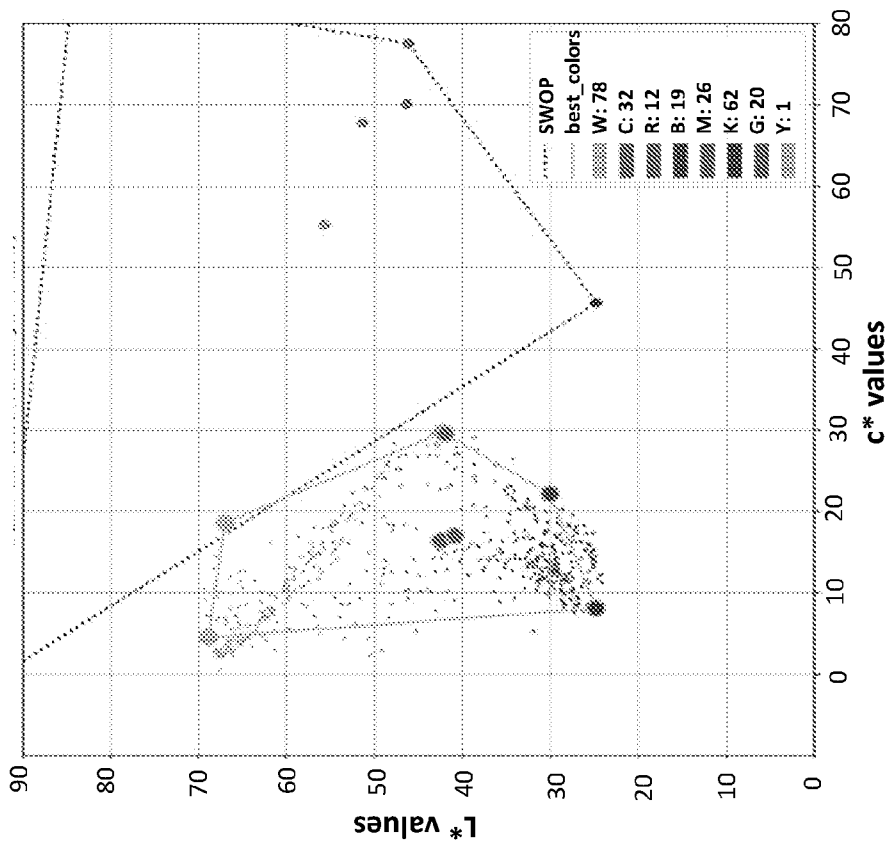
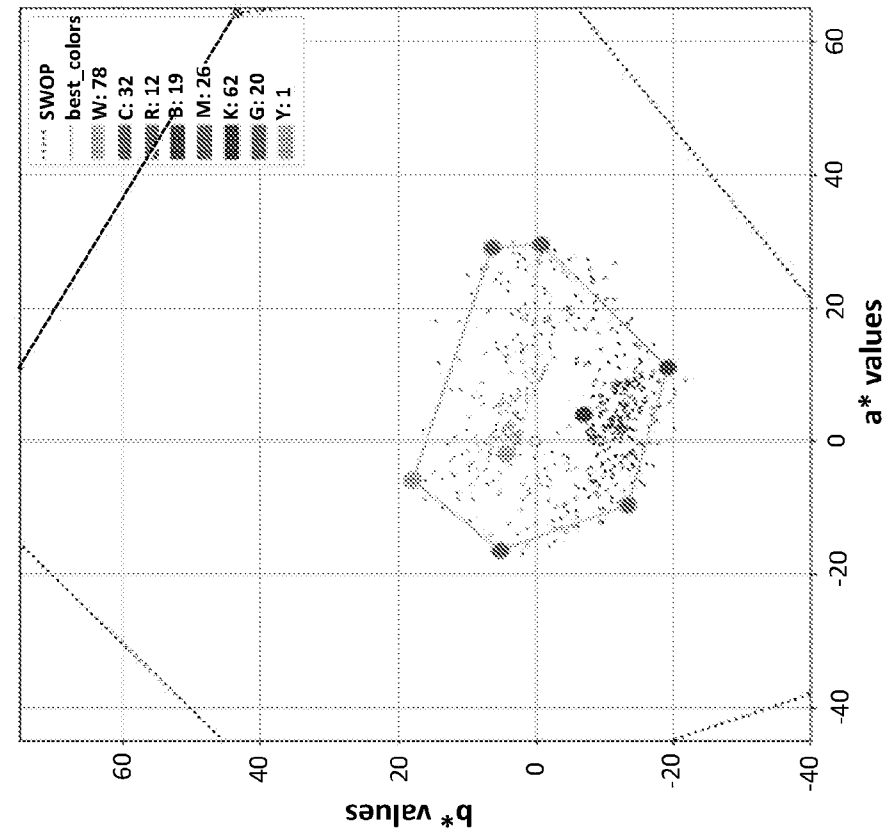

FIG. 8

## INTERNATIONAL SEARCH REPORT

International application No.

PCT/US2021/050237

**A. CLASSIFICATION OF SUBJECT MATTER**

G02F 1/167(2006.01)i; G02F 1/1676(2019.01)i; G02F 1/1675(2019.01)i

According to International Patent Classification (IPC) or to both national classification and IPC

**B. FIELDS SEARCHED**

Minimum documentation searched (classification system followed by classification symbols)

G02F 1/167(2006.01); G03G 9/06(2006.01); G09G 3/20(2006.01); G09G 3/34(2006.01)

Documentation searched other than minimum documentation to the extent that such documents are included in the fields searched

Korean utility models and applications for utility models  
Japanese utility models and applications for utility models

Electronic data base consulted during the international search (name of data base and, where practicable, search terms used)

eKOMPASS(KIPO internal) &amp; keywords: electrophoretic medium, particle, optical property, charge polarity, charge magnitude, surface coating, polymer, charge control agent, electrophoretic mobility

**C. DOCUMENTS CONSIDERED TO BE RELEVANT**

Category*	Citation of document, with indication, where appropriate, of the relevant passages	Relevant to claim No.
A	US 2014-0354615 A1 (MICHIAKI SAKAMOTO et al.) 04 December 2014 (2014-12-04) paragraphs [0064]-[0067]; and figures 1-2	1-11
A	US 2018-0136533 A1 (E INK CORPORATION) 17 May 2018 (2018-05-17) paragraphs [0102], [0113]-[0121]; claim 15; and figure 2	1-11
A	JP 2008-139803 A (FUJI XEROX CO., LTD.) 19 June 2008 (2008-06-19) paragraphs [0188]-[0208]; and figures 10-20	1-11
A	US 2014-0085706 A1 (ARKEMA FRANCE et al.) 27 March 2014 (2014-03-27) claims 1-4; and figure 1	1-11
A	KR 10-1687720 B1 (LG DISPLAY CO., LTD.) 29 December 2016 (2016-12-29) paragraphs [0037]-[0066]; and figures 2-4c	1-11

 Further documents are listed in the continuation of Box C. See patent family annex.

\* Special categories of cited documents:

“A” document defining the general state of the art which is not considered to be of particular relevance

“D” document cited by the applicant in the international application

“E” earlier application or patent but published on or after the international filing date

“L” document which may throw doubts on priority claim(s) or which is cited to establish the publication date of another citation or other special reason (as specified)

“O” document referring to an oral disclosure, use, exhibition or other means

“P” document published prior to the international filing date but later than the priority date claimed

“T” later document published after the international filing date or priority date and not in conflict with the application but cited to understand the principle or theory underlying the invention

“X” document of particular relevance; the claimed invention cannot be considered novel or cannot be considered to involve an inventive step when the document is taken alone

“Y” document of particular relevance; the claimed invention cannot be considered to involve an inventive step when the document is combined with one or more other such documents, such combination being obvious to a person skilled in the art

“&” document member of the same patent family

Date of the actual completion of the international search

23 December 2021

Date of mailing of the international search report

24 December 2021

Name and mailing address of the ISA/KR

**Korean Intellectual Property Office**  
**189 Cheongsa-ro, Seo-gu, Daejeon**  
**35208, Republic of Korea**

Facsimile No. +82-42-481-8578

Authorized officer

YANG, JEONG ROK

Telephone No. +82-42-481-5709

**INTERNATIONAL SEARCH REPORT**  
**Information on patent family members**

International application No.

**PCT/US2021/050237**

Patent document cited in search report			Publication date (day/month/year)	Patent family member(s)			Publication date (day/month/year)
US	2014-0354615	A1	04 December 2014	CN	104081270	A	01 October 2014
				CN	104081270	B	29 September 2017
				EP	2811338	A1	10 December 2014
				JP	5950213	B2	13 July 2016
				US	9541813	B2	10 January 2017
				WO	2013-114536	A1	08 August 2013
US	2018-0136533	A1	17 May 2018	CN	106687856	A	17 May 2017
				CN	106687856	B	13 December 2019
				CN	110824805	A	21 February 2020
				EP	3191892	A1	19 July 2017
				EP	3191892	A4	10 October 2018
				EP	3191892	B1	01 January 2020
				EP	3633662	A1	08 April 2020
				ES	2772138	T3	07 July 2020
				JP	2017-526980	A	14 September 2017
				JP	2018-077513	A	17 May 2018
				JP	6272623	B2	31 January 2018
				JP	6501862	B2	17 April 2019
				KR	10-1824723	B1	02 February 2018
				KR	10-2017-0033446	A	24 March 2017
				KR	10-2018-0014228	A	07 February 2018
				KR	10-2061435	B1	31 December 2019
				PL	3191892	T3	29 June 2020
				TW	201617711	A	16 May 2016
				TW	201730656	A	01 September 2017
				TW	201825996	A	16 July 2018
				TW	1591412	B	11 July 2017
				TW	1625584	B	01 June 2018
				TW	1646382	B	01 January 2019
				US	10509293	B2	17 December 2019
				US	10657869	B2	19 May 2020
				US	10678111	B2	09 June 2020
				US	2016-0085132	A1	24 March 2016
US	2017-0287377	A1	05 October 2017				
US	2018-0136534	A1	17 May 2018				
US	2020-0242993	A1	30 July 2020				
US	2020-0264488	A1	20 August 2020				
US	9921451	B2	20 March 2018				
WO	2016-040627	A1	17 March 2016				
JP	2008-139803	A	19 June 2008	JP	4049202	B1	20 February 2008
				US	2008-0112040	A1	15 May 2008
				US	7656576	B2	02 February 2010
US	2014-0085706	A1	27 March 2014	CN	104144791	A	12 November 2014
				EP	2678166	A1	01 January 2014
				FR	2981084	A1	12 April 2013
				FR	2981084	B1	27 March 2015
				JP	2015-530625	A	15 October 2015
				KR	10-2015-0067083	A	17 June 2015
				US	2014-0009818	A1	09 January 2014
				WO	2013-167814	A1	14 November 2013

**INTERNATIONAL SEARCH REPORT**  
**Information on patent family members**

International application No.

**PCT/US2021/050237**

Patent document cited in search report			Publication date (day/month/year)	Patent family member(s)			Publication date (day/month/year)
KR	10-1687720	B1	29 December 2016	CN	102338963	A	01 February 2012
				CN	102338963	B	22 July 2015
				KR	10-2012-0007387	A	20 January 2012
				TW	201202824	A	16 January 2012
				TW	1468832	B	11 January 2015
				US	2012-0013968	A1	19 January 2012
				US	8432606	B2	30 April 2013