

March 6, 1951

H. W. START ET AL

2,544,187

WELT TURNING MECHANISM FOR STRAIGHT BAR KNITTING MACHINES

Filed Dec. 11, 1946

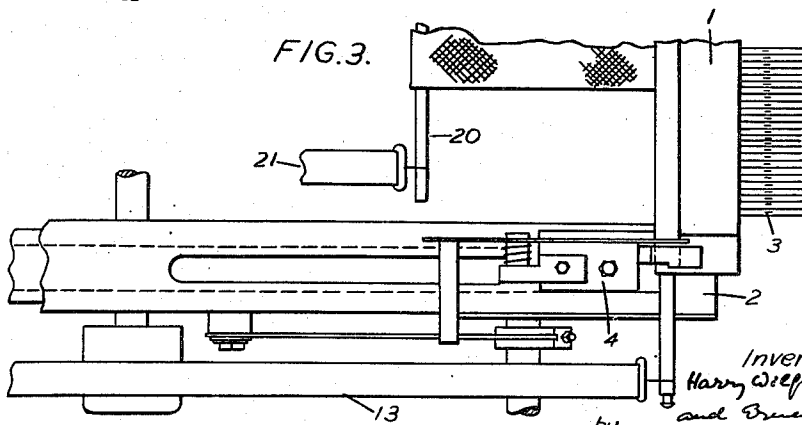
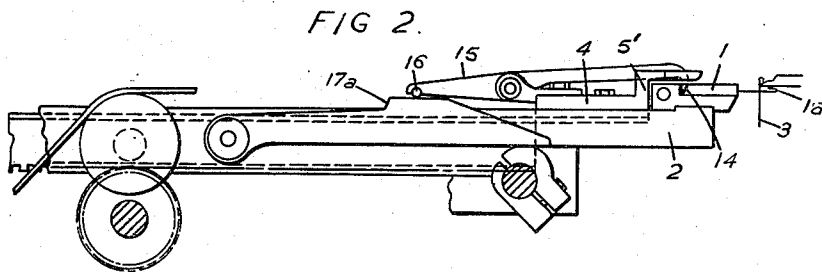
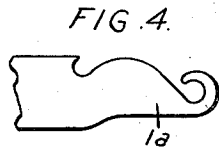
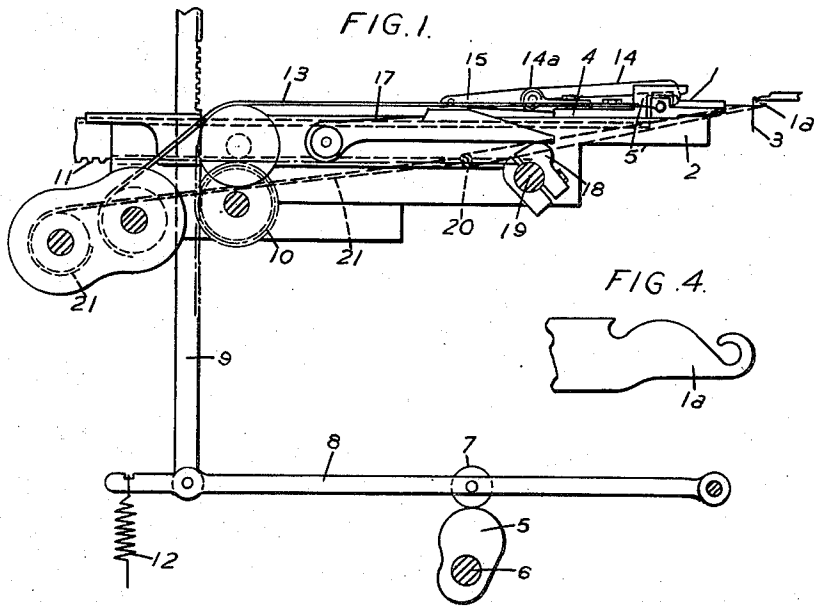

Inventors
Harry Wilfred Start
and Ernest Start
by
Michael S. [Signature]
Rising Agent

UNITED STATES PATENT OFFICE

2,544,187

WELT TURNING MECHANISM FOR STRAIGHT BAR KNITTING MA- CHINES

Harry Wilfred Start, Carlton, and Ernest Start,
Wilford, England, assignors to William Cotton
Limited, Loughborough, Leicestershire, Eng-
land

Application December 11, 1946, Serial No. 715,418
In Great Britain September 6, 1945

Section 1, Public Law 690, August 8, 1946
Patent expires September 6, 1965

7 Claims. (Cl. 66—96)

1

This invention relates to improvements in welt turning mechanism, for Cotton's patent and other straight bar knitting machines, of the kind in which welt hooks are mounted in a bar which is advanced towards the needles to receive in the welt hooks loops or kinks of an initial welt course, and is subsequently again advanced for the return to the needles, of the loops or kinks of the initial course, held by the welt hooks, in order to complete the welt. In one mechanism of this kind the welt bar is moved up to the needles by slides, having abutments thereon which engage with the welt bar when the slides are moved on horizontal bearers in the appropriate direction. The motion of the welt bar away from the needles during the knitting of the first part of the welt is effected by auxiliary take-up mechanism until such time as the welt wires can be inserted when the auxiliary tape-up is put out of action and the normal take-up mechanism, which is connected to the welt wires, is brought into action. When sufficient fabric has been knitted to form the welt the loops of the first course taken by the welt hooks are returned to the needles. For this purpose the welt hooks are moved into position over the needles and the latter may be raised up so as to pass through the loops or alternatively the loops may be taken by the picot points and restored by the points to the needles. In either case the welt hooks have to be disengaged from the loops and for this purpose the welt hooks have been provided with a raised part thereon, immediately behind the hook shaped ends of the welt hooks so that when the welt hooks are advanced towards the needles after the loops have been taken by the picot points or the needles, the bights of yarn on the welt hooks are raised to a higher level than the hook shaped ends of the welt hooks, to permit of the latter being withdrawn clear of the loops. To assist in the clearing of the loops from the welt hooks the picot points or needles are raised slightly as the welt hooks are withdrawn. The withdrawal of the welt hooks is effected by the auxiliary take-up mechanism and as this is only arranged to apply the necessary tension to the work for normal knitting the additional load imposed on it in withdrawing the welt hooks clear of the loops is more than the relatively light springs are capable of overcoming. In addition, the shape of the welt hooks used, as disclosed in British Patent No. 559,434, requires a sharp withdrawal motion, in order to give the loops an upward impetus to throw them clear

2

of the hooks as the latter are withdrawn. Occasionally it is possible that one or more loops near the selvedge may fail to cast off the hooks, and when this occurs one end of the welt bar is retained in its forward position near the needles, while the other end is drawn off by the normal take-up mechanism. In these circumstances, the bar becomes locked and damage to the needles as they rise up from the knock over position is liable to result. A sharp positive retraction of the welt bar clear off the needles would both prevent the bar becoming so locked and at the same time would break this occasional misplaced loop, so that no damage to the machine will arise.

The object of the present invention is to provide a quick withdrawal motion to the welt hooks at the appropriate time so that they can be withdrawn clear of the loops whilst the latter are raised above the tops of the hook shaped ends of the welt hooks.

The present invention provides welt-turning mechanism of the kind specified, having mechanism for advancing the welt-bar towards the needles to take the initial welt course and to restore it, means other than said mechanism for drawing the welt bar away from the needles during the knitting of at least the initial part of the welt, and means for imparting a quick retraction to the welt bar to disengage the welt hooks from the initial course after the latter has been returned to the needles. Preferably, the advancing mechanism is constructed and arranged to apply the quick retraction also. In order to permit of this, means may be provided for disconnecting the advancing and retracting mechanism from the welt bar during the knitting of the welt prior to the second advance of the welt bar.

The invention further provides welt turning mechanism of the kind specified having mechanism for advancing the welt bar towards the needles to take the initial welt course and to restore it and for effecting a rapid retraction of said bar to disengage the hooks from the said course on its restoration, means for disconnecting said mechanism from the welt bar when the hooks have taken said initial course, and means other than said mechanism for moving the welt bar away from the needles subsequent to said disconnection and during the knitting of at least a portion of the welt prior to the restoring advance by said mechanism.

In a preferred arrangement, the foregoing bar advancing and retracting mechanism incorpo-

3

rates bar-advancing means for advancing the bar towards the needles, which means is movable towards and away from the needles, a releasable coupling for connecting the bar to said means for rapid retraction by the latter, and means for causing said coupling to be disengaged during a movement of the bar-advancing means away from the needles immediately following the first advance thereof. In this case, the said advancing means may comprise at least one abutment movable towards and away from the needles which abutment is arranged to engage the retractable bar and thereby to advance it towards the needles but which is capable of retiring movement away from the bar when the latter is forward and the coupling is disengaged. The coupling may comprise at least one releasable catch for coupling the welt bar to the abutment to retire with the latter, and a relatively-stationary catch-release device movable into and out of operative position.

The invention further provides welt-turning mechanism of the kind specified, having mechanism for advancing the welt bar towards the needles, means operating through a portion of said mechanism for imparting a rapid retraction to the welt bar to disengage the welt hooks on the completion of the welt, and an auxiliary take-up for drawing the welt bar away from the needles during the knitting of at least a portion of the welt.

In order that the nature of this invention may be more readily understood, reference will now be made to the accompanying drawings in which:

Figure 1 is a sectional-elevation showing the welt hooks into a position to replace the loops on the needles, when a sufficient number of courses have been knitted to form the welt.

Figure 2 is an enlarged detail of part of Figure 1.

Figure 3 is a plan view of Fig. 2.

Figure 4 shows the head of one of the welt hooks.

In the drawing only part of the mechanism at one end of a needle bar is shown but it is to be understood that such mechanism is suitably coupled to the other end of each needle bar and the two mechanisms operate in unison. The welt hook bar 1 is mounted so that it can slide on a bracket 2 towards and away from the needles 3 and is moved up to the needles to take loops of the first course drawn on the needles in the welt hooks 1a and again to restore the loops taken by the welt hooks to the needles to complete the formation of the welt, by a slide 4 which is operated at the appropriate time by a cam 5 on the main shaft 6 of the machine engaging with a truck 7 on a pivoted arm 8 which is connected by rack 9 and pinion 10 to a rack 11 fixed to the slide 4. The truck 7 on the arm 8 is held in engagement with the cam by a spring 12. The slide 4 is formed with an abutment 5' which engages with the welt hook bar 1 and moves it towards the needles 3 when the slide 4 is moved in the appropriate direction. The slide 4 is operated to move the welt hooks 1 into position to receive the loops of the first course drawn on the needles and is then withdrawn to an inoperative position. During the knitting of at least a portion of the welt the welt hooks 1a are withdrawn from the needles 3 by the auxiliary take-up mechanism 13 provided for this purpose. When sufficient fabric has been knitted to form the welt the loops on the welt hooks are restored to the needles to complete the welt. For this purpose the welt hooks 1a are moved into position over

4

the needles 3 by the slide 4 and when the loops on the welt hooks have been engaged by the needles or by the picot points (when the latter are used to assist in the return of the loops to the needles) the welt hooks 1a are moved further in between the needles to raise the bights or yarn on the welt hooks above their hook shaped ends. The welt hooks are then withdrawn and in order to obtain a quick withdrawal action to the welt hooks whilst the loops are raised, the welt hook bar 1 is, during this motion, positively connected to the slide 4 so as to be withdrawn with the latter by means of the spring 12 previously described. The needles 3 or picot points as the case may be, may be raised slightly at the moment the welt hooks are withdrawn to assist in holding the loops clear of the welt hooks during the withdrawal motion.

In order to connect the welt hook bar 1 to the slide 4, a catch 14 is provided on the latter to engage with the welt hook bar 1. The catch 14 is pivoted to the slide 4 and is arranged so that it automatically engages with the welt hook bar 1 when the abutment 5' on the slide is in engagement therewith. For this purpose, the catch 14 may be formed with an extension 15 having a roller 16 which rides on the upper cam edge of an arm 17. This arm 17 has a steeply inclined part 17a on its upper edge in such a position relative to the needles that as the welt bar 1 approaches them the rod or roller 16 rides up the incline 17a causing the catch 14 to engage the welt bar. At the required time thereafter the truck 7 rapidly descends the flank of the cam 5 under the action of the spring 12 and the welt bar is thus withdrawn quickly by the catch 14. When the roller 16 reaches the incline again during the withdrawal of the welt bar, it rides down the incline and the catch is released. It will be understood that the catch 14 is only operative when the welt hooks 1a are being withdrawn at the completion of the welt and that provision must be made to hold it in an inoperative position when the slide 4 is operated at the commencement of the welt. To this end, the lower edge of arm 17 engages with a cam 18 mounted on a shaft 19 and the shaft 19 is angularly adjustable about its axis to move the cam 18 into and out of its operative position. When the cam 18 is in its operative position the arm 17 is raised thereby into a position whereat the roller 16 may be raised by the incline 17a and when the cam 18 is in its inoperative position the arm 17 is lowered to a position whereat the incline 17a is out of the path of the rod or roller 16 and the catch 14 is disengaged. Preferably the catch is biased into this position by a spring 14a and the rod or roller 16 rides on the bracket 2. The cam 18 may be mounted on the shaft 19 which carries the welt guides normally provided to engage with and hold the ends of the welt wires 20 during the production of the first part of the welt and until such time as the normal take-up mechanism 21 is brought into action. Provision may be made for automatically adjusting the shaft at the appropriate times to put the cam 18 into and out of action in well known manner from the pattern chain or control drum of the machine. Furthermore, since during the knitting of the welt it is necessary that the slide 4 shall not be continuously reciprocated but shall remain in a retracted position until it is required to advance the welt bar 1 at the completion of the welt, any suitable mechanism is provided under the control of said chain, drum, or their equivalent for

rendering the advancing cam 5 inoperative, for example by shogging truck 7 or by disengaging rack 9 from pinion 10.

We claim:

1. Welt turning mechanism including the combination, with means for supporting a plurality of needles, and a stationary support; of a welt bar slidably mounted on the stationary support and having a plurality of welt hooks adapted to cooperate with the needles; advancing and retracting means for moving the welt bar on said stationary support toward the needles for receiving loops or kinks of an initial welt course in the welt hooks and to return the initial course to the needles; auxiliary means for withdrawing the welt bar from said needles during the knitting of at least an initial part of the welt; and means for periodically imparting a quick retraction to said welt bar to disengage the welt hooks from the initial welt course when the latter has been returned to the needles.

2. Welt turning mechanism including the combination, with means for supporting a plurality of needles, and a stationary support; of a welt bar slidably mounted on the stationary support and having a plurality of welt hooks adapted to cooperate with the needles; advancing and retracting means for moving the welt bar on said stationary support toward the needles for receiving loops or kinks of an initial welt course in the welt hooks and to return the initial course to the needles; auxiliary means for withdrawing the welt bar from said needles during the knitting of at least an initial part of the welt; means for disconnecting the advancing and retracting means from the welt bar when the welt hooks have received the loops or kinks of said initial welt course; and means for periodically imparting a quick retraction to said welt bar to disengage the welt hooks from the initial welt course when the latter has been returned to the needles.

3. Welt turning mechanism including the combination, with means for supporting a plurality of needles, and a stationary support; of a welt bar slidably mounted on the stationary support and having a plurality of welt hooks adapted to cooperate with the needles; advancing and retracting means for moving the welt bar on said stationary support toward the needles for receiving loops or kinks of an initial welt course in the welt hooks and to return the initial course to the needles, comprising an abutment movable toward and away from the needles and capable of abutting the welt bar in retracted position of the latter to move the same toward said needles; a releasable coupling for connecting said welt bar to said abutment for rapid retraction or withdrawal by the latter; and means for releasing said coupling during withdrawal of said abutment away from said needles following initial advancement of said welt bar toward said needles by said abutment in order to allow the latter abutment to be withdrawn from said welt bar in stationary advanced position of the latter.

4. Welt turning mechanism including the combination, with means for supporting a plurality of needles, and a stationary support; of a welt bar slidably mounted on the stationary support and having a plurality of welt hooks adapted to cooperate with the needles; a movable abutment disposed in effective position to abut the welt bar and positively slide the latter toward the needles for receiving loops or kinks

of an initial welt course in the welt hooks thereof; a catch lever pivoted on the abutment so as to be movable therewith and having a forwardly extending hook or catch for engaging with said welt bar periodically to withdraw the latter away from said needles; means for moving said abutment toward and away from said needles; and means for periodically engaging with another portion of said catch lever and thereby effecting the periodical engagement of the hook thereof with, and disengagement of said hook from, said welt bar in advanced position of the latter to allow said abutment to be withdrawn from said welt bar while the latter remains in the advanced position.

5. Welt turning mechanism including the combination, with means for supporting a plurality of needles, and a stationary support; of a welt bar slidably mounted on the stationary support and having a plurality of welt hooks adapted to cooperate with the needles; a movable abutment disposed in effective position to abut the welt bar and positively slide the latter toward the needles for receiving loops or kinks of an initial welt course in the welt hooks thereof; a catch lever pivoted on the abutment so as to be movable therewith and having a forwardly extending hook or catch for engaging with said welt bar periodically to withdraw the latter away from said needles; a rotatable cam shaft carrying an eccentric cam; a rocking lever having a follower roller engaging upon the cam, a movable rack connected to said rocking lever to be moved thereby when the lever is rocked by said cam; a pinion rotatably mounted on said stationary support and meshing with said rack; a second rack meshing with said pinion and connected to said abutment for moving the latter by means of said cam; and means for periodically engaging with another portion of said catch lever and thereby effecting the periodical engagement of the hook thereof with, and disengagement of said hook from, said welt bar in advanced position of the latter to allow said abutment to be withdrawn from said welt bar while the latter remains in the advanced position.

6. Welt turning mechanism including the combination, with means for supporting a plurality of needles, and a stationary support; of a welt bar slidably mounted on the stationary support and having a plurality of welt hooks adapted to cooperate with the needles; a movable abutment disposed in effective position to abut the welt bar and positively slide the latter toward the needles for receiving loops or kinks of an initial welt course in the welt hooks thereof; a catch lever pivoted on the abutment so as to be movable therewith and having a forwardly extending hook or catch for engaging with said welt bar periodically to withdraw the latter away from said needles; means for moving said abutment toward and away from said needles; a rearwardly extending cam follower portion on the catch lever; a cam supporting shaft carrying an adjustable cam; and a cam supporting arm pivotally mounted on said stationary support in a position to rest on the latter cam and having an upper camming portion for slidably supporting the cam follower portion of said catch lever and thereby periodically engaging the hook thereof with and disconnecting said hook from said welt bar in predetermined position of the latter.

7. Welt turning mechanism including the combination, with means for supporting a plurality

7

of needles, and a stationary support; of a welt bar slidably mounted on the stationary support and having a plurality of welt hooks adapted to cooperate with the needles; a movable abutment disposed in effective position to abut the welt bar and positively slide the latter toward the needles for receiving loops or kinks of an initial welt course in the welt hooks thereof; a catch lever pivoted on the abutment so as to be movable therewith and having a forwardly extending hook or catch for engaging with said welt bar periodically to withdraw the latter away from said needles; means for moving said abutment toward and away from said needles; a rearwardly extending cam follower portion on the catch lever; a cam supporting shaft carrying an adjustable cam; a cam supporting arm pivotally mounted on said stationary support in a position to rest on the latter cam and having an upper camming portion for slidably supporting the cam follower portion of said catch lever and thereby periodically engaging the hook

8

thereof with and disconnecting said hook from said welt bar in predetermined position of the latter; and auxiliary means for periodically withdrawing said welt bar with its welt hooks from said needles.

HARRY WILFRED START.
ERNEST START.

REFERENCES CITED

10 The following references are of record in the file of this patent:

UNITED STATES PATENTS

| | Number | Name | Date |
|----|-----------|-----------------------|---------------|
| 15 | 2,295,512 | Bitzer ----- | Sept. 8, 1942 |
| | 2,303,412 | Wachtler et al. ----- | Dec. 1, 1942 |
| | 2,371,932 | Start et al. ----- | Mar. 20, 1945 |
| | 2,431,160 | Bitzer ----- | Nov. 18, 1947 |

FOREIGN PATENTS

| | Number | Country | Date |
|----|---------|---------------------|---------------|
| 20 | 537,336 | Great Britain ----- | June 18, 1941 |