



HU000027404T2

(19) **HU**(11) Lajstromszám: **E 027 404**(13) **T2****MAGYARORSZÁG**  
Szellemi Tulajdon Nemzeti Hivatala**EURÓPAI SZABADALOM**  
**SZÖVEGÉNEK FORDÍTÁSA**(21) Magyar ügyszám: **E 11 728929**(51) Int. Cl.: **E04C 5/12** (2006.01)(22) A bejelentés napja: **2011. 04. 15.**

(86) A nemzetközi (PCT) bejelentési szám:

**PCT/IB 11/001047**

(96) Az európai bejelentés bejelentési száma:

**EP 20110728929**

(87) A nemzetközi közzétételi szám:

**WO 12140463**

(97) Az európai bejelentés közzétételi adatai:

**EP 2697446 A1** **2012. 10. 18.**

(97) Az európai szabadalom megadásának meghirdetési adatai:

**EP 2697446 B1** **2016. 02. 24.**

(72) Feltaláló(k):  
**STUBLER, Jérôme, F-75016 Paris (FR)**  
**SYLVESTRE, Aurélien, F-92130 Issy Les Moulineaux (FR)**  
**JOYE, Stéphane, F-92100 Boulogne-Billancourt (FR)**  
**MELLIER, Erik, F-78000 Versailles (FR)**

(73) Jogosult(ak):  
**SOLETANCHE FREYSSINET, 92500 Rueil Malmaison (FR)**

(74) Képviselő:  
**SBGK Szabadalmi Ügyvivői Iroda, Budapest**

(54)

**Rögzítő szerelvény**

Az európai szabadalom ellen, megadásának az Európai Szabadalmi Közlönyben való meghirdetésétől számított kilenc hónapon belül, felszólalást lehet benyújtani az Európai Szabadalmi Hivatalnál. (Európai Szabadalmi Egyezmény 99. cikk(1))

A fordítást a szabadalmas az 1995. évi XXXIII. törvény 84/H. §-a szerint nyújtotta be. A fordítás tartalmi helyességét a Szellemi Tulajdon Nemzeti Hivatala nem vizsgálta.



(11) **EP 2 697 446 B1**

(12) **EUROPEAN PATENT SPECIFICATION**

(45) Date of publication and mention  
of the grant of the patent:  
**24.02.2016 Bulletin 2016/08**

(21) Application number: **11728929.8**

(22) Date of filing: **15.04.2011**

(51) Int Cl.:  
**E04C 5/12 (2006.01)**

(86) International application number:  
**PCT/IB2011/001047**

(87) International publication number:  
**WO 2012/140463 (18.10.2012 Gazette 2012/42)**

(54) **ANCHORING ASSEMBLY**  
VERANKERUNGSANORDNUNG  
ENSEMBLE D'ANCRAGE

(84) Designated Contracting States:  
**AL AT BE BG CH CY CZ DE DK EE ES FI FR GB  
GR HR HU IE IS IT LI LT LU LV MC MK MT NL NO  
PL PT RO RS SE SI SK SM TR**

(43) Date of publication of application:  
**19.02.2014 Bulletin 2014/08**

(73) Proprietor: **SOLETANCHE FREYSSINET**  
**92500 Rueil Malmaison (FR)**

(72) Inventors:  
• **STUBLER, Jérôme**  
**F-75016 Paris (FR)**  
• **SYLVESTRE, Aurélien**  
**F-92130 Issy Les Moulineaux (FR)**

• **JOYE, Stéphane**  
**F-92100 Boulogne-Billancourt (FR)**  
• **MELLIER, Erik**  
**F-78000 Versailles (FR)**

(74) Representative: **Cabinet Plasseraud**  
**66, rue de la Chaussée d'Antin**  
**75440 Paris Cedex 09 (FR)**

(56) References cited:  
**EP-A1- 0 323 285 DE-U1- 20 311 950**  
**FR-A1- 2 492 870 FR-A1- 2 822 177**  
**GB-A- 2 155 973**

**EP 2 697 446 B1**

Note: Within nine months of the publication of the mention of the grant of the European patent in the European Patent Bulletin, any person may give notice to the European Patent Office of opposition to that patent, in accordance with the Implementing Regulations. Notice of opposition shall not be deemed to have been filed until the opposition fee has been paid. (Art. 99(1) European Patent Convention).

## Description

### BACKGROUND OF THE INVENTION

**[0001]** The present invention relates to structural cables used in construction works. It applies, in particular, to the anchoring of stay cables or pre-stressing cables.

**[0002]** Such structural cables are frequently made of a plurality of parallel tendons. Their ends are anchored using blocks in which channels are formed for receiving and blocking individually the tendons, for example by means of split conical jaws.

**[0003]** The tendons of the cable are made of metal, for example in the form of strands. In the main part of the cable, they are often contained in individual sheaths of plastic material which isolate them from the environment and thus protect them from corrosive agents. In order to firmly hold a tendon in the anchor block, its plastic sheath is removed in the anchoring region. It is then necessary to provide particular anti-corrosion protection measures in the anchoring region. In general, the volume containing the exposed portions of the tendons is filled with a protective material injected under pressure into the anchoring region:

**[0004]** The injection step must be carried out with caution so as to avoid any remaining voids in the volume to be filled, since such voids may be the starting point of the corrosion phenomenon for the metal of the tendons, in particular if water leaks in.

**[0005]** Wax is an interesting example of protective material to be injected in the anchoring region, in view of its properties of adherence, corrosion protection and fatigue behavior. The wax is in a solid state at room temperature and becomes liquid when heated. It can thus form a reversible filling, which is useful for allowing inspection of the anchorage.

**[0006]** Other injectable protective materials can be used, in particular thick materials, e.g. grease, or hardening materials, e.g. a resin or a polymer.

**[0007]** For a given construction work, the protective material is selected by taking into account the required functionalities for installing and or maintaining the anchorage.

**[0008]** The volume to be filled with protective material includes a chamber located on the front side of the anchorage and closed by a cover. The end portions of the tendons of the cable, protruding from the anchorage, are located in that chamber.

**[0009]** In certain anchorage designs (see, e.g., WO 01/20098 A1), there is a second chamber at the rear of the anchor block, in which the ends of the individual sheaths of the tendons are located. The rear face of that second chamber is closed by a sealing device, of the stuffing box type or the like, through which the sheathed parts of the tendons extend. The filling of the second chamber with the protective material can be carried out separately from the filling of the first chamber located on the front side of the anchorage, or simultaneously. In the

latter case, one or more communication channels are generally provided through the anchor block, in addition to the channels containing the tendons, to allow the injected material to flow.

**[0010]** In other kinds of anchorage design (see, e.g., EP 0 896 108 A2 or EP 1 227 200 A1), the rear side of the anchor block does not have a second chamber containing the tendons collectively. The ends of the individual sheaths of the tendons are located in the channels of the anchor block, or in extensions of those channels provided on the rear side of the anchor block.

**[0011]** The injection is performed once the tendons have been installed and tensioned. Conventionally, the filling material is injected by an inlet located in a low portion of the anchorage until it flows out by a vent located in a high portion of the anchorage. This minimizes the risk of leaving voids in the volume to be filled.

**[0012]** FR 2 492 870 A1 discloses an anchoring assembly according to the preamble of claim 1.

**[0013]** An object of the invention is to make it possible to further optimize the performance of the anchorage in view of the functionalities which may be required in different situations.

**[0014]** The invention solves this problem by an anchoring assembly according to claim 1.

**[0015]** If there are more than one chamber, e.g. a chamber at the front and a chamber at the rear of the anchor block, they may contain different protective filler materials to optimize the behavior of the anchorage. In this case, at least one of the filler materials present in the chambers is different from the one put in the channels of the anchor block. It is also possible to have the same filler material in both chambers, provided that it is different from the one protecting the bare tendons and the blocking members in at least a few channels of the anchor block.

**[0016]** In an embodiment of the anchoring device, the first protective material is a wax or grease.

**[0017]** In an embodiment, there is no chamber on the rear side of the anchor block, and the second protective material is a wax or grease. In this case, the first protective material may be a polymer or a resin.

**[0018]** Alternatively, the anchoring device may comprise a first chamber on the rear side of the anchor block, containing tensioned portions of the plurality of tendons of the cable, and a second chamber on the front side of the anchor block, containing the end portions of the plurality of tendons of the cable, both SUMMARY OF THE INVENTION the first and second chambers containing protective material.

**[0019]** The protective material of the first chamber can be different from the protective material of the second chamber. For example, the protective material of the first chamber can be a polymer or a resin, while the protective material of the second chamber can be a wax or grease.

**[0020]** In an embodiment of the anchoring device, the chamber has two parts on the front and rear sides of the anchor block, respectively, connected together by at least one communication channel extending through the

anchor block and filled with the second protective material. Typically, the communication channel of the anchor block has no tendon of the cable extending therethrough.

**[0021]** Other features and advantages of the method and apparatus disclosed herein will become apparent from the following description of non-limiting embodiments, with reference to the appended drawings.

#### BRIEF DESCRIPTION THE DRAWINGS

##### **[0022]**

Figure 1 is a schematic view of an exemplary anchoring device for a structural cable, in a first injection phase;

Figures 2-4 are schematic views of the anchoring device of figure 1, in other phases of an installation method; and

Figure 5 is a schematic view of another embodiment of the anchoring device.

#### DESCRIPTION OF EMBODIMENTS

**[0023]** The structural cable shown in figure 1 is made of a plurality of tendons 10 each consisting of a metallic strand 11 contained in an individual plastic sheath 12. Only two tendons 10 are shown in the figures for simplicity of the drawing. Typically, a higher number of tendons, e.g. a few tens of tendons, are used. The tendons 10 extend parallel to each other along the prescribed path of the structural cable, e.g. along the inclined path of a stay cable between the deck and a pylon of a bridge, or along the path specified for a pre-stressing cable.

**[0024]** The structural cable is anchored at both ends. The anchoring devices transfer the tensile load of the cable to the structure.

**[0025]** In order to firmly grip the tendons 10 in the anchoring devices, the plastic sheaths 12 are removed at the ends of the tendons 10, thus exposing the metal of the strands 11. At each end of the cable, the bare parts of the tendons 10 extend through and beyond an anchor block 15 of the anchoring device. The anchor block 15 has a number of channels 16 extending between its rear side 17 (towards the running part of the cable where the tendons will be under tension) and its front side 18. Each tendon 10 is received within one of the channels 16 with a blocking member 19.

**[0026]** In the illustrated embodiment, each channel 16 designed to receive a tendon 10 has a cylindrical part near the rear side 17 of the anchor block 15, with a diameter slightly larger than that of the strand 11, extended by a conical part which tapers outwardly towards the front side 18 of the anchor block 15. The blocking member is in the form of a conical jaw 19 placed in the conical part of the channel 16 to grip the metallic strand 11. The jaw 19 has a cylindrical axial bore for receiving the strand,

and is made of a plurality of sectors (e.g. three sectors) held together by a ring 20 inserted in an annular groove located near the wide end of the jaw 19.

**[0027]** To install the cable, its tendons 10 are inserted into their respective channels 16 with the conical jaws 19, the tensile force is applied by holding the strands 11 in their parts projecting from the front face 18 of the anchor block 15, pulling them using an actuator such as a hydraulic jack, and pushing the jaws 19 into the channels 16. When the actuator is deactivated, the jaws 19 block the strands 11 in their channels 16. This tensioning operation can be performed strand by strand, group of strands by group of strands, or collectively for the whole cable.

**[0028]** After the cable has been tensioned, there remain some intervals in the channels 16, in particular around the strands 11 in their cylindrical parts and between the jaw sectors in their conical parts.

**[0029]** A first injection phase is carried out to make sure that these intervals are filled with a substance 100 which will protect the metal from corrosion.

**[0030]** In an embodiment, the substance with which the channels 16 are filled in the first injection phase is a wax or grease. However, it may also be a curing material such as a polymer or a resin.

**[0031]** As shown in figure 1, the first injection phase can be performed for each channel 16 by using a bell-shaped cover 25 over the inlet of the channel. The cover 25 is sealingly applied against the front side 18 of the anchor block 15 using a gasket 26, and its opposite end has an aperture providing a passage for the strand 11. A sealing ring 27 is placed around the strand 11 to seal the front end of the cover 25 which is secured in its position by a ring 28 clamped on the free end of the strand 11.

**[0032]** The protective material 100 is injected in a fluid or soft phase through an inlet 29 provided in the cover 25. Since the volume of the intervals not occupied by the metallic strand and jaw is known with precision, a regulated amount of protective material can be injected into each channel 16 to ensure complete filling of the channel. An injection pump (not shown) is controlled to inject the set amount of protective material 100 inside the cover 25 to completely fill the channel 16.

**[0033]** The attachment of the bell-shaped cover 25 to the strand 11 ensures that the cover 25 is kept in place at the inlet of the channel 16 while the protective material is injected under pressure to overcome the head loss within the channel 16. It will be noted that other mechanisms can be used to hold the cover in that step, for example attached to the anchor block 15.

**[0034]** The filling material 100 injected into the channels 16 is allowed to cure (if it is a polymer or resin) or to solidify by cooling (if it is a wax) and the cover 25 is removed from the front side of the anchor block 15. If the filling 100 is a thick material such as grease, no hardening time is needed and the cover may be removed just after the injection. An amount of protective material 100 may

or may not remain on the portion of the strand 11 which was contained in the cover 25.

**[0035]** After the first injection phase, a second injection phase is carried out to fill the other closed volume(s) of the anchorage with protective material. In the embodiment illustrated by figures 1-4, there are two chambers to be filled, one 30 on the rear side of the anchor block 15 and one 31 on the front side. These two chambers 30, 31 are filled separately with protective material 200, 300.

**[0036]** The first chamber 30 on the rear side 17 of the anchor block is delimited radially by a tube 32 through which the tensioned parts of the tendons 10 extend. The ends of the plastic sheaths 12 of the tendons are located within the chamber 30. Opposite the anchor block 15, the chamber 30 is closed by a sealing device 34, for example a stuffing box arrangement as described in WO 01/20098 A1, which isolates the chamber 30 from the outside while leaving passages for the tendons 10.

**[0037]** In this example, the front end of the tube 32 has a flange 33 which forms a bearing surface for the anchor block 15, the flange 33 being applied against the structure equipped with the cable. It will be appreciated that the anchorage may have various other arrangements within the scope of the present invention.

**[0038]** The injection of the protective material 200 into the first chamber 30 (figure 2) is performed through an inlet which, in the illustrated example, is formed by an opening 35 provided in the anchor block 15, in a low part of the chamber 30. In the illustrated structure, the opening 35 is bent to be accessible on a lateral side of the anchor block 15. It may also be straight and accessible on the front side 18 of the anchor block 15. A vent 36 is formed in an upper part of the tube 32 to evacuate the air contained in the chamber 30 during the injection step. Once the injection is complete, the vent 36 is closed by a plug 37 (figure 3) and the protective material 200 is allowed to harden or solidify, if needed, prior to closing the inlet opening 35 with another plug 38.

**[0039]** The second chamber 31 on the front side 18 of the anchor block is delimited by a case 40 shown in figure 4. The case 40 is mounted on the anchor block 15 by means of bolts or other fixing means (not shown). A sealing ring 41 is provided between the rear end of the case 40 and the front face 18 of the anchor block to prevent the protective material from leaking when injected. The case 40 is dimensioned to contain the bare ends of all the tendons 10 of the cable. Its lower part has an opening 42 for injecting the protective material 300 and its upper part has a vent 43 for evacuating the air when the protective material 300 is injected.

**[0040]** The protective material 300 injected into the second chamber 31 fills all the remaining voids. When it flows out through the vent 43, the injection is stopped and a plug 45 is placed on the vent 43. The injected protective material 300 is allowed to harden or solidify, if needed, prior to closing the inlet opening 42 with another plug.

**[0041]** The protective material injected to fill (i) the

channels 16, (ii) the chamber 30 at the rear of the anchor block 15 and (iii) the chamber 31 at the front of the anchor block 15 can be selected independently for each volume to be filled, thus permitting an optimization of the anchorage by choosing each material for its properties as desired.

**[0042]** The chamber 31 located at the front of the anchor block 15 may be opened, by removing the case 40, during the lifetime of the anchorage to enable checking of its proper operation. For this reason, it is typically desirable to use in that chamber 31 a protective material 300 which can be easily removed. A wax is an advantageous material for this purpose since it can be melted or at least softened by heating and pumped out. Grease can also be used.

**[0043]** The gripping and anchoring of the tendons 10 takes place in the channels 16. A flexible material 100 having lubricating properties, such as grease or wax, is suitable in view of its good fatigue behavior which enhances the ultimate strength of the tendons.

**[0044]** The chamber 30 at the rear of the anchor block 15 is potentially exposed to infiltrations of water flowing along the structure or the cable. A flexible, sticky and coherent material 200 is often a good choice to best prevent such infiltrations. A polymer or a resin is advantageously injected in that part of the anchorage.

**[0045]** Figure 5 illustrates an alternative embodiment of an anchoring device, for which the second injection phase, i.e. after filling of the channels 16 where the tendons are blocked, is essentially performed in one step. The chamber thus filled is made of two parts 50, 51 connected together by one or more communication channels 52. The first part 50 is located on the rear side 17 of the anchor block 15 and is functionally similar to the first chamber 30 of the embodiment shown in figures 1-4, being delimited by a cylindrical tube 32 and a stuffing box-type of sealing device 34. The second part 51 is located on the front side 18 of the anchor block 15 and is functionally similar to the second chamber 31 of the embodiment shown in figures 1-4, being delimited by a case 40. The communication channels 52 do not contain tendons and extend through the anchor block 15 parallel to the channels 16 containing the tendons.

**[0046]** After installation and tensioning of the tendons 10, the first injection phase is performed to fill the channels 16 with a protective substance 100 as described with reference to figure 1. Then the case 40 is assembled on the anchor block 15 and the second injection phase is performed to inject a protective material 400 in the two-part chamber 50-51.

**[0047]** The example of figure 5 is, for example, that of the anchorage of the lower end of an inclined stay cable. In this configuration the lower part of the anchorage is in the lower part of the case an inlet 42 is provided. As in the previous embodiment, two vents 36, 43 are provided, one (36) in the upper part of the rear part 50 of the chamber and the other (43) in the upper part of the front part 51 of the chamber. During the second injection phase,

the level of the fluid material 400 rises. When it reaches the vent 43, it overflows and a plug 45 is put on that vent 43 to continue the injection, thus permitting the protective material 400 to rise further through the communication channels 52 and into the rear part 50 of the chamber. When the other vent 36 is reached, the second injection phase is over and a plug is put on the vent 36. The protective material 400 is allowed to harden or solidify, if needed, prior to closing the inlet opening 42 with another plug.

**[0048]** In the embodiment of figure 5, the protective material 400 injected into the chamber 50-51 in the second phase is not the same as the protective material 100 injected into the channels 16 in the first phase.

**[0049]** In yet another embodiment, the chamber filled in the second injection phase is located only on the front side of the anchor block 15. The plastic sheaths 12 of the tendons 10 then have their end sections inside the channels 16 of the anchor block 15 or in individual extensions of those channels behind the anchor block 15.

**[0050]** In this case, the first injection phase is performed to fill the channels 16 and/or their extensions with the protective material 100. The filling is made at least in the parts of the channels 16 and/or their extensions where the metal of the strand is free of plastic sheath. The separate injection of the protective material into the channels 16 and/or their extensions ensures a reliable filling irrespective of the variable head losses typically experienced by the injected substance in those channels.

**[0051]** Afterwards, the second injection phase is carried out to introduce the protective material 300, which is different from the previously injected protective material 100, into the chamber 31 located only on the front side 18 of the anchor block 15 and containing the end portions of the strands 11. This can be performed in the same manner as described with reference to figure 4.

**[0052]** In the case where the chamber 31 to be filled with protective material is located only on the front side of the anchor block 15, wax or grease will often be a suitable choice for the protective material both in the channels 16 and in the chamber 31 because of its good fatigue properties (for the channels 16) and because it is relatively easy to remove (for the chamber 31). However, other choices may be suitable or preferable. For instance, water-tightness at the rear of the channels in such an anchorage design can be a concern. For this reason, an adhering filler material such as a polymer or a resin may be used in the channels 16, while a wax or grease is injected into the chamber 31.

**[0053]** The above-described method of protecting the bare ends of the tendons of a structural cable using two or more injection phases in different parts of the anchoring device is applicable to the installation of a new cable. It is also applicable to the maintenance or repair of an existing cable. In this case, the protective filler material which was previously located in the different parts of the anchoring device may be removed (for example using a method as described in French patent application No. 11

52557 filed on March 28, 2011) prior to injecting one or more new protective material(s) in two or more phases as described above.

**[0054]** While a detailed description of exemplary embodiments of the invention has been given above, various alternatives, modifications, and equivalents will be apparent to those skilled in the art.

**[0055]** In particular, it will be appreciated that the above-mentioned choices for the protective materials with which the different parts of the anchorage are filled is a matter of design optimization, and may be changed depending on the functionalities desired for a specific anchorage design having a specific geometrical configuration or disposition.

**[0056]** The anchoring device having different filler materials to protect the tendons in different parts may be installed by using the above-described two-phase injection method. However, other installation methods can also be contemplated to obtain the hybrid filling of the anchoring device, i.e. with different protective materials in different parts.

## Claims

1. An anchoring assembly comprising a cable made of plurality of tendons (10) and an anchoring device for said cable made of plurality of tendons (10), the anchoring device comprising:
  - an anchor block (15) having a front side (18), a rear side (17) and channels (16,52) extending between the front and rear sides, each tendon of the cable being received in a respective channel with a blocking member (19);
  - a first protective material (100) contained in at least some of the channels (16) of the anchor block, each of said channels receiving one of said tendons;
  - a chamber (31, 50-51) containing end portions of the plurality of tendons of the cable, located on at least the front side of the anchor block; **characterised in that** said anchoring device further comprises
  - a second protective material (300; 400), different from the first protective material, contained in and filling said chamber and being in contact with the end portions of the plurality of tendons (10) of the cable.
2. The anchoring assembly as claimed in claim 1, wherein the first protective material (100) is a wax or grease.
3. The anchoring assembly as claimed in claim 1 or 2, wherein there is no chamber on the rear side of the anchor block (15), and wherein the second protective material is wax or grease.

4. The anchoring assembly as claimed in claim 3, wherein the first protective material is a polymer or a resin.
5. The anchoring assembly as claimed in claim 1 or 2, wherein the anchoring device comprises a first chamber (30) on the rear side (17) of the anchor block (15), containing tensioned portions of the plurality of tendons (10) of the cable, and a second chamber (31) on the front side (18) of the anchor block, containing said end portions of the plurality of tendons of the cable, wherein the first and second chambers (30, 31) both contain protective material.
6. The anchoring assembly as claimed in claim 5, wherein the protective material (200) of the first chamber (30) is different from the protective material (300) of the second chamber (31).
7. The anchoring assembly as claimed in claim 5 or 6, wherein the protective material (200) of the first chamber (30) is a polymer or a resin.
8. The anchoring assembly as claimed in any one of claims 5 to 7, wherein the protective material (300) of the second chamber (31) is a wax or grease.
9. The anchoring assembly as claimed in claim 1 or 2, wherein the chamber has two parts (50-51) on the front and rear sides of the anchor block (15), respectively, connected together by at least one communication channel (52) extending through the anchor block and filled with the second protective material (400).
10. The anchoring assembly as claimed in claim 9, wherein the communication channel (52) of the anchor block (15) has no tendon of the cable extending therethrough.

#### Patentansprüche

1. Verankerungsanordnung, die ein Kabel, das aus mehreren Spannkabeln (10) hergestellt ist, und eine Verankerungsvorrichtung für das aus mehreren Spannkabeln (10) hergestellte Kabel aufweist, wobei die Verankerungsvorrichtung aufweist:
- einen Ankerblock (15) mit einer Vorderseite (18), einer Rückseite (17) und Kanälen (16, 52), die sich zwischen den Vorder- und Rückseiten erstrecken, wobei jedes Spannkabel des Kabels in einem jeweiligen Kanal mit einem Sperrelement (19) aufgenommen ist;
  - ein erstes Schutzmaterial (100), das in wenigstens einigen der Kanäle (16) des Ankerblocks enthalten ist, wobei jeder der Kanäle eins der

Spannkabel aufnimmt;  
 - eine Kammer (31, 50 - 51), die Endabschnitte der mehreren Spannkabel des Kabels enthält, die wenigstens auf der Vorderseite des Ankerblocks angeordnet ist;

**dadurch gekennzeichnet, dass** die Verankerungsvorrichtung ferner aufweist:

- ein zweites Schutzmaterial (300; 400), das sich von dem ersten Schutzmaterial unterscheidet, das in der Kammer enthalten ist und sie füllt und in Kontakt mit den Endabschnitten der mehreren Spannkabel (10) des Kabels ist.

2. Verankerungsanordnung nach Anspruch 1, wobei das erste Schutzmaterial (100) ein Wachs oder Schmierfett ist.
3. Verankerungsanordnung nach Anspruch 1 oder 2, wobei es keine Kammer auf der Rückseite des Ankerblocks (15) gibt und wobei das zweite Schutzmaterial Wachs oder Schmierfett ist.
4. Verankerungsanordnung nach Anspruch 3, wobei das erste Schutzmaterial ein Polymer oder Harz ist.
5. Verankerungsanordnung nach Anspruch 1 oder 2, wobei die Verankerungsvorrichtung eine erste Kammer (30) auf der Rückseite (17) des Ankerblocks (15), die gespannte Abschnitte der mehreren Spannkabel (10) des Kabels enthält, und eine zweite Kammer (31) auf der Vorderseite (18) des Ankerblocks, die die Endabschnitte der mehreren Spannkabel des Kabels enthält, aufweist, wobei die erste und zweite Kammer (30, 31) beide Schutzmaterial enthalten.
6. Verankerungsanordnung nach Anspruch 5, wobei das Schutzmaterial (200) der ersten Kammer (30) sich von dem Schutzmaterial (300) der zweiten Kammer (31) unterscheidet.
7. Verankerungsanordnung nach Anspruch 5 oder 6, wobei das Schutzmaterial (200) der ersten Kammer (30) ein Polymer oder ein Harz ist.
8. Verankerungsanordnung nach einem der Ansprüche 5 bis 7, wobei das Schutzmaterial (300) der zweiten Kammer (31) ein Wachs oder Schmierfett ist.
9. Verankerungsanordnung nach Anspruch 1 oder 2, wobei die Kammer jeweils zwei Teile (50 - 51) auf den Vorder- und Rückseiten des Ankerblocks (15) hat, die durch wenigstens einen Verbindungskanal (52) miteinander verbunden sind, der sich durch den Ankerblock erstreckt und mit dem zweiten Schutzmaterial (400) gefüllt ist.

10. Verankerungsanordnung nach Anspruch 9, wobei der Verbindungskanal (52) des Ankerblocks (15) kein Spannkabel des Kabels hat, das sich durch ihn erstreckt.

### Revendications

1. Ensemble d'ancrage comprenant un câble composé d'une pluralité de tendons (10) et d'un dispositif d'ancrage pour ledit câble composé d'une pluralité de tendons (10), le dispositif d'ancrage comprenant :

- un bloc d'ancrage (15) comportant un côté avant (18), un côté arrière (17) et des canaux (16, 52) s'étendant entre les côtés avant et arrière, chaque tendon du câble étant reçu dans un canal respectif avec un élément de blocage (19) ;
- un premier matériau de protection (100) contenu dans au moins certains des canaux (16) du bloc d'ancrage, chacun desdits canaux recevant l'un desdits tendons ;
- une chambre (31, 50-51) contenant des parties d'extrémité de la pluralité de tendons du câble, se trouvant sur au moins le côté avant du bloc d'ancrage ; **caractérisé en ce que** ledit dispositif d'ancrage comprend en outre
- un second matériau de protection (300 ; 400), différent du premier matériau de protection, contenu dans et remplissant ladite chambre et étant en contact avec les parties d'extrémité de la pluralité de tendons (10) du câble.

2. Ensemble d'ancrage selon la revendication 1, dans lequel le premier matériau de protection (100) est une cire ou de la graisse.

3. Ensemble d'ancrage selon la revendication 1 ou 2, dans lequel il n'y a pas de chambre sur le côté arrière du bloc d'ancrage (15), et dans lequel le second matériau de protection est de la cire ou de la graisse.

4. Ensemble d'ancrage selon la revendication 3, dans lequel le premier matériau de protection est un polymère ou une résine.

5. Ensemble d'ancrage selon la revendication 1 ou 2, dans lequel le dispositif d'ancrage comprend une première chambre (30) sur le côté arrière (17) du bloc d'ancrage (15), contenant des parties tendues de la pluralité de tendons (10) du câble, et une seconde chambre (31) sur le côté avant (18) du bloc d'ancrage, contenant lesdites parties d'extrémité de la pluralité de tendons du câble, dans lequel les première et seconde chambres (30, 31) contiennent toutes les deux un matériau de protection.

6. Ensemble d'ancrage selon la revendication 5, dans lequel le matériau de protection (200) de la première chambre (30) est différent du matériau de protection (300) de la seconde chambre (31).

7. Ensemble d'ancrage selon la revendication 5 ou 6, dans lequel le matériau de protection (200) de la première chambre (30) est un polymère ou une résine.

8. Ensemble d'ancrage selon l'une quelconque des revendications 5 à 7, dans lequel le matériau de protection (300) de la seconde chambre (31) est une cire ou de la graisse.

9. Ensemble d'ancrage selon la revendication 1 ou 2, dans lequel la chambre possède deux parties (50-51) sur les côtés avant et arrière du bloc d'ancrage (15), respectivement, reliées ensemble par au moins un canal de communication (52) s'étendant à travers le bloc d'ancrage et remplies du second matériau de protection (400).

10. Ensemble d'ancrage selon la revendication 9, dans lequel le canal de communication (52) du bloc d'ancrage (15) n'a aucun tendon du câble s'étendant à travers lui.

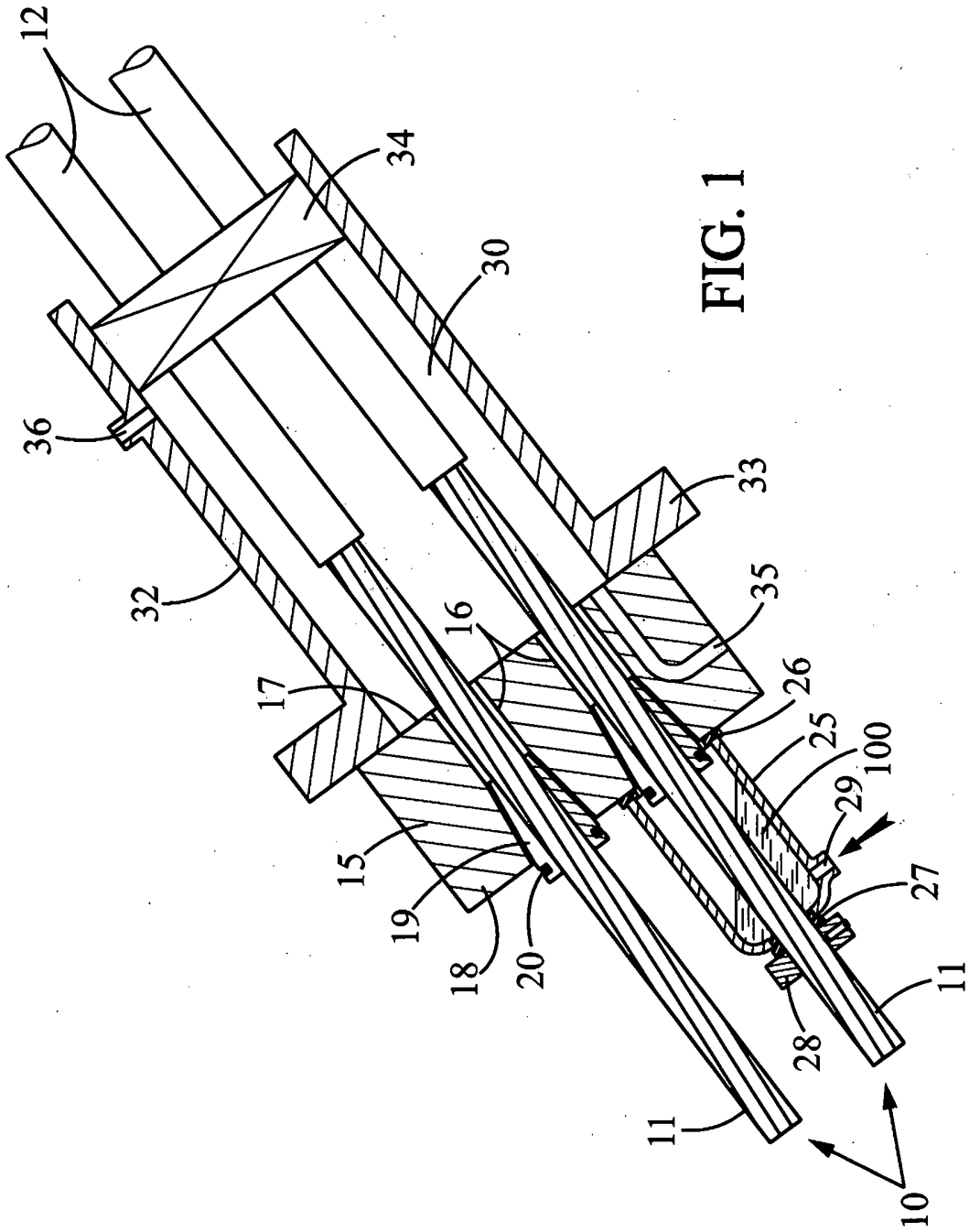

FIG. 1

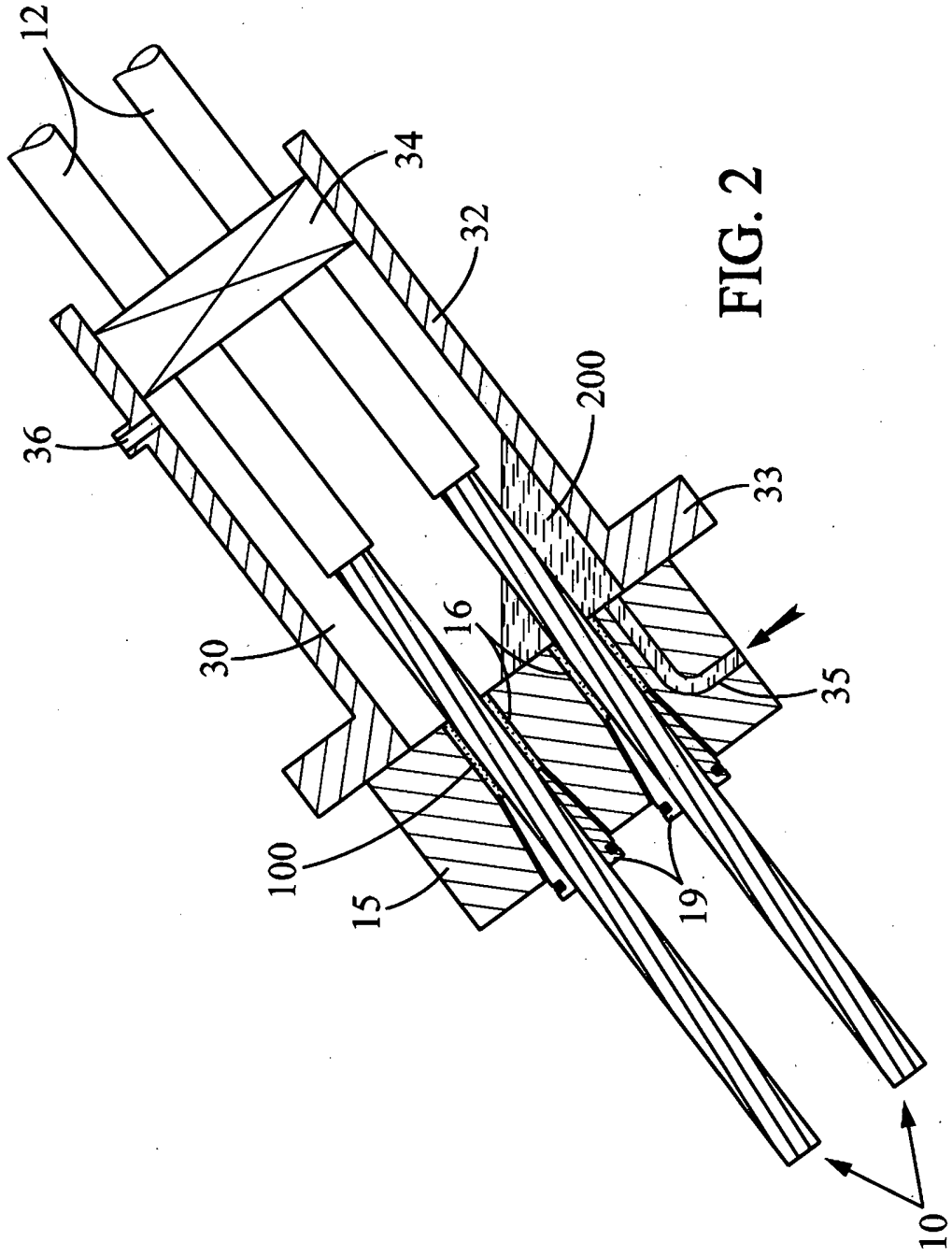
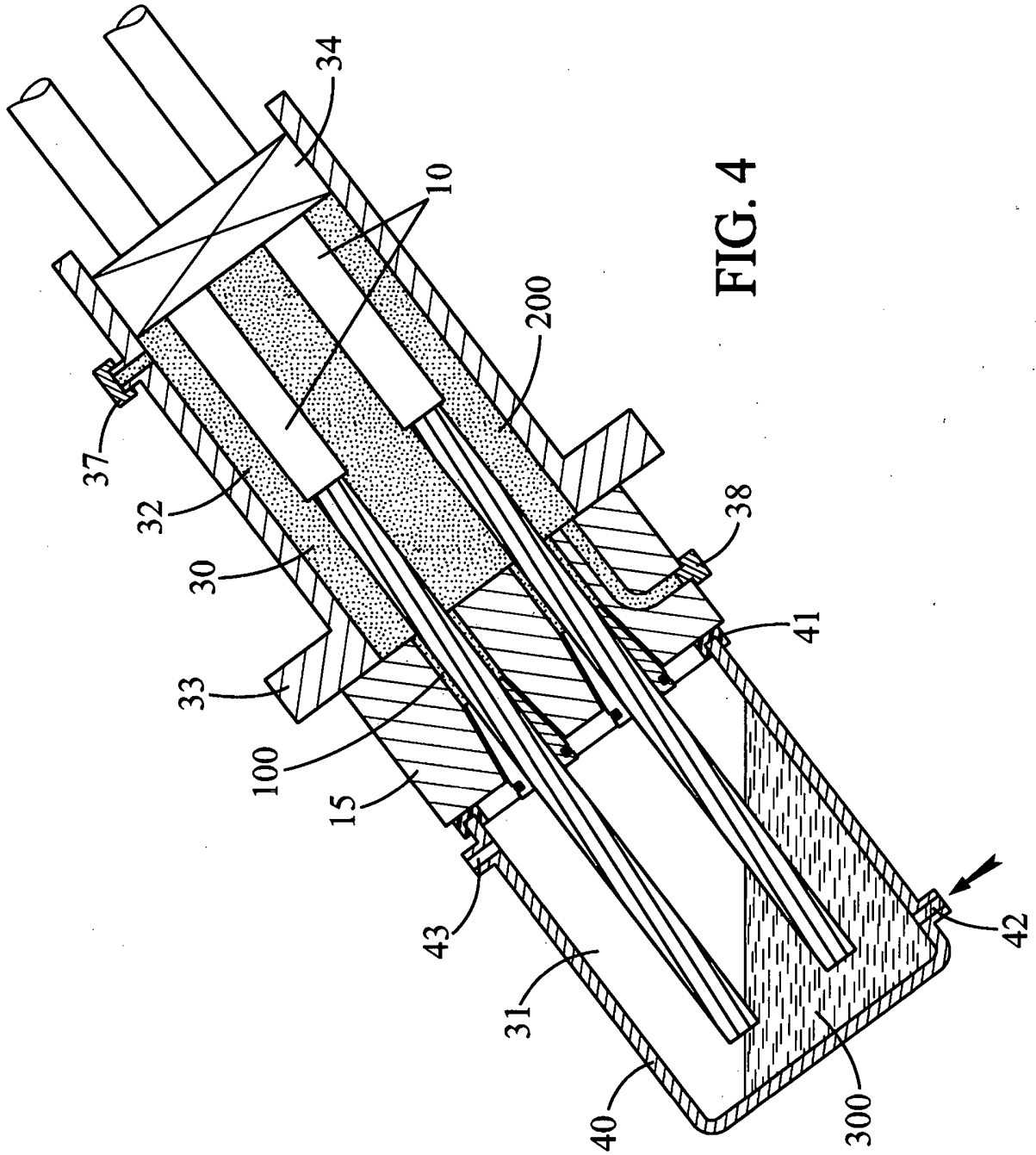

FIG. 2





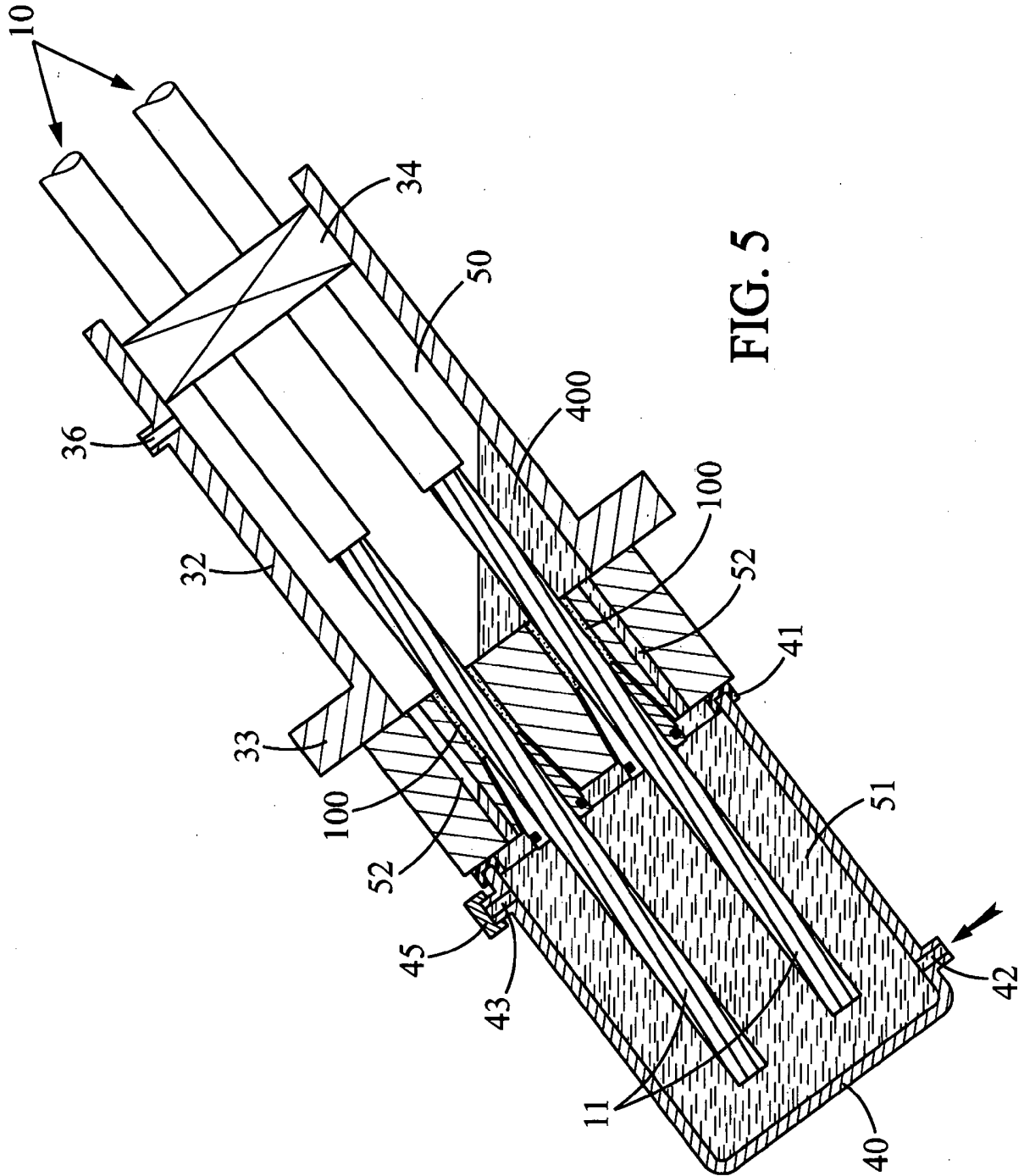

FIG. 5

**REFERENCES CITED IN THE DESCRIPTION**

*This list of references cited by the applicant is for the reader's convenience only. It does not form part of the European patent document. Even though great care has been taken in compiling the references, errors or omissions cannot be excluded and the EPO disclaims all liability in this regard.*

**Patent documents cited in the description**

- WO 0120098 A1 [0009] [0036]
- EP 0896108 A2 [0010]
- EP 1227200 A1 [0010]
- FR 2492870 A1 [0012]
- FR 1152557 [0053]

## SZABADALMI IGÉNYPONTOK

## RÖGZÍTŐ SZERELVÉNY

1. Rögzítő szerelvény, amely tartalmaz egy több feszítőszálból (10) álló kábelt és egy rögzítő eszközt a több feszítőszálból (10) álló kábel számára, amely rögzítő eszköz tartalmaz:

- egy rögzítő blokkot (15) egy első oldallal (18) egy hátsó oldallal (17) és az első oldal és hátsó oldal között húzódó csatornákkal (16, 52), a kábel feszítőszálainak mindegyike egy záró elemmel (19) egy megfelelő csatornába van befogva;

egy első védőanyagot (100), amelyet a rögzítő blokk (16) legalább egyik csatornája foglal magában, ahol a csatornák mindegyike befogadja a feszítőszálak egyikét;

egy, a kábel több feszítőszálának végrészeit tartalmazó, a rögzítő blokk első oldalán elhelyezett kamrát (31, 50-51); azzal jellemezve, hogy a berendezés tartalmaz továbbá

egy, az első védőanyagtól eltérő, a kamrát kitöltő második védőanyagot (300, 400) a kábel több feszítőszálának (10) végrészeivel kapcsolódóan.

2. Az 1. igénypont szerinti rögzítő szerelvény, amelyben az első védőanyag (100) viasz vagy zsír.

3. Az 1. vagy a 2. igénypont szerinti rögzítő szerelvény, amelynél a rögzítő blokk (15) hátsó oldalán nincsen kamra, és ahol a második védőanyag polimer vagy gyanta.

4. Az 3. igénypont szerinti rögzítő szerelvény, amelyben az első védőanyag polimer vagy gyanta.

5. Az 1. vagy a 2. igénypont szerinti rögzítő szerelvény, ahol a rögzítő eszköz tartalmaz a rögzítő blokk (15) hátsó oldalán (17) egy, a kábel feszítőszálainak (10) feszített részeit tartalmazó első kamrát (30), és a rögzítő blokk első oldalán (18) egy a kábel feszítőszálainak végrészeit tartalmazó második kamrát (31), ahol az első és a második kamra (30, 31) mindegyike tartalmaz védőanyagot.

6. Az 5. igénypont szerinti rögzítő szerelvény, ahol az első kamra (30) védőanyaga (200) eltérő a második kamra (31) védőanyagától (300).

7. Az 5. vagy a 6. igénypont szerinti rögzítő szerelvény, amelynél az első kamra (30) védőanyaga (200) polimer vagy gyanta.

8. Az 5-7. igénypontok bármelyike szerinti rögzítő szerelvény, amelynél a második kamra (31) védőanyaga (300) viasz vagy zsír.

9. Az 1. vagy a 2. igénypont szerinti rögzítő szerelvény, ahol a rögzítő blokk (15) első és hátsó oldalán a kamrának két része (50-51) van, legalább egy, a rögzítő blokkon

keresztül húzódó és a második védőanyaggal (400) kitöltött közlekedő csatornával (52) összekötve.

10. A 9. igénypont szerinti rögzítő szerelvény, ahol a rögzítő blokk (15) összekötő csatormáján (52) nem halad át a kábel feszítőszála.

A meghatalmazott:

Mészárosné Dónusz Katalin  
vezető ügykezelő  
SOKK Szabványos Úgykezelő Zrt.  
H-1047 Budapest, Árpád utca 111.  
Telefon: 06 1 306 1000  
E-mail: sokk@szokk.hu