

Jan. 31, 1928.

1,657,978

H. ST. PIERRE

CHAIN PLIERS

Filed May 15, 1925

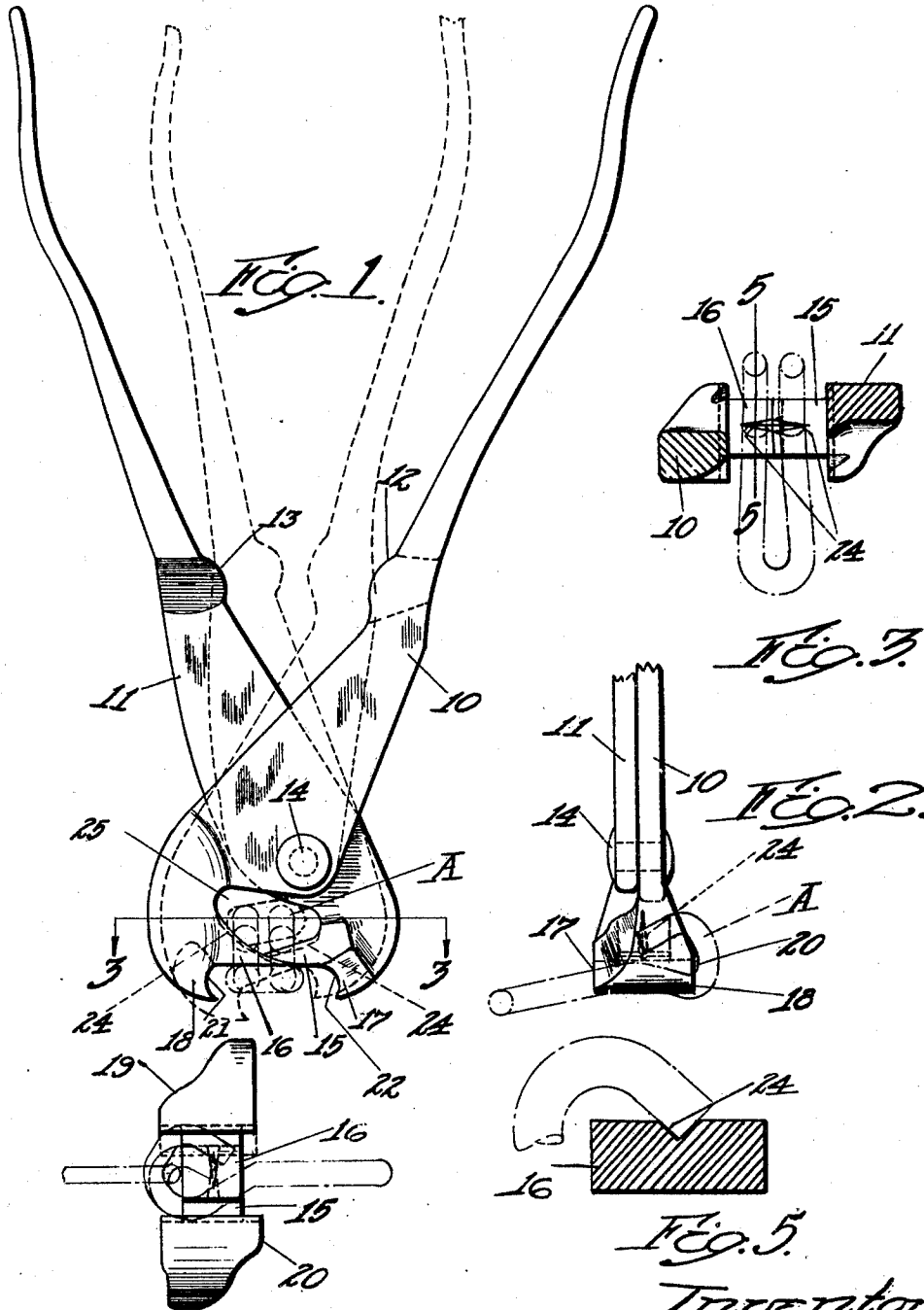

Inventor:
Henry St. Pierre
By Attorneys.
Southern F. & H. Co.

UNITED STATES PATENT OFFICE.

HENRY ST. PIERRE, OF WORCESTER, MASSACHUSETTS, ASSIGNOR TO ST. PIERRE CHAIN CORPORATION, OF WORCESTER, MASSACHUSETTS, A CORPORATION OF MASSACHUSETTS.

CHAIN PLIERS.

Application filed May 15, 1925. Serial No. 30,592.

This invention relates to a pair of pliers which are capable of several uses and particularly designed for use in attaching and disconnecting the cross chains of automobile tire chains. The principal object of the invention is to provide a single implement with only two parts, a simple and convenient pair of cooperating separating jaws, for loosening the end links of cross chains so as to be able to detach them from the circumferential chains and at the same time to provide a convenient pair of closing jaws so related that they can be used for closing the end links of these cross chains.

Other objects and advantages of the invention will appear hereinafter.

Reference is to be had to the accompanying drawings in which

Fig. 1 is a side view of the pair of pliers constructed in accordance with this invention shown in open position and illustrating a nearly closed position in dotted lines as used for opening a link;

Fig. 2 is an edge view of the jaws in open position and in the act of starting to open the end link of the chain;

Fig. 3 is a sectional view of the line 3—3 of Fig. 1;

Fig. 4 is an end view showing the jaws in the same positions as in Fig. 1 in full and dotted lines as used for closing a link, and

Fig. 5 is an enlarged sectional view on the line 5—5 of Fig. 3.

As will appear, the tool consists of two pivoted levers 10 and 11. The handles of these levers are provided with integral stops 12 and 13 to limit the closing action of the jaws which are located on the other side of the pivot pin 14 on which the two levers are pivoted together. The jaws comprise a pair of separating bills 15 and 16 and a pair of transverse closing jaws 17 and 18 located at the butt or larger ends of the bills. The separating bills are of flat wedge shape but at the outer side of the bill 15 and the inner side of the bill 16 are drawn on an arc concentric with the pivot pin 14, one overlapping the other so that when brought together as shown in dotted lines these jaws slide along each other without binding. Moreover, when the bills are entirely closed, there is left inside the separating jaws an oblong space 25, in which the two wires of a link

can be received. This is to permit of the reception of the end hook or loop of the chain in proper position for separating in any desired manner.

The parts 15 and 17 are integral with each other as are also the parts 16 and 18. The closing jaws 17 and 18 are located opposite each other as projections from the outer sides of the butt ends of the wedge shaped separating or opening bills 15 and 16 which have sharp grooves 24 along their inner concave faces for receiving the two angular tips of the chain links or loops and holding them in proper position as shown in Figs. 3 and 5. The stops 12 and 13 prevent these two jaws closing together much further than shown in dotted lines in Fig. 1. It will be seen that one of the jaws 17 is located nearer the pivot 14 than the jaw 18 as that is a convenient way to make the tool less bulky than it would otherwise. It will be noted also, by referring to Figs. 3 and 4, that there are two projections 19 and 20 on the ends of the two jaws 17 and 18 extending beyond the edges of the bills on opposite sides of the tool, which limit the position of the chain in the tool. The ordinary end link has a slanting end which would cause it to be pushed out of the jaws if they did not project beyond the bills 15 and 16 laterally. These wide jaws also keep the link straight after the edge gets out of the grooves 24 (see Fig. 4).

In the operation of the device for the opening of a link A or loop as indicated in Figs. 1, 2 and 3 the tool is opened and the two wires constituting one of the ends of the loop are placed in the space 25, above described, inside the separating bills with their angular ends engaging in the groove 24 as shown in Fig. 5. The two ends of these two bills are guided opposite each other into the space between the wires of the loop A which it is desired to expand or open. The fact that these loops have two pairs of wires in the same plane enables the operator to hold the loop rigidly in position. For the purpose of adding to the stability of the loop when held by the jaws they are provided at their extreme ends with concave surfaces at 21 and 22 located across the jaws. The link having been placed in position, the operator no longer has to bother with holding it as

it will be held by this tool throughout the remainder of the operation. Now the operator takes hold of the two handles, one at each end preferably, and forces the two bills or separating jaws toward each other which results in gradually increasing the distance between the extreme end of the link and the main body thereof. This separates the link A and opens the hook so that it can be removed from the side chain.

For the purpose of again closing this link or a new one, the operator grasps each side of the double link separately in the jaws 17 and 18 as shown in Fig. 4 and by the use of one hand presses this loop into a closed position with the end of the wire engaging in the eye of the link. One of the two wires having been closed in this way, the instrument is applied to the other one and it is closed in the same way. One of the projections 19 or 20 will prevent the slipping of the link during this action. These projections extend out in opposite directions on opposite sides and serve to engage the hook near the free end as shown in dotted lines in Fig. 4.

This constitutes a very compact and durable implement for this purpose. It is easily operated by skilled or unskilled labor. It holds the chain link while the operation is being performed so that the operator does not have to support the chain or handle it in any way after the operation is once commenced. It has a space for receiving the loop or link which is located near the pivot and is so constructed that heavy leverage is secured to permit a man of normal strength to open any link now used on automobile tires or to close it without exerting an excessive amount of strength.

The jaws 17 and 18 are not symmetric with respect to their handles, being at different distances from the pivot 14. This brings one of them off to one side, so that the user can have better access to the chains in certain positions than he could if they were both in line with the handles.

Although I have illustrated and described only a single form of the invention I am aware of the fact that modifications can be made therein by any person skilled in the art without departing from the scope of the invention as expressed in the claims.

Therefore, I do not wish to be limited to all the details of construction herein shown and described, but what I do claim is:—

1. As an article of manufacture, a pair of pliers for the purpose described comprising a pair of levers pivoted together, each having an integral wedge-shaped separating bill located at a short distance from the pivot on the end opposite the handle end of the lever for opening a chain link or loop and each bill being provided with a jaw at its butt end and at the extreme end of

the pliers transverse to the length of the pliers and having a concave surface located across it for engaging and holding the outer surfaces of a hook or link and closing the same.

2. As an article of manufacture, a pair of pliers for the purpose described comprising a pair of levers pivoted together between their ends, each having an integral opening bill beyond the pivot adapted to cooperate to separate a chain link or loop and each opening bill being provided with a projection on its extreme end on the side of the bill opposite the pivot and transverse to the length of the tool for engaging the outer surfaces of a hook or link and closing them.

3. As an article of manufacture, a pair of pliers for the purpose described comprising a pair of levers pivoted together each having a separating bill located at a short distance from the pivot and adapted to cooperate for opening a chain link or loop, each separating bill being provided with a groove extending along the inner surface of the bill, for receiving the tip of a hook or link and holding the same in proper position during the operation.

4. As an article of manufacture, a pair of pliers for the purpose described comprising a pair of levers crossing each other and pivoted together, each having an opening bill beyond the pivot and each being provided with a transverse jaw on the bills for engaging the outer surfaces of a hook or link and closing the same, said transverse jaws each extending beyond the edges of the bills on opposite sides to prevent slipping of the link being operated on.

5. A tire chain tool comprising a pair of pivoted cross jaw members terminating at their operating ends in inwardly facing oppositely disposed jaws, said jaw members inwardly of said jaws having overlapping oppositely disposed wedging bills, said jaws constituting shoulder abutments against which the hooked ends of a hook being opened may bear to prevent relative movement of the hook on the bills as the bills are pressed towards each other to open the hook.

6. A tire chain tool comprising a pair of pivoted crossed jaw members terminating at their operating ends in inwardly facing oppositely disposed jaws, said jaw members inwardly of said jaws having overlapping oppositely disposed wedging bills, said jaws constituting shoulder abutments adapted to bear against and close the hooked ends of a hook supported on said bills when the jaw members are pressed towards each other.

7. A tire chain tool comprising a pair of pivotally crossed jaw members shouldered at their operating ends and having in-

wardly of said shoulders a pair of inwardly extending overlapping hook opening bills, said shoulders being alternatively effective in the opening action of the tool as abutments to prevent relative movement of the hook on the bills while it is being opened, and effective in the closing action of the tool as a pair of oppositely moving closing jaws adapted to directly engage and close a hook supported on said bills. **10**

In testimony whereof I have hereunto affixed my signature.

HENRY ST. PIERRE.