

(No Model.)

W. F. ZIEGLER.  
CORN HARVESTER.

No. 522,094.

Patented June 26, 1894.

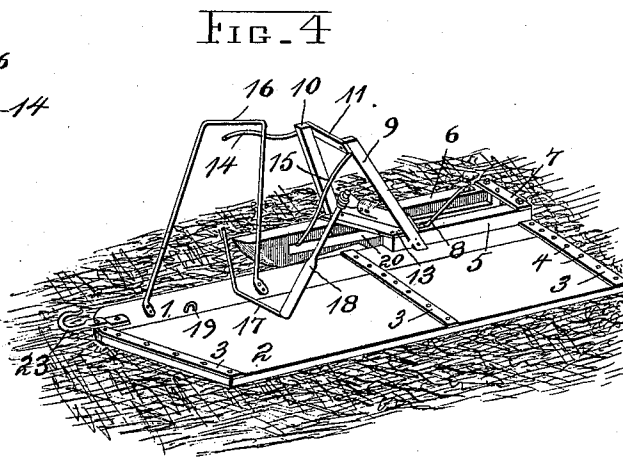
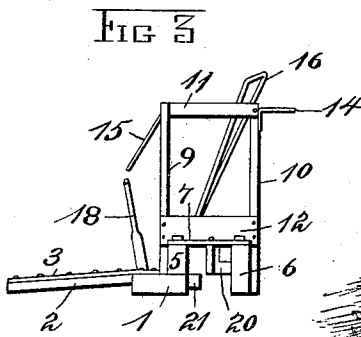
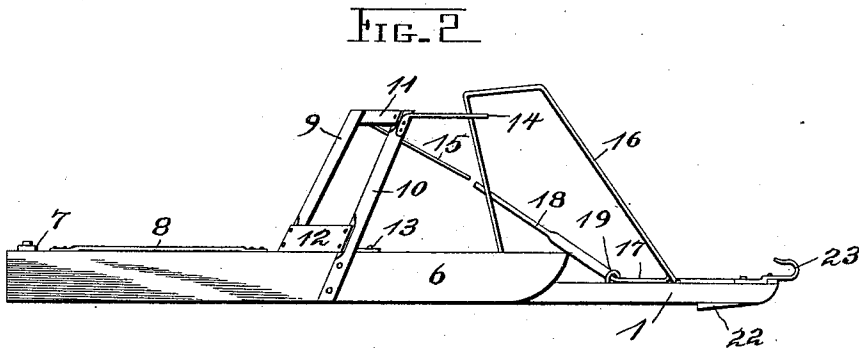
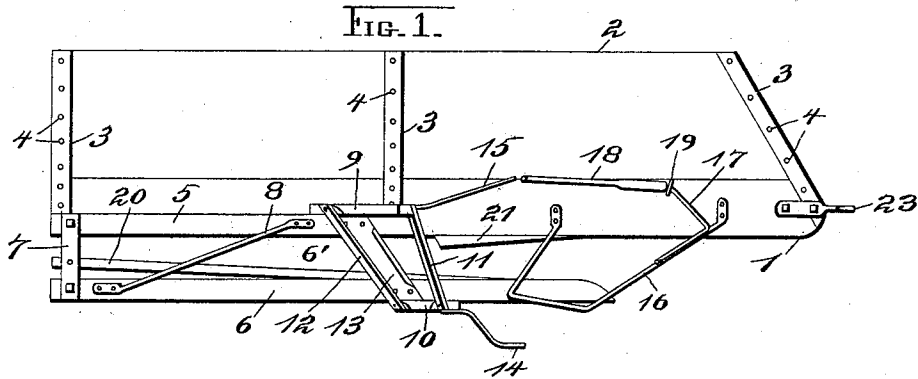

Witnesses  
*W. J. Hawley.*  
*J. Cunyan.*

Inventor  
*William F. Ziegler*  
By *Higdon Higdon Longan*  
*Attys.*

# UNITED STATES PATENT OFFICE.

WILLIAM F. ZIEGLER, OF LINCOLN, KANSAS.

## CORN-HARVESTER.

SPECIFICATION forming part of Letters Patent No. 522,094, dated June 26, 1894.

Application filed September 26, 1893. Serial No. 486,564. (No model.)

*To all whom it may concern:*

Be it known that I, WILLIAM F. ZIEGLER, of Lincoln, Lincoln county, Kansas, have invented certain new and useful Improvements in Corn-Harvesters, of which the following is a full, clear, and exact description, reference being had to the accompanying drawings, forming a part hereof.

My invention relates to an improved corn harvester, and consists in the novel arrangement, combination and construction of parts as will be more fully hereinafter described and designated in the claim.

In the drawings: Figure 1 is a plan view of my improved corn harvester. Fig. 2 is a side elevation of the same. Fig. 3 is a rear end elevation. Fig. 4 is a perspective view more clearly showing the same.

1 indicates a longitudinal main timber which is rectangular in cross-section and is constructed to lie flat and slide on the ground when in use.

2 indicates a platform which is connected to one edge of the timber 1 by strips 3 being connected to the upper side of said platform and the upper side of the timber 1 by means of bolts or screws 4. Connected to the upper side of the timber 1 adjacent its rear end and adjacent the opposite edge of said timber from the platform 2 is a strip or timber 5.

6 indicates a runner which is located a suitable distance from the timber 1 on the opposite side from the platform, which forms a passageway 6' between said runner and timber and is of suitable width so that when its lower edge is in alignment with the lower side of the timber 1 its upper edge will be in alignment with the upper edge of the timber 5 it being connected to said timber and held rigid with the timber 1 by a cross-piece 7 and a brace 8, said cross-piece and brace being located on and connected to the upper edge of the bar 5 and the runner 6.

9 and 10 indicate standards which lean forward at a suitable angle; the lower end of the standard 10 is connected to the opposite side of the runner 6 from the timber 1 by being bolted or screwed thereon. The lower end of the standard 9 is connected to the opposite side of the timber or strip 5 from the runner

a suitable distance back from the lower end of the standard 10.

Connecting the upper ends of the standards 9 and 10 is a cross-bar 11 which is connected to the front edge of the standard 9 and the rear edge of the standard 10. Connected to the rear edges of the standards 9 and 10 adjacent the upper edges of the runner 6 and the timber 5 is a board 12. Connected to the upper edges of the runner 6 and the timber 5 and extending across the passageway 6' is a knife 13 the front edge of which is sharpened. Connected to the side of the standard 10 adjacent its upper end is a forwardly projecting rod 14 which is bent so as to extend outward from said standard. Connected to the upper end of the standard 9 and extending forwardly over the timber 1 is a rod or bar 15.

16 indicates an inverted U-shaped bar, the ends of which are connected to the upper side of the timber 1 adjacent its front end which extends at an angle outwardly over the front end of the runner 6 and the passageway 6'.

17 indicates a detachable hook which is constructed with a handle 18 as shown in Figs. 1 and 2. Said hook is held in position by an eye or staple 19 connected to the upper side of the timber 1 as shown in said figures. Connected to the inner side of the runner 6 adjacent its front end and extending rearwardly therefrom is a guide-bar 20, the rear end of which is connected to the lower side and held in position by the cross-piece 7. Connected to the edge of the timber 1 adjacent the front end of the runner 6 is a wedge-shaped guide 21 which is depressed at its front end and its rear end extends outward into the passageway 6'. Connected to the lower side of the timber 1 adjacent its front end is a shoe 22 to allow said timber to move easily over rough ground. Connected to the upper side of the timber 1 adjacent its front end is a hook 23 to allow draft animals to be hitched thereto for moving the harvester.

The operation is as follows: When it is desired to cut corn the operator drives the draft animal so the edge opposite from the platform 2 of the timber 1 will be brought adjacent the row of corn and the U-shaped bar

will strike the row and will push the top of the corn outward and the butts of the corn will pass in between the runner and the timber, and when the tops of the corn pass the upper end of the U-shaped bar 16 it will straighten up and the bar 14 will catch the tops of what corn may be broken and guide it inwardly so that when the corn is cut off by the knife 13 it will fall down on the opposite side of the U-shaped bar 16 onto the platform. After a few hills of corn have been cut the stumps of said corn being in the passageway 6' they will engage with the bar 20 and guide the harvester in a direct line parallel with the rows and prevent the standing corn from pushing it over out of alignment with the row to be cut, the harvester being long enough to allow at least two hills to be in the passageway at the same time and in engagement with the stumps. The cross-bar 11 coming in contact with the standing corn before the knife it will push the corn over and after cutting it off will cause it to fall forward. The board 12 is of suitable height to prevent the butts of the corn when cut off from being pushed backward between the standards 9 and 10. When it is desired to shock corn the operator connects the hook 17 with the eye 19 as shown in Fig. 1 and holds said hook in position by the handle 18 until the required amount is cut then he picks the corn up and carries it to the shock, but when it is desired to cut the corn and place it in rows, the operator removes the hook 17 from the eye 19 and holds it in the position shown

in Fig. 4, which will allow the corn to drop into said hook when cut and when the desired amount is collected he draws the corn off of the platform at the required place by said hook. The bar 15 is to guide the corn into the hook and prevent it from scattering as it falls on the platform.

What I claim is—

In a corn harvester, a main timber to which a platform is connected, a timber 5 connected to the main timber, a runner connected to, and located a suitable distance from, the timber 5 which forms a passage-way between said runner and the timber, a knife located across the passage-way, forwardly leaning standards connected to the runner and the timber 5, a cross-bar connected to the upper ends of said standards, a board connected to said standard adjacent the upper edges of the runner and the timber 5, guide-bars 14 and 15 connected to the upper end of said standard and extending forward therefrom, an inverted U-shaped bar connected to the main timber and extending upwardly and outwardly over the front end of the runner, and a guiding-bar 20 fixed to the cross-bars 7, 13 and adapted to engage the stumps of the cut corn and guide the machine in alignment with the corn rows, substantially as set forth.

In testimony whereof I affix my signature in presence of two witnesses.

WM. F. ZIEGLER.

Witnesses:

D. I. KING,  
R. T. SAVIN.