

(No Model.)

G. W. WRIGHT.
DOOR CHECK.

No. 400,815.

Patented Apr. 2, 1889.

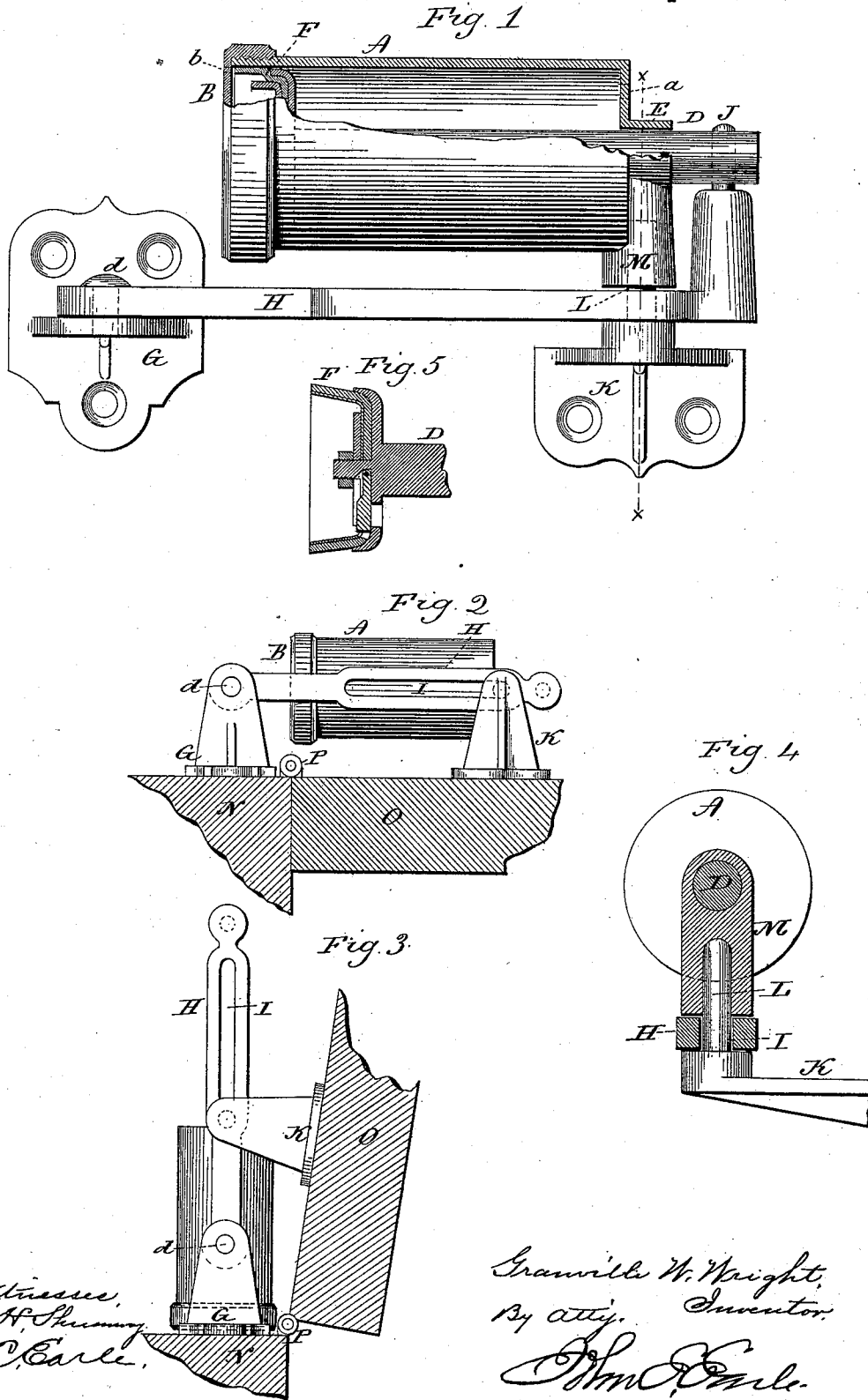

Witnesses,
J. H. Perryman,
F. C. Earle.

Granville W. Wright,
By atty. Inventor.
F. C. Earle.

UNITED STATES PATENT OFFICE.

GRANVILLE W. WRIGHT, OF NEW HAVEN, CONNECTICUT, ASSIGNOR TO
SARGENT & COMPANY, OF SAME PLACE.

DOOR-CHECK.

SPECIFICATION forming part of Letters Patent No. 400,815, dated April 2, 1889.

Application filed January 14, 1889. Serial No. 296,234. (No model.)

To all whom it may concern:

Be it known that I, GRANVILLE W. WRIGHT, of New Haven, in the county of New Haven and State of Connecticut, have invented a new Improvement in Door-Checks; and I do hereby declare the following, when taken in connection with accompanying drawings and the letters of reference marked thereon, to be a full, clear, and exact description of the same, and which said drawings constitute part of this specification, and represent, in—

Figure 1, a face view of the apparatus complete, the cylinder in partial longitudinal section; Fig. 2, an under side view of the apparatus applied to a door, looking up, in the position of the door closed; Fig. 3, the same, the parts in the position of the door open; Fig. 4, a transverse vertical central section through the pivot-socket of the cylinder; Fig. 5, a modification of the piston.

This invention relates to an improvement in that class of door-checks which consist of a piston and cylinder, one secured to the door and the other to a stationary point upon the frame around the door, and so that as the door is opened the piston is caused to move from one end of the cylinder toward the other, and so that on the closing of the door the piston will return, the piston moving freely in the opening direction, but its return resisted by an air-cushion formed in the cylinder in advance of the piston, and particularly to that class in which the piston is not entirely drawn from the cylinder in opening the door; and the invention consists in the construction as hereinafter described, and more particularly recited in the claim.

A represents the cylinder, which is closed at one end by a suitable head, B. (Here represented as screwed upon that end of the cylinder.) The other end of the cylinder may be made close.

C represents the piston, from which a rod, D, extends through a bearing, E, in the end of the cylinder, and so as to support the piston in its proper longitudinal position, but yet allow its free movement. The piston C is of the usual cup shape—that is to say, its side F is made of flexible material, as leather, and capable of an expansion to substantially

fill the cylinder, but yet yield so that the diameter of the piston may become less than the internal diameter of the cylinder. The open face of the piston is best made toward the end of the cylinder opposite that through which the piston passes, and as seen in Fig. 1, and so that as the piston is drawn away from the end of the cylinder which it faces its flexible sides yield to permit the air or whatever it may be on the reverse side of the piston to pass freely through to the face side of the piston. Then as the piston returns the air operates upon the inside of the flexible portion of the piston and causes it to expand against the surface of the cylinder. This forms a cushion against the return of the piston; but the air forming the cushion may escape slowly around the piston to the reverse side of the piston, and thus make the return of the piston slower than its withdrawing movement. This is a common expedient in this class of checks. The piston, however, may be provided with a valve, as seen in Fig. 5, which will permit the air to pass freely through the piston to its face side on the withdrawal of the piston and retard its escape on the return of the piston; or one or more openings, as indicated in broken lines at *a*, Fig. 1, may be made in the end of the cylinder opposite the face of the piston for the free admission and escape of air from that side of the piston, and a vent may be made through the other end, as indicated by broken lines at *b*, for the admission and slow escape of air on the face side of the piston, these modifications being also common and well-known devices in this class of checks.

G represents a bracket, which is adapted to be secured either to the door or jamb, as the case may be, and to the bracket G, upon a pivot, *d*, an arm, H, is hung to swing in a horizontal plane. This arm is constructed with a longitudinal slot, I, vertically through it—that is, in a plane parallel with the axis of the pivot on which the arm swings, (see Figs. 2 and 3,)—and the arm is of a length considerably greater than the length of the cylinder A. The end of the arm H opposite its pivot is constructed with a vertical stud, J, and the outer end of the piston-rod is hung

upon this stud J as a pivot, and as seen in Fig. 1.

K represents the second bracket, which is adapted to be secured to the door or its frame, like the bracket G, one being attached to the door, the other to be attached to the door-frame. The bracket K is constructed with a vertical stud, L, and from the bearing end of the cylinder a socket, M, projects downward and sets upon the stud L as a pivot, and as seen in Fig. 4. The stud L extends through the slot I in the arm H, as also seen in Fig. 4, the cylinder being above the arm H. This completes the construction.

In illustrating the operation of the check I represent the bracket G as secured to the door-jamb N and the bracket K as secured to the door O, the door hinged to the jamb, as at P. In Figs. 1 and 2 the parts are represented as in the position with the door closed, the piston standing near the head B of the cylinder, and the pivot L, on which the cylinder is hung, stands at the opposite end of the slot I in the arm H, as clearly seen in Fig. 2, the pivot *d* being outside of and distant from the hinge P of the door, and the piston, through its rod, is hung upon the extreme end of the arm H; hence in the opening movement of the door the piston cannot change its relation to the pivot *d*, nor can the cylinder change its relation to its pivot L on the door; hence it follows that the piston, being held by the arm H, the pivot L and the cylinder it carries must necessarily approach the pivot *d* on which the arm is hung, and as seen in Fig. 3, the cylinder-pivot L moving through the slot I. This operation causes the piston to be drawn through the cylinder toward the opposite head. The slot in the arm serves as a guide to retain the cylinder and piston in their proper relation to each other and to the re-

spective pivots. To the withdrawing movement of the piston little resistance is offered, as before described; but on the return or closing movement of the door, as from Fig. 3 to Fig. 2, the piston returns into the cylinder toward the head B, and because the escape of the air then in advance of the cylinder is slow a cushion is formed to resist this return of the piston and cylinder upon each other, and this resistance retards the closing of the door, so as to prevent its slamming, it being understood that usually a spring, weight, or other mechanical expedient is employed to forcibly close the door.

From the foregoing it will be evident that I do not claim, broadly, a door-check consisting of a cylinder and piston, one attached to the door and the other to the door-frame, so that the opening of the door draws the piston through the cylinder, and on the closing of the door a cushion is formed to resist the rapid return of the piston; but

What I do claim is—

The combination of two brackets, one adapted to be attached to the door and the other to the frame of the door, an arm hung to one of the brackets and so as to swing in a horizontal plane, the said arm constructed with a longitudinal slot vertically through it, the other bracket carrying a pivot which extends through said slot in the arm, a cylinder hung upon said pivot of the said other bracket, a piston in said cylinder, and a rod extending from the piston through the head of the cylinder and hung upon a pivot upon the free end of the said arm, substantially as and for the purpose described.

GRANVILLE W. WRIGHT.

Witnesses:

WM. S. COOKE,
JOHN C. PAGE.