



INTERNATIONAL APPLICATION PUBLISHED UNDER THE PATENT COOPERATION TREATY (PCT)

<p>(51) International Patent Classification⁴ : E21B 7/06</p>	<p>A1</p>	<p>(11) International Publication Number: WO 87/ 02408 (43) International Publication Date: 23 April 1987 (23.04.87)</p>
<p>(21) International Application Number: PCT/US86/01987 (22) International Filing Date: 23 September 1986 (23.09.86) (31) Priority Application Number: 786,817 (32) Priority Date: 11 October 1985 (11.10.85) (33) Priority Country: US</p> <p>(71) Applicant: SMITH INTERNATIONAL, INC. [US/US]; 4490 Von Karman, Newport Beach, CA 92660 (US). (72) Inventors: BELA, Geczy ; 6004 East Bryce, Orange, CA 92626 (US). DeLUCIA, Frank ; 19434 Raskin Drive, Rowland Heights, CA 91748 (US). (74) Agent: GESS, Albin, H.; Price, Gess & Ubell, 4740 Von Karman, Suite 100, Newport Beach, CA 92660 (US).</p>		<p>(81) Designated States: AT (European patent), BE (European patent), CH (European patent), DE (European patent), FR (European patent), GB (European patent), IT (European patent), LU (European patent), NL (European patent), NO, SE (European patent).</p> <p>Published <i>With international search report.</i> <i>With amended claims.</i></p>

(54) Title: SYSTEM AND METHOD FOR CONTROLLED DIRECTIONAL DRILLING

(57) Abstract

A system and method for controlled directional drilling utilizes a systematic approach to designing the hardware for drilling according to a well plan. The bend angle (a) of a bent housing (21), connected between the bit (15) and a downhole motor (25), the diameter of a plurality of stabilizers (19, 29, 31 and 33) and placement of the stabilizers with respect to the drill bit (15) are selected and predetermined on the basis of the desired well plan. With the use of an MWD, the direction of the progressing borehole is tracked from the surface. Direction changes as required are controlled from the surface simply by controlling rotation of the drillstring (27). For curved path drilling, only the downhole motor (25) is rotated, causing the borehole (13) to travel along the curve determined by the bend angle (a) in the bent housing (21) and the diameter and location of the concentric stabilizers (19, 29, 31 and 33). When straight hole drilling is required, both the downhole motor (25) and the entire drill string (27) are rotated, effectively nullifying the effect of the bend angle (a) in the bent housing (21).

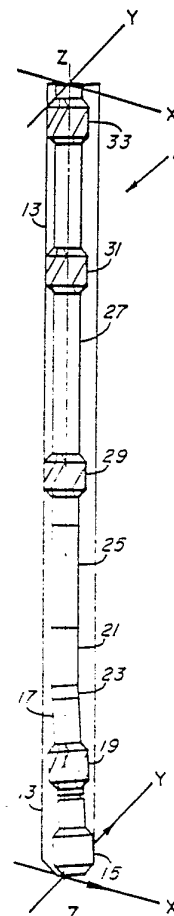

FOR THE PURPOSES OF INFORMATION ONLY

Codes used to identify States party to the PCT on the front pages of pamphlets publishing international applications under the PCT.

AT	Austria	FR	France	ML	Mali
AU	Australia	GA	Gabon	MR	Mauritania
BB	Barbados	GB	United Kingdom	MW	Malawi
BE	Belgium	HU	Hungary	NL	Netherlands
BG	Bulgaria	IT	Italy	NO	Norway
BJ	Benin	JP	Japan	RO	Romania
BR	Brazil	KP	Democratic People's Republic of Korea	SD	Sudan
CF	Central African Republic	KR	Republic of Korea	SE	Sweden
CG	Congo	LI	Liechtenstein	SN	Senegal
CH	Switzerland	LK	Sri Lanka	SU	Soviet Union
CM	Cameroon	LU	Luxembourg	TD	Chad
DE	Germany, Federal Republic of	MC	Monaco	TG	Togo
DK	Denmark	MG	Madagascar	US	United States of America
FI	Finland				

-1-

SYSTEM AND METHOD FOR CONTROLLED
DIRECTIONAL DRILLING

BACKGROUND OF THE INVENTION

1. Field of the Invention

5 The present invention relates generally to
improvements in controlled directional drilling systems
and more particularly pertains to a new and improved
system and method for controlling the directional
drilling of the borehole in a manner which will allow the
10 borehole to be drilled in conformance with the proposed
well plan.

2. Description of the Prior Art

15 In the field of controlled directional drilling
of boreholes, until very recently, it had been the
practice to use two separate down-hole systems. One
system was used for drilling straight holes. A
completely different system was used for causing the
borehole to turn direction. The use of these two systems
required that the entire drillstring be tripped or pulled

SUBSTITUTIONAL SHEET

-2-

from the borehole so that the down-hole system could be changed each time a change of direction was required. This type of system is described in SPE Paper No. 9649 entitled "Kicking Off in Large Diameter Holes" presented at the 1981 SPE Middle East Oil Technical Conference held in Manama, Bahrain, March 9-12.

Although such systems produced results, they were unsatisfactory in several major respects. Considerable time was wasted as a result of the non-drilling activity occasioned by having to trip the bottom-hole assembly, either to follow the curvature in the well plan or to make corrections for unforeseen deviations in the borehole. This type of operation considerably increased the drilling time and decreased the rate of penetration (ROP). Another problem with this system is that the standard straight-hole drilling, bottom-hole assemblies utilized, deviated, sometimes considerably, from the well plan. In such a case, not only will the driller not reach his target but he will end up with a crooked hole, worn casing, stuck pipe, and expensive fishing jobs.

Deviating boreholes have been a subject of concern to this industry for a long time. Many approaches have been tried to first understand the multifacet problem and then to come up with a workable

-3-

solution. One example of such an approach can be found in SPE Article No. 5070 entitled "Factors Affecting the Control of Borehole Angle In Straight and Directional Wells" presented at the SPE-AIME 49th Annual Fall Meeting in Houston, Texas, October 6-9, 1974.

One of the problems confronting the industry with respect to the drilling of directional boreholes and deviation of boreholes from a well plan was obtaining accurate information about the direction of the borehole. As a result, the industry developed systems for monitoring while drilling (MWD systems). In order to be able to ascertain when a borehole is deviating from its well plan and to be able to ascertain and control the direction of the borehole in order to follow the well plan, many different types of monitoring systems were developed.

A certain number of these systems are discussed, for example, in SPE paper No. 9224, entitled "A Case Study Comparison of Wells Drilled With and Without MWD Directional Surveys on the Claymore Platform in the North Sea" first presented at the SPE 55th Annual Technical Conference and Exhibition in Dallas on September 21-24, 1980. Another example can be found in SPE paper No. 10053 entitled "Mud Pulse MWD Systems Report" first presented at the SPE 56th Annual Technical Conference and Exhibition in San Antonio on October 4-7, 1981.

-4-

Another aspect of the problem confronting anyone attempting to drill a directional well at increased ROP without increasing cost, was the requirement of a powerful down-hole motor to turn the borehole, when
5 required by the well plan, or to bring a deviated borehole back to the well plan. Such motors have been the focus of industry attention for considerable time and are now, to a reasonable extent, available. A description of a type of down-hole motor available at the
10 present time can be found in SPE paper No. 13026 entitled "PDM vs. Turbodrill: A Drilling Comparison", presented at the 59th Annual Technical Conference and Exhibition in Houston, Texas September 16-19, 1984.

Even with all of these available pieces of a
15 bottom hole assembly, the procedure for drilling a directional well was still to trip the drill string when a change in the direction of the borehole was called for by the well plan. In spite of the ability to monitor while drilling the direction of the borehole, the use of
20 powerful down-hole motors, and the ability to modify various factors like bit weight while the bottom-hole assembly was in the hole, boreholes still deviated from the well plan, requiring tripping of the drillstring and adjustment of the bottom-hole assemblies, as well as
25 adjustment of the stabilizers on the drillstring. A

-5-

method was needed which would considerably reduce, if not eliminate entirely, the round trips required with kick-off techniques and assembly changes for directional control of the borehole. A technique which shows promise and is currently being utilized by various operators in the industry is described in a paper by A.W. Kamp and R. Feenstra entitled "A Technique for Continuously Controlled Directional Drilling" presented at the Drilling Technology Conference of the International Association of Drilling Contractors in Dallas, Texas on March 19-21, 1984. The technique involves the use of a powerful down-hole motor and various ways of creating a side force on the bit or tilting the axis of the bit with respect to the axis of the borehole. It has been found that the bit will drill straight when both the drill string and the motor are rotated, and the bit will deviate in a desired direction when only the motor is rotated and the drillstring is kept stationary in a controlled tool face direction.

Since the introduction of this technique, various entities in this industry have developed a variety of bottom-hole assemblies to take advantage of its possibilities. Some systems have proven more promising than others. Each system in its own way, is

-6-

searching for a reduction in drilling time by increasing rate of penetration and thereby reducing the cost of the well. One such system is described in an article entitled "Drill Faster, More Accurately With New Navigation System" published in World Oil on August 1, 1985 and authored by T. Brassfield and H. Karlson.

The present invention is an improvement over the systems presently available and being tried by the industry to increase ROP of a directional well. The improved performance of the present invention is based on the fact that an overall system approach to each drilling job is utilized. In other words, the bottom-hole assembly is uniquely tailored for each proposed well plan by taking into consideration a myriad of facts such as hole condition, pump data, type of mud being utilized, type of formation being drilled, drilling assembly components, drilling flow rate, well plan, i.e. direction of the borehole after deviating from vertical, in addition to information about the drilling bit which includes bit size, bit type, bit pressure drop, and gauge length, as well as degrees of offset of the center line of the bit face from the center line of the borehole. This information is utilized according to the present invention to come up with a bottom hole assembly and

-7-

method of building a bottom hole assembly which provides an ROP for directional wells which is considerably higher than was heretofore possible.

SUMMARY OF THE INVENTION

5 A system approach to the design of a down-hole assembly for directional drilling requires establishing the value for a series of important variables on the basis of the proposed well plan. The major variables which are systematically determined are bit offset from
10 center, determined by the angle of bend in a bent housing located between the motor and the bit, exact placement along the drillstring of a plurality of concentric stabilizers with respect to the bit, diametric size of each concentric stabilizer with respect to the diameter
15 of the borehole, and to a lesser degree weight on the bit. The entire system, when assembled for a particular well plan is capable of following that well plan with only slight directional correction in the borehole. Directional corrections are made and control of the
20 system is maintained by rotating the down-hole motor only, for curved travel of the drillstring, and rotating the motor and drill string together for straight travel of the drillstring.

SUBSTITUTE SHEET

-8-

BRIEF DESCRIPTION OF THE DRAWINGS

The objects and many of the attendant advantages of this invention will be readily appreciated and become readily apparent as the same becomes better understood by reference to the following detailed description, when considered in conjunction with the accompanying drawings, and in which like reference numerals designate like parts throughout the figures thereof and wherein:

Figure 1 is a diagrammatic illustration of the basic components of the bottom-hole assembly of the present invention;

Figure 2 is a diagrammatic illustration showing how the bit offset is obtained in the bottom-hole assembly according to the present invention;

Figure 3 is a vector illustration showing how the bottom hole assembly of the present invention drills in a controlled direction;

Figure 4 is a table and component diagram for a bottom-hole assembly built according to the present invention illustrating the interrelationship of the basic components of the bottom-hole assembly;

Figure 5 is an alternate table and diagram illustrating a different relationship between the basic components of the bottom-hole assembly of the present invention; and

-9-

Figure 6 is a vertical section of a borehole showing the accuracy with which the actual borehole follows the proposed well plan.

DESCRIPTION OF THE PREFERRED EMBODIMENT

5 Referring first to Figure 1, the basic components of the bottom hole assembly 11 of the present invention are illustrated. The borehole 13 is shown in an oversized and exaggerated manner and is illustrated as being capable of moving in three dimensional space as
10 defined by the Cartesian coordinates x, y and z. The z axis is for the purposes of illustration, defined as the center line of the borehole 13.

The first element of the bottom-hole assembly of the present invention is the drill bit 15 which is
15 connected to a shaft that is concentrically located within a bearing assembly 17. This shaft is in turn connected through a bent housing 21 to the output shaft of the down-hole motor 25. The housing of the down-hole motor 25 is in turn connected to the drill string casing
20 27 which extends all the way to the surface of the borehole 13 and is in turn connected to a means for rotating the entire assembly from the surface (not shown). The bottom-hole assembly, according to the present invention, also includes at least three and preferably four

-10-

stabilizers 19, 29, 31 and 33 precisely located along the drill string with respect to the drill bit 15 and with respect to each other.

5 An important thing to remember with respect to the illustration of Figure 1 is that the centerline of the bit 15 is offset from the centerline of the borehole 14 in an amount determined by the offset 35 (Fig. 2) which is fixed by the bent housing 21, 23 that is connected between the down-hole motor 25 and the motor bearing assembly 17. The utilization of a bent housing 10 21 at this precise point in conjunction with the concentric stabilizers as shown in Figure 1 has proven to be a major factor in increasing the rate of penetration of this particular bottom-hole assembly beyond that heretofore available.

15

Referring now to Figure 2, the bit offset created by the bent housing 21, 23 is illustrated in more detail. Figure 2 illustrates the turning mechanism of the bottom-hole assembly built according to the present invention. This turning mechanism includes the bent housing 21, 23 having a specific tilt angle 35 and a concentric stabilizer 19 located down-hole of the tilt point 23 on the bent housing 21, 23, and very close to bit 15 on bearing housing 17. The drive shaft for bit 15 is concentric within bearing housing 17, resulting in an

20

25

-11-

offset 35 of the center of the face of the bit 15 from the centerline of the borehole 13 by an angle which is the tilt angle 35 of the bent housing 21.

The down-hole motor 25 utilized with this type of arrangement is preferably a positive displacement motor of the type described in the SPE paper No. 13026 entitled "PDM Versus Turbo-Drill: A drilling comparison". The concentric stabilizer 19 located close to the bit 15 serves mainly to maintain the bit offset angle 35 by minimizing the deflections which might increase or decrease this offset angle.

Although all the elements of the bottom-hole assembly, as shown in Figure 1 of the present invention, affect the direction of the borehole that will be drilled by the bottom-hole assembly, it is convenient to consider the bearing stabilizer 19 and the bent housing 21, 23 as the key factors in determining the extent to which the borehole will deviate from the vertical. Experience and mathematical modeling have in fact born out this analytical simplification.

Referring now to Figure 3, a curve which is made up of a plurality of segments 37, 45, 49, 53 and 57 is illustrated as the curve along which the bottom-hole assembly of the present invention will travel as determined by the elements of the bottom-hole assembly

-12-

including bearing stabilizer 19 and the other stabilizers making up the bottom-hole assembly. The bottom most three stabilizers can be thought of as defining points on a circle which determine the radius of the circle. A portion of the circumference of this circle is illustrated in Figure 3 as the path of travel of the bottom-hole assembly. The vertical distance 59 for the curved path traveled is for convenience considered to be a segment of 100 feet.

10. The initial deviation from vertical 39 of curved segment 37 is determined by the bit offset 41 which is controlled by a tilt angle of bent housing 21, 23. The bit 15 will travel along this offset path 37 for a length 61 which is approximately equal to the length of the bearing assembly 17. Whereupon the bit will again follow its offset 41 to drill the next straight segment 45 rather than continue straight along segment 43, and so on to segments 53 and 57. The composite result is a curved path which deviates from the original vertical 39 by a total angle in degrees which is related to the angle of offset 41 created by the tilt angle in bent housing 21, 23.

25. Referring once more to Figure 1, the bearing stabilizer 19 and the bent housing 21, 23 is considered the part of the overall system which gives the bottom-hole assembly the capability of turning left or right in a

-13-

controlled manner. The three concentric stabilizers 19, 29 and 31 and, preferably the fourth concentric stabilizer 33 can be considered as the part of the bottom-hole assembly which gives the assembly the ability to maintain a straight course, or to build or drop angle. Thus, the bottom-hole assembly of the present invention is really a unique combination of two overlapping systems which are integrated to provide the bottom-hole assembly with its unique performance capabilities.

The selection of the diameter and placement of the concentric stabilizers 19, 29, 31 and 33, as well as the tilt angle α of the bent housing 21, 23 are the key factors in determining the performance of the bottom-hole assembly of the present invention.

As a result of mathematical modeling with the aid of a computer and field experience, it has been possible to come up with a definition of the interrelationship between the stabilizers and the offset angle α of the bent housing in order to achieve a specific drilling direction. Figure 4 illustrates one such set of relationships.

The basic down-hole assembly components are the drill bit 63, the concentric stabilizers 65, 69, 71 and 73, and the bent housing 67, having an offset angle α .

.-14-

Performance of this bottom-hole assembly, is changed by varying the distance of each stabilizer from the bit 63. That is the distance L1 of stabilizer 65 from bit 63, the distance L1 + L2 of the stabilizer 69 from the bit 63, 5 the distance L1 + L2 + L3 of the stabilizer 71 and the distance L1 + L2 + L3 + L4 of the stabilizer 73 from the bit 63. The angle α is an important contributing factor, as well as the amount of undersize Δd 75 of each stabilizer with respect to the hole size. The amount of 10 weight on bit (WOB) is a factor, as are various other variables mentioned above, to a minor extent.

Consider now various examples of bottom-hole assemblies which for convenience are designated as assemblies A, B and C. Considering first assembly A, the 15 hole size is given as 12-1/4 inches. Hole washout, as a result of the bottom-hole assembly will be negligible. This bottom-hole assembly utilizes a bent housing which has a bit offset angle α of 1/4 of a degree. The placement of the four stabilizers is as follows. The 20 bearing stabilizer 65 is located a distance L1 from the bit which is equal to 4-1/4 feet. Stabilizer 69 is located a distance L2 from the stabilizer 65 which is a distance of 31 feet. Stabilizer 71 is located a distance L3 from stabilizer 69 which is a distance of 45 feet. 25 Stabilizer 73 is located a distance L4 from stabilizers

-15-

71 which is a distance of 35 feet. Each of the stabilizers are concentric and undersized with respect to the hole diameter an amount Δd which is equal to .032 inches. The location of the four stabilizers 65, 69, 71 and 73 at these specific distances with respect to the bit 63 has been found to create a system that will build .30 degrees per 100 feet regardless of the variation of the weight on bit from 10,000 pounds to 40,000 pounds.

Looking now at the bearing concentric stabilizer 65 and the offset angle α , this combination causes the bottom-hole assembly to build angle at .58 degrees per 100 feet. As a result, the system, when being utilized in a directional drilling mode, will build angle at .88 degrees per 100 feet. It can be seen that prior to putting this bottom-hole assembly into the ground, its performance in the directional mode can be fairly accurately predicted.

Looking now at bottom-hole assembly B, we can see that changing just 2 parameters creates a different directional characteristic. Bottom-hole assembly B has an offset angle α of half a degree and utilizes a bearing stabilizer 65 which is undersized by .057 inches. All the other parameters remain the same. The four stabilizers thereby provide a bottom-hole assembly which drops angle at .59 degrees per 100 feet. The bent

SUBSTITUTE SHEET

-16-

housing and bearing stabilizer causes the bottom-hole assembly to build angle by .75 degrees per 100 feet. The resulting overall system will therefore build angle by .16 degree per 100 feet when in the directional mode.

5 Referring to bottom-hole assembly C, again we change the offset angle α and the undersize differential of the bearing stabilizer 65. The angle α is chosen to be 3/4 of a degree and the bearing stabilizer 65 is undersized by .282 inches. As a result, the

10 characteristic of the stabilizer string is to drop angle by 1.48 degree per 100 feet, up to 1.49 angle per 100 feet, if the weight on bit is increased from 10,000 pounds. The bent housing and bearing stabilizers 65 will build angle at .92 degrees per 100 feet, up to .95

15 degrees per 100 feet if the weight on bit is increased to 40,000 pounds. Accordingly, the combination results in a directional bottom-hole assembly which will drop angle at .56 degrees per 100 feet.

Figure 5 illustrates three more bottom-hole

20 assemblies D, E and F. The bottom-hole assembly D, utilizes an offset angle α of a quarter of a degree and stabilizer spacing of L1 - 4-1/4 feet, L2 - 31 feet, L3 - 35 feet, and L4 - 45 feet, with an undersized diameter differential Δd of .032 for each of the concentric

25 stabilizers. This system is shown to build angle at 1.01

-17-

degrees per 100 feet up to 1.22 degrees per 100 feet as the weight on bit is increased to 40,000 pounds. The bent housing and bearing stabilizer 65 will cause the bottom-hole assembly to build angle by 1.27 degrees per 100 feet up 1.50 degrees per 100 feet as the weight-on bit is increased to 40,000 pounds. As a result, the bottom-hole assembly D will build angle from 2.28 degrees per 100 feet to 2.72 degrees per 100 feet depending upon the amount of weight-on bit.

10 The bottom assembly E is shown as utilizing an offset angle α of $1/2$ a degree and a Δd for bearing stabilizer 65 of .157 inches. All other variables remain the same. The stabilizer section of the bottom-hole assembly, as a result, will build angle at .14 degrees per 100 feet up to .33 degrees per 100 feet, depending upon the weight on a bit. The bent housing portion of the bottom-hole assembly will tend to build angle at 1.44 degrees per 100 feet up to 1.68 degrees per hundred feet depending on the weight on bit. The overall system will tend to drill directionally at 1.58 degrees per 100 feet up to 2.01 degrees per 100 feet depending upon the weight on the bit.

Looking now at system F, the bent housing used has an offset angle of $3/4$ of a degree and a d undersized bearing stabilizer 65 at .282 inches. All

-18-

other variables remain the same. As a result, the stabilizer section will drop angle from .72 degrees per 100 feet to .56 degrees per 100 feet depending on weight on bit. The bent housing will tend to build angle at 5 1.61 degree per 100 feet to 1.87 degree per 100 feet. The combination will drill directionally to build angle of .89 degrees per 100 feet up to 1.31 degrees per 100 feet depending upon weight on bit.

The particular down-hole system chosen, A, B, C, 10 D, E, or F, or any other system, will depend upon a proposed well plan directed by the customer. A typical well plan is shown in Figure 6 where the borehole is drilled vertically for approximately 1,850 feet from the surface 77, at which point it is kicked off and then 15 drilled at a certain angle to a vertical depth of 6,300 feet and an angle depth of 7,970 feet.

The bottom-hole assembly of the present invention is assembled at the surface with the concentric stabilizers located at distances L1, L2, L3, and L4, 20 having a differential undersize as specified, and a specific offset angle α to accomplish the kickoff at 1,850 feet and follow the well plan as shown in Figure 6. For straight hole drilling from ground level 77 to the 1,850 foot depth, both the down-hole motor and the 25 drillstring are rotated together. Rotation of the

-19-

drillstring nullifies the directional characteristic built-in to the down-hole assembly. At the 1,850 foot mark, where kick-off is required, only the down-hole motor is rotated causing the down-hole assembly to take on its full directional characteristic, kick-off and follow the well plan. Once complete kickoff is established, the drillstring can again be rotated if the down-hole assembly starts to build too great an angle. In this way the down-hole assembly is steered to its target. The result, as the curves of Figure 6 illustrate, is that the gyrosurvey data 83 is almost overlaying the proposed well plan 79.

The actual results of the bottom-hole assembly of the present invention were surprising as is evident from this example. The well plan required that the downhole assembly maintain 43 degrees per 56 feet of deviation angle from a depth of 3,077 feet to a depth of 7,216 feet in an 8-1/2 inch hole. The bottom-hole assembly of the present system was used with an offset angle of 1/2 degree. The average rate of penetration of the bottom-hole assembly was 103.5 feet per hour. The rate of penetration while drilling was 147 feet per hour which reached up to 330 feet per hour. The system hit the target 6 feet under average angle and 40 feet to the right. Total cost savings was \$112,500 as a result of being 3/4 of a day ahead of schedule.

-20-

As can be seen from this example, by taking a systems approach to the bottom-hole assembly to be used in directional drilling and specifically designing the bottom-hole assembly for a particular well plan in the manner illustrated and according to the present invention, the ROP can be increased considerably, resulting in significant savings per well.

-21-

CLAIMS

What is claimed is:

1. A system for controlled directional drilling of a borehole wherein the drillstring is rotatable from the surface, comprising:
 - a drill bit;
 - 5 a bent housing bent from the centerline of the drillstring by a predetermined angle α ;
 - a down-hole motor connected to said drill bitthrough said bent housing, thereby offsetting the centerline of the drill bit face from the
 - 10 borehole centerline by an angle α ;
 - a plurality of concentric stabilizers located at preselected locations along the drillstring, wherein a first stabilizer is located a preselected distance from the bit,
 - 15 between the bit and the bent housing, a second stabilizer is located a preselected distance from the first stabilizer on the up-hole side of the motor, and a third stabilizer is located a preselected distance from the second stabilizer
 - 20 on the drillstring, each said stabilizer having a preselected diameter with respect to the hole diameter; and

-22-

whereby said system follows a curved
drilling path defined by the angle α of the bent
housing and the diameter and location of the
25 concentric stabilizer when only the down-hole
motor is rotated, and said system follows a
straight drilling path along the centerline of
the borehole when both the down-hole motor and
30 the drillstring are rotated simultaneously.

2. The system for controlled directional
drilling of a borehole of Claim 1 further comprising a
bearing housing connected between the drill bit and said
bent housing wherein the drive shaft of said down-hole
5 motor is concentrically located and connected to drive
said drill bit, said first concentric stabilizer being
located at said bearing housing.

3. The system for controlled directional
drilling of a borehole of Claim 1 further comprising a
fourth concentric stabilizer located a preselected
distance on the drillstring from the third stabilizer.

-23-

4. The system for controlled directional drilling of a borehole of Claim 2 further comprising a bearing housing connected between the drill bit and said bent housing wherein the drive shaft of said down-hole motor is concentrically located and connected to drive said drill bit, said first concentric stabilizer being located at said bearing housing.

5. A method for controlled directional drilling of a borehole, comprising the steps of:

assembling above ground the down-hole assembly based on the proposed well plan by:

- a) choosing a bent housing having a fixed bend angle α ;
- b) connecting the drill bit to a down-hole motor through the bent housing;
- c) choosing a plurality of concentric stabilizers of a predetermined diameter for location along the drillstring;

-24-

15 d) placing at least three concentric stabilizers along the drillstring with the first one a preselected distance from the bit between the bit and the bent housing, the second one a preselected distance from the first stabilizer on the up-hole side of the motor, and the third one a preselected distance from the second one on the drill-string;

20 lowering the assembly into the hole; orienting the drillstring to point the bent housing in the direction the borehole should travel;

25 rotating the down-hole motor only when it is desired to cause the borehole to travel along the curve determined by the assembly; and

30 rotating both the down-hole motor and the drill-string when it is desired to cause the borehole to travel along a straight path.

AMENDED CLAIMS

[received by the International Bureau on 2 March 1987 (02.03.87);
original claims 1-5 amended; new claims 6-19 added (6 pages)]

1. An improved system for controlled directional and straight drilling of a borehole wherein the entire drillstring is rotatable from the surface, including a bottomhole assembly comprised of a drill bit connected to the output shaft of a downhole motor for independent rotation from the drillstring, said motor connected at its uphole end to the drillstring, the improvement in the bottomhole assembly, comprising:

a first, concentric stabilizer, having a preselected diameter slightly smaller than the diameter of the borehole, mounted between the drill bit and motor at a preselected distance from the bit around the output shaft of said downhole motor, said shaft being concentrically located therein;

a bent motor housing connected to the downhole end of said downhole motor that has a bend from its geometric center at a predetermined angle α at its downhole end, thereby offsetting the centerline of said first stabilizer and the centerline of the drill bit face from the borehole centerline by said angle α ;

a second concentric stabilizer, having a preselected diameter slightly smaller than the diameter of the borehole, mounted at a preselected distance from said first concentric stabilizer on the drillstring, said drillstring being concentrically located therein; and

25 a third concentric stabilizer, having a preselected diameter slightly smaller than the diameter of the borehole, mounted at a preselected distance from said second concentric stabilizer on the drillstring, said drillstring being concentrically located therein;

30 wherein the angle α of the bend in the motor housing, and the diameter and placement of the concentric stabilizers are determined by the desired path of the borehole to be drilled, said system drilling a curved borehole when only the downhole motor is activated, and drilling a straight borehole
35 when the downhole motor is activated and both the drillstring and downhole motor housing are rotated.

2. The system for controlled directional and straight drilling of a borehole of Claim 1 further comprising a bearing housing connected between the drill bit and the downhole end of said downhole motor housing, the drive shaft
5 of said downhole motor being concentrically located therein and connected to drive said drill bit, said first concentric stabilizer being mounted on said bearing housing at a distance less than five feet from the face of the drill bit.

3. The system for controlled directional and straight drilling of a borehole of Claim 1 further comprising a fourth concentric stabilizer located a preselected distance on the drillstring from the third stabilizer.

4. The system for controlled directional and straight drilling of a borehole of Claim 2, wherein the bend angle α of the downhole motor housing is one degree or less.



5. A method for controlled directional and straight drilling of a borehole, according to a predetermined well plan, utilizing a bottomhole assembly connected to a drillstring comprising a drill bit connected for independent rotation from said drillstring to the output shaft of a downhole motor having its uphole side connected to the drillstring, comprising the steps of:

a. selecting the placement and diameter of three concentric stabilizers on the drillstring as follows, the first concentric stabilizer being placed less than five feet from the face of the drill bit and having a slightly smaller diameter than the borehole, the second concentric stabilizer being placed a predetermined distance from the first stabilizer and having a slightly smaller diameter than the borehole, the third concentric stabilizer being placed a predetermined distance from the second stabilizer and having a slightly smaller diameter than the borehole;

b. selecting a predetermined weight on bit; whereby the assembled concentrically stabilized drillstring with the selected weight on the bit exhibit a certain build angle or drop angle characteristic;

c. selecting a bend angle under two degrees;

d. placing the bend angle in the drillstring between the downhole motor and the drill bit on the uphole side of said first concentric stabilizer;

whereby said first concentric stabilizer and said selected bend angle exhibit a certain build angle

characteristic, the concentrically stabilized drillstring with
the selected weight on bit and the selected bend angle
30 combining to form an interacting bottomhole assembly having a
certain build angle or drop angle characteristic uniquely
suited to the well plan; and

e. steering said unique downhole assembly by:

1) turning the drillstring to point the bend
35 in the drillstring and the bit in the direction the borehole
should follow;

2) activating the downhole motor while keeping
the drillstring stationary when it is desired to drill along a
curved path, as determined by the bend angle and first
40 concentric stabilizing combination;

3) rotating the drillstring and downhole motor
while activating the downhole motor to turn the drill bit when
it is desired to drill along a straight path.

6. The system for controlled directional and
straight drilling of a borehole of Claim 1, wherein the bend
angle α of the downhole motor housing is about one-quarter of
one degree.

7. The system for controlled directional and
straight drilling of a borehole of Claim 1, wherein the bend
angle α of the downhole motor housing is about one-half of
one degree.

8. The system for controlled directional and
straight drilling of a borehole of Claim 1, wherein the bend
angle α of the downhole motor housing is about three-quarters
of one degree.

9. The system for controlled directional and straight drilling of a borehole of Claim 1, wherein said first concentric stabilizer is placed at four and one-quarter feet from the face of the drill bit.

10. The system for controlled directional and straight drilling of a borehole of Claim 9, wherein said second concentric stabilizer is placed at thirty-one feet from said first concentric stabilizer.

11. The system for controlled directional and straight drilling of a borehole of Claim 10, wherein said third concentric stabilizer is placed at forty-five feet from said second concentric stabilizer.

12. The system for controlled directional and straight drilling of a borehole of Claim 10, wherein said third concentric stabilizer is placed at thirty-five feet from said second concentric stabilizer.

13. The system for controlled directional and straight drilling of a borehole of Claim 6, or Claim 7, or Claim 8, wherein said first concentric stabilizer is placed at four and one-quarter feet from the face of the drill bit.

14. The system for controlled directional and straight drilling of a borehole of Claim 13, wherein said second concentric stabilizer is placed at thirty-one feet from said first concentric stabilizer.

15. The system for controlled directional and straight drilling of a borehole of Claim 14, wherein said third concentric stabilizer is placed at forty-five feet from said second concentric stabilizer.

16. The system for controlled directional and straight drilling of a borehole of Claim 14, wherein said third concentric stabilizer is placed thirty-five feet from said second concentric stabilizer.

17. The system for controlled directional and straight drilling of a borehole of Claim 11 or Claim 12, wherein said first, second and third concentric stabilizers are .032 inches smaller than the borehole.

18. The system for controlled directional and straight drilling of a borehole of Claim 11 or Claim 12, wherein said first concentric stabilizer is .157 inches smaller than the borehole and said second and third
5 stabilizers are .032 inches smaller than the borehole.

19. The system for controlled directional and straight drilling of a borehole of Claim 11 or Claim 12, wherein said first concentric stabilizer is .282 inches smaller than the borehole and said second and third
5 stabilizers are .032 inches smaller than the borehole.

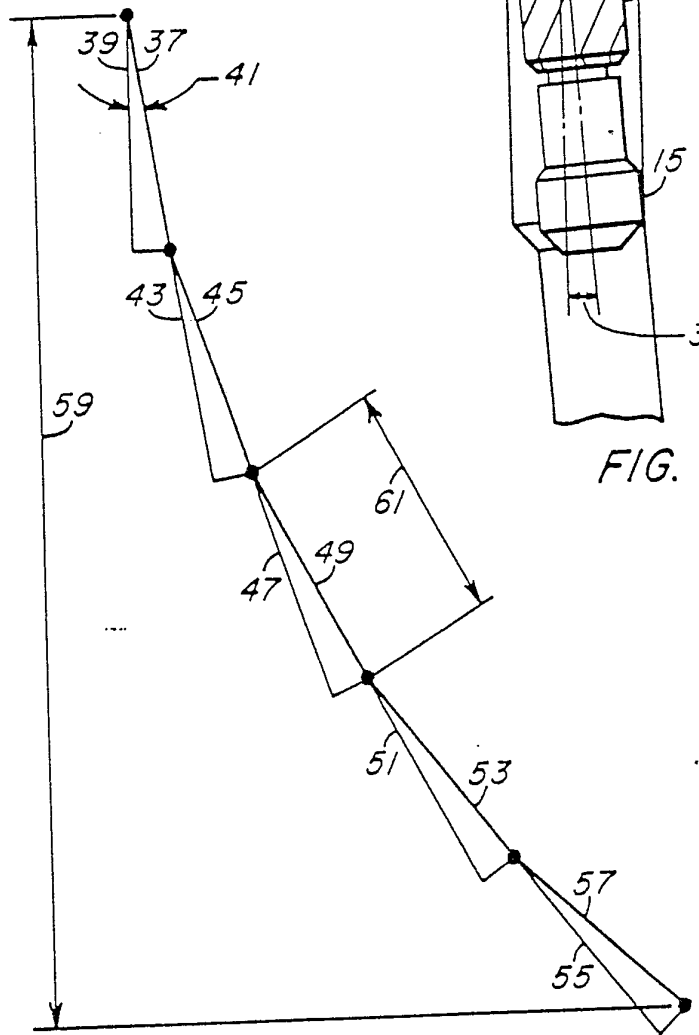
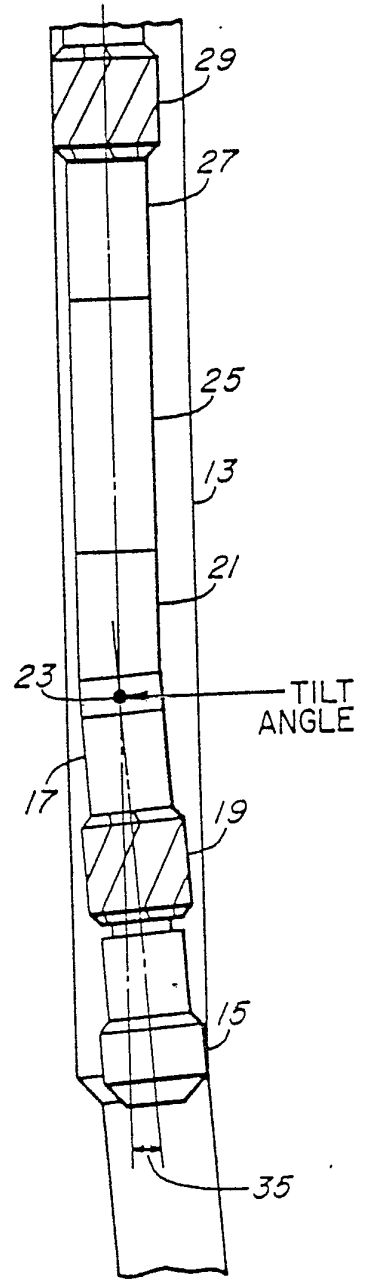
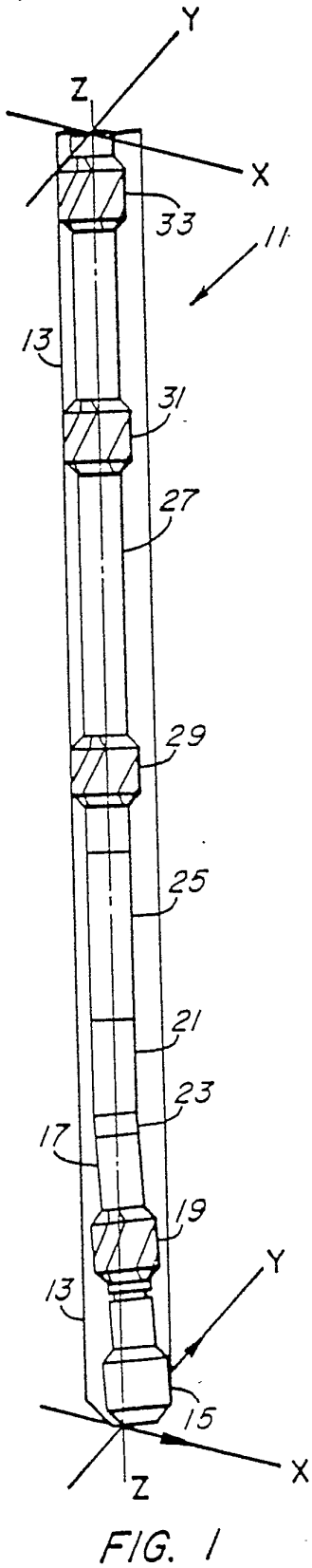

FIG. 2

FIG. 3



HOLE SIZE HOLE WASHOUT	A		B		C	
	12 1/4	12 1/4	12 1/4	12 3/8	12 1/4	12 1/4
	12 1/4	12 1/4	12 1/4	12 3/8	12 1/4	12 1/4
	$\alpha = 1/4^\circ$	$\alpha = 1/4^\circ$	$\alpha = 1/2^\circ$	$\alpha = 1/2^\circ$	$\alpha = 3/4^\circ$	$\alpha = 3/4^\circ$
	L4 35	Δd .032	L4 35	Δd .032	L4 35	Δd .032
	L3 45	Δd .032	L3 45	Δd .032	L3 45	Δd .032
	L2 31	Δd .032	L2 31	Δd .032	L2 31	Δd .032
	L1 4 1/4	Δd .032	L1 4 1/4	Δd .032	L1 4 1/4	Δd .032
	L1 - L4	L1 & BEND	L1 - L4	L1 & BEND	L1 - L4	L1 & BEND
WOB	.30°/100'	.58°/100'	-.59°/100'	.75°/100'	-1.48°/100'	.92°/100'
10K	.30°/100'	.58°/100'	-.59°/100'	.75°/100'	-1.49°/100'	.92°/100'
15K	.30°/100'	.58°/100'	-.59°/100'	.75°/100'	-1.49°/100'	.93°/100'
20K	.30°/100'	.58°/100'	-.59°/100'	.75°/100'	-1.49°/100'	.95°/100'
40K	.30°/100'	.58°/100'	-.59°/100'	.76°/100'	-1.49°/100'	.95°/100'

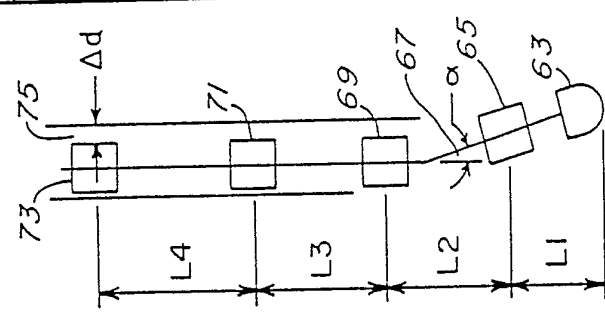

FIG. 4

HOLE SIZE HOLE WASHOUT	D			E			F				
	12 1/4	12 1/4	12 1/4	12 1/4	12 3/8	12 1/4	12 1/4	12 1/4	12 1/4	12 1/2	12 1/4
	$\alpha=1/4$	$\alpha=1/4$	$\alpha=1/4$	$\alpha=1/2$	$\alpha=1/2$	$\alpha=3/4$					
	L4 45	Δd .032									
	L3 35	Δd .032									
	L2 31	Δd .032									
	L1 4 1/4	Δd .032									
WOB	L1 - L4	L1 & α	L1 - L4	L1 & α	L1 - L4	L1 & α	L1 - L4	L1 & α	L1 - L4	L1 & α	L1 & α
10K	1.01°/100'	1.27°/100'	.14°/100'	1.44°/100'	1.4°/100'	1.44°/100'	1.4°/100'	1.44°/100'	1.44°/100'	1.61°/100'	1.61°/100'
15K	1.04°/100'	1.31°/100'	.16°/100'	1.48°/100'	.16°/100'	1.48°/100'	.16°/100'	1.48°/100'	1.48°/100'	1.65°/100'	1.65°/100'
20K	1.07°/100'	1.34°/100'	.19°/100'	1.51°/100'	.19°/100'	1.51°/100'	.19°/100'	1.51°/100'	1.51°/100'	1.69°/100'	1.69°/100'
40K	1.22°/100'	1.50°/100'	.33°/100'	1.68°/100'	.33°/100'	1.68°/100'	.33°/100'	1.68°/100'	1.68°/100'	1.87°/100'	1.87°/100'

FIG. 5

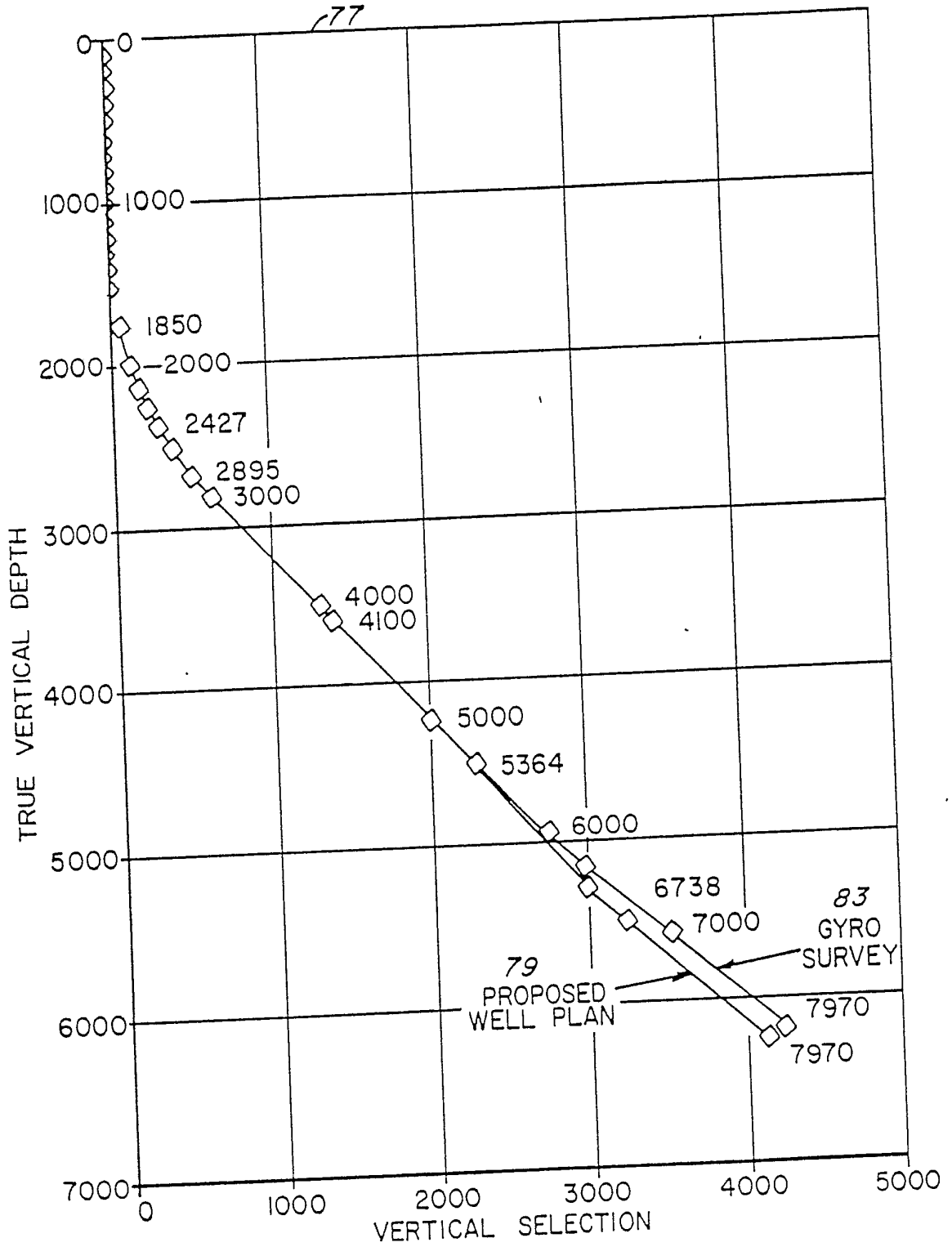
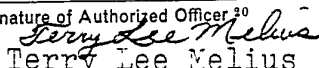

FIG. 6

INTERNATIONAL SEARCH REPORT

International Application No PCT/US86/01987

I. CLASSIFICATION OF SUBJECT MATTER (if several classification symbols apply, indicate all) ³		
According to International Patent Classification (IPC) or to both National Classification and IPC		
IPC (4) : E21B	7/06	U.S. CL. 175/61
II. FIELDS SEARCHED		
Minimum Documentation Searched ⁴		
Classification System	Classification Symbols	
U.S.	175/61,73,74,75,76,101	
Documentation Searched other than Minimum Documentation to the Extent that such Documents are Included in the Fields Searched ⁵		
III. DOCUMENTS CONSIDERED TO BE RELEVANT ¹⁴		
Category *	Citation of Document, ¹⁶ with indication, where appropriate, of the relevant passages ¹⁷	Relevant to Claim No. ¹⁸
Y	US, A, 4,577,701 (DELLINGER ET AL) 25 March 1986 , See the entire document.	(1,3,5)
Y	US, A, 4,067,404 (CRASE) 10 January 1978, See column 3-line 44 through column 4-line 14 and Figures 6-8.	(2,4)
Y	US, A, 3,563,323 (EDGECOMBE) 16 February 1971 See column 1-lines 37-57 and Figure 1.	(1,3,5,)
Y	FR, A, 2,369,412 (ALSTHOM-ATLANTIQUE) 30 June 1978, See the cover sheet and Figure 1.	(1,3,5)
Y	WORLD OIL, 1 August 1985 (T. BRASSFIELD and H. KARLSSON) Drill Faster, More Accurately With New Navigation System, pages 38-40, See Figure 1.	(1-5)
<p>* Special categories of cited documents: ¹⁵</p> <p>"A" document defining the general state of the art which is not considered to be of particular relevance</p> <p>"E" earlier document but published on or after the international filing date</p> <p>"L" document which may throw doubts on priority claim(s) or which is cited to establish the publication date of another citation or other special reason (as specified)</p> <p>"O" document referring to an oral disclosure, use, exhibition or other means</p> <p>"P" document published prior to the international filing date but later than the priority date claimed</p> <p>"T" later document published after the international filing date or priority date and not in conflict with the application but cited to understand the principle or theory underlying the invention</p> <p>"X" document of particular relevance; the claimed invention cannot be considered novel or cannot be considered to involve an inventive step</p> <p>"Y" document of particular relevance; the claimed invention cannot be considered to involve an inventive step when the document is combined with one or more other such documents, such combination being obvious to a person skilled in the art.</p> <p>"&" document member of the same patent family</p>		
IV. CERTIFICATION		
Date of the Actual Completion of the International Search ²	Date of Mailing of this International Search Report ²	
08 December 1986	02 JAN 1987	
International Searching Authority ¹	Signature of Authorized Officer ²⁰	
ISA/US	 Terry Lee Melius	