

J. T. MANGHAM.
Bale-Ties.

No. 152,138.

Patented June 16, 1874.

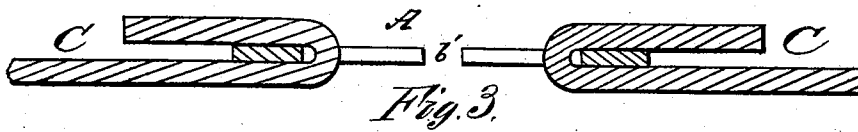
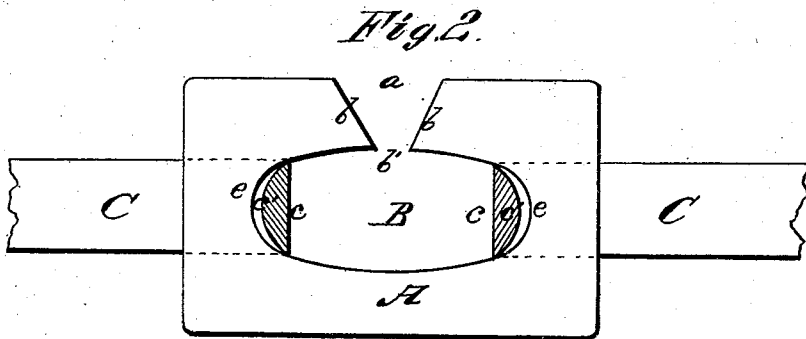
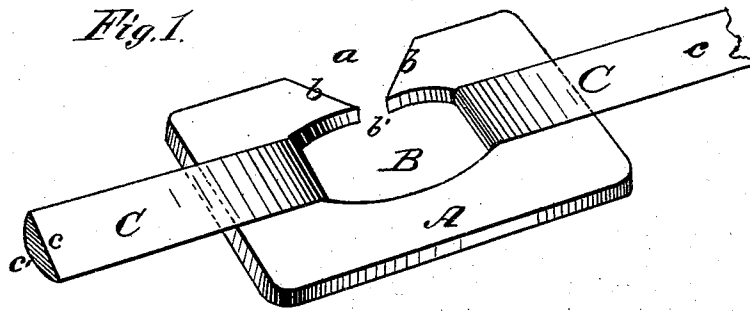

WITNESSES
W. A. Bates.
George E. Upham.

BY

INVENTOR
Josiah T. Mangham.
Chapman, Brewer & Co.

ATTORNEYS

UNITED STATES PATENT OFFICE.

JOSIAH T. MANGHAM, OF RAINEY'S CREEK, TEXAS.

IMPROVEMENT IN BALE-TIES.

Specification forming part of Letters Patent No. **152,138**, dated June 16, 1874; application filed April 18, 1874.

To all whom it may concern:

Be it known that I, JOSIAH T. MANGHAM, of Rainey's Creek, in the county of Coryell and State of Texas, have invented a new and valuable Improvement in Bale-Ties; and I do hereby declare that the following is a full, clear, and exact description of the construction and operation of the same, reference being had to the annexed drawings making a part of this specification, and to the letters and figures of reference marked thereon.

Figure 1 of the drawing is a representation of a perspective view of my bale-tie, and Fig. 2 is a plan view of the same. Fig. 3 is a sectional view.

This invention has relation to ties for cotton-bales, or other analogous purposes, where in a single plate or buckle is used, which is constructed with an open slot, forming two hooked ends, around which the ends of the bale-band are bent. The nature of my invention consists in a buckle having an open slot through it, which slot terminates in rounding ends and diverging edges, forming wedge-shaped receptacles for the band in combination with a band, which, in cross-section, presents a flat exterior surface and a convex interior surface, whereby the expansive force of the bale will be received by the strongest part of the band, and the ends of the latter prevented from displacement or casual detachment by reason of its wedging action in the buckle, induced by a different degree of convexity in the band and receiving ends of the buckle.

In the annexed drawings, A designates a buckle or tie of metal, having an open slot, B, with rounded ends *e e*; and an outwardly-flaring opening, *a*, which is formed by beveled edges *b b*, which opening serves to admit the ends C C of a metal band, used as a binder, of which the exterior surface *c* is flat, and the interior surface *c'* convex, as shown in cross-section, Fig. 2. The convex surface *c'* of the band is of such shape as will not make a close joint with the concavity of the rounded edge of the buckle A. There will be a vacant space between said surfaces, as shown in Fig. 2, when not under strain; but when tension is applied to a baled substance by removing

it from the compressor, then the rounded interior surface *e e* of the band is forced by expansion into a more or less close and intimate contact with the rounded edge of the buckle A, in proportion to the amount of strain or tension which said bale exerts in expanding, and causes thereby a strong wedge action.

The objection to using a single plate or buckles, with a flat metal band or strap, has heretofore been that when the bale of cotton, secured by flat metal bands, is released from the press an expansion, which is immediately observable, tightens the binders and puts the whole strain at once upon said binders or bands; but this strain in such case is not evenly distributed. It is chiefly exerted upon each edge of the band, from the fact that the material between the bands, not being so rigidly bound as it is immediately under the bands, bulges out, and by a subsequent expansion, which is due to absorption of moisture, continually increases the pressure upon the edges of said flat bands until said bands begin to tear across at some weak point, generally where they are bound around the buckle. Now, in my improved bale-tie I have constructed the bands in such manner that the surfaces thereof which are to be next the cotton shall be of a convex shape, applied to buckles of such a form that the surfaces of the band and the edges of the buckle shall not closely touch when not subjected to strain. When the bale thus secured is removed from a compressor, the violent strain caused by reaction and expansion is first received by the thickest and strongest part of the band, which is in the nature of an arch, and then gradually extended outward toward the edges thereof, thus constituting a safe and a durable tie, almost incapable of breaking from a violent strain produced by any accident in handling or in transportation. The surfaces *c' c* of the band C, and the edges *e e* of the buckle A, by their wedging action, which supervenes upon the application of any strain, will keep the said band firmly in place.

What I claim as new, and desire to secure by Letters Patent, is—

An open-slotted plate or tie, A, having an

outwardly-flaring opening, *a*, and the slot through which is terminated by round ends *e e*, in combination with a hoop or band, *C*, which, in cross-section, is flat on one side and convex on the interior surface, substantially as and for the purpose set forth.

In testimony that I claim the above I have

hereunto subscribed my name in the presence of two witnesses.

JOSIAH T. MANGHAM.

Witnesses:

GEO. M. BAIRNS,
S. B. RABY.