

(19) World Intellectual Property Organization  
International Bureau



(43) International Publication Date  
13 December 2001 (13.12.2001)

PCT

(10) International Publication Number  
**WO 01/93687 A1**

- (51) International Patent Classification<sup>7</sup>: **A21D 13/08**, A23P 1/08, A21C 9/06, A21D 8/02, A23G 3/00
- (74) Agents: **BOTTI, Mario** et al.; Botti & Ferrari S.r.l., Via Locatelli, 5, I-20124 Milano (IT).
- (21) International Application Number: PCT/EP01/06018
- (81) Designated States (*national*): AE, AG, AL, AM, AT, AU, AZ, BA, BB, BG, BR, BY, BZ, CA, CH, CN, CO, CR, CU, CZ, DE, DK, DM, DZ, EC, EE, ES, FI, GB, GD, GE, GH, GM, HR, HU, ID, IL, IN, IS, JP, KE, KG, KP, KR, KZ, LC, LK, LR, LS, LT, LU, LV, MA, MD, MG, MK, MN, MW, MX, MZ, NO, NZ, PL, PT, RO, RU, SD, SE, SG, SI, SK, SL, TJ, TM, TR, TT, TZ, UA, UG, US, UZ, VN, YU, ZA, ZW.
- (22) International Filing Date: 25 May 2001 (25.05.2001)
- (25) Filing Language: English
- (26) Publication Language: English
- (30) Priority Data: MI2000A001296 9 June 2000 (09.06.2000) IT
- (84) Designated States (*regional*): ARIPO patent (GH, GM, KE, LS, MW, MZ, SD, SL, SZ, TZ, UG, ZW), Eurasian patent (AM, AZ, BY, KG, KZ, MD, RU, TJ, TM), European patent (AT, BE, CH, CY, DE, DK, ES, FI, FR, GB, GR, IE, IT, LU, MC, NL, PT, SE, TR), OAPI patent (BF, BJ, CF, CG, CI, CM, GA, GN, GW, ML, MR, NE, SN, TD, TG).
- (71) Applicant (*for all designated States except US*): **BARILLA ALIMENTARE S.P.A.** [IT/IT]; Via Mantova, 166, I-43100 Parma (IT).
- (72) Inventors; and
- (75) Inventors/Applicants (*for US only*): **BURIANI, Ernesto** [IT/IT]; Via Federico Confalonieri, 10/3, I-42100 Reggio Emilia (IT). **SCHIARETTI, Enrico** [IT/IT]; Via Terracini, 35, I-43100 Parma (IT). **Terzoli, Corrado** [IT/IT]; Via Caldana, 27, I-20011 Corbetta (IT). **BUSCAGLINO, Jean-Paul** [IT/IT]; Via Barbero, 20, I-28100 Novara (IT).
- Published:**
- with international search report
  - before the expiration of the time limit for amending the claims and to be republished in the event of receipt of amendments

[Continued on next page]

(54) Title: A FILLED SNACK HAVING A WAFER OUTER ENVELOPE, A METHOD AND AN APPARATUS FOR THE PRODUCTION THEREOF.

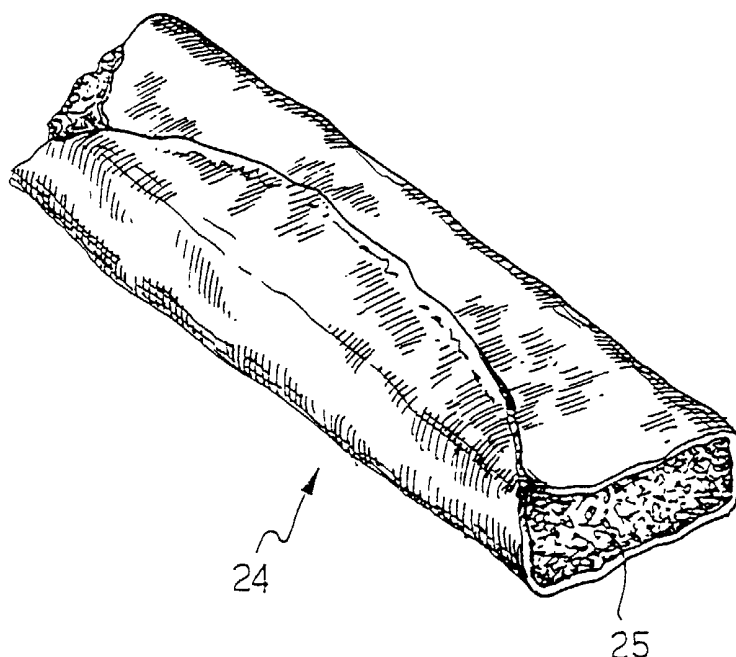

(57) Abstract: A filled snack (24) comprises a substantially straight tubular wafer (14h) of substantially rectangular cross-section, having a thickness of less than 3 mm for at least 80 % of its surface area and being filled with a creamy filling, which filling is substantially anhydrous and preferably sweet; this snack article is prepared by filling an envelope formed by folding over wafer laps on an apparatus (1) that comprises a forming die (3) and a bar-shaped plug (9).



WO 01/93687 A1



---

*For two-letter codes and other abbreviations, refer to the "Guidance Notes on Codes and Abbreviations" appearing at the beginning of each regular issue of the PCT Gazette.*

**“A filled snack having a wafer outer envelope, a method and an apparatus for the production thereof”**

**DESCRIPTION**

Field of Application

5           The present invention broadly pertains to the food industry.

          Specifically, the invention relates to a sweet snack comprising a filled wafer, as well as to a method and an apparatus for making it.

Prior Art

10           Wafers, or waffles, are widely utilized in the food industry to produce conical and tubular envelopes, or biscuits and the like, and are obtained by either of two methods. In a first method, a wafer is prepared by flash baking, in a baking oven or under a heated press platen, a batter having a high sugar content. The hot wafer is then rolled up into a conical or a cylindrical final form.

15           This forming step must be carried out promptly, while the wafer is still hot, as on cooling the wafer becomes brittle and is easily crumbled.

          In the second method, the wafer is molded from a batter incorporating a very small amount (not exceeding 5%) of or no sugar at all. This because a large proportion of sugar would make the wafer  
20           difficult to be removed from the mold. Wafers obtained by this method tend to be spongy in texture and lack the crisp character of wafers obtained by the first method.

          The term “wafer” should be understood hereinafter to indicate exclusively a wafer of the crisp variety to be obtained by the first of the  
25           above methods.

          A description of an industrial process for making crisp rolled-up wafers can be found in US Patent 4 624 855, for example.

          Rolled-up wafers prepared by the first of the above methods are specially suitable to produce ice-cream or whipped milk cream cones, by

- 2 -

reason of their crisp biscuit-like texture making a pleasant contrast to the flowing consistency of ice-cream or whipped cream.

Also known are tubular wafers, which are made by rolling up a wafer web into a spiral form about a cylindrical or prismatic core support. During the rolling operation, there occurs a partial overlapping of the web, so that the wall thickness of the tubular wafer is doubled in the region of overlap.

In an effort to produce ever new snack articles that would distinguish themselves from those currently available on the market (e.g., conventional snacks comprising sponge cake or puff pastry, or chocolate-based bars and the like), the Applicant set about to provide a snack article of adequate shelf-life at room temperature, which would duplicate the contrasting quality of the crisp/soft association that is typical of ice-cream cones incorporating a crisp wafer, and be adapted for carrying in one's pocket.

#### Summary of the Invention

The problem underlying the invention is that of providing a filled snack that would keep at room temperature for at least two months, have a creamy fill enclosed in a thin envelope of a crisp wafer, and be a suitable shape to fit in one's pocket.

The above problem could not be solved by just filling a wafer cone with any cream that would keep at room temperature, for the conical shape is inconvenient to accommodate in an individual's pocket.

On the other hand, an attempt to overcome this by using the aforementioned tubular wafers would result in the crisp/soft contrast of the envelope to the filling being nullified by too thick a wafer.

The problem underlying this invention has been solved by a filled snack, which comprises a substantially straight tubular wafer, of substantially rectangular cross-sectional shape, having a thickness of less than 3 mm for at least 80% of its surface area and being filled with a creamy filling.

The creamy filling is substantially anhydrous, preferably sweet,

- 3 -

and comprises sugars and fats. It may optionally incorporate such additional ingredients as cocoa, chocolate, hazel nuts, puffed cereals, etc..

5 The snack of this invention is obtained by a method that comprises the steps of:

- baking a batter to provide a wafer;

- laying said wafer, while still hot, onto a forming die provided with a straight groove along a predetermined axis x-x, said groove having a rectangular cross-sectional shape;

10 - driving said wafer into the groove by moving a bar-shaped plug of rectangular cross-section down into the groove, whereby two laps of the wafer are turned up from said forming die and set vertically;

15 - folding said turned-up wafer laps onto the bar-shaped plug to form a tubular wafer with a substantially rectangular cross-sectional shape;

- releasing the formed tubular wafer from said bar-shaped plug; and

- filling said tubular wafer with the filling.

20 Preferably, the tubular wafer is released by withdrawing the plug bar from the groove along the axis x-x.

Advantageously, the tubular wafer is filled as the bar-shaped plug is being withdrawn, using a filling dispenser housed within the bar-shaped plug.

25 This invention also relates to an apparatus implementing the method just described.

#### Brief Description of the Drawings

The apparatus and method of this invention will be further described with reference to the accompanying drawing figures, of which:

- 4 -

- Figure 1 is a perspective view of a filled snack according to the invention;

- Figure 2 is a top view of the filled snack shown in Figure 1;

- Figure 3 is a cross-sectional view of the filled snack, taken along  
5 line III-III in Figure 1;

- Figure 4 is a top plan view of a wafer;

- Figure 5 is a schematic perspective view of an apparatus for making the snack of Figure 1;

- Figure 6 is a schematic plan view of a detail of the apparatus  
10 shown in Figure 5;

- Figure 7 is a schematic elevation view of the apparatus shown in Figure 5; and

- Figures 8 to 11 are perspective views of a wafer at successive stages of the process for making it in accordance with the inventive  
15 method.

#### Detailed Description of the Invention

Referring to the accompanying drawings, an apparatus according to this invention is shown generally at 1.

The apparatus 1 comprises a frame 2 carrying a forming die 3.  
20 The forming die 3 is comprised of a flat horizontal surface 4 and a straight groove or flute 5 having a horizontal axis x-x. The groove 5 has a rectangular cross-sectional shape with vertical short sides, so that a bottom 6 and opposed vertical walls 7, 8 are defined therein.

It should be noted that the forming die 3 is constructed as two  
25 halves 3a and 3b that can be clamped together along a midline 3c of the bottom 6 and separated from each other a distance only slightly greater than the width of the bottom 6.

A bar-shaped plug 9 has an axis a-a lying in the same direction as the axis x-x parallel to the groove 5, the bar-shaped plug 9 being guided

- 5 -

on the frame 2 for movement along a vertical axis z-z. The bar-shaped plug 9 is tubular in shape with a hollow interior 9a, has a rectangular cross-sectional shape with vertical short sides, and can be shifted between an upper position above the groove 5 and a lower position into the groove 5.

The bar-shaped plug 9 has an underside 10, oppositely located sidewalls 11, 12, and a top side 13.

It should be noted that the rectangular cross-section of the bar-shaped plug 9 is slightly smaller than the rectangular cross-section of the groove 5. Accordingly, with the bar-shaped plug 9 lowered into the groove, a U-shaped gap remains between the groove bottom 6 and the plug underside 10, as well as between the groove sidewalls 7, 8 and the plug sidewalls 11, 12, the size of the gap being substantially equal to the thickness of a wafer 14. In practice, the gap will not exceed 3 mm.

A head 15 is guided for movement on the frame 2 to shift the plug 9 vertically.

Also mounted on the frame 2 are two slides 16 and 17 horizontally movable along a perpendicular axis y-y to the axis x-x. These slides locate on either sides of the groove 5 and are adapted to be moved in succession towards and over the groove 5. The slides 16 and 17 have thrust strips 18 and 19, respectively, mounted to face the groove by respective straight working edges 20 and 21 thereof.

The head 15 carries a heated pressure pad 22, which is movable in a guided fashion into positions, respectively removed from and closer to the groove, along the vertical axis z-z.

It should be noted that the bar-shaped plug 9 is mounted to the head 15 through the intermediary of a slide 23 that can be shifted horizontally along the axis x-x. Thus, the bar-shaped plug 9 can be moved from a position inside the groove to a position outside the groove.

A filling dispenser, not shown, is mounted in the hollow interior 9a of the bar-shaped plug 9, and is operated as the bar-shaped plug is moved from inside the groove to its position outside the groove.

- 6 -

The above apparatus 1 further includes a feeder means, not shown, for feeding one wafer 3 at a time onto the flat surface 4 of the forming die 3, in a position defined by the straight working edges 20 and 21, with the slides 16 and 17 moved away from the groove.

5 Preferably, the wafer 14 has a substantially circular shape, of a diameter D (equal 110 mm in the example), less a segment 14a included between a chord 14b and an arc 14c. The wafer 14 has a width dimension C measured to the chord 14b (in the example, 90 mm). When placed on the flat surface 4, the wafer 14 has the chord 14b in contact  
10 with the straight working edge 20.

The above apparatus 1 is then completed with a transport means, not shown, which may be of the belt type and is preferably formed, beneath the die 3, with pits for easier separation of the finished snack article.

15 The apparatus of this invention further comprises a drive means, not shown because consisting of conventional pneumatic or electric motors, for driving the aforementioned movable elements.

#### Detailed Description

20 The method of this invention will be illustrated by means of the following non-limitative Example.

#### **EXAMPLE**

The preparation of a wafer to provide the envelope for the filled snack article according to the invention will be described first.

25 Such a wafer can be prepared from a batter having the following composition by weight, in percent of the overall batter weight:

O-type flour	36.4%
Water	35.6%
Granulated sugar	18.2%
Egg yolk	3.6%

	- 7 -
Milk cream	3.6%
Powdered malt extract	1.5%
Coconut oil	0.7%
Powdered soy lecithin	0.2%
5 Ammonium bicarbonate	0.1%
Sodium bicarbonate	0.1%

The above ingredients are mixed into a batter. Metered batter quantities, of about 10 ml each, are poured onto heated wafer plates that have been brought to a temperature of 200°C, and are fashioned  
10 into their final form shown in Figure 4. After a baking time of 40 seconds, a wafer is obtained of substantially circular shape, as specified hereinabove, and approximately 1,5 to 2 mm thick. The wafer is immediately transferred onto the surface 4 (Figure 8) of the forming die 3, in the space between the straight working edges 20 and 21, with the  
15 chord 14b laid along the working edge 21, the bar-shaped plug 9 and pressure pad 22 being in their raised positions.

Directly after the wafer is placed onto the surface 4, the bar-shaped plug 9 is moved down to contact the wafer and drive it into the groove, with portions 14d, 14e and 14f of the wafer filling the gap  
20 between the vertical wall 7 and the sidewall 11, between the bottom 6 and the underside 10, and between the vertical wall 8 and the sidewall 12 (Figure 9).

At this stage, the wafer is forced into a U-shape, with laps 14g, 14c thereof set to project vertically upwards from the surface 4 of the  
25 forming die 3.

Thereafter, by causing the straight working edges 20 and 21 of the slides 16 and 17 to move towards the groove, first the lap 14g is folded over the top side 13 of the bar-shaped plug 9 (Figure 10), and then the lap or lunule 14c is folded over the top side 13 of the bar-shaped plug 9  
30 (Figure 11) and sealed to the lap 14g to form a tubular wafer 14h having a substantially rectangular cross-sectional shape.

At this stage, the slides 16 and 17 are moved back into their original positions, and the pressure pad 22, heated at about 150°C, is lowered to enhance the bond between the juxtaposed wafer laps.

The bar-shaped plug 9 is withdrawn along the axis x-x while the filling dispenser is operated to dispense a predetermined amount of filling into the tubular wafer 14h. Thereafter, the bar-shaped plug 9 is raised vertically and again shifted horizontally to return it to its position above the groove, in readiness for another cycle.

A snack article 24, complete with its filling 25, is presently released by separating the die halves 3a and 3b, and dropped onto the transport means for conveyance to further processing stations.

The above cycle is repeated by laying a new wafer onto the die, now cleared of the filled wafer.

The filling used for filling the folded wafer may be of several different types, but is preferably anhydrous and comprised mainly of fats.

In this example, the filling has the following composition:

Powdered sugar	49.8%
Hydrogenated coconut oil	20.9%
Powdered cocoa	14.0%
Cocoa paste	11.0%
Hazel nut paste	4.0%
Powdered soy lecithin	0.3%

The filling is prepared by mixing the above ingredients to homogeneity in a planetary mixer.

Before delivering them to a packaging station, the filled wafers are finished by having minced hazel nut adhere to the filling surface not covered by the enveloping wafer.

- 9 -

The resultant filled snack exhibits a degree of raggedness along the edges and at the folded wafer laps, effectively duplicating the appearance of such home-made preparations as pancakes or omelettes.

5 A major advantage of a snack article according to the invention is that the crisp/soft contrast effect sought is made inherent to an article that can fit conveniently in one's pocket.

- 10 -

### CLAIMS

1. A filled snack (24), comprising a substantially straight tubular wafer (14h), said wafer having a substantially rectangular cross-sectional shape and a thickness dimension of less than 3 mm for at least 80% of its surface area and being filled with a creamy filling (25).  
5
2. A filled snack article according to Claim 1, wherein said creamy filling (25) is substantially anhydrous and mainly comprises sugars and fats.
3. A method of making a snack (24) comprising a tubular wafer (14h)  
10 having a substantially rectangular cross-sectional shape and filled with a creamy filling (25), said method comprising the steps of:
  - baking a batter to provide a wafer (14);
  - laying said wafer (14), while still hot, onto a forming die (3) provided with a groove (5) extending along a predetermined axis (x-x), said groove  
15 having a rectangular cross-sectional shape;
  - driving said wafer (14) into the groove (5) by moving a bar-shaped plug (9) of rectangular cross-section down into the groove, whereby two laps (14c,14g) of the wafer are turned up from said forming die (3) and set vertically;
  - 20 - folding said turned-up wafer laps (14c,14g) onto the bar-shaped plug (9) to form a tubular wafer (14h) with a substantially rectangular cross-sectional shape;
  - releasing the formed tubular wafer (14h) from said bar-shaped plug (9); and
  - 25 - filling said tubular wafer (14h) with the filling (25).
4. A method according to Claim 3, wherein said tubular wafer (14h) is released by withdrawing the bar-shaped plug (9) from the groove (5) along said predetermined axis (x-x).
5. A method according to Claim 4, wherein said tubular wafer is

- 11 -

filled with the filling (25) while withdrawing the bar-shaped plug (9), by means of a filling dispenser housed within the bar-shaped plug (9).

6. An apparatus (1) implementing the method of Claim 3, comprising a frame (2) carrying a forming die (3) provided with a groove (5), said groove extending along a predetermined axis (x-x) and having a rectangular cross-sectional shape, a bar-shaped plug (9) having a parallel axis (a-a) to said predetermined axis (x-x) and a rectangular cross-sectional shape, said bar-shaped plug being movable along a vertical axis (z-z) perpendicularly to said predetermined axis (x-x) between an upper position above the groove (5) and a lower position into the groove (5).
7. An apparatus (1) according to Claim 6, further comprising two slides (16,17) guided for movement in the frame (2) along a perpendicular axis (y-y) to said axes (x-x, z-z) and shiftable in succession towards the groove (5) from respective positions removed from said groove.
8. An apparatus (1) according to Claim 7, further comprising a pressure pad (22) guided for movement in the frame (2) and shiftable towards the groove (5) along a vertical axis (z-z).
9. An apparatus (1) according to Claim 8, wherein said bar-shaped plug (9) is adapted to be shifted along said axis (x-x) for withdrawal from the groove (5).
10. An apparatus (1) according to Claim 9, wherein said bar-shaped plug (9) is of a tubular construction defining a hollow interior (9a).
11. An apparatus (1) according to Claim 10, comprising a filling dispenser located in said hollow interior (9a) and fixed to said bar-shaped plug (9).
12. A filled snack (24) according to Claim 1 and obtainable by the method of any of Claims 3 to 5.

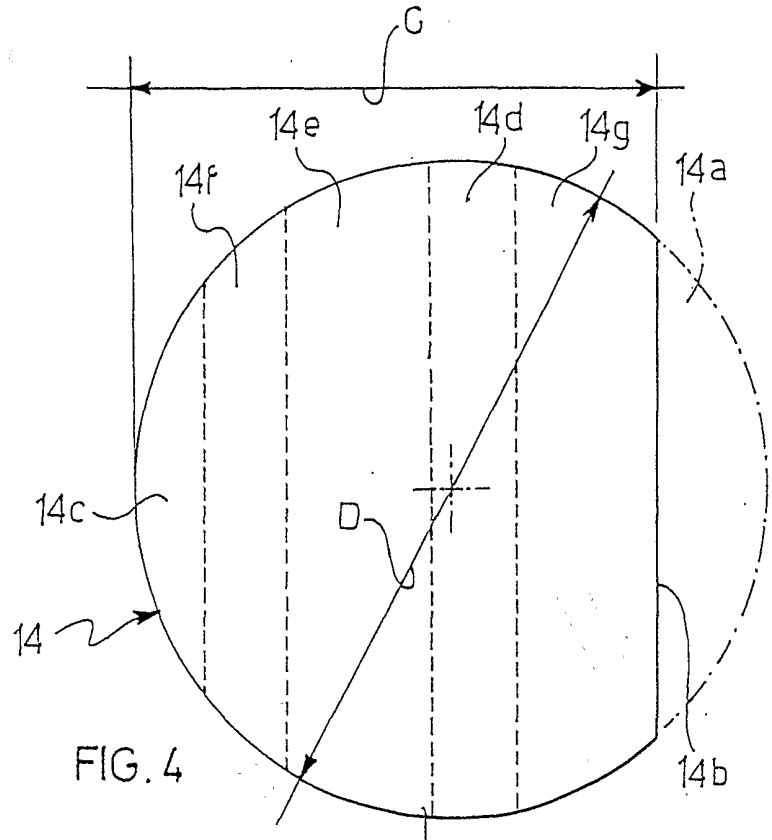
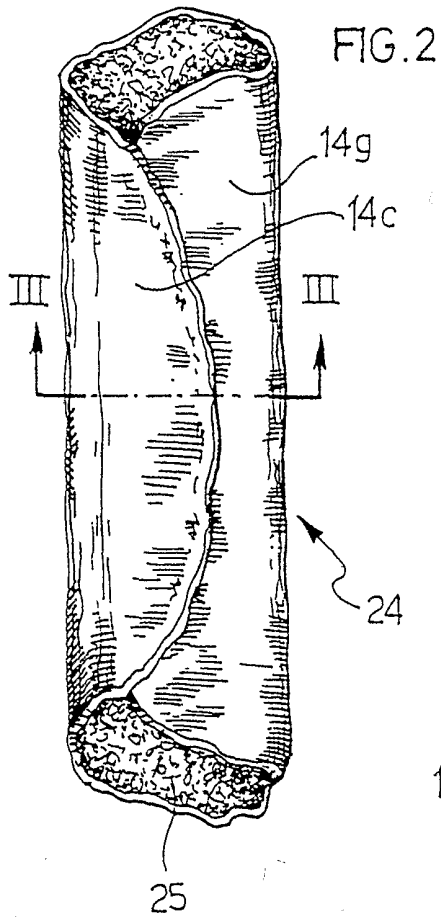
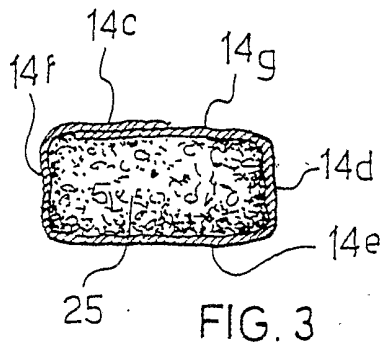
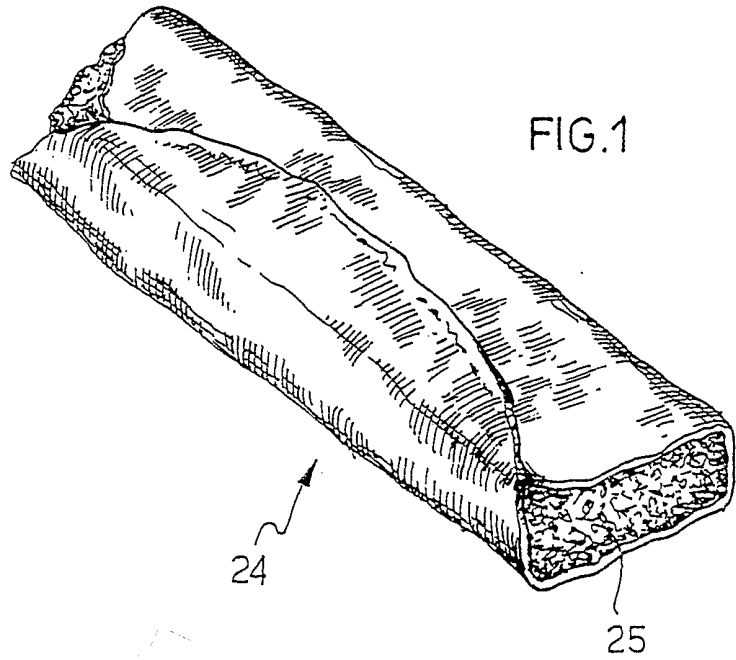



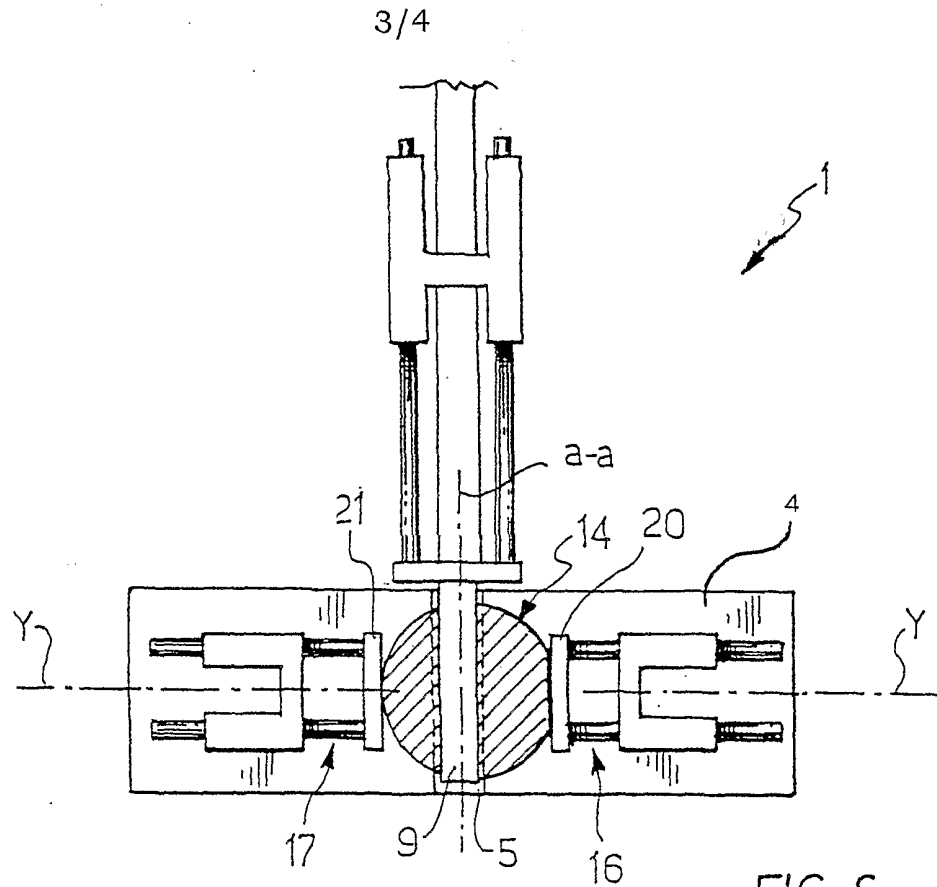

FIG. 6

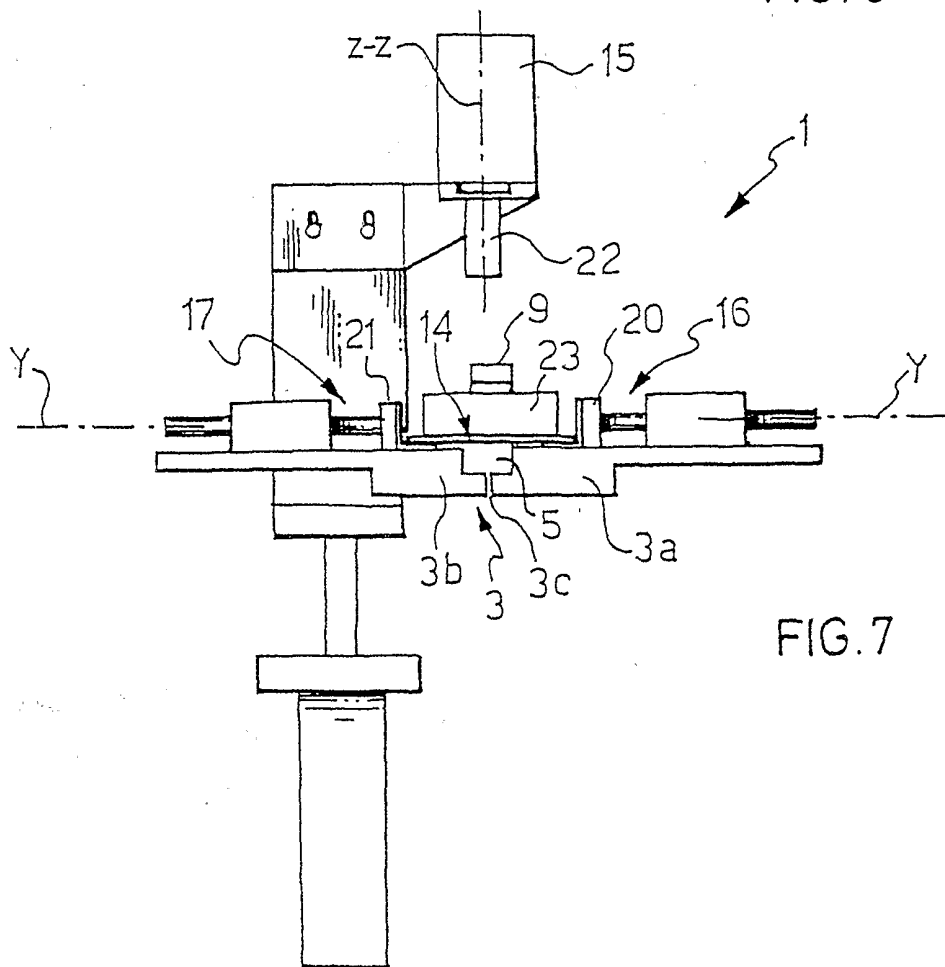
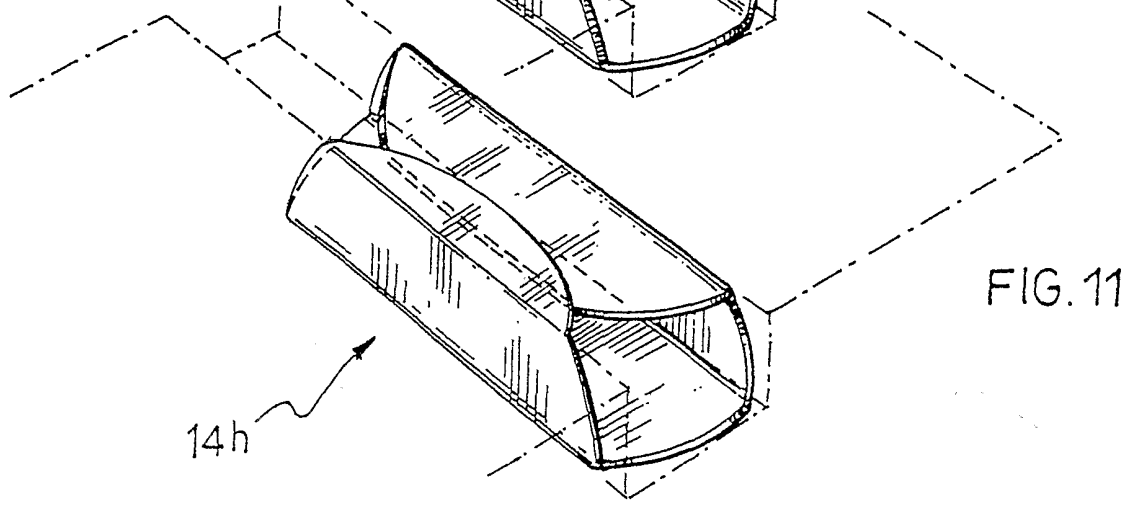
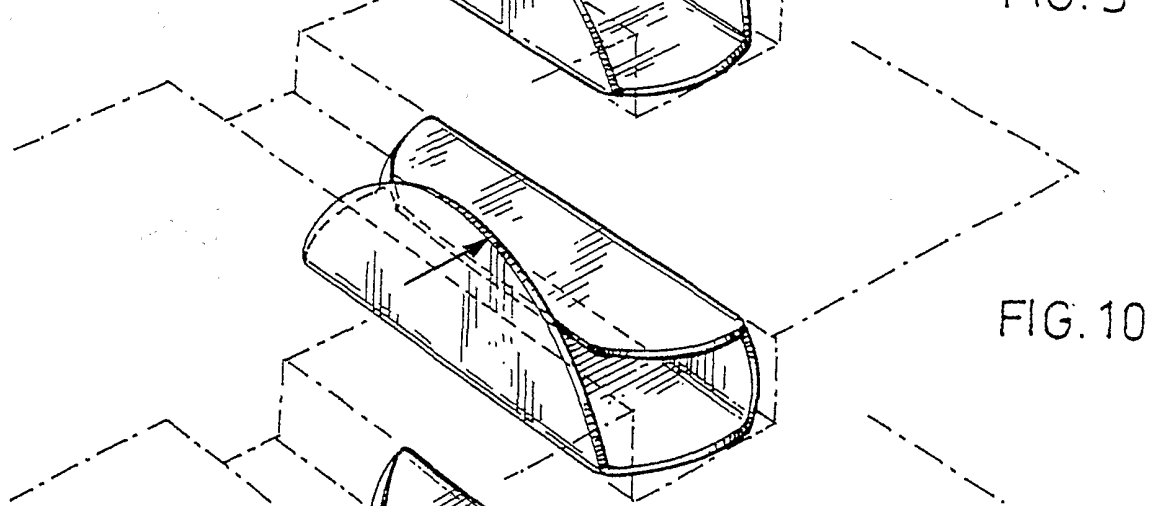
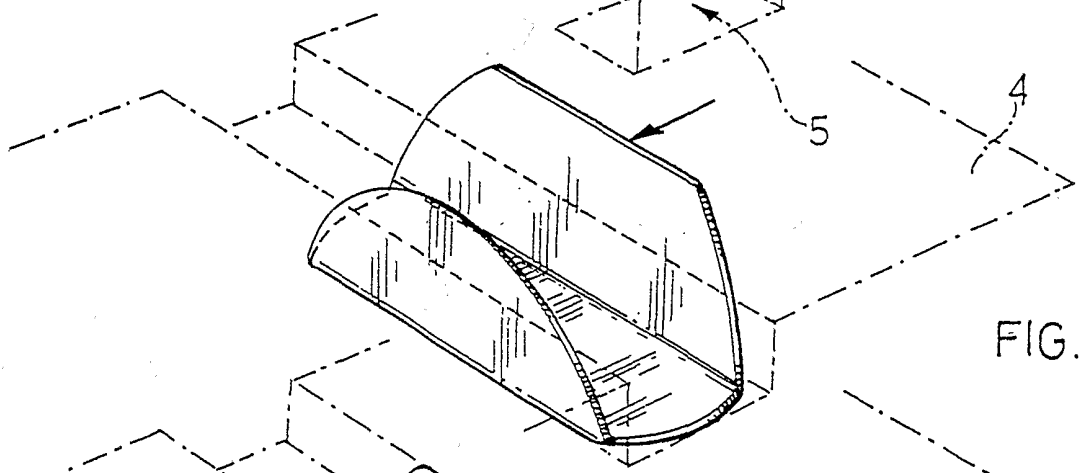
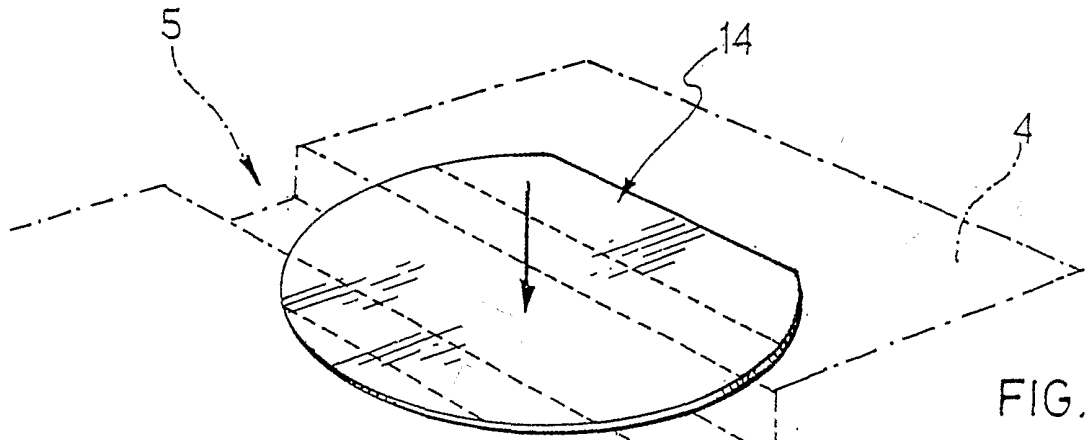

FIG. 7



INTERNATIONAL SEARCH REPORT

International Application No  
PCT/EP 01/06018

A. CLASSIFICATION OF SUBJECT MATTER

IPC 7 A21D13/08 A23P1/08 A21C9/06 A21D8/02 A23G3/00

According to International Patent Classification (IPC) or to both national classification and IPC

B. FIELDS SEARCHED

Minimum documentation searched (classification system followed by classification symbols)

IPC 7 A21D A23P A21C A23G

Documentation searched other than minimum documentation to the extent that such documents are included in the fields searched

Electronic data base consulted during the international search (name of data base and, where practical, search terms used)

WPI Data, EPO-Internal, PAJ, FSTA

C. DOCUMENTS CONSIDERED TO BE RELEVANT

Category °	Citation of document, with indication, where appropriate, of the relevant passages	Relevant to claim No.
X	EP 0 814 664 A (SORE MARTEC S A ; FERRERO OHG (DE); FERRERO SPA (IT)) 7 January 1998 (1998-01-07) claims 1-3 figures 1-4	1, 2, 12
X	EP 0 399 995 A (MARESI MARKENARTIKELVERTRIEB G) 28 November 1990 (1990-11-28) page 3, line 33-53 claims 1, 4, 8, 13 figure 1	1, 2, 12
A		3
	-/--	

Further documents are listed in the continuation of box C.

Patent family members are listed in annex.

° Special categories of cited documents :

- \*A\* document defining the general state of the art which is not considered to be of particular relevance
- \*E\* earlier document but published on or after the international filing date
- \*L\* document which may throw doubts on priority claim(s) or which is cited to establish the publication date of another citation or other special reason (as specified)
- \*O\* document referring to an oral disclosure, use, exhibition or other means
- \*P\* document published prior to the international filing date but later than the priority date claimed

- \*T\* later document published after the international filing date or priority date and not in conflict with the application but cited to understand the principle or theory underlying the invention
- \*X\* document of particular relevance; the claimed invention cannot be considered novel or cannot be considered to involve an inventive step when the document is taken alone
- \*Y\* document of particular relevance; the claimed invention cannot be considered to involve an inventive step when the document is combined with one or more other such documents, such combination being obvious to a person skilled in the art.
- \*Z\* document member of the same patent family

Date of the actual completion of the international search

24 October 2001

Date of mailing of the international search report

31/10/2001

Name and mailing address of the ISA

European Patent Office, P.B. 5818 Patentlaan 2  
NL - 2280 HV Rijswijk  
Tel. (+31-70) 340-2040, Tx. 31 651 epo nl,  
Fax: (+31-70) 340-3016

Authorized officer

Piret-Viprey, E

## INTERNATIONAL SEARCH REPORT

International Application No

PCT/EP 01/06018

C.(Continuation) DOCUMENTS CONSIDERED TO BE RELEVANT		
Category °	Citation of document, with indication, where appropriate, of the relevant passages	Relevant to claim No.
X	US 4 427 703 A (SCHULZ EBERHARD ET AL) 24 January 1984 (1984-01-24) figure 1 column 2, line 36-55	1,2,12
A	column 3, line 60-68 claims 1,6,22	3
X	US 3 867 559 A (HAAS FRANZ) 18 February 1975 (1975-02-18) figure 1 claim 1	1,2,12
X	WO 99 02042 A (NESTLE SA ;ROCHAT FLORENCE (CH); PFEIFER ANDREA M A (CH); LESENS C) 21 January 1999 (1999-01-21) page 9, line 16-30 example 5	1,2,12
P,X	EP 1 078 577 A (NESTLE SA) 28 February 2001 (2001-02-28) page 5, line 48-54 example 2 claims 23,26	1,2,12
E	FR 2 803 719 A (LU) 20 July 2001 (2001-07-20) claims 1,7 figures 1,5,7	1,2,12
A	US 4 439 124 A (WATANABE HIDEFUMI) 27 March 1984 (1984-03-27) figures 12,13,20A column 12, line 16-26 column 18, line 56 -column 19, line 43	3-11

## INTERNATIONAL SEARCH REPORT

Information on patent family members

International Application No

PCT/EP 01/06018

Patent document cited in search report		Publication date	Patent family member(s)	Publication date
EP 0814664	A	07-01-1998	CH 689505 A5	31-05-1999
			AT 188841 T	15-02-2000
			AU 5102596 A	02-10-1996
			CZ 9702861 A3	18-02-1998
			DE 69606284 D1	24-02-2000
			DE 69606284 T2	25-05-2000
			DK 814664 T3	08-05-2000
			EE 9700204 A	16-02-1998
			WO 9628035 A1	19-09-1996
			EP 0814664 A1	07-01-1998
			ES 2142050 T3	01-04-2000
			GR 3032998 T3	31-07-2000
			HU 9801833 A2	28-04-2000
			JP 11501810 T	16-02-1999
			NO 974254 A	15-09-1997
			PL 322256 A1	19-01-1998
			PT 814664 T	28-04-2000
			SK 122697 A3	04-02-1998
			US 6103279 A	15-08-2000
EP 0399995	A	28-11-1990	CA 2016961 A1	24-11-1990
			EP 0399995 A1	28-11-1990
			HU 55965 A2	29-07-1991
			NO 902286 A	26-11-1990
US 4427703	A	24-01-1984	AT 379293 B	10-12-1985
			AT 422081 A	15-05-1985
			AT 382499 B	25-02-1987
			AT 422181 A	15-08-1986
			AU 7599581 A	08-04-1982
			AU 7599681 A	08-04-1982
			BE 890614 A1	02-04-1982
			BE 890615 A1	02-04-1982
			BR 8106382 A	22-06-1982
			BR 8106383 A	22-06-1982
			CA 1168513 A1	05-06-1984
			CA 1168927 A1	12-06-1984
			CH 654983 A5	27-03-1986
			CH 654721 A5	14-03-1986
			DE 3139323 A1	24-06-1982
			DE 3139329 A1	09-06-1982
			DE 8128938 U1	19-05-1982
			DK 437781 A	04-04-1982
			DK 437981 A	04-04-1982
			ES 505996 D0	01-01-1983
			ES 8301597 A1	01-04-1983
			ES 505997 D0	01-03-1983
			ES 8304412 A1	01-06-1983
			ES 515491 D0	01-06-1983
			ES 8306570 A1	16-09-1983
			ES 515546 D0	01-06-1983
			ES 8306571 A1	16-09-1983
			FR 2491299 A1	09-04-1982
			FR 2491301 A1	09-04-1982
			FR 2491302 A3	09-04-1982
			GB 2084445 A ,B	15-04-1982
			GB 2084448 A ,B	15-04-1982
IT 1144889 B	29-10-1986			

## INTERNATIONAL SEARCH REPORT

Information on patent family members

International Application No

PCT/EP 01/06018

Patent document cited in search report	Publication date	Patent family member(s)	Publication date	
US 4427703	A	IT 1144890 B	29-10-1986	
		JP 57144944 A	07-09-1982	
		JP 57132843 A	17-08-1982	
		JP 58051741 B	18-11-1983	
		LU 83667 A1	07-05-1982	
		LU 83668 A1	07-05-1982	
		NL 8104529 A	03-05-1982	
		NL 8104530 A	03-05-1982	
		SE 8105808 A	04-04-1982	
		SE 457407 B	27-12-1988	
		SE 8105809 A	04-04-1982	
US 3867559	A	18-02-1975	NONE	
WO 9902042	A	21-01-1999	AU 8800298 A	08-02-1999
			BR 9811662 A	19-09-2000
			WO 9902042 A2	21-01-1999
			EP 0994656 A2	26-04-2000
EP 1078577	A	28-02-2001	EP 1078577 A2	28-02-2001
			JP 2001069919 A	21-03-2001
FR 2803719	A	20-07-2001	FR 2803719 A1	20-07-2001
US 4439124	A	27-03-1984	JP 1140054 C	24-03-1983
			JP 57022671 A	05-02-1982
			JP 57028541 B	17-06-1982
			JP 1140055 C	24-03-1983
			JP 57022672 A	05-02-1982
			JP 57028542 B	17-06-1982
			JP 1140056 C	24-03-1983
			JP 57022673 A	05-02-1982
			JP 57028543 B	17-06-1982
			JP 1154465 C	15-07-1983
			JP 57022674 A	05-02-1982
			JP 57044308 B	20-09-1982
			JP 1140057 C	24-03-1983
			JP 57022675 A	05-02-1982
			JP 57028544 B	17-06-1982
			JP 1140058 C	24-03-1983
			JP 57022676 A	05-02-1982
			JP 57028545 B	17-06-1982