

No. 777,059.

PATENTED DEC. 6, 1904.

J. H. PETROSKEY.

FLOOR RACK.

APPLICATION FILED MAY 26, 1903.

NO MODEL.

2 SHEETS—SHEET 1.

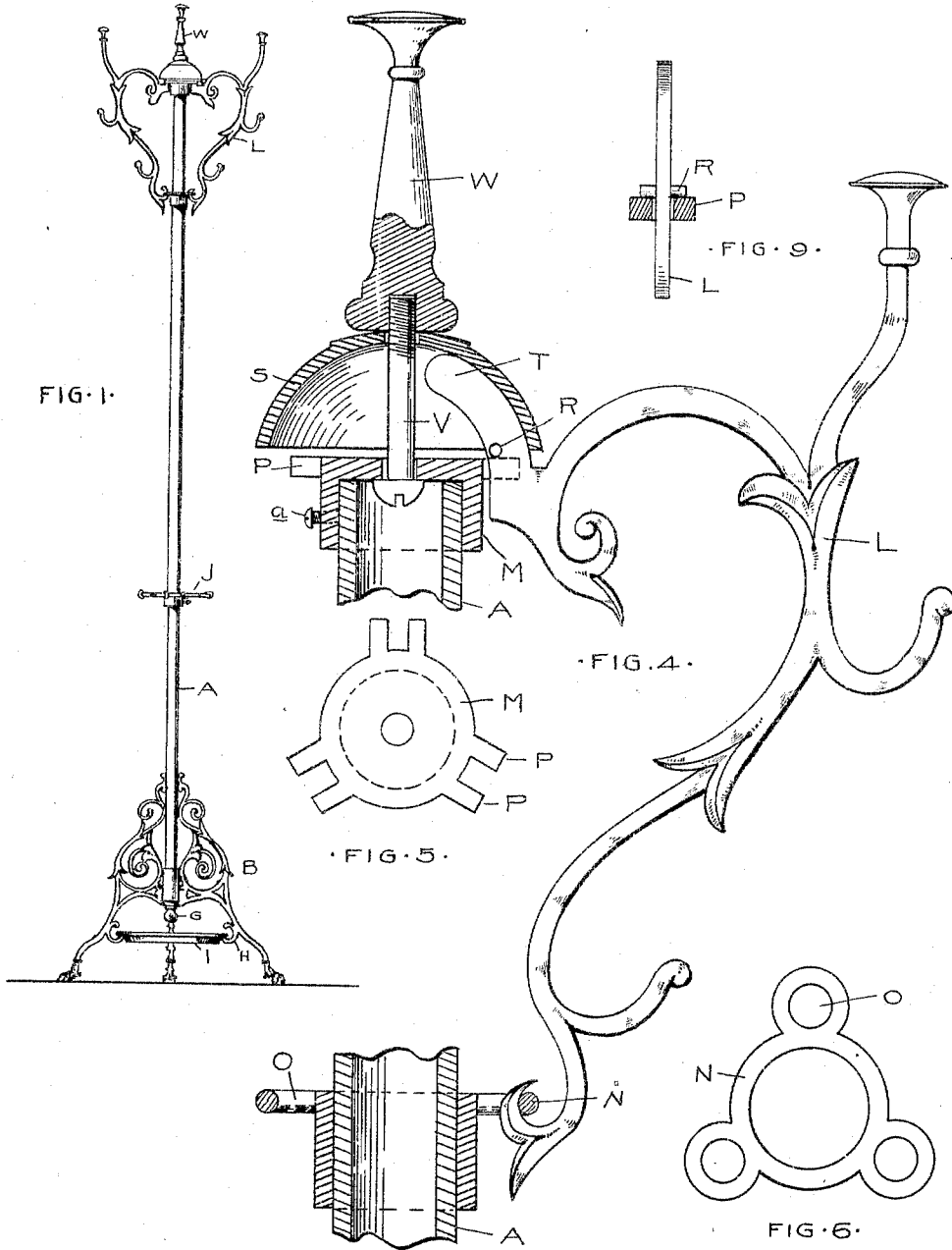

WITNESSES

*Wm. A. Green*  
*B. Smith*

INVENTOR

JOHN H. PETROSKEY.

BY

*James Whitmore* ATT'Y.

No. 777,059.

PATENTED DEC. 6, 1904.

J. H. PETROSKEY,  
FLOOR RACK.

APPLICATION FILED MAY 26, 1903.

NO MODEL.

2 SHEETS—SHEET 2.

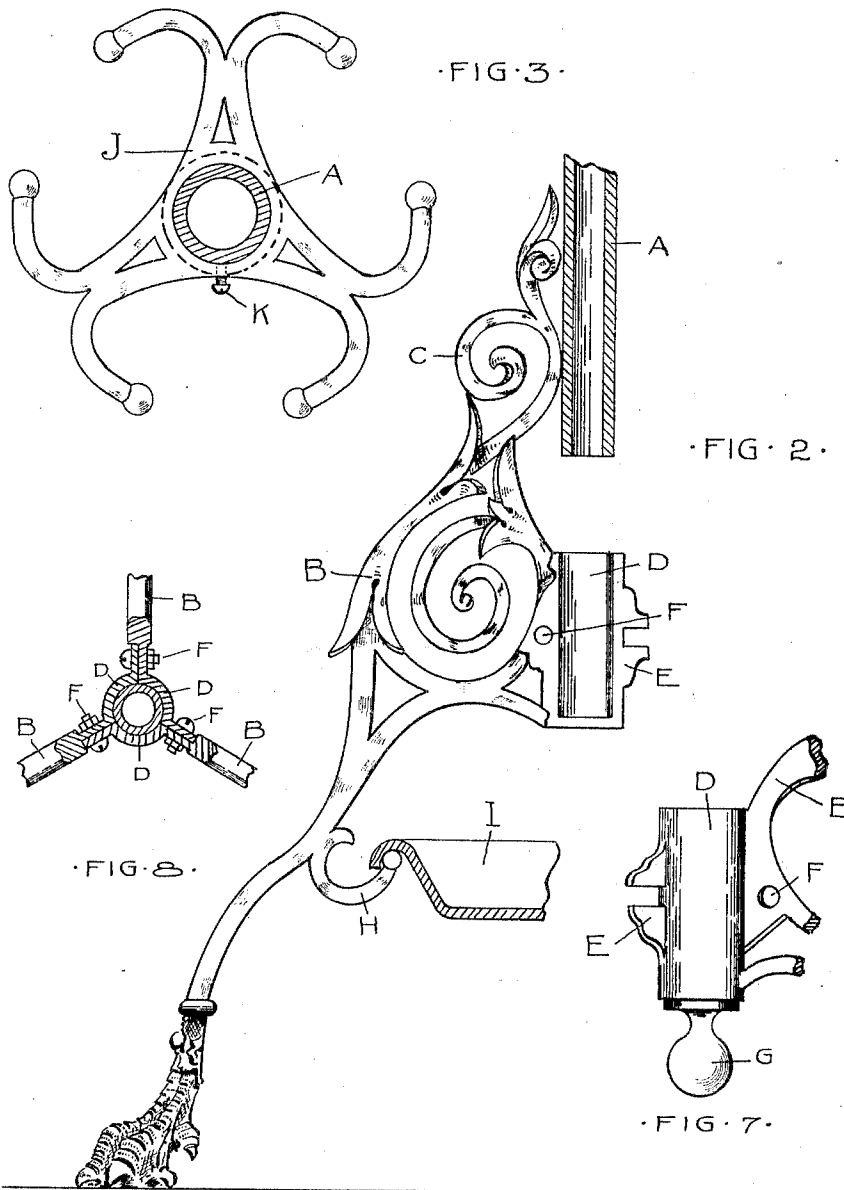

WITNESSES

*Geo. H. Cooper*  
*B. Smith*

INVENTOR

JOHN H. PETROSKEY.

BY *James Whittemore* ATT'Y.

# UNITED STATES PATENT OFFICE.

JOHN H. PETROSKEY, OF DETROIT, MICHIGAN, ASSIGNOR TO AMERICAN METALLIC FURNITURE COMPANY, OF DETROIT, MICHIGAN, A CORPORATION OF MICHIGAN.

## FLOOR-RACK.

SPECIFICATION forming part of Letters Patent No. 777,059, dated December 6, 1904.

Application filed May 26, 1903. Serial No. 158,833. (No model.)

To all whom it may concern:

Be it known that I, JOHN H. PETROSKEY, a citizen of the United States, residing at city of Detroit, in the county of Wayne and State of Michigan, have invented certain new and useful Improvements in Floor-Racks, of which the following is a specification, reference being had therein to the accompanying drawings.

My invention relates to improvements in hat, coat, and umbrella racks; and the objects of my invention are to provide a rack that shall be simple and easy to construct, easily taken apart and assembled, and that will be strong and rigid after being set up. I attain these objects by the construction illustrated in the accompanying drawings, in which—

Figure 1 is a general view of the rack. Fig. 2 is a side view of one of the legs, showing the attached segment of the socket for the standard. Fig. 3 is a plan of the umbrella-holder. Fig. 4 is a side view of the hat and coat holder, showing also the supporting parts for the same in section. Fig. 5 is a plan of the cap. Fig. 6 is a plan of the guide-ring. Fig. 7 is a detail of the segment of the socket; and Fig. 8 is a plan of the socket, the standard being shown in section. Fig. 9 is an elevation of pin R.

Similar reference characters refer to like parts throughout the several views.

The central upright standard A is supported by the legs B, each of which is provided with an upwardly-extending part C, resting against and assisting to support the standard A. Each leg has a segmental part D of such shape that when the legs are assembled the segments collectively form a socket for the standard. The parts are secured together by means of bolts passing through the aperture F of one piece and between the lugs E of the adjacent piece. The socket thus formed is slightly smaller than the standard, so that when the nuts on the bolts are screwed up the standard will be firmly held in the socket. The depending ball G may be attached to one part of the socket or be supported in any other desirable manner.

Just below the socket are the hooks H, one

on each leg, supporting the drip-pan I. Supported by the standard A is the umbrella-holder J, which is attached to the standard by the screw K.

The hat and coat hooks or holders L are supported by the cap-piece M, revoluble on the top of the standard A, and their lower ends are guided by the ring N. The supports are first hooked into the loops O of this guide-ring and then placed between the lugs P of the cap-piece, being supported by the pins R, resting on said lugs. The cover S engages projecting curved fingers T on the holders, preventing them from moving outward, while the pins R prevent the fingers slipping off the lugs. The cover S is held down by the bolt V, which passes up through the cap-piece M and the cover S and is engaged by the central upright piece W, which is extended upward, as shown in Fig. 1. The hat and coat holders, together with the cap-piece and ring N, may be revolved around the central standard or by means of a set-screw *a* may be held against rotation, as may be desired.

Having now described my construction, what I claim as my invention, and desire to secure by Letters Patent, is—

1. In a floor-rack, the combination of legs, a segment of a socket carried by each leg, said segments being secured together for forming a socket, an upright standard securely held by and in said socket, means at the lower end of the socket upon which the lower end of the standard is adapted to rest to limit its downward movement, and a coat-support carried by said standard.

2. In a floor-rack, the combination of the legs, a segment of a socket carried by each leg, an inwardly-extending flange at the lower end of each segment, bolts for securing said socket-segments together, an upright standard securely held in said socket and resting upon said flanges, whereby the same is prevented from slipping downwardly, and a revoluble coat-support carried by said standard.

3. In a combined garment and umbrella rack, the combination of the legs, a segment of a socket carried by each leg, bolts for se-

curing said socket-segments together, a hook attached to each leg, a pan resting on said hooks, an umbrella-support carried by said standard, and a revoluble coat-support carried  
5 by said standard.

4. In a coat and umbrella rack, the combination of legs, a segment of a socket carried by each leg and provided with a bolt-opening, lugs on said segment for receiving a bolt,  
10 bolts for securing said socket-segments together, a hook attached to each leg, a pan resting on said hooks, an umbrella-support carried by said standard, and supporting arms or brackets on the standard.

5. In a coat and umbrella rack, the combination of legs, a standard firmly secured in the legs, a cap resting on said standard, a ring revoluble on the standard below said cap and supporting-brackets secured at their upper  
15 ends to said cap and extending downward to and held in position by the ring.

6. In a coat and umbrella rack, the combination of the legs, a standard firmly secured to the legs, a cap resting on said standard, a  
25 ring carrying loops revoluble on said standard below the cap, brackets hooked into said loops, and a cover-piece for securing the brackets to the cap.

7. In a coat and umbrella rack, the combination of the legs, a standard firmly secured to the legs, a cap resting on the standard and provided with lugs, a ring revoluble around said standard below the cap and carrying a  
30 plurality of loops, brackets hooked into said loops and having upwardly-extending arms, and a cover-piece embracing said arms and holding said brackets between the lugs on the  
35 cap.

8. In a coat and umbrella rack the combination of legs, a standard firmly secured to and supported by the legs, a cap resting on the standard and having lugs, a ring carrying loops revoluble on the standard below the  
40 cap, supporting-brackets hooked into said loops and provided with upwardly-extending arms, pins through said brackets below the arms and resting on the lugs of the cap, a cover-piece embracing said arms and holding  
45 said supports between the lugs of the cap, and a securing-bolt passing through the cap and cover-piece for the purpose described.

9. In a rack, the combination of legs, a standard secured between the legs, downwardly-extended brackets on the standard, a revoluble ring supporting the brackets at their lower  
55 ends and means for supporting the brackets at their upper ends to the standard, including a cap common to each of the brackets.

10. In a clothes-support, the combination of legs, a segment of a socket carried by each leg having an inwardly-turned flange at its  
60 lower end, means for securing said segments together, and an upright standard held by said socket and resting upon said flanges, where- by its downward movement is prevented.

11. In a rack, the combination of legs, a segment of a socket carried by each leg having a supporting member at its lower end, means for securing said segments together, an upright  
70 standard held by said socket and resting upon said supporting members, brackets mounted upon the standard, a cap on the standard fitting over the upper end of the brackets and a revoluble ring below the cap engaging the brackets at their lower ends. 75

12. In a rack, the combination of legs, a segment of a socket carried by each leg having a supporting member at its lower end, means for adjustably securing said segments together, an upright standard held by said socket  
80 and resting upon said supports whereby the downward movement is prevented and brackets detachably mounted upon said standard.

13. In a floor-rack, the combination of a standard, a bracket, a support for the bracket,  
85 a cover member resting upon the top of the standard and having downwardly-extending flanges engaging over the bracket to hold the same in position upon the support, and a revoluble ring below said cover member to which  
90 the lower end of the bracket is secured.

14. In a floor-rack, the combination of a standard, a bracket, a revoluble support to which the bracket is detachably connected at  
95 its upper end, a cover mounted upon the standard and engaging over the top of the bracket, means for clamping a portion of the bracket between the support and cover, and a revoluble ring to which the lower end of the  
100 bracket is secured.

15. In a floor-rack, the combination of legs, a segment of a socket carried by each of the legs, means for securing said segments together, an upright standard held within said  
105 socket, a bracket, a revoluble support for the bracket, a cover member on the top of the standard having downwardly-extending flanges engaging the bracket to hold the same in position upon the support, and a revoluble ring on the standard below the cover having means  
110 engaging the lower end of the bracket.

16. In combination, a standard, a head thereon having shoulders with vertical grooves therebetween, hooks having shanks resting in the grooves and on the shoulders, and a cap  
115 attached to the head and binding the shanks on the shoulders.

17. In combination, a standard, having outwardly-extended lugs arranged in pairs at the top thereof, hooks having shanks arranged  
120 between the lugs of each pair and resting upon the top thereof, and a cap on the standard engaging the upper surface of the shank to bind the same to the lugs.

18. In combination, a standard, a head adjustably secured thereupon having shoulders with vertical grooves therebetween, hooks having shanks resting in the grooves and on the shoulders, and a cap attached to the head  
125 and binding the shanks on the shoulders. 130

19. In combination, a standard, having out-  
wardly-extended lugs arranged in pairs at the  
top thereof, hooks having shanks arranged  
between the lugs of each pair and resting upon  
5 the top thereof, a cap on the standard, and  
means associated therewith for binding the  
same against the upper surface of the shanks.

In testimony whereof I affix my signature in  
presence of two witnesses:

JOHN H. PETROSKEY.

Witnesses:

JAS. P. BARRY,

H. C. SMITH.