

FORM 1

COMMONWEALTH OF AUSTRALIA

PATENTS ACT 1952

644649

APPLICATION FOR A STANDARD PATENT

I\We,

SONY CORPORATION

of

7-35 KITASHINAGAWA 6-CHOME  
SHINAGAWA-KU  
TOKYO  
JAPAN

hereby apply for the grant of a standard patent for an invention entitled:

METHOD AND APPARATUS FOR TRANSMITTING A SIGNAL WITH AN OFFSET WHICH FOLLOWS A RECEIVED SIGNAL.

which is described in the accompanying complete specification

Details of basic application(s):

Number of basic application	Name of Convention country in which basic application was filed	Date of basic application
P127585/90	JP	17 MAY 90

My/our address for service is care of GRIFFITH HACK & CO., Patent Attorneys, 601 St. Kilda Road, Melbourne 3004, Victoria, Australia.

DATED this 13th day of May 1991

SONY CORPORATION

GRIFFITH HACK & CO

TO: The Commissioner of Patents.

M 026949 130591

PATENTS ACT 1952

APPLICATION BY ASSIGNEE OF INVENTOR

DECLARATION IN SUPPORT OF AN APPLICATION FOR A PATENT

NAME OF APPLICANT

In support of an application made by: SONY CORPORATION

TITLE

for a patent for an invention entitled: METHOD AND APPARATUS FOR TRANSMITTING A SIGNAL WITH AN OFFSET WHICH FOLLOWS A RECEIVED SIGNAL.

FULL NAME AND ADDRESS OF SIGNATORY

I, Noel T. BRETT, Registered Patent Attorney of GRIFFITH HACK & CO., 601 St. Kilda Road Melbourne, Victoria 3004, AUSTRALIA

do solemnly and sincerely declare as follows:

1. I am authorised by the above mentioned applicant for the patent to make this declaration on its behalf.

2. The name and address of each actual inventor of the invention is as follows:

Mitsuhiro Suzuki, c/o Sony Corporation, 7-35, Kitashinagawa 6-chome, Shinagawa-ku, Tokyo, Japan;  
Takushi Kunihiro, c/o Sony Corporation, 7-35, Kitashinagawa 6-chome, Shinagawa-ku, Tokyo, Japan

3. The facts upon which the applicant is entitled to make this application are as follows:

The said applicant is the assignee of the said inventors

4. The basic application(s) as defined by Section 141 of the Act was (were) made as follows:

Country Japan on 17th May 1990  
in the name(s) Sony Corporation  
and in \_\_\_\_\_ on \_\_\_\_\_  
in the name(s) \_\_\_\_\_

5. The basic application(s) referred to in the preceding paragraph was (were) the first application(s) made in a Convention country in respect of the invention the subject of this application.

FULL NAME AND ADDRESS OF INVENTOR(S)

SEE NOTES OVER

DELETE PARAGRAPHS 4 AND 5 FOR NON-CONVENTION APPLICATION

PLACE AND DATE OF SIGNING

Declared at Melbourne, AUSTRALIA  
this Thirteenth day of May 19 91  
Signed [Signature]  
Position PARTNER

**GRIFFITH HACK & CO**

PATENT AND TRADE MARK ATTORNEYS

MELBOURNE . SYDNEY . PERTH



AU9176473

(12) PATENT ABRIDGMENT (11) Document No. AU-B-76473/91  
(19) AUSTRALIAN PATENT OFFICE (10) Acceptance No. 644649

(54) Title  
METHOD AND APPARATUS FOR TRANSMITTING A SIGNAL WITH AN OFFSET WHICH FOLLOWS  
A RECEIVED SIGNAL

International Patent Classification(s)  
(51)<sup>5</sup> H04B 007/26 H04Q 007/94 H04B 007/005

(21) Application No. : 76473/91 (22) Application Date : 13.05.91

(30) Priority Data

(31) Number (32) Date (33) Country  
2-127585 17.05.90 JP JAPAN

(43) Publication Date : 21.11.91

(44) Publication Date of Accepted Application : 16.12.93

(71) Applicant(s)  
SONY CORPORATION

(72) Inventor(s)  
MITSUHIRO SUZUKI; TAKUSHI KUNIHIRO

(74) Attorney or Agent  
GRIFFITH HACK & CO , GPO Box 1285K, MELBOURNE VIC 3001

(56) Prior Art Documents  
AU 600638 27568/88 H04L 27/22  
AU 571302 37491/85 H04L 27/22  
EP 400782

(57) Claim

1. A transmitting and receiving apparatus for receiving a signal of an actual reception carrier frequency and transmitting a signal of an actual transmission carrier frequency, comprising:

receiving means for receiving a broadcast signal;

reference frequency means for providing a reference reception carrier frequency and a reference transmission carrier frequency which are different from each other;

reception offset frequency detecting means for detecting an offset frequency which is the difference between the actual reception carrier frequency of the received signal and the reference reception carrier frequency;

transmission signal generating means for generating a first transmission signal having the reference transmission carrier frequency;

multiplying means for multiplying the first transmission signal by the detected offset

(11) AU-B-76473/91

-2-

(10) 644649

frequency to generate a second transmission signal with the actual transmission carrier frequency; and

transmitting means for transmitting the second transmission signal.

AUSTRALIA

PATENTS ACT 1952

Form 10

COMPLETE SPECIFICATION

(ORIGINAL)

FOR OFFICE USE

644649

Short Title:

Int. Cl:

Application Number:  
Lodged:

Complete Specification-Lodged:  
Accepted:  
Lapsed:  
Published:

Priority:

Related Art:

---

TO BE COMPLETED BY APPLICANT

Name of Applicant:

SONY CORPORATION

Address of Applicant: 7-35 KITASHINAGAWA 6-CHOME  
SHINAGAWA-KU  
TOKYO  
JAPAN

Actual Inventor:

Address for Service: GRIFFITH HACK & CO.,  
601 St. Kilda Road,  
Melbourne, Victoria 3004,  
Australia.

Complete Specification for the invention entitled:  
METHOD AND APPARATUS FOR TRANSMITTING A SIGNAL WITH  
AN OFFSET WHICH FOLLOWS A RECEIVED SIGNAL.

The following statement is a full description of this invention  
including the best method of performing it known to me:-

METHOD AND APPARATUS FOR TRANSMITTING A SIGNAL WITH AN OFFSET WHICH FOLLOWS A RECEIVED SIGNAL

BACKGROUND OF THE INVENTION

Field of the Invention

5 The present invention generally relates to communication systems and, more particularly, is directed to a communication system having a reference reception carrier frequency which differs from and follows a reference transmission carrier frequency.

Description of the Prior Art

10

15

A TDMA (time division multiple access) system is known as one type of digital cellular communication system in which a base station and a mobile station are connected via radio waves. According to this TDMA system, six receiving slots, for example, are provided for every channel of the 900 MHz band and in each mobile station an incoming signal in one of the six slots is received for a period of 20 milliseconds at intervals of 120 milliseconds. Six transmission slots are similarly provided for every channel, and in each mobile station an outgoing signal in one of the six transmission slots is similarly transmitted. A reference receiving carrier frequency and a reference transmitting carrier frequency in a single mobile station are different from each other. By way of example, a frequency 45 MHz lower than the reference receiving carrier frequency is employed as the reference transmitting carrier frequency.

20

25

30

When the mobile station is moved, an offset frequency occurs in the actual received carrier frequency due to the Doppler effect. Also, if the oscillation frequency of a reference oscillator in the base station, which uses a quartz crystal, is not correct, then an offset frequency will also occur.

In the mobile station, the offset frequency of the transmission carrier frequency must be maintained within a band  $\pm 200$  Hz from the reference transmitting carrier frequency.

5 For this reason, it has been proposed that the mobile station be provided with a PLL (phase locked loop) which is locked to the reception carrier frequency of the received signal to thereby produce the transmission carrier signal. However, since the received signal is a burst signal which is received for 20 milliseconds at intervals of 120 milliseconds, it is very difficult to lock the PLL to the reception carrier frequency of the received signal, as the lock frequency must be determined during a short period of time (20 milliseconds) and maintained for a period of 100 milliseconds between received signals, and the transmission offset frequency must be maintained within the band  $\pm 200$  Hz from the reference transmitting carrier frequency.

10  
15  
20  
OBJECTS AND SUMMARY OF THE INVENTION

Accordingly, it is an object of the present invention to provide an improved communication system in which the aforementioned shortcomings and disadvantages encountered with the prior art can be substantially eliminated.

25  
30 More specifically, it is an object of the present invention to provide a communication system in which an outgoing signal has a transmission offset frequency which follows a reception offset frequency, so that the actual transmission carrier frequency of the outgoing signal follows the actual reception carrier frequency of the received signal and can be transmitted with satisfactory responsiveness and ease.

According to one aspect of the present invention there is provided a transmitting and receiving apparatus for receiving a signal of an actual reception carrier frequency and transmitting a signal of an actual transmission carrier frequency, comprising:

5 receiving means for receiving a broadcast signal;  
reference frequency means for providing a reference reception carrier frequency and a reference transmission carrier frequency which are different from  
10 each other;

reception offset frequency detecting means for detecting an offset frequency which is the difference between the actual reception carrier frequency of the received signal and the reference reception carrier  
15 frequency;

transmission signal generating means for generating a first transmission signal having the reference transmission carrier frequency;

20 multiplying means for multiplying the first transmission signal by the detected offset frequency to generate a second transmission signal with the actual transmission carrier frequency; and

transmitting means for transmitting the second transmission signal.

25 According to another aspect of the present invention there is provided a method for transmitting a signal of an actual transmission carrier frequency which follows the actual reception carrier frequency of a received signal, comprising:

30 receiving a broadcast signal;



providing a reference reception carrier frequency and a reference transmission carrier frequency which are different from each other;

5 detecting an offset frequency which is the difference between the actual reception carrier frequency of the received signal and the reference reception carrier frequency;

generating a first transmission signal having the reference transmission carrier frequency;

10 multiplying the first transmission signal by the detected offset frequency to generate a second transmission signal with the actual transmission carrier frequency; and transmitting the second transmission signal.

15 A preferred embodiment of the invention will now be described in detail, by way of example only, with reference to the accompanying drawings.

BRIEF DESCRIPTION OF THE DRAWINGS

20 Fig. 1 is a block diagram showing an embodiment of a transmitting and receiving system according to the present invention; \_\_\_\_\_



Fig. 2 is a block diagram showing a modulating circuit used in the present invention; and

Figs. 3I to 3III are diagrams showing the encoding operation of the modulating circuit of Fig. 2.

5

DETAILED DESCRIPTION OF THE PREFERRED EMBODIMENT

Figures 1 through 3III of the drawings depict various preferred embodiments of the present invention for purposes of illustration only. One skilled in the art will readily recognize from the following discussion that alternative embodiments of the structures and methods illustrated herein may be employed without departing from the principles of the invention described herein.

Fig. 1 shows an embodiment of a transmitting and receiving system according to the present invention. In this embodiment, the present invention is applied to a TDMA digital communication system in which the base station and the mobile station are connected via radio waves. Six receiving slots, for example, are provided for every channel of the 900 MHz band, and a mobile station receives an incoming signal in one slot thereof at intervals of 120 milliseconds for a period of 20 milliseconds. Six transmission slots are similarly provided for every channel, and a mobile station transmits an outgoing signal in one slot thereof with a similar time and interval. The reference receiving carrier frequency and the reference transmitting carrier frequency in a single mobile station are different from each other.

Fig. 1 shows how the signal processing occurs in the present invention with a digital signal processor in a mobile station (i.e., a mobile telephone) in the form of a block diagram. As shown in Fig. 1, a

30

10  
15

20

25

signal RX received by a receiving circuit 11 is supplied through a multiplier 12 to a phase error detector 10. This phase error detector 10 produces only the imaginary part of the signal supplied thereto. The output of the phase error detector 10 is supplied to a loop filter (LF) 14 of a phase locked loop (PLL) 13.

The PLL 13 is composed of a PLL 13R and a PLL 13T. The PLL 13R is comprised of the loop filter 14, a VCO (voltage controlled oscillator) 15 and a phase converter  $[\exp(j\theta)]$  16. The PLL 13T is similarly comprised of the loop filter 14, a VCO 21 and a phase converter  $[\exp(j\theta)]$  22. The above-described phase converters 16 and 22 generate complex sine waves corresponding to the signals supplied thereto.

The loop filter 14 is composed of a multiplier 24 for multiplying the received signal with a coefficient K, a multiplier 25 for multiplying an output of the multiplier 24 by a coefficient a (where  $a = K/2$ ), a sampling circuit 27 for sampling the output of the multiplier 25 at a sampling interval  $T_s$ , an adder 28 which adds the output of the sampling circuit 27 and the output of a delay circuit 29, an adder 30 for adding the outputs of the multiplier 24 and the adder 28, and delay circuit 29, which delays the output of the adder 28 by one sampling interval  $T_s$  and supplies the resulting delayed signal back to adder 28. The sampling circuit 27, the adder 28 and the delay circuit 29 constitute an integrator.

The VCO 15 is composed of a sampling circuit 31 for sampling the output of the loop filter 14, that is, the output of adder 30, again at a sampling interval  $T_s$ , an adder 32 for adding the output of the sampling circuit 31 and the output of a delay circuit 33, and delay circuit 31, which again delays the

output of adder 32 by one sampling interval  $T_s$  and supplies the resulting delayed signal back to adder 32. Thus, the VCO 15 also constitutes an integrator.

5 The output of the VCO 15, that is, the output of adder 32, is then supplied to the phase converter 16, in which the phase thereof is determined. The output of phase converter 16 is supplied to multiplier 12.

10 The VCO 21 is supplied with a signal from the loop filter 14, that is, the output of the adder 28, through a buffer 20, and is composed of a sampling circuit 34, again having a sampling interval  $T_s$ , an adder 35 for adding the output of the sampling circuit 34 and the output of a delay circuit 36, and delay circuit 36 which again delays the output of adder 35 by one sampling interval  $T_s$  and supplies the resulting delayed signal back to adder 35, thus again constituting an integrator.

15 The VCO 21 may alternatively be supplied with the output of the loop filter 14, that is, the output of adder 30, through the buffer 20.

20 The output of the VCO 21, that is, the output of the adder 35, is then supplied to the phase converter 22, in which the phase thereof is determined, and the output of phase converter 22 is fed to a multiplier 19.

25 Assuming that  $F_R$  represents the actual received carrier frequency of the received signal RX detected by the receiving circuit 11 (that is, the signal received by the mobile station from the signal transmitted from the base station), then the actual received carrier frequency  $F_R$  is expressed as

$$F_R = RF_0 \pm \Delta F$$

30 where  $RF_0$  is the reference reception carrier frequency and  $\Delta F$  is the offset frequency.

The signal RX obtained from the receiving circuit 11 is supplied through the multiplier 12 and the phase error detector 10 to the loop filter 14, in which an angular frequency  $\omega$  of the offset frequency  $\Delta F$  is detected, and this detected angular frequency  $\omega$  is supplied to the VCO 15, in which the angle  $\theta$  is detected. The angle  $\theta$  is then supplied to the phase converter 16 which then generates a frequency signal  $x_R$  of the offset frequency  $\Delta F$ , and this frequency signal  $x_R$  is supplied to the multiplier 12, where it is multiplied with the received signal RX, so that a received signal  $RX_0$ , having the reference received carrier frequency  $FR_0$ , is obtained at the output terminal 17. This received signal  $RX_0$  is supplied to, and demodulated by, a demodulator (not shown) to provide an audio signal.

Another angular frequency  $\omega'$  (the output of the adder 28) of an offset frequency  $\Delta F'$  detected by the integrator formed of the elements 27, 28 and 29 within the loop filter 14 is supplied to the VCO 21, and an angle  $\theta'$  is detected. This detected angle  $\theta'$  is supplied to the phase converter 22 which generates a frequency signal  $x_T$  of the offset frequency  $\Delta F'$ . This frequency signal  $x_T$  is supplied to multiplier 19, where it is multiplied with a transmission signal  $TX_0$ , supplied from a terminal 18 and having a reference transmission carrier frequency  $FT_0$ , to provide a transmission signal TX having an actual transmission carrier frequency FT. This transmission signal TX is transmitted to the base station from a transmitter 23.

Assuming that FT represents the actual transmission carrier frequency of the transmission signal TX, then FT is expressed as

$$FT = FT_0 \mp \Delta F'$$

where  $FT_0$  is the reference transmission carrier frequency.

The angular frequency  $\omega$  supplied to the VCO 15 must follow the received signal and must thus be the output of the adder 30. However, the angular frequency  $\omega'$  supplied to the VCO 21 need not follow the received signal so that the signal-to-noise (S/N) ratio can be improved by utilizing the output of the adder 28, which has the low noise of the received signal, before additional noise is added by the adder 30. The difference between the angular frequencies  $\omega$  and  $\omega'$  is negligible in comparison to the difference between the transmission and reception frequencies.

According to the above communication system, when the reference reception carrier frequency  $FR_0$  and the reference transmission carrier frequency  $FT_0$  are different, the offset frequency  $\Delta F'$  of the actual reception carrier frequency  $FR$  of the received signal RX relative to the reference reception carrier frequency  $FR_0$  is detected by the PLL 13R and the frequency signal  $x_T$  of the thus detected offset frequency  $\Delta F'$  is multiplied with the transmission signal  $TX_0$ , which has the reference transmission carrier frequency  $FT_0$ , by the multiplier 19 to produce the transmission signal TX which is transmitted with an actual transmission carrier frequency  $FT$ . Thus, the transmission signal TX has an actual transmission carrier frequency  $FT$  with the same transmission offset frequency  $\Delta F'$  as the reception offset frequency  $\Delta F'$ , and can be transmitted with excellent responsiveness and ease.

Similarly, the offset frequency  $\Delta F$  of the actual reception carrier frequency  $FR$  of the received signal RX relative to the reference reception carrier frequency  $FR_0$  is detected by the PLL 13R and the

frequency signal  $x_R$  of the thus detected offset frequency  $\Delta F$  is provided and then multiplied with the transmission signal  $RX$  of the actual reception carrier frequency  $FR$  by the multiplier 12 to produce the reception signal  $RX_0$  of the reference reception carrier frequency  $FR_0$ . Thus, even when the actual reception carrier frequency  $FR$  of reception signal  $RX$  contains the offset frequency  $\Delta F$ , the audio signal can be demodulated with the same demodulation characteristic as that of a reception signal  $RX_0$  of the reference reception carrier frequency  $FR_0$  by the demodulating circuit.

This embodiment uses a  $\pi/4$  shifted QPSK (quadrature phase shift keying) modulation circuit which is shown in Fig. 2. However, the present invention is not limited to the above modulating circuit and can be applied to either an analog communication system or a digital communication system.

As shown in Fig. 2, a serial digital audio signal  $bm$  from an input terminal 1 is supplied to a serial-to-parallel converter 2, where it is converted to parallel digital signals  $X_K$  and  $Y_K$  of 2 bits and then supplied to a differential phase encoder 3.

The encoding of the differential phase encoder 3 will be described with reference to Figs. 3I to 3III.

As shown in Fig. 3I, points A (1, 1), B (-1, 1), C (-1, -1) and D (1, -1) on the perpendicular I axis (real axis) and Q axis (imaginary axis) are determined. Then, as shown in Fig. 3II, points a (1, 1), b (-1, 1), c (-1, -1) and d (1, -1) on the perpendicular I' axis (real axis) and Q' axis (imaginary axis), which result from rotating the orthogonal I axis and Q axis coordinates by 45 degrees ( $\pi/4$ ), are also determined.

When the I' axis and Q' axis coordinates are moved in parallel and superimposed on the I axis and Q axis coordinates so that their origins coincide with each other, the coordinates of the points a, b, c, and d on the I' axis and Q' axis coordinates on the I axis and Q axis are presented as a (0,  $\sqrt{2}$ ), b ( $-\sqrt{2}$ , 0), c (0,  $-\sqrt{2}$ ) and d ( $\sqrt{2}$ , 0).

The encoded outputs  $I_K$  and  $Q_K$  of the encoder 3 are then moved from any one of the points A through D on the I axis and Q axis coordinates to any one of the points a through d in accordance with the outputs  $X_K$  and  $Y_K$  of 2 bits from the serial-to-parallel converter circuit 2 and moved from any one of the points a to d to any one of the points A to D in response to the outputs  $X_K$  and  $Y_K$  of 2 bits of the serial-to-parallel converter circuit 2. The movements between any one of the points A to D and any one of the points a to d are represented in Fig. 3III. Such movements never pass through the origin O.

The movements between any one of the points A to D on the I axis and Q axis coordinates and any one of the points a to d on the I' axis and Q' axis coordinates can be expressed by the change  $\Delta\phi$  of the angles of straight lines connecting the respective points and the origin O.

Accordingly, a relation between the outputs  $X_K$ ,  $Y_K$  and the difference  $\Delta\phi$  will be represented on the following truth table.

5  
10  
15  
20  
25

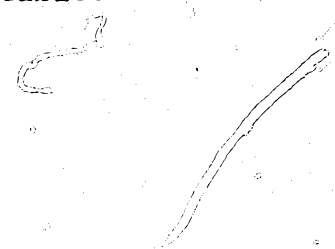

$X_K$	$Y_K$	$\Delta\phi$
1	1	$-3\pi/4$
0	1	$3\pi/4$
0	0	$\pi/4$
1	0	$-\pi/4$

5

The encoded outputs  $I_K$  and  $Q_K$  are respectively supplied through baseband filters 4a and 4b to modulators (multipliers) 5a and 5b, where a carrier from a carrier generator 6 and a carrier whose phase is shifted by 90 degrees from the former carrier by a 90 degree phase shifter 7 are modulated (multiplied) with the respective encoded outputs. The outputs are then added by an adder 8 and output from an output terminal 9 as a digital modulated signal.

15

Thus, the present invention as described above is a communication system in which the reference reception carrier frequency and the reference transmission carrier frequency are different. An offset frequency, which is the difference in the actual reception carrier frequency of the received signal relative to the reference reception carrier frequency, is detected. The frequency signal of the thus detected offset frequency is multiplied with the transmission signal of the reference transmission carrier frequency to obtain a transmission signal of an actual transmission carrier frequency which has an offset frequency relative to the reference transmission carrier frequency which follows the offset frequency of the received signal. The transmission signal of can then be transmitted with satisfactory responsiveness and with ease.

30

From the above description, it will be apparent that the invention disclosed herein provides a novel

and advantageous apparatus for a mobile communication system.

The foregoing discussion discloses and describes merely exemplary methods and embodiments of the present invention. As will be understood by those familiar with the art, the invention may be embodied in other specific forms without departing from the spirit or essential characteristics thereof. For example, different specific circuits could be used, in either the analog or digital domain. Accordingly, the disclosure of the present invention is intended to be illustrative, but not limiting, of the scope of the invention, which is set forth in the following claims.

5

10

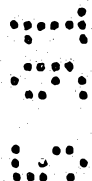

THE CLAIMS DEFINING THE INVENTION ARE AS FOLLOWS:

1. A transmitting and receiving apparatus for receiving a signal of an actual reception carrier frequency and transmitting a signal of an actual transmission carrier frequency, comprising:

receiving means for receiving a broadcast signal;

reference frequency means for providing a reference reception carrier frequency and a reference transmission carrier frequency which are different from each other;

reception offset frequency detecting means for detecting an offset frequency which is the difference between the actual reception carrier frequency of the received signal and the reference reception carrier frequency;

transmission signal generating means for generating a first transmission signal having the reference transmission carrier frequency;

multiplying means for multiplying the first transmission signal by the detected offset frequency to generate a second transmission signal with the actual transmission carrier frequency; and

transmitting means for transmitting the second transmission signal.

2. A transmitting and receiving apparatus according to claim 1, wherein the reference frequency means further comprises means for setting the reference reception carrier frequency and the reference transmission carrier frequency in a predetermined relationship.

5 3. A transmitting and receiving apparatus according to claim 2, wherein the receiving means further comprises means for receiving a broadcast signal on a time-division basis, and the transmitting means further comprises means for transmitting the second signal on a time-division basis.

10 4. A transmitting and receiving apparatus according to claim 3 wherein the reception offset frequency detecting means further comprises a loop filter.



5. A transmitting and receiving apparatus according to claim 4 wherein the loop filter further comprises an integrator such that the output signal of the integrator is the reception offset frequency.

15 6. A transmitting and receiving apparatus according to claim 2 further comprising means for modulating the transmission and received signals by a  $\pi/4$  shifted QPSK (quadrature phase shift keying).

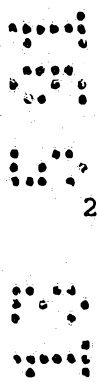

20 7. A method for transmitting a signal of an actual transmission carrier frequency which follows the actual reception carrier frequency of a received signal, comprising:

- receiving a broadcast signal;
  - providing a reference reception carrier frequency and a reference transmission carrier frequency which are different from each other;
  - detecting an offset frequency which is the difference between the actual reception carrier frequency of the received signal and the reference reception carrier frequency;
- 25
- 30

generating a first transmission signal having the reference transmission carrier frequency;

5

multiplied by the detected offset frequency to generate a second transmission signal with the actual transmission carrier frequency; and

transmitting the second transmission signal.

10  
15

8. A method for transmitting a signal according to claim 7, wherein the step of providing a reference reception carrier frequency and a reference transmission carrier frequency further comprises setting the reference reception carrier frequency and the reference transmission carrier frequency in a predetermined relationship.

20

9. A method for transmitting a signal according to claim 8 wherein the step of receiving a broadcast signal further comprises receiving a broadcast signal on a time-division basis, and the step of transmitting the second transmission signal further comprises transmitting the second signal on a time-division basis.

25

10. A method for transmitting a signal according to claim 9, wherein the step of detecting an offset frequency further comprises providing a loop filter.

30

11. A method for transmitting a signal according to claim 10, wherein the step of providing a loop filter further comprises providing an

integrator such that the output signal of the integrator is the reception offset frequency.

12. A method for transmitting a signal according to claim 8 further comprising modulating the transmission and received signals by a  $\pi/4$  shifted QPSK (quadrature phase shift keying).

13. A transmitting and receiving apparatus substantially as herein described with reference to and as illustrated in the accompanying drawings.

14. A method for transmitting a signal substantially as herein described with reference to and as illustrated in the accompanying drawings.

Dated this 16th day of September 1993.

SONY CORPORATION  
By Its Patent Attorneys

GRIFFITH HACK & CO.  
Fellows Institute of Patent Attorneys of Australia.

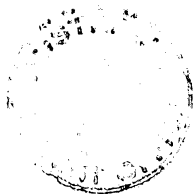

ABSTRACT OF THE DISCLOSURE

A transmitting and receiving apparatus suitable for use as a digital cellular type mobile station. The reference reception carrier frequency and the reference transmission carrier frequency are different. Signals are transmitted and received such that an offset frequency of a received signal of an actual reception carrier frequency relative to the reference reception carrier frequency is detected and multiplied with a signal of the reference transmission carrier frequency, and the multiplied output used as the transmitted signal of an actual transmission carrier frequency which follows the actual reception carrier frequency.

5

10



76473

FIG. 1

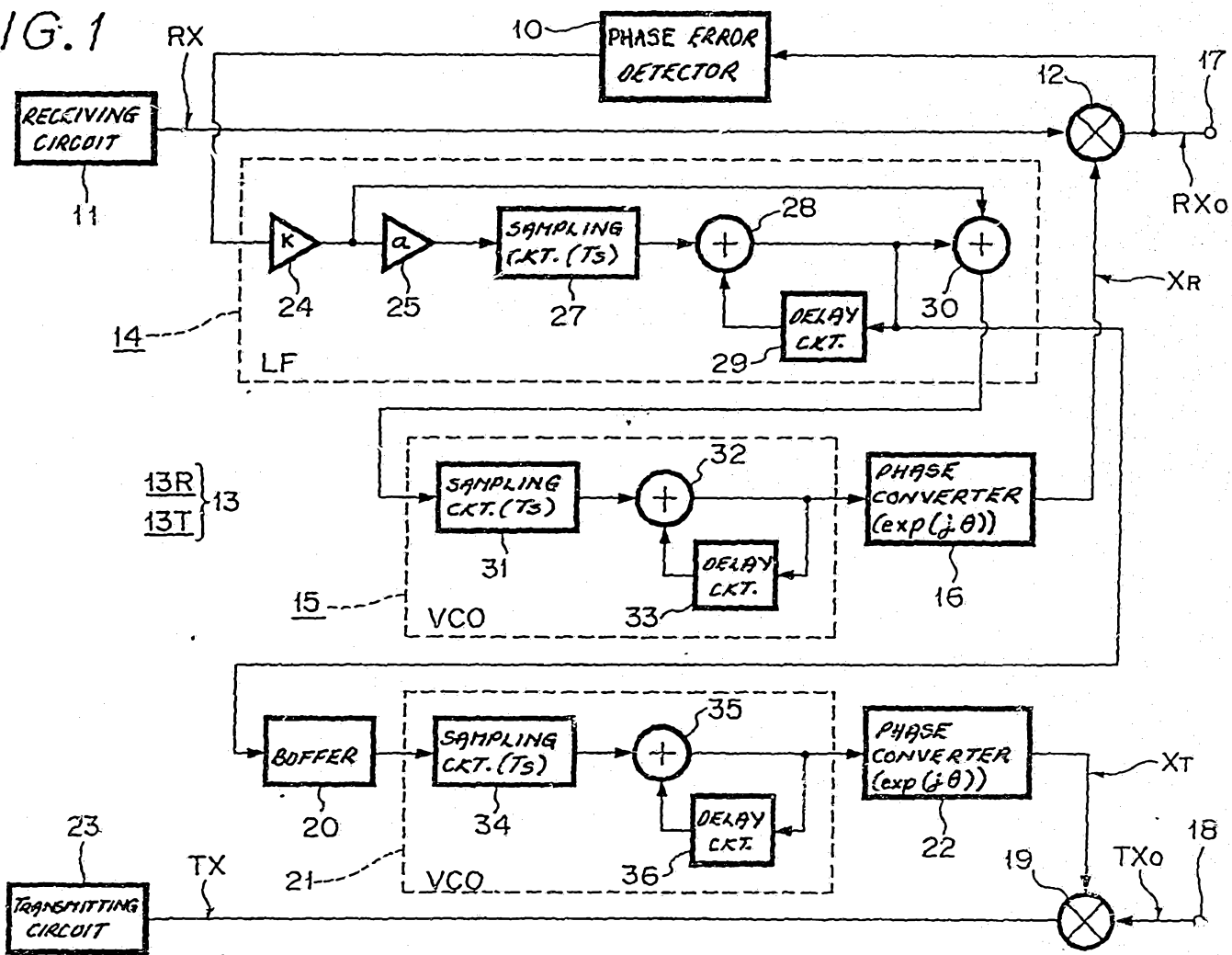

76473/91

2 801 78473

FIG. 2

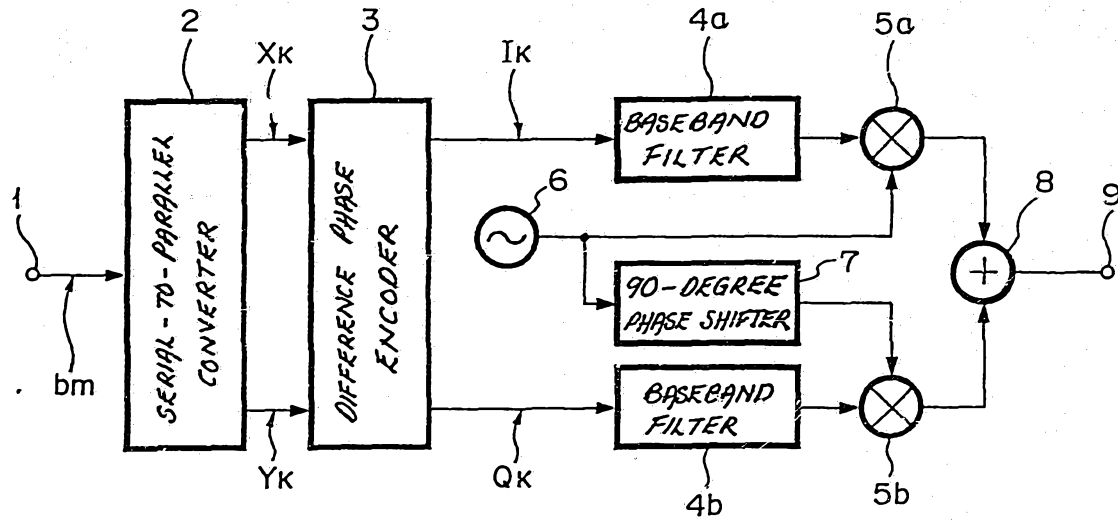

FIG. 3I

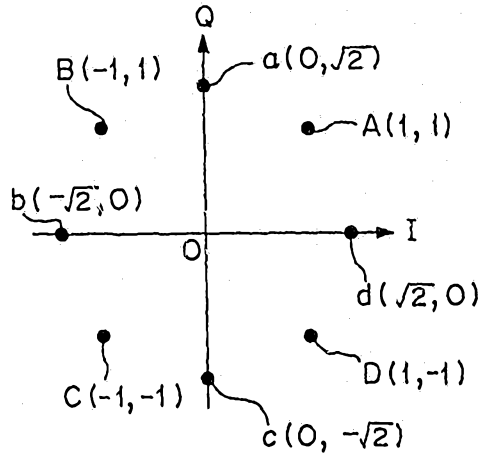

FIG. 3II

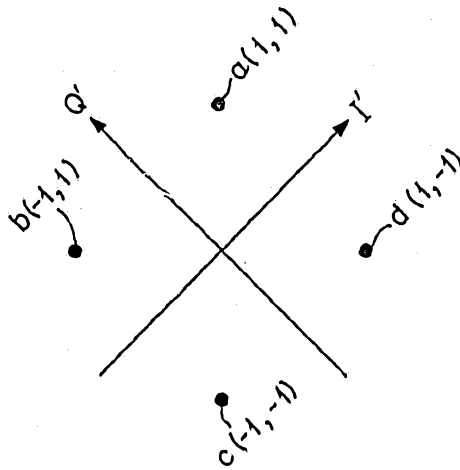
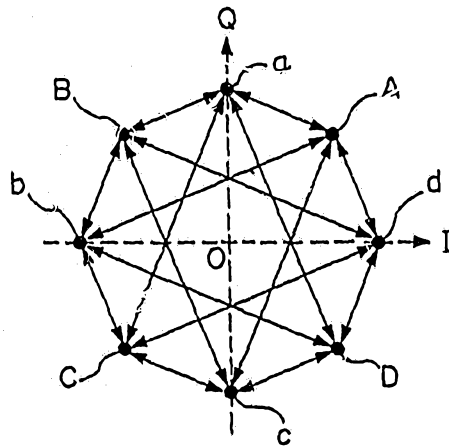

FIG. 3III



R  
 E  
 S  
 E  
 A