

No. 889,091.

PATENTED MAY 26, 1908.

H. BALLINGER.
MOLD FOR POSTS.
APPLICATION FILED APR. 13, 1907.

2 SHEETS—SHEET 1.

Fig. 1.

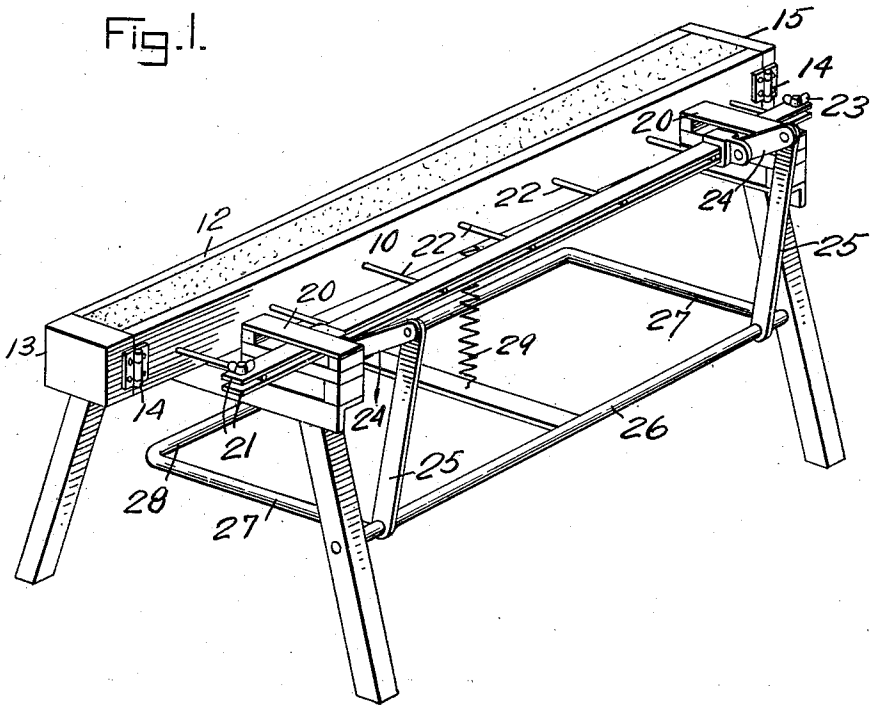
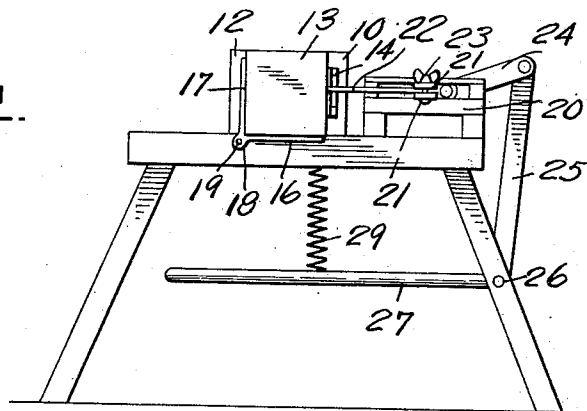

Fig. 2.



Witnesses
G. R. Thomas.
N. K. McGee.

Inventor
H. Ballinger

By *[Signature]*
Attorneys

No. 889,091.

PATENTED MAY 26, 1908.

H. BALLINGER.
MOLD FOR POSTS.

APPLICATION FILED APR. 13, 1907.

2 SHEETS—SHEET 2.

Fig. 3.

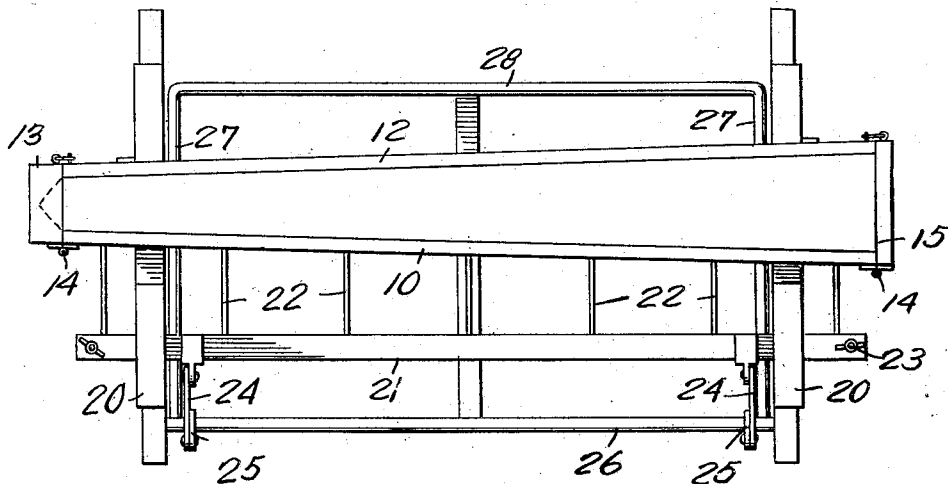
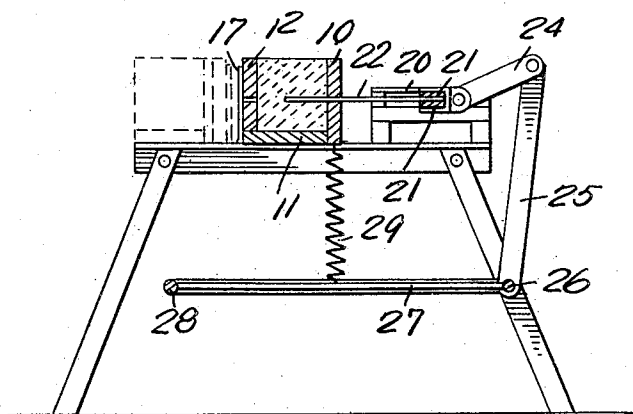

Fig. 4.



Witnesses

G. R. Thomas.
W. K. McGeer.

Inventor

H. Ballinger

By

Charles Chanale

Attorneys

UNITED STATES PATENT OFFICE.

HARVEY BALLINGER, OF MARION, INDIANA.

MOLD FOR POSTS.

No. 889,091.

Specification of Letters Patent.

Patented May 26, 1908.

Application filed April 13, 1907. Serial No. 367,965.

To all whom it may concern:

Be it known that I, HARVEY BALLINGER, a citizen of the United States, residing at Marion, in the county of Grant, State of Indiana, have invented certain new and useful Improvements in Molds for Posts; and I do hereby declare the following to be a full, clear, and exact description of the invention, such as will enable others skilled in the art to which it appertains to make and use the same.

This invention relates to molds for making fence-posts and similar articles from primarily plastic substances, such as prepared cement and artificial stone.

Molds for casting articles of the kind mentioned must be made quite strong and durable, and it is desirable that their construction should be such as to permit of the removal of the sides and ends after the casting is effected.

It is the object of my invention to provide improvements in the mold which will enhance their strength and efficiency and enable them to form holes through the posts for the reception of the hair-pin staples used for attaching the fencing to the posts and for other means in the construction of a fence.

Other objects of greater or less importance are had in view, as will clearly appear from the detailed disclosure of the invention and the drawings hereto annexed, and forming a part thereof to which reference is to be had.

Of the said drawings, Figure 1 is a perspective view of the mold filled with concrete, and in readiness to have the molded post removed. Fig. 2 is an end view. Fig. 3 is a plan. Fig. 4 is a cross section showing by dotted lines the post turned out of the mold and in position to cure.

Similar figures of reference designate similar parts or features, as the case may be, wherever they occur.

In the drawings, the mold shown may, for the purposes of this specification, be considered as being eight feet long and to be composed of wood lined with steel; cast or angle iron sheared to proper size; boiler iron properly stayed or of other material suited to the purpose. The supporting frame or trestles upon which the mold rests, as equipped, cooperate with the mold in the formation of posts, are made of angle iron and wood or of other suitable material as may be best suited to the purposes of the invention.

10 designates a stationary side of the mold,

11, the bottom, and 12 the other side of the mold, the latter being removable.

13 represents the top end piece which is thick, and on its inner side is so formed as to give a pyramidal or other desired shape to the top of the post.

14 designate the hinges which connect the top end piece 13 and bottom end 15 to the stationary side in such manner as to allow the said end pieces to be swung outward away from the casting when the latter is to be removed.

The bottom 11, when the operation of casting is going on, rests on a supporting frame with its edge against the lower inner side of the stationary side, the straps 16 on the bottom thereof serving as stays for the side 12 which stands on edge next against the bottom 11. The hinges connecting the side 12 with the bottom consist of a plate 17 of cast iron which may serve as a brace for the side 12 and has an eye 18, through which projects a bolt 19 that is secured to the frame of the machine. The ends 5 and 6 are provided at their free edges or ends with common flask clasps or fasteners which serve to connect the said free edges to the adjacent sides in the operation of molding.

The mold having substantially the construction described is supported in fixed position on top of the trestles shown, or it may be any other suitable structure, which is provided on its ends with supports and guides for the pin-bars 21, which are equipped with pins 22 constructed and arranged to extend through holes in the side of the stationary side 11, and by reciprocating them punch holes through the post. The pin bar consists of two pieces or lengths of strap iron or steel clamped together by suitable means, as thumb-screws 23, to hold the heads of the pins 22 between them. It is desirable that the pins should be adjustably connected with their reciprocating bar 21 in order that they may be arranged to form the holes through the post in proper places, and at as short or long intervals as may be necessary.

The bar 21 is connected with the foot treadle-bar or rod through the intervention of links 24 pivoted at one end to the pin-bar and at the other end to the upper ends of arms 25 that are secured at their lower ends to a rock shaft 26 having its bearings in the trestle. The transverse bars 27 are connected at their rear ends to the said rock-shaft 26 and at their forward ends to the longi-

tudinal treadle-bar or rod 28. A strong heli-
 cal spring 29 is connected at its lower end
 to the treadle and at its upper end to the
 trestles or trestle-frame and operates to lift
 5 the treadle and draw back the pin-bar and
 its pins. By depressing the treadle-bar 28
 by the foot, with a quick motion, the pins
 will be driven in the post and eventually, by
 cumulative strokes of the pins, be driven
 10 through it. By filling in the lower end of
 the mold with suitable pieces, formed to fit
 the mold nicely, the post can be made shorter,
 or of any desired length. The mold being
 open along its entire upper side, the concrete
 15 or other material of which it may be pro-
 posed to form the post, can be tamped in
 rapidly, and the manner in which the mold
 is formed contributes to a relatively rapid
 operation of molding. The movable side 12
 20 is provided with holes corresponding to the
 pins and the holes in the stationary side 10,
 in order that the pins may pass entirely
 through the post. By tamping the material
 in the mold solidly and taking out the molded
 25 post by "letting down," as it were, the mov-
 able side so that the post can be in a way
 iolled out of the mold, also aids in the rapid-
 ity of the molding operation.

In turning the post out of the mold to
 30 cure, after unlatching and swinging aside the

ends hinged on the stationary side, the bot-
 tom and hinged side opposite to the sta-
 tionary side will simply be turned over leav-
 ing the post to rest on the hinged side with
 the bottom standing vertically. The sta- 35
 tionary side will, of course, remain in the
 position in which it was when the post was
 being molded.

What is claimed as the invention, is:—

A mold of the character described having 40
 in combination, a bottom, a perforated sta-
 tionary side, a removable side, a cap mold-
 ing end piece, a bottom end piece, said bot-
 tom and cap end pieces being hinged to said
 stationary side, a frame supporting said 45
 mold, two pin bars, a plurality of horizon-
 tally extending pins projecting through said
 side perforations, guides secured near each
 end of said mold for holding said bars, a
 rock shaft provided with upwardly extend- 50
 ing arms, a treadle secured to said shaft, a
 spring to normally hold said shaft in one
 position, and links connecting said arms to
 said bars, all arranged as disclosed.

In testimony whereof, I affix my signature, 55
 in presence of two witnesses.

HARVEY BALLINGER.

Witnesses:

HIRAM BESHORE,

HARRY A. FORD.