

F. M. FURBER.  
LEATHER REPAIRING MACHINE.  
APPLICATION FILED MAR. 1, 1917.

1,285,672.

Patented Nov. 26, 1918

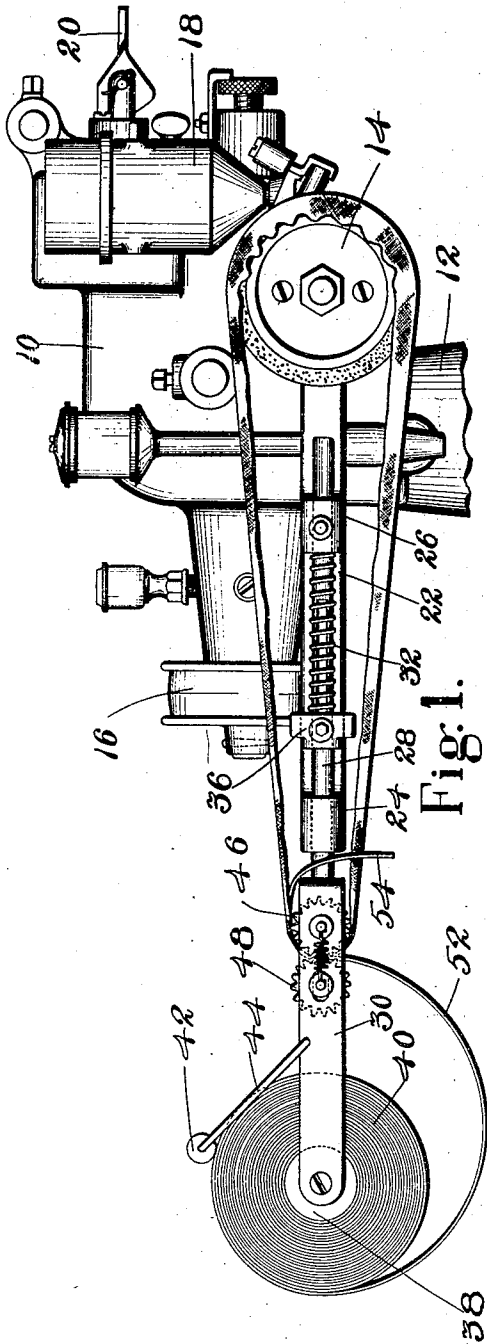

Fig. 1.

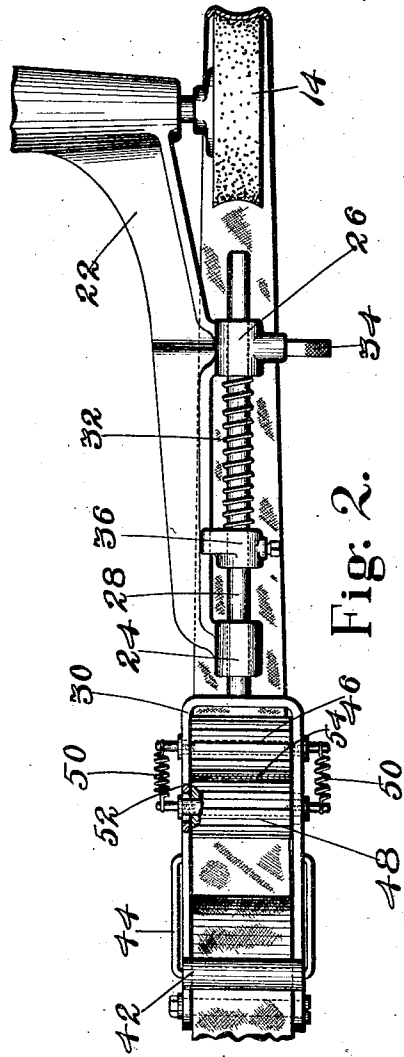

Fig. 2.

INVENTOR.  
Frederick M. Furber  
By his Attorney  
Nelson McDonald

# UNITED STATES PATENT OFFICE.

FREDERICK M. FURBER, OF REVERE, MASSACHUSETTS, ASSIGNOR, BY MESNE ASSIGNMENTS, TO UNITED SHOE MACHINERY CORPORATION, OF PATERSON, NEW JERSEY, A CORPORATION OF NEW JERSEY.

## LEATHER-REPAIRING MACHINE.

1,285,672.

Specification of Letters Patent.

Patented Nov. 26, 1918.

Application filed March 1, 1917. Serial No. 151,848.

*To all whom it may concern:*

Be it known that I, FREDERICK M. FURBER, a citizen of the United States, residing at Revere, in the county of Suffolk and State of Massachusetts, have invented certain Improvements in Leather-Repairing Machines, of which the following description, in connection with the accompanying drawings, is a specification, like reference characters on the drawings indicating like parts in the several figures.

This invention relates to leather treating machines and is shown as embodied in a machine especially designed for repairing imperfections in articles manufactured of patent or enameled leathers.

I have shown in my Patent No. 1,096,423, a machine of the type described by means of which enamel may be applied to the work and rubbed in, simulating hand work. As is well understood, the cover of a tool used for applying liquid enamel to the surface of the work soon becomes so coated with enamel as to be unfit for further use. In view of this fact, provision is made, in the machine described in the above patent, for looping a strip of sheet material around the work surface of the tool and the machine is arranged so that, as the enamel dries upon the cover of the tool and the surface becomes too hard and stiff to be fit for further use, a fresh portion of this covering material may be brought into position at the will of the operator. This strip of material has heretofore been supplied in the form of an endless belt which was looped around the tool and held taut by means of a spring-pressed roller. As soon as all parts of this belt had been used, it was necessary to replace the same, thereby occasioning some loss of time.

The object of this invention is, then, to provide mechanism for a machine of the type described in which one end of an extended strip of sheet material is looped around the work surface of the tool and held taut, which mechanism will be arranged automatically to draw a fresh portion of sheet material into the loop and to withdraw an equal amount of the used end when the tool is given a positive feeding movement.

My invention will be more readily under-

stood from the following specification taken in connection with the accompanying drawings, in which,—

Figure 1 is a side elevation of a machine equipped with the preferred form of my invention; and

Fig. 2 is a top plan view of a portion thereof.

A casing 10, mounted upon a standard 12, contains mechanism for giving to the tool 14 an oscillatory work rubbing movement when power is supplied to the driving pulley 16. An enamel dispensing device 18 is conveniently mounted adjacent the tool and a lever 20 provided which, when depressed, at the will of the operator, allows a positive rotative feeding movement of the tool 14 in a clockwise direction in order to bring a fresh portion of the sheet material used as a cover for said tool into operative relation with the active portion of the surface of the tool. The particular mechanism employed for giving to the tool a work rubbing movement and a positive feeding movement is immaterial so far as this invention is concerned, one form of such a mechanism being sufficiently described in my patent referred to above.

A bracket 22 on the casing 10 extends in a horizontal direction at one side of and in the plane of the axis of said tool and is provided with guides 24 and 26 for a plunger 28 on which is carried a supporting yoke 30. Resilient means such as the spring 32 urges the yoke away from the tool unless restrained by the insertion of a pin 34 in a suitable recess in the plunger. This spring 32 bears at one end against a collar 36 which may be held in various positions to provide for the adjustment of the tension of the spring. This yoke may conveniently be used to support the supply strip of sheet material which is looped around the active portion of the work surface of the tool 14 to act as a cover therefor. Preferably the yoke will also be used to support a mechanism arranged to control the supply of fresh material to said loop and the removal of used material from the loop. An extended strip of sheet material may be wound in a roll 40 around a spool 38 which is pivoted in the outer end of the yoke 30. A weighted roller 42 carried upon a pivoted yoke 44 bears against

the supply roll to frictionally oppose its free rotation and keep the strip from unwinding unduly. Toothed rolls 46 and 48 are pivotally mounted within the yoke 30 and the roll 48 is slidable in said yoke and is urged into engagement with the roll 46 by means of springs 50. The incoming supply strip 52 of the material 40 is passed between the rolls 46 and 48 and then looped around the peripheral work surface of the tool 14, the free end 54 being passed again between said rolls and clamped in contact with the supply strip 52 by the action of the springs 50.

It will be evident that with the arrangement described, the fresh portion 52 of the strip of sheet material is clamped in engagement with the used portion 54 thereof and the loop passing around the tool 14 maintained taut around the roll 46 in such a manner that any oscillatory work rubbing movements of the tool 14 will be shared by the loop. When the tool 14 is given a positive rotative feeding movement at the will of the operator, a fresh portion of the supply end 52 will be drawn into the loop and an equal portion of the used end 54 discarded, thereby effecting simultaneously the discard of a portion of used sheet material and the supply of an equal portion of fresh material.

Although I have herein shown the preferred embodiment of my invention, it is to be understood that I intend to cover in the appended claims all those equivalent arrangements which fall within the true scope and spirit of the invention.

Having fully described my invention, what I claim as new and desire to secure by Letters Patent of the United States is:—

1. In a machine of the class described, a tool having a peripheral work surface, a strip of sheet material adapted to be used as a cover for said tool, said tool and cover being arranged for work rubbing movement and rotative feeding movement, and means for holding a portion of said strip of sheet material in a loop around said tool, said loop comprising incoming and outgoing runs, said means operating also to withdraw from the loop an amount of said strip material equal to the amount of fresh strip material supplied to the loop by the incoming run during the feeding movement of the tool.

2. In a machine of the class described, a tool having a peripheral work surface, a supply strip of sheet material adapted to be looped around the active portion of the work surface of said tool, the loop thus made comprising incoming and outgoing runs, said tool and loop being arranged for work rubbing movement and for rotative feeding movement to bring a fresh portion of the covered work surface into operative relation with the work, and a single mechanism arranged to control the supply of fresh strip

material to the loop on the incoming run and the withdrawal of used strip material from the loop on the outgoing run.

3. In a machine of the class described, a tool having a peripheral work surface, a supply strip of sheet material adapted to be passed around the active portion of the work surface of said tool in a loop, said loop comprising incoming and outgoing runs, means for keeping said loop taut, said tool and loop being arranged for work rubbing movement and for rotative feeding movement to bring a fresh portion of the covered work surface into operative relation with the work, and means for effecting simultaneously the withdrawal of a portion of used sheet material from the loop on the outgoing run and the supply of an equal portion of fresh material to the loop on the incoming run.

4. In a machine of the type described, a work tool having a peripheral work surface, a supply strip of sheet material adapted to be wrapped around the active portion of the work surface of said tool to form a substantially closed loop, said loop comprising incoming and outgoing runs, means for keeping said loop taut, said tool and loop being arranged for work rubbing movement and for positive rotative feeding movement, and means for maintaining a used portion of said strip material in contact with the incoming run or fresh portion thereof, the construction and arrangement being such that used strip material will be withdrawn from the loop on the outgoing run and fresh strip material simultaneously supplied by a feeding movement of the tool.

5. In a machine of the type described, a tool having a peripheral work surface, a supply strip of sheet material wound in a roll, means for frictionally engaging said roll to keep the same from freely unwinding, said tool being arranged for work rubbing movement and for positive rotative feeding movement, a yoke adjacent said tool, toothed rolls pivoted in said yoke, means for resiliently pressing said rolls into engagement to clamp the fresh and used portions of a loop of the sheet material passed between said rolls and wound around the tool, and means for urging said yoke away from said tool to maintain said loop taut.

6. In a machine of the type described, a tool having a peripheral work surface, a supply strip of sheet material adapted to be wrapped around the active portion of the work surface of said tool to form a closed loop, rotatable means for engaging the inner surface of a portion of said loop, means for urging said rotatable means away from said tool to keep the loop taut, said tool and loop being arranged for work rubbing movement and positive rotative feeding movement, and moveable means for engaging the

incoming supply strip and the free end of said strip between itself and the rotatable means, the construction and arrangement being such that said tool and loop may be given an oscillatory work rubbing movement and the loop maintained taut.

7. In a machine of the class described, a tool having a peripheral work surface, a supply strip of sheet material adapted to be looped around the active portion of the work surface of said tool, said tool and loop being arranged for work rubbing movement and for positive rotative feeding movement, and movable clamping and feeding means engaging the incoming supply strip and the free end of said strip and arranged to cause the feeding movement of the incoming supply strip to withdraw from the loop an equal used portion adjacent to the free end of the strip.

8. In a machine of the type described, a tool having a peripheral work surface, a supply strip of sheet material, a support adjacent to said tool, rolls mounted on said support, resilient means holding said rolls in frictional engagement, said supply strip being adapted to be passed between said rolls around said tool and back between said rolls to form a loop inclosing said tool, and means for urging said support away from said tool to keep said loop taut whereby a rotation of said tool in one direction will draw in a fresh portion of said strip and thereby simultaneously withdraw from the loop an equal amount of the used portion of said strip.

9. The combination with a rotary tool arranged for work rubbing movement and for feeding movement, and adapted to receive one end of a loop of sheet material having

a free end, of a pair of feed rollers adapted to receive between them the incoming run of the loop and the free end of the outgoing run, and means for forcing the rollers away from the tool to keep the loop taut, whereby on the feeding movement of the tool a portion of unused sheet material will be supplied thereto and a corresponding portion of used material at the free end of the sheet will be fed between the rolls to be discarded.

10. The combination with a rotary tool arranged for work rubbing movement and for feeding movement, and adapted to receive one end of a loop of sheet material having a free end, of mechanism adapted to receive the incoming run of the loop and the free end of the outgoing run and to keep the loop taut, said mechanism being arranged automatically to supply a portion of unused sheet material to the incoming run of the loop and to withdraw a corresponding portion of used material adjacent to the free end of the outgoing run, when the tool is given a feeding movement.

11. In a machine of the class described, a tool having a peripheral work surface, a strip of sheet material adapted to be used as a cover for said tool, said tool and cover being arranged for work rubbing movement and rotative feeding movement, and means for holding a portion of said strip of sheet material in a loop around said tool constructed and arranged to cause a used free end of the loop to be run off intermittently and fresh strip material correspondingly run into the loop upon successive feeding movements of the tool.

In testimony whereof I have signed my name to this specification.

FREDERICK M. FURBER.