

E. H. SMITH.  
Sewing Machine.

No. 18,359.

Patented Oct. 6, 1857.

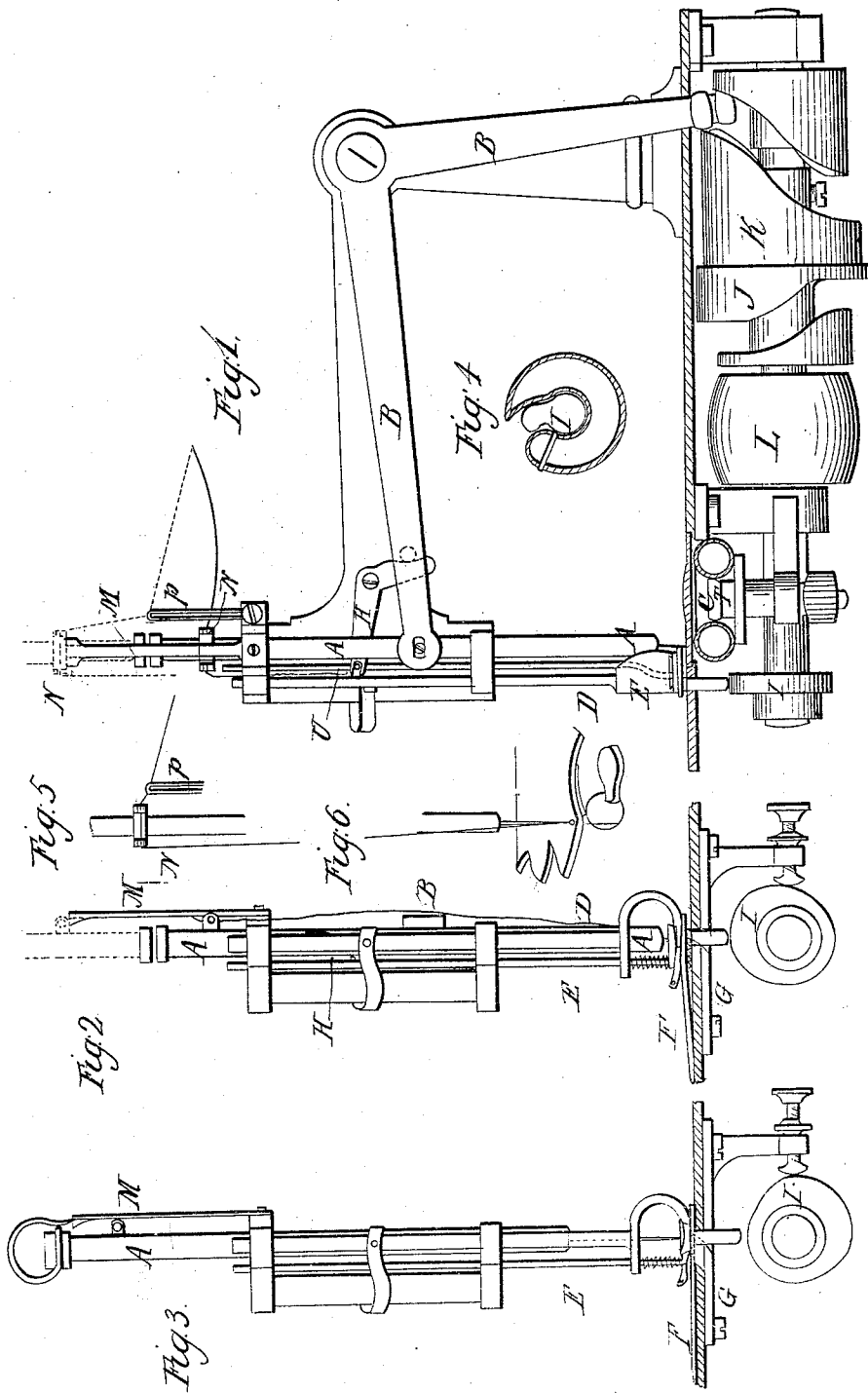

# UNITED STATES PATENT OFFICE.

E. HARRY SMITH, OF NEW YORK, N. Y.

## IMPROVEMENT IN SEWING-MACHINES.

Specification forming part of Letters Patent No. **18,359**, dated October 6, 1857.

*To all whom it may concern:*

Be it known that I, E. HARRY SMITH, of the State, city, and county of New York, have invented certain new and useful Improvements in Sewing - Machines; and I hereby declare the following to be a full, clear, and exact description of the same, reference being had to the accompanying drawings, which form a part of this specification, in which—

Figure 1 is a side elevation of the whole, showing the shuttle in cross-section. Fig. 2 is an end elevation, showing the feeding and the needle down. Fig. 3 is a similar view with the needle up. Fig. 4 shows the shuttle in a section taken with the plane of its rotation, and exhibiting the "cop" in its interior. Fig. 5 represents the method of drawing the loop from off the shuttle by a positive action upon the thread at a given point in the upward motion of the needle.

A is the needle-bar; B, vibrating arm; C, the shuttle; D, pressure-foot; E, smaller or auxiliary foot; F, vibrating guard; G, feeding teeth and bar; H, bent lever; I, cam of feeding motion; J, cam of shuttle; K, cam of needle; L, driving-pulley. M N O P are parts of the thread-controller; T, shuttle guide and driver.

To enable others to make and use my invention, I will proceed to describe its construction and operation.

The nature of my invention consists—

First. In constructing the shuttles of sewing-machines in the form of an annular hollow cylinder, Fig. 4. Into the interior of this there is inserted a cop, one end being made with a detachable cap, which is removed on inserting the cop. The shuttle is supported by a circular disk, in the center of which there is provided a fixed guide and driver, T, so corresponding with the inner periphery of the shuttle and its heel and point as to answer the purpose of holding it in place and driving it around. By constructing the shuttle of this annular or ring form it becomes practicable to support, guide, and drive it from its one or loop side only, without the necessity of using any plate or other equivalent on its opposite side.

Second. In giving the needle a continuous movement, without the rest usual in ordinary shuttle-machines, for the purpose of lifting the shuttle off its bearings and causing it to be

supported by the loop of needle-thread through which it passes, as well as to withdraw it from contact with its guide and driver T, thus greatly reducing the friction of the shuttle as usually arranged to slide in a race, dispensing with the sliding shuttle and its race entirely, and consequently obviating the use of oil on the shuttle, which is always likely to soil the thread. The continuous movement of the needle is here shown as derived from the cam K. A crank or eccentric may be used, however, and in many respects is a superior device.

Third. In the method of controlling the thread in the downward motion of the needle between the needle's eye and the cloth, and a method of producing a positive withdrawal of the loop of needle-thread from the heel of the shuttle when it has passed through. The needle-bar carries ten eyes in a thread-guide, N. The thread is passed through these eyes, and in the descent of the needle-bar it is deposited on the top of the stationary forked thread-support M, where it remains until the needle's eye reaches the cloth, when the detacher O throws it off to allow the needle to carry it into the cloth. The detacher O is secured to the needle-bar between two knots, by which it is rendered adjustable. The arrangement for drawing the loop off the heel of the shuttle consists of a slotted thread-guide, P, affixed to the frame and rendered adjustable by a screw, and a traveling thread-guide, N, permanently affixed to the needle-bar. When the traveling guide is below the top of the fixed guide on the frame, the shuttle has full sway of the thread, and continues to have until, in the upward movement of the needle, the two are brought into the relation shown in Fig. 5, when immediately the traveling thread-guide begins to draw on the thread to pull up the loop, the shuttle having in the meantime passed completely through it. Thus a positive withdrawal of the loop from the shuttle is effected without stopping the needle in its upward movement until the shuttle has passed through the loop. When the loop has been drawn above the cloth, the several parts are in the position shown by the dotted lines in Fig. 1.

Fourth. The grooved cams which give motion to the needle and shuttle differ essentially from all others heretofore known in the matter of the grooves and their adaptation to

tappets in such a manner as greatly to reduce their noise and wear. Instead of cutting a simple groove in a small drum and using a single tappet or roller, alternately reversing its motion, I make the cam with one side of its groove higher than the other, leaving the cam on opposite sides of the groove of larger and smaller diameters, respectively, and use two tappets, each of which bears constantly on one or its own side of the groove only, and consequently are always in motion, each in its own direction and in contrary directions in relation to each other. In connection with this method of construction, the two sides of the groove are also made to be two separate sections of the cam as a whole. One of the two sections is provided with a set-screw, to admit of its being adjusted on the shaft so as to preserve the contact with the tappets or rollers.

Fifth. In the construction of the feeding apparatus a sliding bar, G, is provided on the under side of the platform, on the top of which there are a series of teeth, which protrude upward to take hold of the cloth. On the top of the platform there is a guard, F, which surrounds the teeth. One end of the guard is attached to the platform, while the end near the needle is made to communicate with the operating mechanism below the platform, which imparts to it an up-and-down motion vertically vibratory. The foot D, which holds the cloth to the action of the feeding-teeth, has a part removed and a smaller foot inserted immediately over the feeding-teeth, merely large enough to cover them. This and the larger foot are attached to rods which slide in guides parallel with the movement of the needle. The rod to which the smaller foot is fixed has a small projection at *n*, which works in a slit in the end of a bent lever, H. This lever is operated intermittently by the vibrating arm B, it being provided with a stub, *v*, for the purpose. The larger foot is also furnished with small teeth *y*, hung at the back and kept in contact with the cloth by springs or other convenient device, the teeth being hinged at one end, to not interfere with the cloth as it is carried along by the feeding-teeth on the opposite side, but performs an important office in preventing its being drawn backward as the feeding-teeth return.

No method of actuating the shuttle is represented in the drawings, as there are numerous ways of doing it, none of which form any part of my invention or of the subject-matter of this application. Motion is communicated through the pulley *l*.

The operation of the needle and shuttle is very similar to that in other needle and shuttle sewing-machines, excepting that the needle, instead of remaining at rest while the shuttle is passing through the loop, has a continuous upward movement, tending to lift the shuttle off its bearings and suspend it from the under side of the platform by the loop of needle-thread. From the shape of the shuttle its

motion is necessarily rotative. Its rotation, however, may be reciprocatory or continuous.

The arrangement for controlling the thread in the descent of the needle operates as follows: When the needle-bar is raised to the point indicated by the dotted lines in Figs. 1 and 2, the thread-guide N is just above the stationary thread-support M, and the eyes of N, passing on either side of M, cause it to take the thread and support it until the needle's eye approaches the cloth. On the top of the needle-bar there is a curved finger or detacher, O, the extremity of which exactly corresponds in its width to the space between the projections of the thread-support M. This finger bears such a relation to the range of the needle's movement as to detach the thread from the support M at the moment the eye of the needle reaches the cloth. When the needle again ascends, the thread is again caught on the top of M, and as it descends is again detached by the finger, as before. The detacher or finger O is so secured to the needle-bar as to admit of its adjustment to different heights, according to the thickness of the material to be sewed.

The feeding mechanism is operated partly by the cam I below and by the vibrating arm B above the cloth. The cam I is represented in Fig. 3 as striking the sliding feed-bar and carrying the material forward. The small foot is represented as pressing the cloth onto the feed-teeth to cause them to act effectively. The needle is just about to enter the cloth. After it has entered, Figs. 1 and 2, the vibrating arm B, by its stud, strikes the bent lever H, which raises the small foot, and thus removes a portion of the pressure from immediately over the feeding-teeth. At the same time the cam I comes in contact with the downward projection of the guard F, and, raising, it removes the cloth from contact with the teeth on the bar G. The small teeth Y, above the cloth in the larger foot, assist to hold the cloth and prevent its being dragged backward by the feeding-teeth in case the small foot should fail to rise at the proper time sufficiently to remove the pressure from over the feed.

I claim as my invention and desire to secure by Letters Patent—

1. A cylindrical annular shuttle, constructed as described, in combination with the driver for holding it in place and driving it around.

2. In combination with the above, imparting to the needle and its thread a constant upward movement while the shuttle passes through the loop, so as to lift the shuttle completely off its bearings, and thus avoid all friction of a sliding shuttle and the use of oil thereon.

3. In combination with the above continuous movement, the two thread-guides, as arranged and made to operate together with respect to the needle's movement and that of the shuttle, essentially in the manner set forth and represented, for the purpose of causing a positive withdrawal of the loop from the shuttle

at the moment the latter has passed through it.

4. The employment of the smaller or auxiliary foot to hold the cloth to the feeding-teeth in their forward movement, and to release the pressure therefrom when they return, substantially as set forth.

5. The use of a series of laterally-reciprocating teeth to carry the cloth along in their forward movement, in combination with a se-

ries of vertically-acting teeth to assist in holding the cloth and counteract the retrograde tendency in the return of the feed, when such teeth act independently of the foot to which they are attached.

E. HARRY SMITH.

Witnesses:

S. T. McDOUGALL,

T. LEHR.