

(19) World Intellectual Property Organization  
International Bureau



(43) International Publication Date  
10 November 2005 (10.11.2005)

PCT

(10) International Publication Number  
WO 2005/105010 A1

- (51) International Patent Classification<sup>7</sup>: A61F 13/15
- (74) Common Representative: REED, David, T. et al.; The Procter & Gamble Company, Winton Hill Business Center, 6110 Center Hill Road, Cincinnati, OH 45224 (US).
- (21) International Application Number: PCT/US2005/012536
- (81) Designated States (unless otherwise indicated, for every kind of national protection available): AE, AG, AL, AM, AT, AU, AZ, BA, BB, BG, BR, BW, BY, BZ, CA, CH, CN, CO, CR, CU, CZ, DE, DK, DM, DZ, EC, EE, EG, ES, FI, GB, GD, GE, GH, GM, HR, HU, ID, IL, IN, IS, JP, KE, KG, KM, KP, KR, KZ, LC, LK, LR, LS, LT, LU, LV, MA, MD, MG, MK, MN, MW, MX, MZ, NA, NI, NO, NZ, OM, PG, PH, PL, PT, RO, RU, SC, SD, SE, SG, SK, SL, SM, SY, TJ, TM, TN, TR, TT, TZ, UA, UG, US, UZ, VC, VN, YU, ZA, ZM, ZW.
- (22) International Filing Date: 14 April 2005 (14.04.2005)
- (25) Filing Language: English
- (26) Publication Language: English
- (30) Priority Data: 10/824,122 14 April 2004 (14.04.2004) US
- (71) Applicant (for all designated States except US): THE PROCTER & GAMBLE COMPANY [US/US]; One Procter & Gamble Plaza, Cincinnati, OH 45202 (US).
- (72) Inventors; and
- (75) Inventors/Applicants (for US only): ASHTON, Gregory [US/US]; 10290 Stablehand Drive, Cincinnati, OH 45242 (US). FUKUDA, Eiro [JP/US]; 8240 Cora Court, Mason, OH 45040 (US). NISHIKAWA, Masaharu [JP/US]; 11210 Acrewood Drive, Cincinnati, OH 45249 (US).
- (84) Designated States (unless otherwise indicated, for every kind of regional protection available): ARIPO (BW, GH, GM, KE, LS, MW, MZ, NA, SD, SL, SZ, TZ, UG, ZM, ZW), Eurasian (AM, AZ, BY, KG, KZ, MD, RU, TJ, TM), European (AT, BE, BG, CH, CY, CZ, DE, DK, EE, ES, FI, FR, GB, GR, HU, IE, IS, IT, LT, LU, MC, NL, PL, PT, RO, SE, SI, SK, TR), OAPI (BF, BJ, CF, CG, CI, CM, GA, GN, GQ, GW, ML, MR, NE, SN, TD, TG).

[Continued on next page]

(54) Title: DUAL CUFF FOR A UNITARY DISPOSABLE ABSORBENT ARTICLE MADE OF A CONTINUOUS CUFF MATERIAL

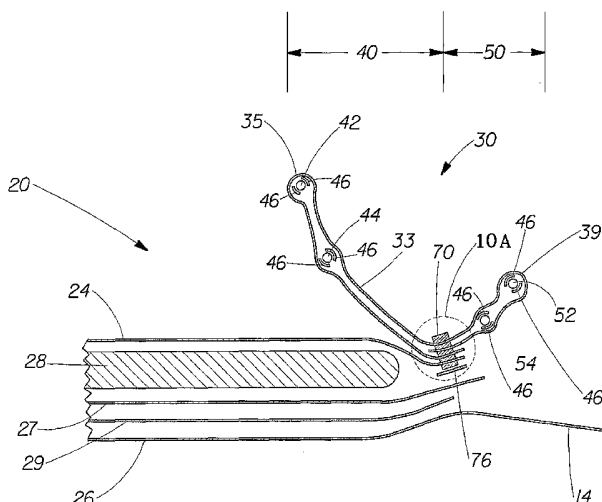

(57) Abstract: A unitary disposable absorbent article includes: an absorbent core having a garment surface and a body surface, a liquid permeable topsheet positioned adjacent said body surface of said absorbent core, a liquid impermeable backsheet positioned adjacent said garment surface of said absorbent core and an elastically contractible dual cuff. The dual cuff has a proximate end and a distal end. The dual cuff is joined to the article by a cuff bond. The dual cuff has a first cuff and a second cuff. The first cuff is disposed between the proximate end and the cuff bond. The second cuff is disposed between the cuff bond and the distal end. The dual cuff is constructed of a continuous cuff material and enclosed by the cuff bond. It may be desirable for the cuff material to only be bonded to itself by the cuff bond.

WO 2005/105010 A1



**Published:**

— *with international search report*

*For two-letter codes and other abbreviations, refer to the "Guidance Notes on Codes and Abbreviations" appearing at the beginning of each regular issue of the PCT Gazette.*

**DUAL CUFF FOR A UNITARY DISPOSABLE ABSORBENT ARTICLE  
MADE OF A CONTINUOUS CUFF MATERIAL**

Field of Invention

This invention relates to dual cuffs on absorbent articles, and more particularly to dual cuffs having a first cuff and a second cuff on disposable absorbent articles, such as diapers.

Background of the Invention

The major function of absorbent articles, such as disposable diapers and adult incontinent briefs, is to absorb and contain body exudates. Such articles are thus intended to prevent body exudates from soiling, wetting, or otherwise contaminating clothing or other articles, such as bedding, that come in contact with the wearer. One common mode of failure for such products occurs when body exudates leak out of the gaps between the article and the wearer's leg to adjacent clothing because they are not immediately absorbed within the article. For example, urine tends to wick through the topsheet to the edges of the absorbent article where it can come in contact with clothing or other articles. Additionally, loose fecal material that is not easily absorbed by the absorbent article tends to "float" on the liquid-receiving surface and work its way past the legs of the wearer.

Contemporary absorbent articles have a topsheet, a backsheet, an absorbent core, a barrier cuff and a gasketing cuff. The gasketing cuff proves effective generally to prevent wicking and overflow from the fluid laden article to clothing contacting the edges of the article in that the gasketing cuff presents a fluid impermeable barrier between the edge of the article and the contacting clothing, and in addition, provides a gasketing action about the legs of the wearer. The barrier cuff proves effective generally to inhibit loose fecal material or gushes of urine or liquids from soiling the wearer's clothing. The barrier cuff restrains the free flow of this material and provides a structure to hold such material within the article.

While providing an inner and an outer cuff within an absorbent article has its advantages, the resulting article is often too wide in the crotch area, thus causing discomfort for the wearer. Furthermore, the outer cuff typically has an unfinished appearance that further adds to the perception of discomfort. Therefore, what is needed is an absorbent article that provides both effectiveness and comfort in the cuff region.

### Summary of the Invention

A unitary disposable absorbent article includes: an absorbent core having a garment surface and a body surface, a liquid permeable topsheet positioned adjacent said body surface of said absorbent core, a liquid impermeable backsheet positioned adjacent said garment surface of said absorbent core and an elastically contractible dual cuff.

The dual cuff has a proximate end and a distal end. The dual cuff is joined to the article by a cuff bond. The dual cuff has a first cuff and a second cuff. The first cuff is disposed between the proximate end and the cuff bond. The second cuff is disposed between the cuff bond and the distal end. The dual cuff is constructed of a continuous cuff material and enclosed by a cuff bond. It may be desirable for the cuff material to only be bonded to itself by the cuff bond.

The first cuff envelopes at least one elastic which is operatively associated with the first cuff by securing it with an elastic attachment element. The elastic is secured to the first cuff near its ends or along its entire length.

The second cuff envelopes at least one elastic which is operatively associated with the second cuff by securing it with an elastic attachment element. The elastic is secured to the second cuff near its ends or along its entire length.

The absorbent article may be a disposable diaper. The absorbent article may be a prefastened diaper.

### Brief Description of the Drawings

While the specification concludes with claims pointing out and distinctly claiming the present invention, it is believed the same will be better understood by the following drawings taken in conjunction with the accompanying specification wherein like components are given the same reference number.

FIG. 1 is a plan view of a disposable diaper embodiment of the present invention having portions cut-away to reveal underlying structure;

FIG. 2 is a fragmentary sectional view taken along section line 2-2 of FIG. 1;

FIG. 3a is a top view taken within encircled portion 3 of FIG. 1 illustrating a prior art example of a dual cuff within the crotch region;

FIG. 3b is a cross-sectional view of FIG. 3a;

FIG. 4a is a top view taken within encircled portion 3 of FIG. 1 illustrating an absorbent article having a dual cuff in accordance with the present invention within the crotch region;

FIG. 4b is a cross-sectional view of FIG. 4a;

FIG. 5 is a fragmentary sectional view taken along section line 5-5 of FIG. 1;

FIG. 6 is a fragmentary sectional view of another embodiment taken along section line 2-2 of FIG. 1;

FIG. 7 is a fragmentary sectional view of yet another embodiment taken along section line 2-2 of FIG. 1;

FIG. 8 is a fragmentary sectional view of yet another embodiment taken along section line 2-2 of FIG. 1; and

FIG. 9 is a fragmentary sectional view of yet another embodiment taken along section line 2-2 of FIG. 1;

FIG. 10a is a close-up view taken within encircled portion 10 of FIG. 2 illustrating a fold-over technique of cuff material, wherein a lower cuff material end is positioned longitudinally outboard of cuff bond; and

FIG. 10b is a close-up view taken within encircled portion 10 of FIG. 2 illustrating a fold-over technique of cuff material, wherein a lower cuff material end is positioned longitudinally inboard of cuff bond.

#### Detailed Description of the Invention

As used herein, the following terms have the following meanings:

"Absorbent article" refers to devices that absorb and contain liquid, and more specifically, refers to devices that are placed against or in proximity to the body of the wearer to absorb and contain the various exudates discharged from the body.

"Longitudinal" is a direction running parallel to the maximum linear dimension of the article and includes directions within  $\pm 45^\circ$  of the longitudinal direction.

The "lateral" or "transverse" direction is orthogonal to the longitudinal direction.

The "Z-direction" is orthogonal to both the longitudinal and transverse directions.

The "x-y plane" refers to the plane congruent with the longitudinal and transverse directions.

The term "disposable" is used herein to describe absorbent articles that generally are not intended to be laundered or otherwise restored or reused as an absorbent article (i.e., they are intended to be discarded after a single use and, preferably, to be recycled, composted or otherwise disposed of in an environmentally compatible manner).

As used herein, the term "disposed" is used to mean that an element(s) is formed (joined and positioned) in a particular place or position as a unitary structure with other elements or as a separate element joined to another element.

As used herein, the term "joined" encompasses configurations whereby an element is directly secured to another element by affixing the element directly to the other element, and

configurations whereby an element is indirectly secured to another element by affixing the element to intermediate member(s) which in turn are affixed to the other element.

A "unitary" absorbent article refers to absorbent articles which are formed of separate parts united together to form a coordinated entity so that they do not require separate manipulative parts like a separate holder and liner.

As used herein, the term "diaper" refers to an absorbent article generally worn by infants and incontinent persons about the lower torso.

The terms "water-permeable" and "water-impermeable" refer to the penetrability of materials in the context of the intended usage of disposable absorbent articles. Specifically, the term "water-permeable" refers to a layer or a layered structure having pores, openings, and/or interconnected void spaces that permit liquid water to pass through its thickness in the absence of a forcing pressure. Conversely, the term "water-impermeable" refers to a layer or a layered structure through the thickness of which liquid water cannot pass in the absence of a forcing pressure. A layer or a layered structure that is water-impermeable according to this definition may be permeable to water vapor, *i.e.*, may be "vapor-permeable". As is well known in the art, a common method for measuring the permeability to water of the materials typically used in absorbent articles is a hydrostatic pressure test, also called a hydrostatic head test or simply a "hydrohead" test. Suitable well known compendial methods for hydrohead testing are approved by INDA (formerly the International Nonwovens and Disposables Association, now The Association of the Nonwoven Fabrics Industry) and EDANA (European Disposables And Nonwovens Association).

The terms "proximal" and "distal" refer respectively to the location of an element near to or far from the center of a structure, *e.g.*, the proximal edge of a longitudinally extending element is located nearer to the longitudinal axis than the distal edge of the same element is located relative to the same longitudinal axis.

As used herein, the term "barrier cuff" refers to an elasticized flap which stands substantially upright, more preferably inwardly towards the longitudinal centerline, within the crotch region. Typically, said barrier cuff envelopes/contains at least one elastic that is connected primarily at its opposing ends to the diaper (*e.g.*, drawstring technique for better fit).

As used herein, the term "gasketing cuff" refers to an elasticized flap which does not stand substantially upright, more preferably outwardly towards the longitudinal side edges of the diaper, within the crotch region. Typically, said gasketing cuff envelopes/contains at least one elastic that is connected substantially throughout its length to the diaper (*e.g.*, multiple bonds along length of elastic to create gathers).

Figure 1 is a plan view of an exemplary, non-limiting embodiment of a diaper 20 of the present invention in its flat-out, uncontracted state (i.e., without elastic induced contraction) with portions of the structure being cut away to more clearly show the underlying structure of the diaper 20 and with the portion of the diaper 20 which contacts the wearer facing the viewer. The diaper 20 includes a longitudinal axis 1000 and a lateral axis 1100. One end portion 36 of the diaper 20 is configured as a first waist region 36 of the diaper 20. The opposite end portion 38 is configured as a second waist region 38 of the diaper 20. An intermediate portion 37 of the diaper 20 is configured as a crotch region 37, which extends longitudinally between the first and second waist regions 36 and 38. The waist regions 36 and 38 generally comprise those portions of the diaper 20 which, when worn, encircle the waist of the wearer. The waist regions 36 and 38 may include elastic elements such that they gather about the waist of the wearer to provide improved fit and containment. The crotch region 37 is that portion of the diaper 20 which, when the diaper 20 is worn, is generally positioned between the legs of the wearer. The outer periphery of diaper 20 is defined by longitudinal edges 14 and end edges 10, 12 which are located along the first and second waist region 36, 38, respectively.

The chassis 22 of the diaper 20 comprises the main body of the diaper 20. The chassis 22 comprises an outer covering including a liquid permeable topsheet 24 and/or a liquid impermeable backsheet 26 (see FIG. 2) and at least a portion of an absorbent core 28 encased between the topsheet 24 and the backsheet 26. For unitary absorbent articles, the chassis 22 comprises the main structure of the diaper with other features added to form the composite diaper structure. While the topsheet 24, the backsheet 26, and the absorbent core 28 may be assembled in a variety of well-known configurations, preferred diaper configurations are described generally in U.S. Pat. No. 3,860,003 entitled "Contractible Side Portions for Disposable Diaper" issued to Kenneth B. Buell on January 14, 1975; U.S. Pat. No. 5,151,092 issued to Buell on September 9, 1992; and U.S. Pat. No. 5,221,274 issued to Buell on June 22, 1993; and U.S. Pat. No. 5,554,145 entitled "Absorbent Article With Multiple Zone Structural Elastic-Like Film Web Extensible Waist Feature" issued to Roe et al. on September 10, 1996; U.S. Pat. No. 5,569,234 entitled "Disposable Pull-On Pant" issued to Buell et al. on October 29, 1996; U.S. Pat. No. 5,580,411 entitled "Zero Scrap Method For Manufacturing Side Panels For Absorbent Articles" issued to Nease, et al. on December 3, 1996; and U.S. Patent No. 6,004,306 entitled "Absorbent Article With Multi-Directional Extensible Side Panels" issued to Robles et al. on December 21, 1999; each of which is incorporated herein by reference.

The topsheet 24 may be fully or partially elasticized or may be foreshortened so as to provide a void space between the topsheet 24 and the core 28. Exemplary structures including elasticized or foreshortened topsheets are described in more detail in U.S. Pat. No. 4,892,536

issued to DesMarais et al. on January 9, 1990 entitled "Absorbent Article Having Elastic Strands"; U.S. Pat. No. 4,990,147 issued to Freeland on February 5, 1991 entitled "Absorbent Article With Elastic Liner For Waste Material Isolation"; U.S. Pat. No. 5,037,416 issued to Allen et al. on August 6, 1991 entitled "Disposable Absorbent Article Having Elastically Extensible Topsheet"; and U.S. Pat. No. 5,269,775 issued to Freeland et al. on December 14, 1993 entitled "Trisection Topsheets For Disposable Absorbent Articles and Disposable Absorbent Articles Having Such Trisection Topsheets"; each of which is incorporated by reference herein.

The absorbent core 28 may comprise any absorbent material that is generally compressible, conformable, non-irritating to the wearer's skin, and capable of absorbing and retaining liquids such as urine and other certain body exudates. The absorbent core 28 may comprise a wide variety of liquid-absorbent materials commonly used in disposable diapers and other absorbent articles such as comminuted wood pulp, which is generally referred to as air felt. Examples of other suitable absorbent materials include creped cellulose wadding; melt blown polymers, including co-form; chemically stiffened, modified or cross-linked cellulosic fibers; tissue, including tissue wraps and tissue laminates; absorbent foams; absorbent sponges; superabsorbent polymers; absorbent gelling materials; or any other known absorbent material or combinations of materials.

Exemplary absorbent structures for use as the absorbent assemblies are described in U.S. Patent 4,610,678 entitled "High-Density Absorbent Structures" issued to Weisman et al. on September 9, 1986; U.S. Patent 4,673,402 entitled "Absorbent Articles With Dual-Layered Cores" issued to Weisman et al. on June 16, 1987; U.S. Patent 4,834,735, entitled "High Density Absorbent Members Having Lower Density and Lower Basis Weight Acquisition Zones", issued to Alemany et al. on May 30, 1989; U.S. Patent 4,888,231 entitled "Absorbent Core Having A Dusting Layer" issued to Angstadt on December 19, 1989; U.S. Patent No. 5,137,537 entitled "Absorbent Structure Containing Individualized, Polycarboxylic Acid Crosslinked Wood Pulp Cellulose Fibers" which issued to Herron et al. on August 11, 1992; U.S. Patent 5,147,345 entitled "High Efficiency Absorbent Articles For Incontinence Management" issued to Young et al. on September 15, 1992; U.S. Patent No. 5,342,338 entitled "Disposable Absorbent Article For Low-Viscosity Fecal Material" issued to Roe on August 30, 1994; U.S. Patent No. 5,260,345 entitled "Absorbent Foam Materials For Aqueous Body Fluids and Absorbent Articles Containing Such Materials" issued to DesMarais et al. on November 9, 1993; U.S. Patent No. 5,387,207 entitled "Thin-Until-Wet Absorbent Foam Materials For Aqueous Body Fluids And Process For Making Same" issued to Dyer et al. on February 7, 1995; U.S. Pat. No. 5,397,316 entitled "Slitted Absorbent Members For Aqueous Body Fluids Formed Of Expandable Absorbent Materials" issued to LaVon et al. on March 14, 1995; and U.S. Patent No. 5,625,222 entitled "Absorbent

Foam Materials For Aqueous Fluids Made From high Internal Phase Emulsions Having Very High Water-To-Oil Ratios" issued to DesMarais et al. on July 22, 1997. Each of these patents is incorporated herein by reference.

The backsheet 26 is generally that portion of the diaper 20 positioned adjacent the garment-facing surface of the absorbent core 28. Backsheet 26 prevents the exudates absorbed and contained therein from soiling articles that may contact the diaper 20, such as bed sheets and undergarments. In preferred embodiments, the backsheet 26 is substantially impermeable to liquids (e.g., urine) and comprises a laminate of a nonwoven and a thin plastic film such as a thermoplastic film having a thickness of about 0.012 mm (0.5 mil) to about 0.051 mm (2.0 mils). Suitable backsheet films include those manufactured by Tredegar Industries Inc. of Terre Haute, IN and sold under the trade names X15306, X10962, and X10964. Other suitable backsheet materials may include breathable materials that permit vapors to escape from the diaper 20 while still preventing exudates from passing through the backsheet 26. Exemplary breathable materials may include materials such as woven webs, nonwoven webs, composite materials such as film-coated nonwoven webs, and microporous films such as manufactured by Mitsui Toatsu Co., of Japan under the designation ESPOIR NO and by EXXON Chemical Co., of Bay City, TX, under the designation EXXAIRE. Suitable breathable composite materials comprising polymer blends are available from Clopay Corporation, Cincinnati, OH under the name HYTREL blend P18-3097. Such breathable composite materials are described in greater detail in PCT Application No. WO 95/16746, published on June 22, 1995 in the name of E. I. DuPont and copending U.S. Patent Application Serial No. 08/744,487, filed on November 6, 1996 in the name of Curro. Other breathable backsheets including nonwoven webs and apertured formed films are described in U.S. Patent No. 5,571,096 issued to Dobrin et al. on November 5, 1996. An exemplary, suitable backsheet is disclosed in U.S. Patent No. 6,107,537 entitled "Disposable absorbent articles providing a skin condition benefit" issued to Elder et al on August 22, 2000. Other suitable materials and/or manufacturing techniques may be used to provide a suitable backsheet 26 including, but not limited to, surface treatments, particular film selections and processing, particular filament selections and processing, etc. Each of these references is hereby incorporated by reference herein.

Backsheet 26 may also consist of more than one layer, as exemplified in FIG. 1, wherein a backsheet outer layer 26 (often referred to as the backsheet) may be made of a soft, non-woven material and a backsheet inner layer 27 may be made of a substantially impermeable film. Adhesive 29, or any other suitable material or method, may be used to join layers 26 and 27 together. While a variety of backsheet configurations are contemplated herein, it would be

obvious to those skilled in the art that various other changes and modifications can be made without departing from the spirit and scope of the invention.

The diaper 20 may also include a fastening system 55. The fastening system 55 preferably maintains the first waist region 36 and the second waist region 38 in a configuration so as to provide lateral tensions about the circumference of the diaper 20 to hold the diaper 20 on the wearer. The fastening system 55 preferably comprises a fastener such as tape tabs, hook and loop fastening components, interlocking fasteners such as tabs & slots, buckles, buttons, snaps, and/or hermaphroditic fastening components, although any other known fastening means are generally acceptable. Some exemplary surface fastening systems are disclosed in U.S. Patent 3,848,594 entitled "Tape Fastening System for Disposable Diaper" issued to Buell on November 19, 1974; U.S. Patent B1 4,662,875 entitled "Absorbent Article" issued to Hirotsu et al. on May 5, 1987; U.S. Patent 4,846,815 entitled "Disposable Diaper Having An Improved Fastening Device" issued to Scripps on July 11, 1989; U.S. Patent 4,894,060 entitled "Disposable Diaper With Improved Hook Fastener Portion" issued to Nestegard on January 16, 1990; U.S. Patent 4,946,527 entitled "Pressure-Sensitive Adhesive Fastener And Method of Making Same" issued to Battrell on August 7, 1990; the herein before referenced U.S. Pat. No. 5,151,092 issued to Buell on September 9, 1992; and U.S. Pat. No. 5,221,274 issued to Buell on June 22, 1993. An exemplary interlocking fastening system is disclosed in co-pending U.S. Patent No. 6,432,098 entitled "Absorbent Article Fastening Device" in the names of Kline et al. issued on August 13, 2002. The fastening system 55 may also provide a means for holding the article in a disposal configuration as disclosed in U.S. Pat. No. 4,963,140 issued to Robertson et al. on October 16, 1990. The fastening system may also include primary and secondary fastening systems, as disclosed in U.S. Pat. No. 4,699,622 entitled "Disposable Diaper Having An Improved Side Closure" issued to Toussant et al. on October 13, 1987. to reduce shifting of overlapped portions or to improve fit as disclosed in U.S. Pat. No. 5,242,436 entitled "Absorbent Article With Fastening System Providing Dynamic Elasticized Waistband Fit" issued to Weil et al. on September 7, 1993; U.S. Pat. No. 5,499,978 entitled "Absorbent Article With Dynamic Elastic Waist Feature Having A Predisposed Resilient Flexural Hinge" issued to Buell et al. on March 19, 1996; U.S. Pat. No. 5,507,736 entitled "Absorbent Article With Dynamic Elastic Waist Feature Comprising An Expansive Tummy Panel" issued to Clear et al. on April 16, 1996; U.S. Pat. No. 5,591,152 entitled "Absorbent Article With Dynamic Elastic Waist Feature Having A Predisposed Resilient Flexural Hinge" issued to Buell et al. on January 7, 1997. Each of these patents and the co-pending application are incorporated herein by reference.

In alternative embodiments, the article may be preformed by the manufacturer to create a pant. The term "pant", as used herein, refers to disposable garments having a waist opening and

leg openings designed for infant or adult wearers. A pant may be placed in position on the wearer by inserting the wearer's legs into the leg openings and sliding the pant into position about the wearer's lower torso. A pant may be preformed by any suitable technique including, but not limited to, joining together portions of the article using refastenable and/or non-refastenable bonds (e.g., seam, weld, adhesive, cohesive bond, fastener, etc.). While the term "pant" is used herein, pants are also commonly referred to as "closed diapers", "prefastened diapers", "pull-on diapers", "training pants" and "diaper-pants". Suitable pants are disclosed in U.S. Patent No. 5,246,433, issued to Hasse, et al. on September 21, 1993; U.S. Patent No. 5,569,234, issued to Buell et al. on October 29, 1996; U.S. Patent No. 6,120,487, issued to Ashton on September 19, 2000; U.S. Patent No. 6,120,489, issued to Johnson et al. on September 19, 2000; U.S. Patent No. 4,940,464, issued to Van Gompel et al. on July 10, 1990; U.S. Patent No. 5,092,861, issued to Nomura et al. on March 3, 1992; U.S. Patent Application Serial No. 10/171,249, entitled "Highly Flexible And Low Deformation Fastening Device", filed on June 13, 2002; U.S. Patent No. 5,897,545, issued to Kline et al. on April 27, 1999; U.S. Patent No. 5,957,908, issued to Kline et al on September 28, 1999, the disclosure of each of which is incorporated herein by reference.

The diaper 20 may also include such other features as are known in the art including cuffs, front and rear ear panels, waist cap features, elastics and the like to provide better fit, containment and aesthetic characteristics. Such additional features are well known in the art and are described in U.S. Pat. No. 3,860,003; and U.S. Patent No. 5,151,092, which are incorporated by reference herein.

For example, diaper 20 may include barrier cuffs or "stand-up" elasticized flaps, as exemplified in U.S. Pat. Nos. 4,808,178 and 4,909,803 issued to Aziz et al. on Feb. 28, 1989 and Mar. 20, 1990, respectively.

Additionally, diaper 20 may include gasketing cuffs or "leg cuff" elasticized side flaps, as exemplified in U.S. Pat. No. 3,860,003.

A first and second cuff may both be provided by way of a dual cuff, as exemplified in U.S. Pat. Nos. 4,695,278 and 4,795,454 issued to Lawson on Sep. 22, 1987 and to Dragoo on Jan. 3, 1989, respectively.

For example, diaper 20 may include a first cuff 40 which provides improved containment of liquids and other body exudates. First cuff 40 may also be referred to as a barrier leg cuff, inner leg cuffs or "stand-up" elasticized flap. U.S. Pat. Nos. 4,808,178 and 4,909,803 issued to Aziz et al. on Feb. 28, 1989 and Mar. 20, 1990, respectively, describe disposable diapers having "stand-up" elasticized flaps that improve the containment of the leg regions.

Additionally, diaper 20 may include a second cuff 50 which also provides improved containment of liquids and other body exudates. Second cuff 50 may also be referred to as an

outer leg cuff, leg band, side flap, leg cuff or elastic cuff. U.S. Pat. No. 3,860,003 describes a disposable diaper which provides a contractible leg opening having a side flap and one or more elastic members to provide an elasticized leg cuff.

First cuff 40 and second cuff 50 may both be provided by way of a dual cuff 30, as exemplified in U.S. Pat. Nos. 4,695,278 and 4,795,454 issued to Lawson on Sep. 22, 1987 and to Drago on Jan. 3, 1989, respectively.

FIG. 2 is a fragmentary sectional view taken along section line 2-2 of FIG. 1 and depicts the diaper construction in the crotch region 37 of the diaper 20 as it is shaped before being applied to the wearer (i.e., the diaper is subjected to elastic contraction). Dual cuff 30 has a proximate end 35, distal end 39 and regions therebetween identified as first cuff 40 and second cuff 50. Dual cuff 30 may be constructed from a continuous cuff material 33 that substantially envelopes the elastics of first cuff 40 and second cuff 50. More specifically, first cuff 40 has at least one elastic (although two elastics 42, 44 are shown) and second cuff 50 also has at least one elastic (although two elastics 52, 54 are shown) that are enveloped within cuff material 33. In this way, only a continuous cuff material 33 is used and manipulated during the construction of dual cuff 30, thus making easier the manufacturing of said dual cuff. Moreover, cuff material 33 need only be enclosed/bonded at a single location, as exemplified by cuff bond 70, in order to substantially envelope elastics 42, 44, 52, 54, thus providing improved barrier properties by minimizing the number of potential leakable locations (e.g., bonding locations). Herein, "continuous cuff material" means a cuff material that is continuous along a path beginning from the cuff end bond, along said cuff material, and ending at the same cuff end bond such that the dual cuff 30 is substantially constructed of two layers of the materials, whether it be the same or different materials. For example, the continuous cuff material 33 may be constructed of a lesser-water-permeable material (e.g., spunbound material which is inexpensive) with a more-water-permeable material (e.g., meltblown material which is more expensive) placed inside said lesser-water-permeable material. In another example, cuff material 33 may be constructed of a spunbound-meltblown laminate. In yet another example, cuff material 33 may be constructed of a series of various materials so long as they are continuous. In yet another example, cuff material 33 may be treated to increase its hydrophobicity. Such hydrophobic treatments include, but are not limited to, the application of hydrophobic surface coating (as exemplified in co-pending U.S. Patent Application Serial No. 60/543,785, entitled "Hydrophobic Surface Coated Absorbent Articles And Associated Methods", filed on February 11, 2004) and fluoro-treatment (as exemplified in co-pending U.S. Patent Application Serial No. 10/703,239, entitled "Disposable Absorbent Articles With Masking Topsheet", filed on November 7, 2003). In yet another example, it may be

desirable that dual cuff 30 be connected to diaper 20 by way of a single bond (e.g., adhesive, ultrasonic; e.g., cuff bond 70 to topsheet 24).

Cuff bond 70 may extend substantially the entire longitudinal length of diaper 20. Cuff bond 70 may be adhesive, ultrasonic bonding, compression bonding, thermal bonding, combinations thereof, and any other suitable bonding means known in the art which is appropriate for the specific materials employed. Cuff bond 70 may also join dual cuff 30 to topsheet 24. Lastly, an adhesive 76 having liquid impermeability properties may be applied between the topsheet 24 and backsheet 26 (or more specifically shown herein, backsheet inner layer 27) to provide improved barrier properties. Adhesive 76 may be located juxtaposed to intermediate bond 70; however, so long as adhesive 76 helps to provide a containment of exudates, then its actual location is may be variable. LastlyFurther, it may be desirable for the cuff material to only be bonded to itself by the cuff bond (i.e., no other bond similar to cuff bond 70 is used). Lastly, it may be desirable for both first cuff 40 and second cuff 50 to be barrier cuffs.

Elastics 42, 44, 52, 54 may be operatively associated with their respective cuff by securing it within said cuff with an elastic attachment element 46. The elastic attachment element 46 should be flexible and of sufficient adhesiveness to hold elastics 42, 44, 52, 54 in their stretched condition. Elastics 42, 44, 52, 54, having a first and second end, may be secured to their respective cuff only near their ends or along their entire length. Elastic attachment element 46 may be glue beads made of hot melt adhesive such as marketed by Findley Adhesives Incorporated, Elmgrove, Wis., as Findley Adhesives 581. Alternatively, elastic attachment element 46 may take the form of an ultrasonic bond or heat/pressure seal. A more detailed description of the manner in which the elastic attachment element 46 may be positioned and secured to their respective cuff can be found in U.S. Pat. No. 4,081, 301, issued to Buell on Mar. 28, 1978, and in U.S. Pat. No. 4,253,461, issued to Strickland and Visscher on Mar. 3, 1981, both of which are incorporated herein by reference. While elastics 42, 44 in first cuff 40 and elastics 52, 54 in second cuff 50 were shown, it would be obvious to those skilled in the art that one or more elastics may be used in each cuff without departing from the spirit and scope of the invention.

Elastics 42, 44, 52, 54 which have been found suitable are elastic strands having a cross section of 0.18 mm by 1.5 mm and made from natural rubber as available from Easthampton Rubber Company of Stewart, Va., under the trademark L-1900 Rubber Compound. Other suitable elastics can be made from natural rubber, such as elastic tape sold under the trademark Fulflex 9411 by Fulflex Company of Middletown, R. I. Elastics 42, 44, 52, 54 may also comprise any heat shrinkable elastic material as is well known in the art. Other suitable elastic materials may comprise a wide variety of materials as are well known in the art include elastomeric films,

polyurethane films, elastomeric foams, formed elastic scrim and synthetic elastomers (e.g., Lycra™). In addition, elastics 42, 44, 52, 54 may take a multitude of configurations. For example, the width may be varied; a single strand or several parallel or non-parallel strands of elastic material may be used; or a variety of shaped may be used including rectilinear and curvilinear.

Referring now to FIG. 3a, a top view taken within encircled portion 3 of FIG. 1 is shown illustrating a prior art example of a dual cuff 130 within the crotch region 37. FIG 3b depicts a corresponding cross-sectional view of FIG. 3a. Prior art dual cuff 130 is constructed from at least two cuff materials 133 joined together by bonds 160, 170, 175. Prior art dual cuff 130 has a proximate end 135, distal end 139 and regions therebetween identified as first cuff 140 and second cuff 150. More specifically, first cuff 140 has two elastics 142, 144 and second cuff 150 also has two elastics 152, 154 that are enveloped within cuff materials 133.

When measuring the overall width of an absorbent article 20, the widths of dual cuff elements and the distances between each element are considered. For example, referring to FIG. 3a, distance "a" is the length measured from longitudinal edge 128 to cuff distal edge 139a. As background, near the end of the manufacturing process, a side notch cut is made into the backsheet to create an overall hour glass shape to provide leg openings within the crotch region. When making said side notch cut, it is important that the rotary knife, for example, does not inadvertently extend into cuff distal end 139a; otherwise, a perforated piece results that may later be removed by the wearer (e.g., baby) thus causing a safety concern of removing and swallowing said piece. Therefore, in effect, distance "a" is a safety standard against this potential problem. Based on the tracking inaccuracies of a traveling web of material being fed into a rotary knife in the manufacturing of an absorbent article, distance "a" is commonly set at approximately 7mm.

Distance "b" is the length measured from cuff distal edge 139a to cuff distal edge 139b. More specifically, since prior art dual cuff 130 is made by two cuff materials 133 that are joined together by a cuff end bond 160, there exists misalignment issues in placing edges 139a and 139b next to one another. This distance "b" is an inherent property of this prior art dual cuff design and typically measures at approximately 2mm.

Distance "c" is the length measured from cuff distal edge 139b to cuff end bond 160. More specifically, cuff end bond 160 is intended to join cuff distal edges 139a, 139b. To ensure that cuff distal edges 139a, 139b are in fact joined in a bonding roll, and based on the tracking inaccuracies of a traveling web of material being fed into a bonding roll in the manufacturing of an absorbent article, distance "c" is commonly set at approximately 3mm.

Distance "d" is the actual width of cuff end bond 160. While the widths of elastics 142, 144, 152, 154 are comparatively insubstantial, the width of cuff end bond is substantial and

typically measures at 2mm. This distance “d” is an inherent property of this prior art dual cuff design.

Distance “e” is the length measured from cuff end bond 160 to second cuff elastic 152. To ensure that second cuff elastic 152 does not inadvertently get bonded by cuff end bond 160, and based on the tracking inaccuracies of a traveling web of material being fed into a bonding roll in the manufacturing of an absorbent article, distance “e” is commonly set at approximately 3mm.

Distance “f” is the length measured from second cuff elastic 152 to second cuff elastic 154. Both elastics 152, 154 are typically applied with adhesive to the traveling web of material. If elastics 152, 154 having adhesive (not shown) come in contact with one another, then they may inadvertently join, thus requiring the stopping and repairing of the manufacturing process. Given the dramatic impact of shutting down the manufacturing process, distance “f” is safely set at 5mm. Said distance may also be important for the proper functioning of said second cuff generally.

Distance “g” is the length measured from second cuff elastic 154 to cuff intermediate bond 170. More specifically, cuff intermediate bond 170 is intended to join dual cuff 130 to the topsheet (see FIG. 2). To ensure that second cuff elastic 154 does not inadvertently get bonded by cuff intermediate bond 170, and based on the tracking inaccuracies of a traveling web of material being fed into a bonding roll in the manufacturing of an absorbent article, distance “g” is commonly set at approximately 3mm.

Consequently, the summation of said widths for dual cuff 130 is equal to 25mm. Next, recognizing that there are two dual cuffs 130 per absorbent article (i.e., one on each side), the two dual cuffs 130 account for 50mm of the overall width of said article. Lastly, assume a common distance between said dual cuffs of 115mm. Thus, the overall width of the prior art absorbent article within the crotch region is equal to 165mm.

Referring now to FIG. 4a, a top view taken within encircled portion 3 of FIG. 1 is shown illustrating a dual cuff 30 within the crotch region in accordance with the present invention. FIG. 4b depicts a corresponding cross-sectional view of FIG. 4a. Dual cuff 30 is constructed from a continuous cuff material 33 which is enclosed by cuff bond 70. Dual cuff 30 has a proximate end 35, distal end 39 and regions therebetween identified as first cuff 40 and second cuff 50. More specifically, first cuff 40 has at least one elastic (although two elastics 42, 44 are shown) and second cuff 50 also has at least one elastic (although two elastics 52, 54 are shown) that are enveloped within cuff material 33.

In comparing the overall width of the absorbent article in FIG. 4a (present invention) to FIG. 3a (prior art), a similar analysis is conducted. For example, referring to FIG. 4a, distance “a” is substantially the same length as that provided in FIG. 3a; however, the length is measured from

longitudinal edge 28 to cuff distal edge 39 (as compared to 139a). Because the same safety and manufacturing considerations exist, distance "a" is commonly set at approximately 7mm.

Distance "b" (measured in FIG. 3a as the length measured from cuff distal edge 139a to cuff distal edge 139b) does not exist in FIG. 4a because a continuous cuff material 33 is folded to create cuff distal edge 39, rather than two cuff materials juxtaposed and bonded. Therefore, distance "b" is negligible.

Distance "c" (measured in FIG. 3a as the length measured from cuff distal edge 139b to cuff end bond 160) does not exist in FIG. 4a because the folded, continuous cuff material 33 does not need to be bonded in such close proximity to cuff distal edge 139. Therefore, distance "c" is negligible.

Distance "d" (measured in FIG. 3a as the actual width of cuff end bond 160) does not exist in FIG. 4a because no such bond in such close proximity to cuff distal edge 39 is needed. Therefore, distance "d" is negligible.

Distance "e" is substantially the same measurement as that provided in FIG. 3a; however, the length is measured from cuff distal edge 39 (as compared to cuff end bond 160) to second cuff elastic 52. Since cuff distal edge 39 is folded about second cuff elastic 52, distance "e" is negligible.

Distance "f" is substantially the same length (i.e., measured from second cuff elastic 52 to second cuff elastic 54) as that provided in FIG. 3a. Therefore, distance "f" is similarly set at 5mm.

Distance "g" is substantially the same length (i.e., measured from second cuff elastic 54 to cuff bond 70) as that provided in FIG. 3a. Therefore, distance "g" is similarly set at 3mm.

Consequently, the summation of said widths for dual cuff 30 is equal to 15mm. Next, recognizing that there are two dual cuffs 30 per absorbent article (i.e., one on each side), the two dual cuffs 30 account for 30mm of the overall width of said article. Lastly, assume a common distance between said dual cuffs of 115mm. Thus, the overall width of the prior art absorbent article within the crotch region is equal to 145mm.

In comparing the overall width of the FIG. 3a (prior art; measuring at 165mm) and FIG. 4a (present invention; measuring at 145mm), the difference is 20mm. This reduction in overall width within the crotch region has been discovered to provide significant comfort and wear properties. For example, toddlers wearing diapers in accordance with the present invention walk more naturally because the crotch region is narrower and thus said diaper does not significantly interfere with the inner legs of the wearer. Furthermore, caregivers, and sometimes the toddlers themselves, prefer the diaper to have a narrower crotch because it aesthetically looks more like

underwear. This latter product benefit is especially important as toddlers learn about the differences between diapers and underwear (i.e., potty-training).

FIG. 5 is a fragmentary sectional view taken along section line 5-5 of FIG. 1 and depicts the diaper construction in the first waist region 36 of the diaper 20 as it is shaped before being applied to the wearer (i.e., the diaper is subjected to elastic contraction). First cuff 40 is laid down (e.g., folded to create cuff fold 82) and joined to topsheet 24 so as to more readily conform to the wearer's waist region. First cuff 40 may be joined to topsheet 24 by a cuff tuckdown bond 80 which may be adhesive, ultrasonic bonding, compression bonding, thermal bonding, combinations thereof, and any other suitable bonding means known in the art which is appropriate for the specific materials employed.

Additionally, side panels 90 may be provided in first and second waist regions 36, 38 and adjacent to longitudinal edges 14. Side panels 90 may comprise a side panel elastic 92 and a side panel cover 94, wherein, the side panel elastic 92 is positioned between said side panel cover 94 and backsheet 26. Adhesive 23, or any other suitable material or method, may be used to join these components together and to cuff distal end 39.

FIG. 6 is a fragmentary sectional view taken along section line 2-2 of FIG. 1 and depicts another non-limiting, exemplary embodiment of a diaper construction in the crotch region 37 of a diaper as it is shaped before being applied to the wearer (i.e., the diaper is subjected to elastic contraction). Dual cuff 130 has a first cuff 140 and second cuff 150 that are joined together by adhesive 178 or any other suitable material/bonding technique. In this way, dual cuff 130 stands taller and thus may provide better exudate containment. While only a single location of adhesive 178 is shown, one skilled in the art would appreciate that multiple locations and configurations of adhesive application may be used.

FIG. 7 is a fragmentary sectional view taken along section line 2-2 of FIG. 1 and depicts another non-limiting, exemplary embodiment of a diaper construction in the crotch region 37 of a diaper as it is shaped before being applied to the wearer (i.e., the diaper is subjected to elastic contraction). Second cuff 150 may be constructed to stand substantially upright without the aid of additional elements (e.g., adhesive 178). For example, elastic 52 and/or elastic 54 may be constructed of a material having a larger diameter than that of elastics 42, 44. In another example, elastics 52 and/or elastic 54 may be applied having greater tension. In yet another example, elastic 52 may be continuously bonded and elastic 54 may be bonded near its ends to create a drawstring. One skilled in the art would also appreciate that such techniques may be applied to first cuff 140 and its respective elastics 42, 44.

FIG. 8 and FIG. 9 are fragmentary sectional views taken along section line 2-2 of FIG. 1 and depict exemplary embodiments of a diaper construction in the crotch region 37 of a diaper as

it is shaped before being applied to the wearer (i.e., the diaper is subjected to elastic contraction). More specifically, FIG. 8 shows an exemplary embodiment wherein first cuff 140 stands taller than second cuff 150. Conversely, FIG. 9 shows an exemplary embodiment wherein second cuff 150 stands taller than first cuff 140.

FIG. 10a is a close-up view taken within encircled portion 10 of FIG. 2 illustrating a fold-over technique of cuff material, wherein a lower cuff material end 33a is positioned longitudinally outboard of cuff bond. Alternatively, FIG. 10b is a close-up view taken within encircled portion 10 of FIG. 2 illustrating a fold-over technique of cuff material, wherein a lower cuff material end 33a is positioned longitudinally inboard of cuff bond. While both fold-over techniques are suitable for the present invention, the technique of FIG. 10a is preferable in that the cuff material may be cut on-line; whereas, the technique of FIG. 10b requires the cuff material to be pre-cut and then subsequently handled.

Embodiments of the present invention may also include pockets for receiving and containing waste, spacers which provide voids for waste, barriers for limiting the movement of waste in the article, compartments or voids which accept and contain waste materials deposited in the diaper 20, and the like, or any combinations thereof. Examples of pockets and spacers for use in absorbent products are described in U.S. Patent 5,514,121 issued to Roe et al. on May 7, 1996, entitled "Diaper Having Expulsive Spacer"; U.S. Patent 5,171,236 issued to Dreier et al. on December 15, 1992 entitled "Disposable Absorbent Article Having Core Spacers"; U.S. Patent 5,397,318 issued to Dreier on March 14, 1995 entitled "Absorbent Article Having A Pocket Cuff"; U.S. Patent 5,540,671 issued to Dreier on July 30, 1996 entitled "Absorbent Article Having A Pocket Cuff With An Apex"; PCT Application WO 93/25172 published December 3, 1993 entitled "Spacers For Use In Hygienic Absorbent Articles And Disposable Absorbent Articles Having Such Spacer"; U.S. Patent 5,306,266 entitled "Flexible Spacers For Use In Disposable Absorbent Articles" issued to Freeland on April 26, 1994; and U.S. Patent 5,997,520 entitled "Disposable Absorbent Article With Selectively Expandable or Inflatable Component" issued to Ahr et al. on December 7, 1999. Examples of compartments or voids are disclosed in U.S. Patent 4,968,312 entitled "Disposable Fecal Compartmenting Diaper" issued to Khan on November 6, 1990; U.S. Patent 4,990,147 entitled "Absorbent Article With Elastic Liner For Waste Material Isolation" issued to Freeland on February 5, 1991; U.S. Patent 5,062,840, entitled "Disposable Diapers" issued to Holt et al on November 5, 1991; and U.S. Patent 5,269,755 entitled "Trisection Topsheets For Disposable Absorbent Articles And Disposable Absorbent Articles Having Such Trisection Topsheets" issued to Freeland et al on December 14, 1993. Examples of suitable transverse barriers are described in U.S. Pat. No. 5,554,142 entitled "Absorbent Article Having Multiple Effective Height Transverse Partition" issued September 10, 1996 in the name of Dreier

et al.; PCT Patent WO 94/14395 entitled "Absorbent Article Having An Upstanding Transverse Partition" published July 7, 1994 in the name of Freeland, et al.; and U.S. Patent No. 5,653,703 Absorbent Article Having Angular Upstanding Transverse Partition issued Aug. 5, 1997 to Roe, et al. Examples of other structures especially suitable for management of low viscosity feces are disclosed in U.S. Patents 5,941,864 issued to Roe et al. on August 24, 1999; U.S. Patent No. 5,977,430 issued to Roe et al. on Nov. 2, 1999 and 6,013,063 issued to Roe et al. on January 11, 2000. All of the above-cited references are hereby incorporated by reference herein.

In addition, the present invention may be suitable for other diaper embodiments including those disclosed in U.S. Patent No. 6,010,491 titled "Viscous Fluid Bodily Waste Management Article" issued January 4, 2000; U.S. Patent No. 5,873,870 titled "Fit And Sustained Fit Of A Diaper Via Chassis And Core Modifications" issued February 23, 1999; U.S. Patent No. 5,897,545 titled "Elastomeric Side Panel for Use with Convertible Absorbent Articles" issued April 27, 1999; U.S. Patent No. 5,904,673 titled "Absorbent Article With Structural Elastic-Like Film Web Waist Belt" issued May 18, 1999; U.S. Patent No. 5,931,827 titled "Disposable Pull On Pant" issued August 3, 1999; U.S. Patent No. 5,977,430 titled "Absorbent Article With Macro-Particulate Storage Structure" issued November 2, 1999 and U.S. Patent No. 6,004,306 titled "Absorbent Article With Multi-Directional Extensible Side Panels" issued December 21, 1999, the disclosures of which are incorporated herein by reference.

All documents cited are, in relevant part, incorporated herein by reference; the citation of any document is not to be construed as an admission that it is prior art with respect to the present invention.

While particular embodiments of the present invention have been illustrated and described, it would be obvious to those skilled in the art that various other changes and modifications can be made without departing from the spirit and scope of the invention. It is therefore intended to cover in the appended claims all such changes and modifications that are within the scope of this invention.

What is claimed is:

1. A unitary disposable absorbent article characterized by comprising:  
an absorbent core having a garment surface and a body surface;  
a liquid permeable topsheet positioned adjacent said body surface of said absorbent core;  
a liquid impermeable backsheet positioned adjacent said garment surface of said absorbent core;  
and  
an elastically contractible dual cuff having a proximate end and a distal end, said dual cuff being joined to said article by a cuff bond, said dual cuff having a first cuff and a second cuff, said first cuff being disposed between said proximate end and said cuff bond, said second cuff being disposed between said cuff bond and said distal end, said dual cuff being constructed of a continuous cuff material and enclosed by said cuff bond,  
wherein said distal end is formed by said cuff material being folded, wherein said proximate end is formed by said cuff material being folded;  
wherein said first cuff envelopes at least one first elastic, wherein said first elastic has a first and second end, wherein said first elastic is secured to said first cuff near said first and second ends;  
wherein said second cuff envelopes at least one second elastic, wherein said second elastic has a first and second end, wherein said second elastic is secured to said second cuff near said first and second ends;  
wherein said first and second cuffs are barrier cuffs.
2. The absorbent article of claim 1 wherein said first cuff envelopes at least one elastic.
3. The absorbent article of claim 2 wherein said elastic is operatively associated with said first cuff by securing it with an elastic attachment element.
4. The absorbent article of claim 1 wherein said second cuff envelopes at least one elastic.
5. The absorbent article of claim 4 wherein said elastic is operatively associated with said second cuff by securing it with an elastic attachment element.
6. The absorbent article of claim 1 wherein said article is a disposable diaper.
7. The absorbent article of claim 6 wherein said disposable diaper is a prefastened diaper.

8. The absorbent article of claim 1 wherein said continuous cuff material is constructed of a lesser-water-permeable material with a more-water-permeable material placed inside said lesser-water-permeable material.
9. The absorbent article of claim 1 wherein said dual cuff is bonded to said article by a single bond.
10. The absorbent article of claim 9 wherein said single bond is said cuff bond.

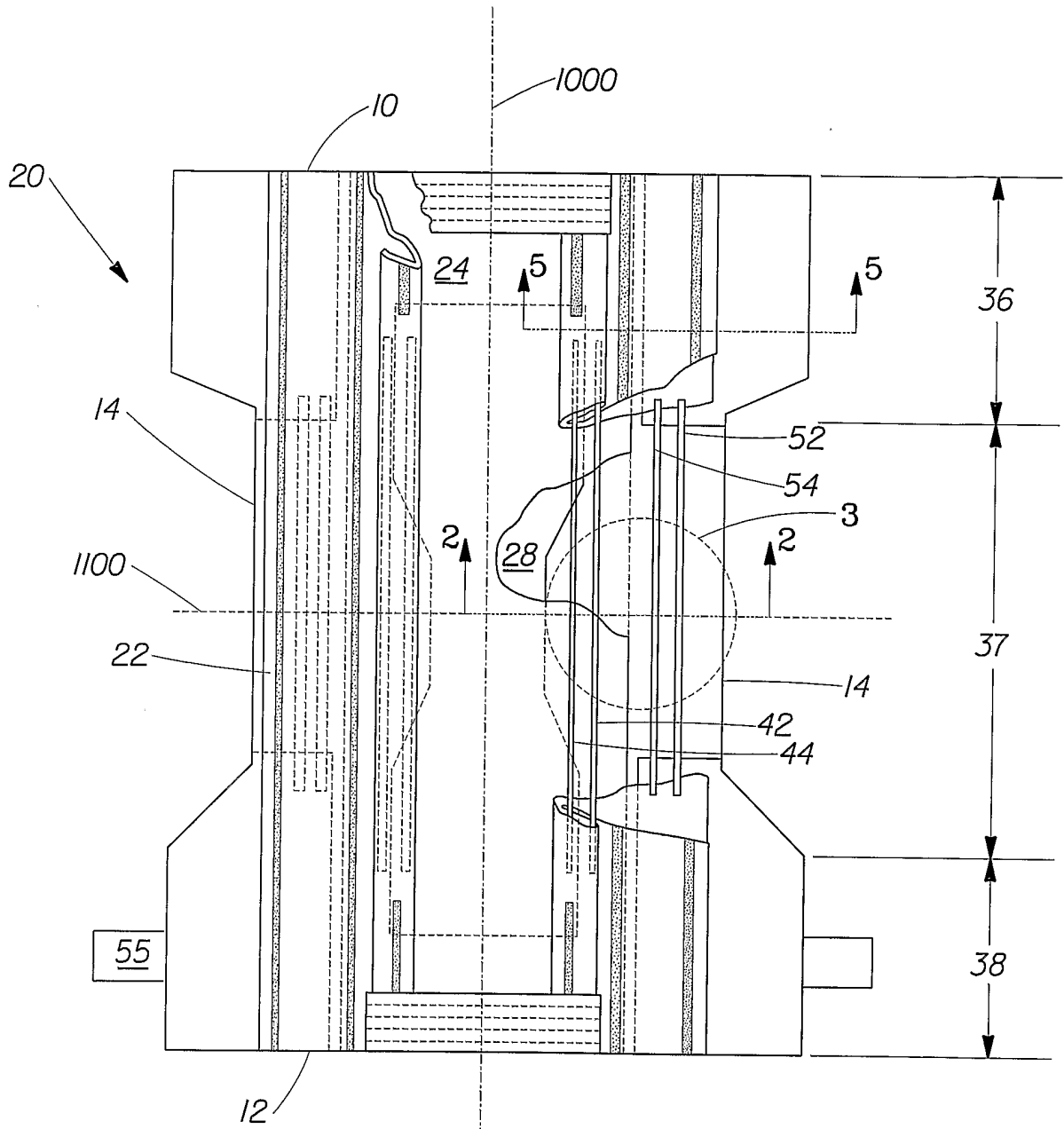

Fig. 1

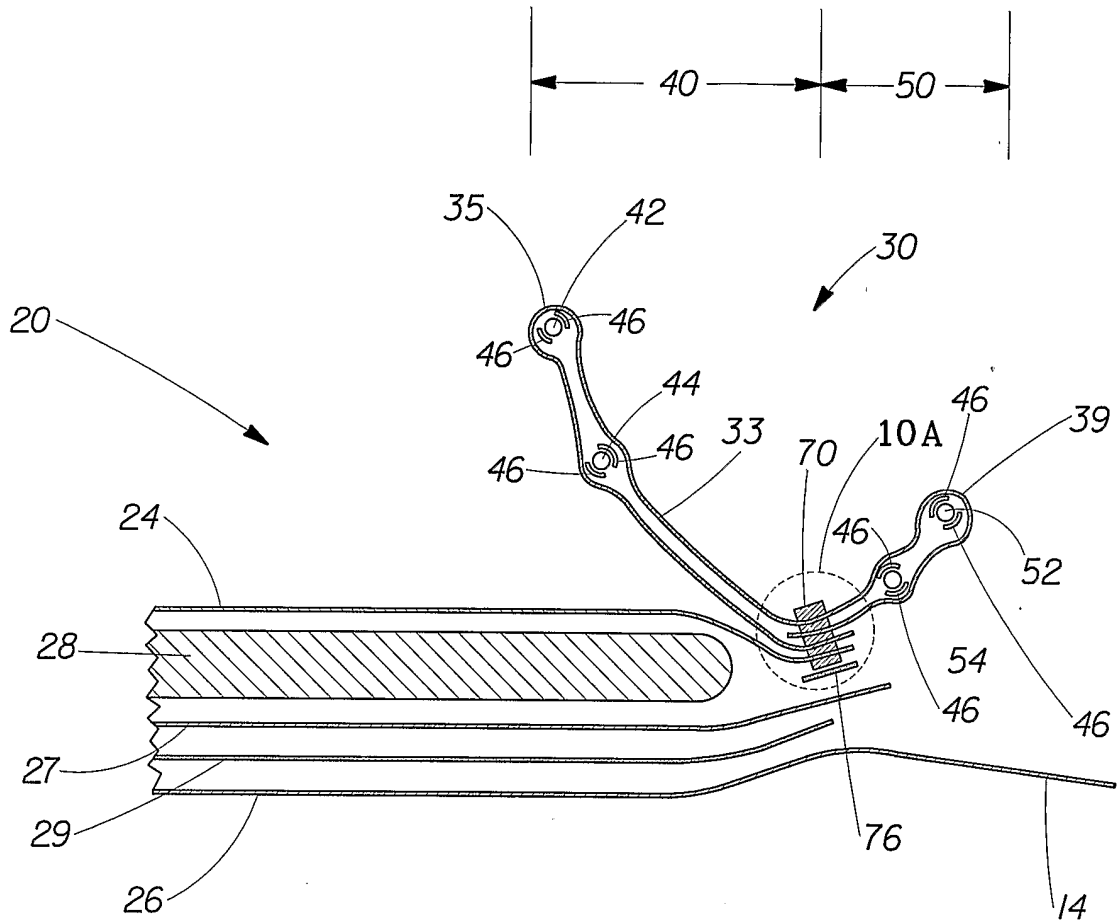

Fig. 2



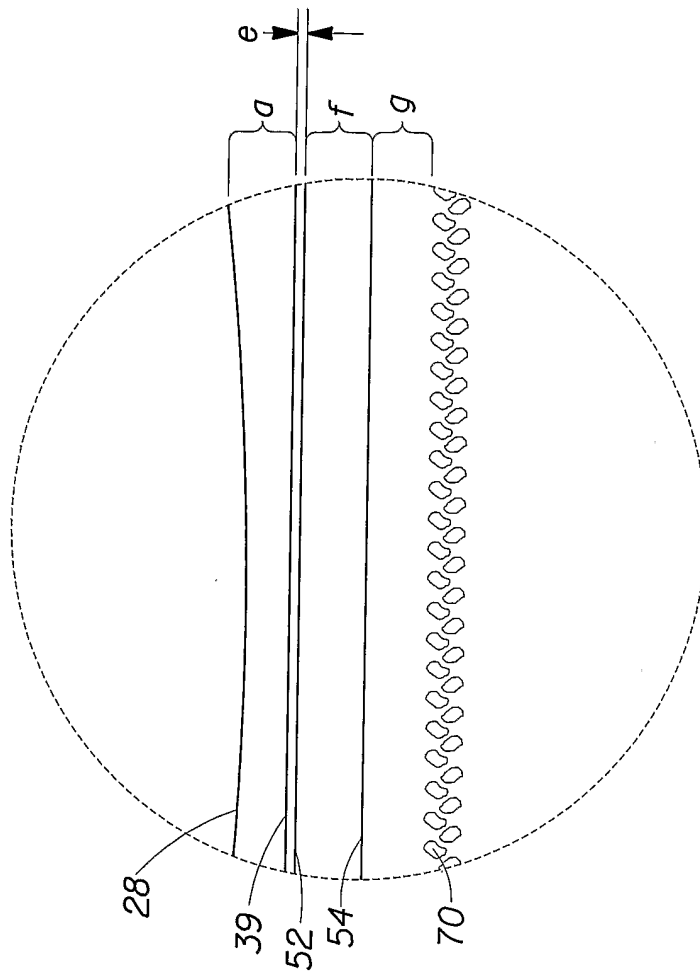

Fig. 4A

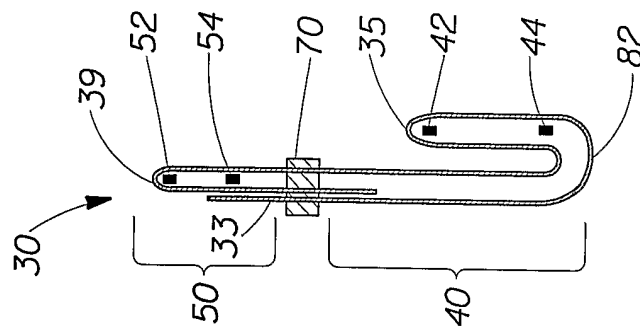

Fig. 4B

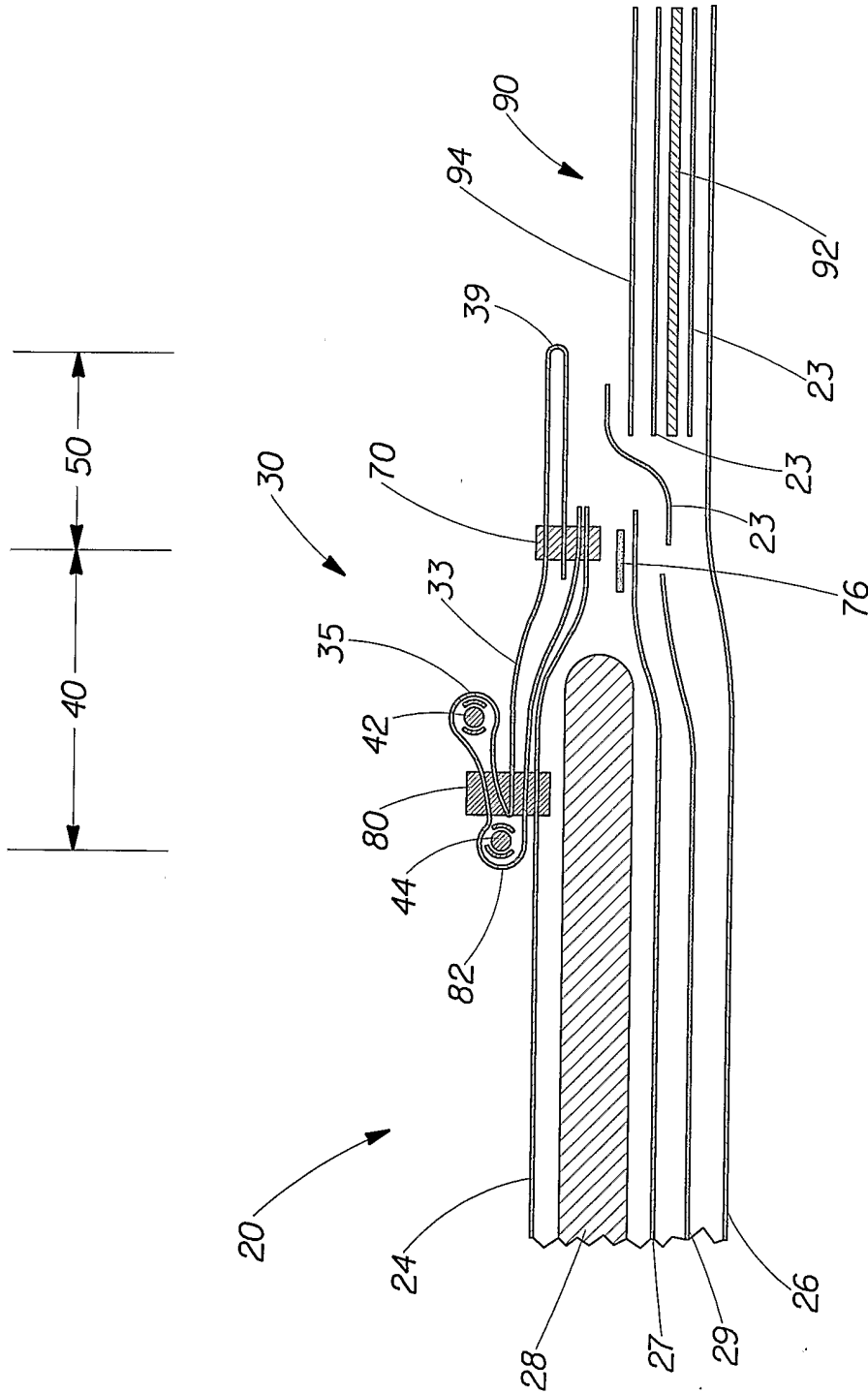

Fig. 5

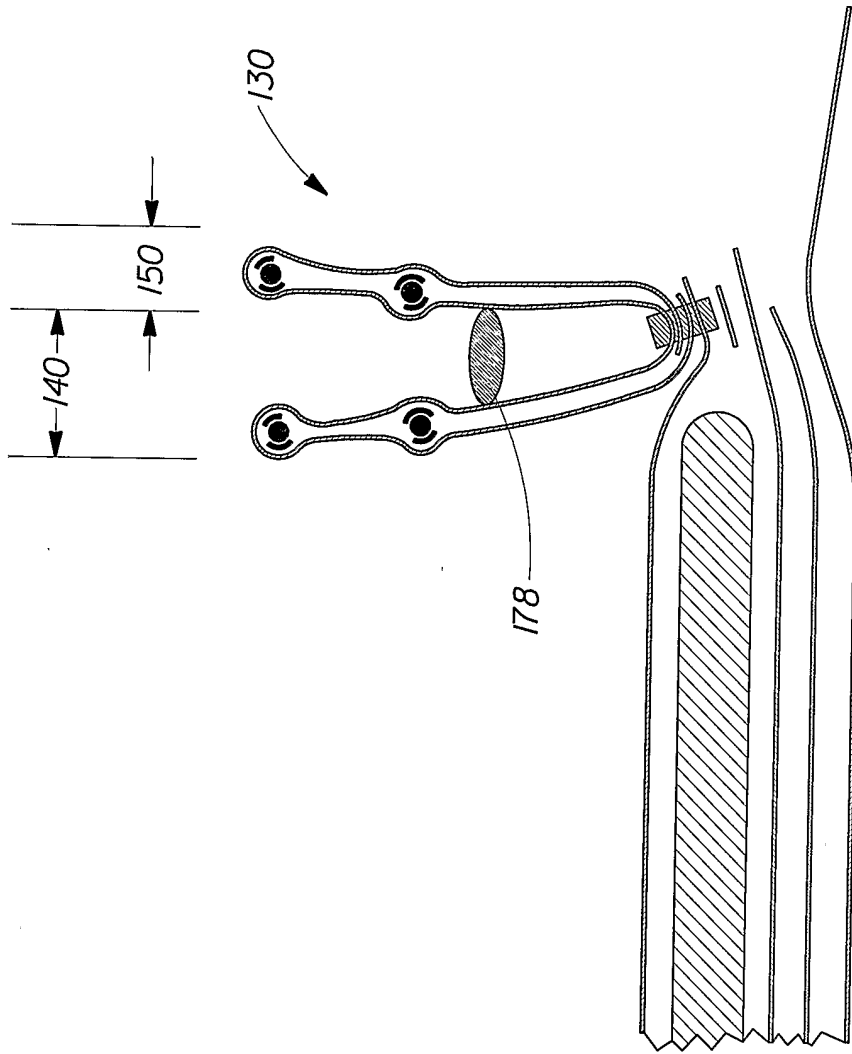

Fig. 6

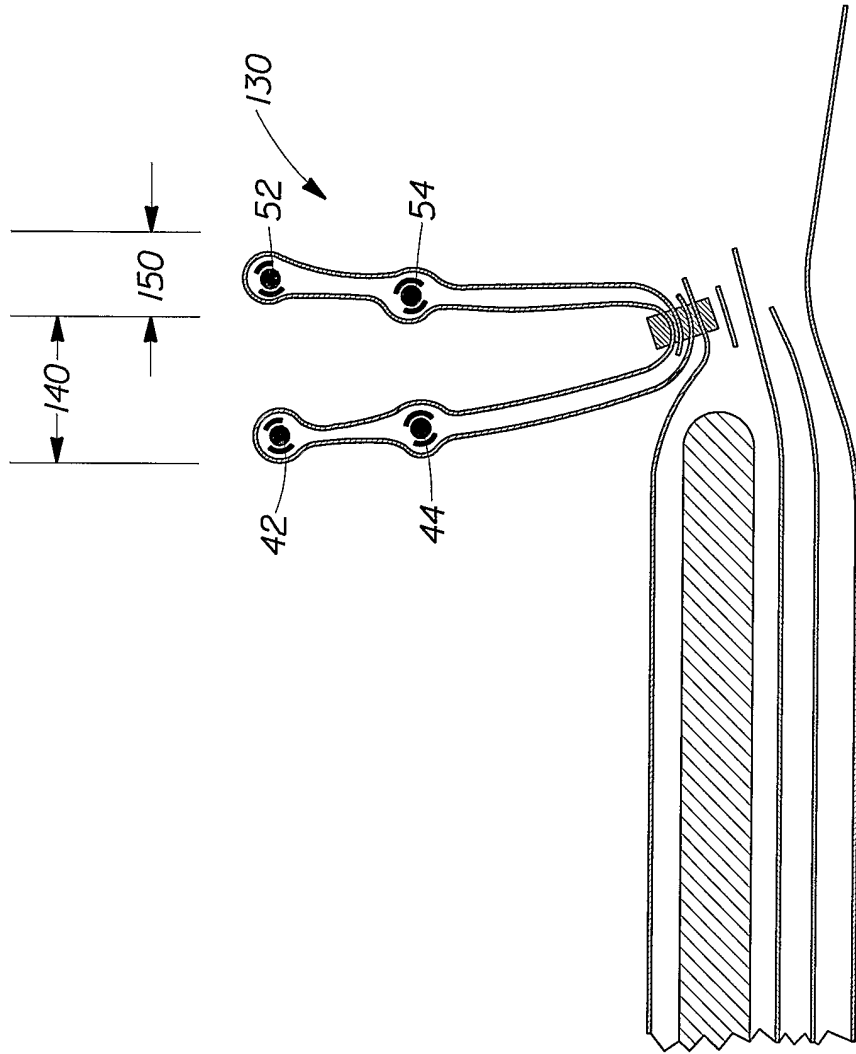

Fig. 7

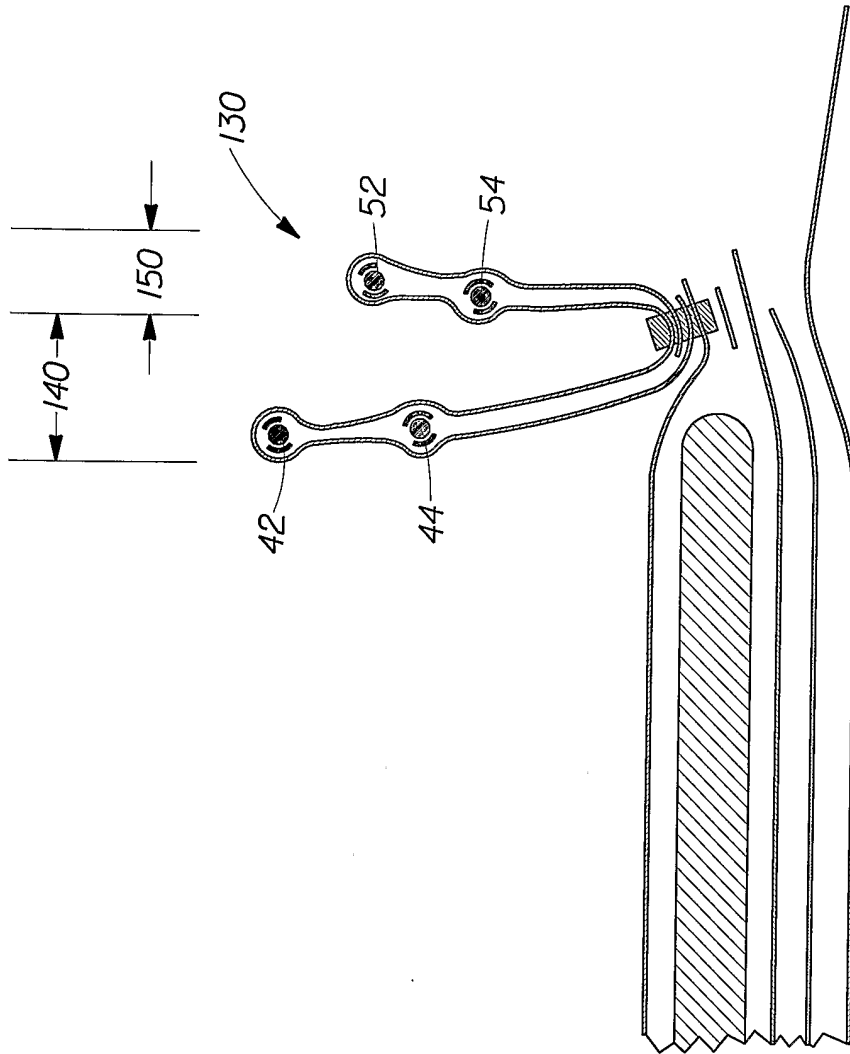

Fig. 8

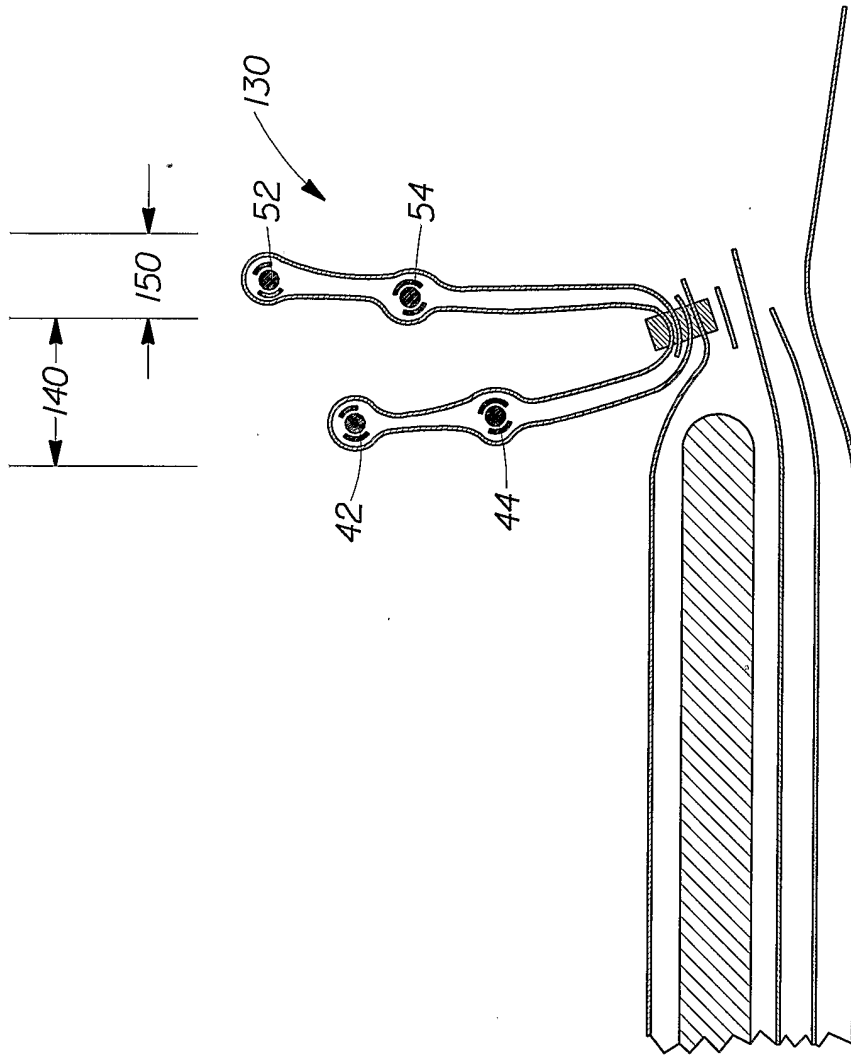

Fig. 9

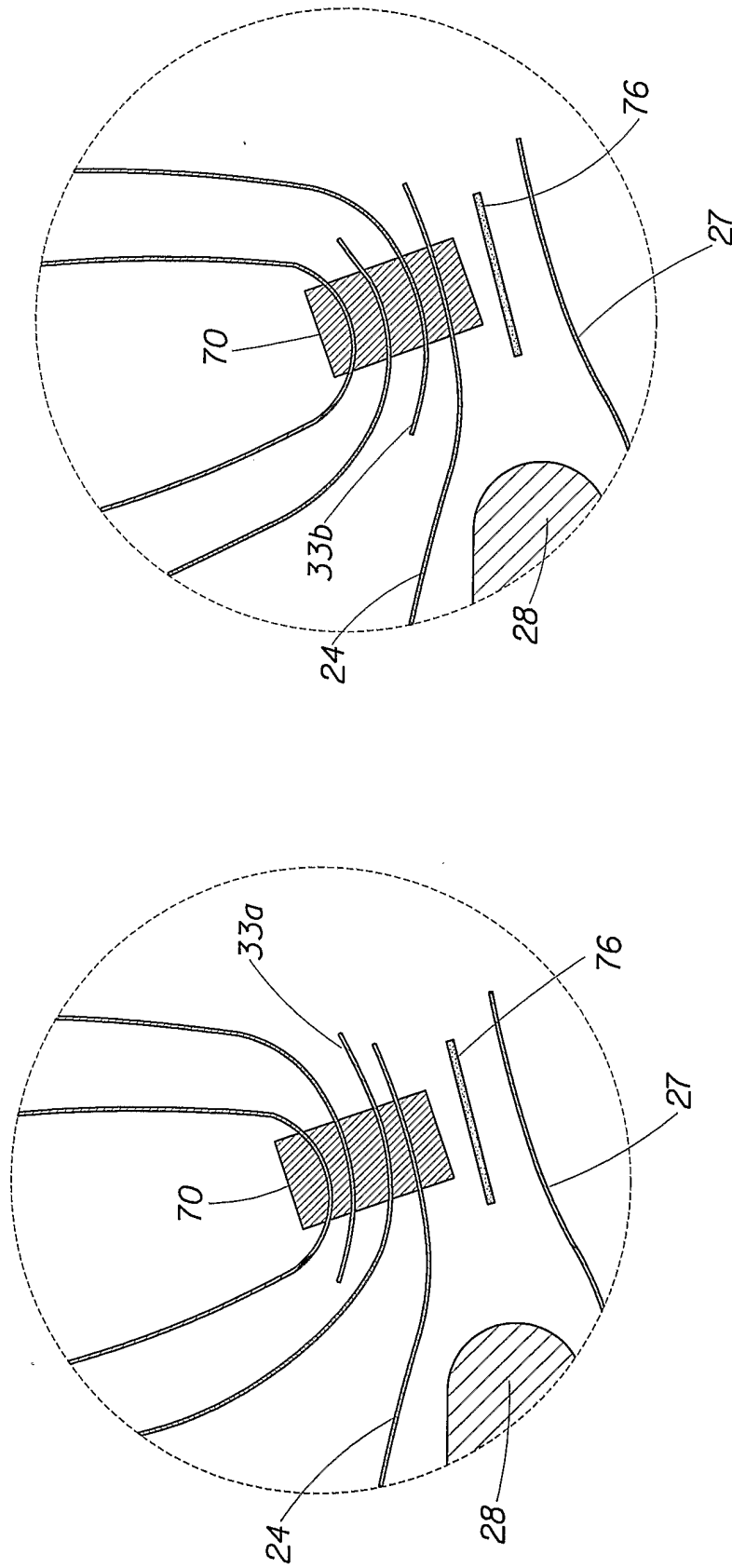

Fig. 10A

Fig. 10B

# INTERNATIONAL SEARCH REPORT

Inter	Application No
	PCT/US2005/012536

**A. CLASSIFICATION OF SUBJECT MATTER**  
 IPC 7 A61F13/15

According to International Patent Classification (IPC) or to both national classification and IPC

**B. FIELDS SEARCHED**

Minimum documentation searched (classification system followed by classification symbols)  
 IPC 7 A61F

Documentation searched other than minimum documentation to the extent that such documents are included in the fields searched

Electronic data base consulted during the international search (name of data base and, where practical, search terms used)

EPO-Internal, WPI Data, PAJ

**C. DOCUMENTS CONSIDERED TO BE RELEVANT**

Category °	Citation of document, with indication, where appropriate, of the relevant passages	Relevant to claim No.
X	WO 00/07534 A (KIMBERLY-CLARK WORLDWIDE, INC) 17 February 2000 (2000-02-17) page 2, line 6 - page 3, line 7 page 7, line 9 - page 12, line 26 page 17, line 6 - line 27 page 27, line 29 - page 38, line 3 page 48, line 16 - page 52, line 2 page 78, line 25 - page 80, line 19; figures 1,4-8	1-10
X	----- WO 99/20215 A (KIMBERLY-CLARK WORLDWIDE, INC) 29 April 1999 (1999-04-29) the whole document ----- -/--	1-10

Further documents are listed in the continuation of box C.

Patent family members are listed in annex.

° Special categories of cited documents :

- \*A\* document defining the general state of the art which is not considered to be of particular relevance
- \*E\* earlier document but published on or after the international filing date
- \*L\* document which may throw doubts on priority claim(s) or which is cited to establish the publication date of another citation or other special reason (as specified)
- \*O\* document referring to an oral disclosure, use, exhibition or other means
- \*P\* document published prior to the international filing date but later than the priority date claimed

- \*T\* later document published after the international filing date or priority date and not in conflict with the application but cited to understand the principle or theory underlying the invention
- \*X\* document of particular relevance; the claimed invention cannot be considered novel or cannot be considered to involve an inventive step when the document is taken alone
- \*Y\* document of particular relevance; the claimed invention cannot be considered to involve an inventive step when the document is combined with one or more other such documents, such combination being obvious to a person skilled in the art.
- \*&\* document member of the same patent family

Date of the actual completion of the international search

22 July 2005

Date of mailing of the international search report

01/08/2005

Name and mailing address of the ISA  
 European Patent Office, P.B. 5818 Patentlaan 2  
 NL - 2280 HV Rijswijk  
 Tel. (+31-70) 340-2040, Tx. 31 651 epo nl,  
 Fax: (+31-70) 340-3016

Authorized officer  
  
 Demay, S

# INTERNATIONAL SEARCH REPORT

Inter	Application No
	PCT/US2005/012536

C.(Continuation) DOCUMENTS CONSIDERED TO BE RELEVANT		
Category *	Citation of document, with indication, where appropriate, of the relevant passages	Relevant to claim No.
X	WO 96/05792 A (THE PROCTER & GAMBLE COMPANY; YAMADA, JIRO; FUKUDA, EIRO) 29 February 1996 (1996-02-29) page 2, paragraph 4 - page 3, paragraph 2 page 4, paragraph 2 - page 6, paragraph 2 page 8, paragraph 1 - page 12, paragraph 3; figures 1-3 -----	1-10
X	WO 94/18927 A (THE PROCTER & GAMBLE COMPANY; YAMADA, JIRO; HIUKE, TAKASHI; SHIKATA, H) 1 September 1994 (1994-09-01) page 4, paragraph 1 - page 5, paragraph 1 page 7, paragraph 1 page 8, paragraph 3 - paragraph 4 page 11, paragraph 1 - page 15, paragraph 3 page 18, paragraph 1 - paragraph 2; figures 1-3 -----	1-10
A	WO 97/20532 A (KIMBERLY-CLARK WORLDWIDE, INC) 12 June 1997 (1997-06-12) figures 10,12 -----	1-10
A	US 4 795 454 A (DRAGOO ET AL) 3 January 1989 (1989-01-03) cited in the application the whole document -----	1-10

## INTERNATIONAL SEARCH REPORT

Inter Application No  
PCT/US2005/012536

Patent document cited in search report		Publication date	Patent family member(s)	Publication date			
WO 0007534	A	17-02-2000	US 6248097 B1	19-06-2001			
			AU 743281 B2	24-01-2002			
			AU 5338299 A	28-02-2000			
			BR 9912640 A	26-06-2001			
			CN 1311651 A	05-09-2001			
			EP 1102571 A1	30-05-2001			
			JP 2002522117 T	23-07-2002			
			RU 2233148 C2	27-07-2004			
			TW 569770 Y	01-01-2004			
			WO 0007534 A1	17-02-2000			
			US 2001025683 A1	04-10-2001			
			US 6235137 B1	22-05-2001			
			ZA 200007450 A	14-06-2001			
			WO 9920215	A	29-04-1999	US 5993433 A	30-11-1999
AU 736116 B2	26-07-2001						
AU 1098199 A	10-05-1999						
BR 9815226 A	02-10-2001						
CA 2304672 A1	29-04-1999						
CN 1282234 A	31-01-2001						
EG 21933 A	30-04-2002						
EP 1024772 A1	09-08-2000						
HU 0004915 A2	28-04-2001						
JP 2001520082 T	30-10-2001						
NZ 503695 A	01-03-2002						
PL 340219 A1	15-01-2001						
RU 2203010 C2	27-04-2003						
SK 5672000 A3	18-01-2001						
TR 200001065 T2	21-08-2000						
TW 541947 Y	11-07-2003						
WO 9920215 A1	29-04-1999						
ZA 9809276 A	25-05-1999						
WO 9605792	A	29-02-1996	JP 8066424 A	12-03-1996			
			AU 3365295 A	14-03-1996			
			BR 9508759 A	13-01-1998			
			CA 2197181 A1	29-02-1996			
			CN 1158079 A	27-08-1997			
			EP 0955977 A1	17-11-1999			
			KR 203652 B1	15-06-1999			
			WO 9605792 A1	29-02-1996			
			US 5911713 A	15-06-1999			
			ZA 9507042 A	29-03-1996			
			WO 9418927	A	01-09-1994	JP 6254119 A	13-09-1994
AU 6269094 A	14-09-1994						
CA 2156482 A1	01-09-1994						
CZ 9502148 A3	17-01-1996						
EP 0801550 A1	22-10-1997						
FI 953951 A	12-09-1995						
HU 71928 A2	28-02-1996						
JP 8508657 T	17-09-1996						
NO 953334 A	24-08-1995						
SG 54155 A1	16-11-1998						
WO 9418927 A1	01-09-1994						
WO 9720532	A	12-06-1997				AU 705076 B2	13-05-1999
						AU 1057997 A	27-06-1997

## INTERNATIONAL SEARCH REPORT

 Inter Application No  
 PCT/US2005/012536

Patent document cited in search report	Publication date	Patent family member(s)	Publication date	
WO 9720532	A	BR 9612575	A 27-07-1999	
		CN 1203521	A 30-12-1998	
		CZ 9801707	A3 13-01-1999	
		DE 69620012	D1 25-04-2002	
		DE 69620012	T2 21-11-2002	
		EG 21888	A 30-04-2002	
		EP 0866682	A1 30-09-1998	
		ES 2174121	T3 01-11-2002	
		HU 9902158	A2 28-10-1999	
		IL 124339	A 21-04-2002	
		JP 2000500987	T 02-02-2000	
		NZ 323595	A 29-03-1999	
		PL 327039	A1 09-11-1998	
		RU 2179008	C2 10-02-2002	
		SK 72798	A3 11-01-1999	
		TR 9801013	T2 21-09-1998	
		WO 9720532	A1 12-06-1997	
		ZA 9609373	A 02-06-1997	
		CA 2166008	A1 19-06-1997	
		ID 16750	A 06-11-1997	
US 5904675	A 18-05-1999			
<hr/>				
US 4795454	A	03-01-1989	AR 243764	A1 30-09-1993
			AT 70170	T 15-12-1991
			AU 614065	B2 22-08-1991
			AU 7950287	A 14-04-1988
			BR 8705461	A 24-05-1988
			CA 1290501	C 15-10-1991
			DE 3775161	D1 23-01-1992
			DK 530387	A 11-04-1988
			EG 18495	A 30-04-1993
			EP 0263720	A1 13-04-1988
			ES 2026916	T3 16-05-1992
			FI 874457	A ,B, 11-04-1988
			GR 3003326	T3 17-02-1993
			HK 47194	A 20-05-1994
			IE 60672	B1 10-08-1994
			JP 2561675	B2 11-12-1996
			JP 63182401	A 27-07-1988
			KR 9609236	B1 16-07-1996
			MA 21077	A1 01-07-1988
			MX 174128	B 22-04-1994
NZ 222115	A 26-02-1991			
PH 24439	A 25-06-1990			
PT 85890	A ,B 01-11-1987			
TR 23472	A 22-01-1990			