



- (51) International Patent Classification: *A61F 2/24* (2006.01)
 - (21) International Application Number: PCT/US2015/016927
 - (22) International Filing Date: 20 February 2015 (20.02.2015)
 - (25) Filing Language: English
 - (26) Publication Language: English
 - (30) Priority Data:

61/943,270	21 February 2014 (21.02.2014)	US
61/950,748	10 March 2014 (10.03.2014)	US
62/004,637	29 May 2014 (29.05.2014)	US
 - (71) Applicant: **CARDIAQ VALVE TECHNOLOGIES, INC.** [US/US]; 2 Jenner, Suite 100, Irvine, CA 92618 (US).
 - (72) Inventors: **RABITO, Glen**; 2 Jenner, Suite 100, Irvine, CA 92618 (US). **RATZ, J., Brent**; 2 Jenner, Suite 100, Irvine, CA 92618 (US). **PESCE, Luca**; 2 Jenner, Suite 100, Irvine, CA 92618 (US). **QUADRI, Arshad**; 2 Jenner, Suite 100, Irvine, CA 92618 (US). **LAM, Lindsay**; 2 Jenner, Suite 100, Irvine, CA 92618 (US). **LIAO, Yen**; 2 Jenner, Suite 100, Irvine, CA 92618 (US). **SANCHEZ, Julio, Cesar**; 2 Jenner, Suite 100, Irvine, CA 92618 (US). **LONDON, David**; 2 Jenner, Suite 100, Irvine, CA 92618 (US). **JOHNSON, Garrett**; 2 Jenner, Suite 100, Irvine, CA 92618 (US). **COOPER, Alexander**; 2 Jenner, Suite 100, Irvine, CA 92618 (US).
 - (74) Agent: **CHRISTENSEN, Michael, R.**; Knobbe Martens Olson & Bear, LLP, 2040 Main Street, 14th Floor, Irvine, CA 92614 (US).
 - (81) Designated States (unless otherwise indicated, for every kind of national protection available): AE, AG, AL, AM, AO, AT, AU, AZ, BA, BB, BG, BH, BN, BR, BW, BY, BZ, CA, CH, CL, CN, CO, CR, CU, CZ, DE, DK, DM, DO, DZ, EC, EE, EG, ES, FI, GB, GD, GE, GH, GM, GT, HN, HR, HU, ID, IL, IN, IR, IS, JP, KE, KG, KN, KP, KR, KZ, LA, LC, LK, LR, LS, LU, LY, MA, MD, ME, MG, MK, MN, MW, MX, MY, MZ, NA, NG, NI, NO, NZ, OM, PA, PE, PG, PH, PL, PT, QA, RO, RS, RU, RW, SA, SC, SD, SE, SG, SK, SL, SM, ST, SV, SY, TH, TJ, TM, TN, TR, TT, TZ, UA, UG, US, UZ, VC, VN, ZA, ZM, ZW.
 - (84) Designated States (unless otherwise indicated, for every kind of regional protection available): ARIPO (BW, GH, GM, KE, LR, LS, MW, MZ, NA, RW, SD, SL, ST, SZ, TZ, UG, ZM, ZW), Eurasian (AM, AZ, BY, KG, KZ, RU, TJ, TM), European (AL, AT, BE, BG, CH, CY, CZ, DE, DK, EE, ES, FI, FR, GB, GR, HR, HU, IE, IS, IT, LT, LU, LV, MC, MK, MT, NL, NO, PL, PT, RO, RS, SE, SI, SK, SM, TR), OAPI (BF, BJ, CF, CG, CI, CM, GA, GN, GQ, GW, KM, ML, MR, NE, SN, TD, TG).
- Published:**
- with international search report (Art. 21(3))
 - before the expiration of the time limit for amending the claims and to be republished in the event of receipt of amendments (Rule 48.2(h))



(54) Title: DELIVERY DEVICE FOR CONTROLLED DEPLOYMENT OF A REPLACEMENT VALVE

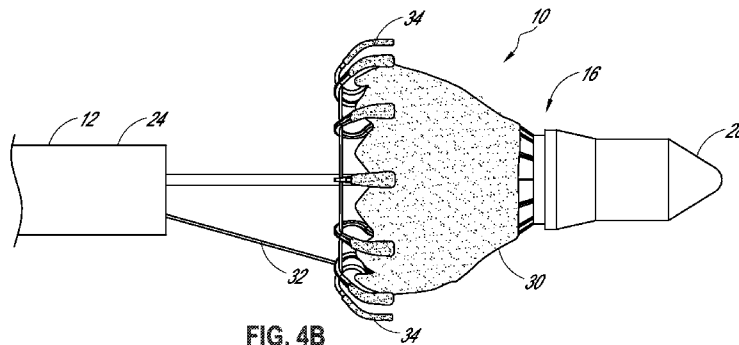

(57) Abstract: Are described herein delivery devices for delivering a prosthesis within a lumen or body cavity for implantation. A delivery system (10) can include a plurality of components which are moveable relative to each other. The delivery system can include a nose cone (28) which can cover at least a first end of the prosthesis (30), an outer elongate member (24) which can cover at least a second end of the prosthesis, and a tether (32) which can at least partially restrain the prosthesis from deployment.

DELIVERY DEVICE FOR CONTROLLED DEPLOYMENT OF A REPLACEMENT VALVE

CROSS-REFERENCE TO RELATED APPLICATIONS

[0001] This application claims priority to U.S. Provisional App. No. 61/943,270 filed February 21, 2014, titled PROSTHESIS DELIVERY DEVICE AND METHODS OF USE, U.S. Provisional App. No. 61/950,748 filed March 10, 2014, titled PROSTHESIS, DELIVERY DEVICE AND METHODS OF USE, and U.S. Provisional App. No. 62/004,637 filed May 29, 2014, titled PROSTHESIS, DELIVERY DEVICE AND METHODS OF USE, each of which is hereby incorporated herein by reference in its entirety and is to be considered a part of this specification.

BACKGROUND

Field

[0002] Certain embodiments disclosed herein relate generally to prostheses for implantation within a lumen or body cavity and delivery devices for a prosthesis. In particular, the prostheses and delivery devices relate in some embodiments to replacement heart valves, such as replacement mitral heart valves.

Background

[0003] Human heart valves, which include the aortic, pulmonary, mitral and tricuspid valves, function essentially as one-way valves operating in synchronization with the pumping heart. The valves allow blood to flow downstream, but block blood from flowing upstream. Diseased heart valves exhibit impairments such as narrowing of the valve or regurgitation, which inhibit the valves' ability to control blood flow. Such impairments reduce the heart's blood-pumping efficiency and can be a debilitating and life threatening condition. For example, valve insufficiency can lead to conditions such as heart hypertrophy and dilation of the ventricle. Thus, extensive efforts have been made to develop methods and apparatuses to repair or replace impaired heart valves.

[0004] Prostheses exist to correct problems associated with impaired heart valves. For example, mechanical and tissue-based heart valve prostheses can be used to replace

impaired native heart valves. More recently, substantial effort has been dedicated to developing replacement heart valves, particularly tissue-based replacement heart valves that can be delivered with less trauma to the patient than through open heart surgery. Replacement valves are being designed to be delivered through minimally invasive procedures and even percutaneous procedures. Such replacement valves often include a tissue-based valve body that is connected to an expandable frame that is then delivered to the native valve's annulus.

[0005] Development of prostheses including but not limited to replacement heart valves that can be compacted for delivery and then controllably expanded for controlled placement has proven to be particularly challenging. An additional challenge relates to the ability of such prostheses to be secured relative to intraluminal tissue, e.g., tissue within any body lumen or cavity, in an atraumatic manner.

[0006] Delivering a prosthesis to a desired location in the human body, for example delivering a replacement heart valve to the mitral valve, can also be challenging. Obtaining access to perform procedures in the heart or in other anatomical locations may require delivery of devices percutaneously through tortuous vasculature or through open or semi-open surgical procedures. The ability to control the deployment of the prosthesis at the desired location can also be challenging.

SUMMARY

[0007] Embodiments of the present disclosure are directed to a prosthesis, such as but not limited to a replacement heart valve. Further embodiments are directed to delivery systems, devices and/or methods of use to deliver and/or controllably deploy a prosthesis, such as but not limited to a replacement heart valve, to a desired location within the body. In some embodiments, a replacement heart valve and methods for delivering a replacement heart valve to a native heart valve, such as a mitral valve, are provided.

[0008] According to some embodiments, a delivery system can be used for controlled deployment of a prosthesis or replacement valve. In some embodiments, the delivery system can comprise a first member, a second member, and a tether. The first member can be configured to at least partially restrain a first end of the prosthesis or replacement valve. The second member can be configured to at least partially restrain a

second end of the prosthesis or replacement valve. The tether can be configured to at least partially encircle the prosthesis or replacement valve and radially restrain at least a portion of the prosthesis or replacement valve after the second member has been removed from the second end of the prosthesis or replacement valve. The tether can be configured to radially restrain at least a portion of the prosthesis or replacement valve while the first member still at least partially restrains the first end of the prosthesis or replacement valve.

[0009] According to some embodiments, the first member can comprise a first shaft and the second member can comprise a second shaft, the second shaft being positioned over the first shaft and slidable relative to the first shaft. The first member can comprise a nose cone configured to receive and cover the first end of the prosthesis or replacement valve. The nose cone can be connected to a distal end of the first shaft. The nose cone can comprise a proximally-facing opening to receive at least a first end of the prosthesis or replacement valve. The nose cone can comprise a taper towards the distal end of the nose cone. An outer diameter of the nose cone can be similar to an outer diameter of the second shaft. An outer diameter of the nose cone is similar to an inner diameter of the second shaft. The first member can comprise an inner retention ring configured to engage the first end of the prosthesis or replacement valve. The inner retention ring can be connected to a distal portion of an inner retention shaft. The inner retention shaft can be positioned between the first shaft and the second shaft and be slidable relative to the first shaft. The inner retention ring can comprise a taper towards a proximal end of the inner retention ring. The inner retention ring can comprise a cavity at or near a distal end of the inner retention ring. The inner retention ring can comprise a compressible member received at least partially within the cavity, the compressible member having a compressed diameter and an expanded diameter.

[0010] According to some embodiments, the delivery system can comprise a tether retention assembly configured to restrain the tether such that the tether can be tensioned to restrain at least a portion of the prosthesis or replacement valve. The tether retention assembly can comprise an inner component and an outer component. The outer component can be configured to cooperate with the inner component to restrain the tether. The inner component can comprise a C-lock. The outer component can comprise a sheath. The outer component can be moveable relative to the inner component to release the tether.

The tether retention assembly can further comprise a locking shaft. The outer component can be positioned at or near a distal end of the locking shaft. The locking shaft can comprise a radial protrusion which can be configured to maintain radial alignment between the locking shaft and the second shaft. The locking shaft can comprise a guide member for the tether.

[0011] According to some embodiments, the second member can comprise an outer elongate hollow member configured to cover at least the second end of the prosthesis or replacement valve. The outer elongate member can be connected to a distal end of the second shaft. The outer elongate hollow member can have a substantially constant diameter throughout the entirety of its length. The diameter of the outer elongate hollow member can be substantially similar to a diameter of the second shaft. The outer elongate hollow member can be moveable relative to the first member to uncover the second end of the prosthesis or replacement valve while the first end of the prosthesis or replacement valve remains engaged to the first member. The delivery system can comprise an introducer sheath positioned over the second shaft. The delivery system can comprise a plug, the plug being moveable to engage the first member when the first member is retrieved from a patient. The delivery system can comprise a plug shaft positioned between the first shaft and the second shaft and can be slidable relative to the first shaft. The first shaft can be hollow to receive a guidewire.

[0012] According to some embodiments, the delivery system can comprise a prosthesis or replacement valve, wherein a first end of the prosthesis or replacement valve engages the first member and a second end of the prosthesis or replacement valve engages the second member.

[0013] According to some embodiments, a delivery system can be used for controlled deployment of a prosthesis or replacement valve. The delivery system can comprise a nose cone shaft, a nose cone, an inner retention shaft, an inner retention ring, a tether retention member, a locking shaft, an outer elongate hollow member shaft, and an outer elongate hollow member. The nose cone can be connected to the distal end of the nose cone shaft. The nose cone can comprise a proximally-facing opening to receive at least a first end of the prosthesis or replacement valve. The inner retention shaft can be slidable over the nose cone shaft. The inner retention ring can be connected to the distal end of the inner retention shaft. The inner retention ring can be configured to engage the first end of the prosthesis or

replacement valve. The tether retention member can be on the inner retention shaft. The locking shaft can be slidable over the inner retention shaft. The locking shaft can be configured to cooperate with the tether retention member to releasably engage a tether attached to the prosthesis or replacement valve. The outer elongate hollow member shaft can be slidable over the locking shaft. The outer elongate hollow member can be connected to the distal end of the outer elongate hollow member shaft. The outer elongate hollow member can have a proximal end and a distal end, the outer elongate hollow member being configured to cover at least the second end of the prosthesis or replacement valve when the first end of the prosthesis or replacement valve is engaged with the inner retention ring and is covered by the nose cone. The outer elongate hollow member can be moveable relative to the nose cone to uncover the second end of the prosthesis or replacement valve while the first end of the prosthesis or replacement valve remains engaged to the inner retention ring and is covered by the nose cone.

[0014] According to some embodiments, the nose cone can comprise a taper towards the distal end of the nose cone. An outer diameter of the nose cone can be similar to an outer diameter of at least one of the outer elongate hollow member shaft and the outer elongate hollow member. An outer diameter of the nose cone can be similar to an inner diameter of at least one of the outer elongate hollow member shaft and the outer elongate hollow member. The inner retention ring can comprise a taper towards a proximal end of the inner retention ring. The inner retention ring can comprise a cavity at or near a distal end of the inner retention ring. The inner retention ring can comprise a compressible member received at least partially within the cavity, the compressible member having a compressed diameter and an expanded diameter. The compressed diameter can be approximately equal to an inner diameter of the nose cone and the expanded diameter can be greater than the inner diameter of the nose cone. The locking shaft can comprise a radial protrusion configured to maintain radial alignment between the locking shaft and the outer elongate hollow member shaft. The locking shaft can comprise a guide member for the tether. The outer elongate hollow member can have a substantially constant diameter throughout the entirety of its length. The diameter of the outer elongate hollow member can be substantially similar to a diameter of the outer elongate hollow member shaft.

[0015] According to some embodiments, the delivery system can comprise an introducer sheath having a proximal end and a distal end slidable over the outer elongate hollow member shaft. The tether retention member can comprise a C-lock. The delivery system can comprise a lock at the distal end of the locking shaft to cover the C-lock to releasably retain a tether therein. The delivery system can comprise a plug shaft having a proximal end and a distal end. The plug shaft can be slidable over the locking shaft and the outer elongate hollow member shaft can be slidable over the plug shaft. The delivery system can comprise a plug at the distal end of the plug shaft to engage the nose cone when the nose cone is retrieved from a patient. The nose cone shaft can be hollow to receive a guidewire.

[0016] According to some embodiments, the delivery system can comprise a prosthesis or replacement valve. A first end of the prosthesis or replacement valve can engage the inner retention ring and can be covered by the nose cone. A second end of the prosthesis or replacement valve can be covered by the outer elongate hollow member shaft. A tether can be connected to the tether retention member, the tether retention member being covered by a lock at the distal end of the locking shaft, the tether wrapping at least partially around the prosthesis or replacement valve and then extending proximally through at least the outer elongate hollow member shaft.

[0017] According to some embodiments, a method of delivery of a prosthesis or replacement valve can comprise: delivering an intraluminal frame assembly to the in situ target location while the frame assembly is in a radially compacted state within an outer member, the frame assembly comprising a frame having a first end, a second end and a longitudinal axis extending between the first and second ends, the frame further comprising a tether encircling at least a portion of the frame, the tether configured to restrain the radial dimension of the frame; at least partially removing the outer member from the frame assembly, wherein the tether restrains the radial dimension of the frame after the outer member is at least partially removed; and releasing the tether from the frame to allow at least a portion of the frame assembly to radially expand.

[0018] According to some embodiments, releasing the tether from the frame can allow the second end of the frame to radially expand while the first end of the frame remains radially restrained. The method can comprise radially expanding the first end of the frame

after releasing the tether to allow the second end of the frame to radially expand. The first end of the frame, prior to radial expansion, can be restrained by a nose cone covering at least the first end of the frame. The outer member can be at least partially removed from the frame assembly by moving the outer member relatively away from the nose cone. The outer member can be at least partially removed in a proximal direction from the frame assembly by moving the outer member relatively away from the nose cone.

[0019] According to some embodiments, the intraluminal frame assembly can comprise a plurality of anchors at its second end, wherein the plurality of anchors extend proximally away from the second end of the frame assembly as the outer member is moved proximally. The plurality of anchors can flip to extend distally away from the second end of the frame assembly after the outer member uncovers the plurality of anchors. The tether can radially restrain the frame assembly during flipping of the anchors. The intraluminal frame assembly can comprise a replacement heart valve. The intraluminal frame assembly can be delivered transapically to a mitral valve location.

[0020] According to some embodiments, a delivery system can be used for controlled deployment of a prosthesis or replacement valve. The delivery system can comprise a delivery catheter, a prosthesis and a cover. The cover can be positioned over a plurality of first anchors of the prosthesis while the first anchors move from pointing in a first longitudinal direction to a second longitudinal direction, thereby preventing or limiting contact between the first anchors and tissue.

[0021] In some embodiments, the prosthesis or replacement valve can comprise a radially compacted replacement valve having a longitudinal axis positioned within the delivery catheter and comprising a plurality of first anchors wherein the first anchors each have an end pointing in a first longitudinal direction in the radially compacted state and the end is configured to change direction to point in a second longitudinal direction, the ends pointing in the second longitudinal direction after the replacement valve is deployed from the delivery catheter.

[0022] In some embodiments, a delivery system can be used for controlled deployment of a replacement valve. The delivery system can comprise a sheath and an expandable cover. The sheath can be configured to surround a radially compacted

replacement valve, wherein retraction of the sheath from off of the radially compacted replacement valve allows the radially compacted replacement valve to at least partially expand. The expandable cover can be advanceable over the sheath prior to retraction to allow for expansion of the replacement valve within the expandable cover as the sheath is retracted to prevent or limit contact between the expanding replacement valve and tissue.

[0023] In certain embodiments, a replacement valve can comprise a plurality of anchors that are configured to change direction during expansion. Each of the anchors can have an end, the end pointing in a first direction prior to expansion and in a second direction after at least partial expansion. Each anchor can rotate at least 45 degrees during the partial expansion.

[0024] The delivery device can be used in a number of different methods, for example, a method of delivery of a replacement valve. A method can comprise: advancing a delivery system holding a radially compacted replacement valve to a native valve, the delivery system comprising: a sheath surrounding the radially compacted replacement valve; and an expandable cover; withdrawing the sheath to allow the replacement valve to at least partially expand within the expandable cover to prevent or limit contact between the expanding replacement valve and tissue.

[0025] In certain embodiments, advancing can further comprise advancing the delivery system to the native valve transapically. An additional step can be advancing the expandable cover over the sheath.

[0026] According to certain embodiments, a method of delivery of a replacement valve can comprise: advancing a delivery system holding a radially compacted replacement valve to a native valve, the delivery system having a longitudinal axis; at least partially expanding the replacement valve radially outward from the longitudinal axis and within an expandable cover to prevent or limit contact between the expanding replacement valve and tissue.

[0027] At least partially expanding the replacement valve can comprise allowing a plurality of anchors to self-expand within the expandable cover. Allowing the plurality of anchors to self-expand can comprise flipping an end of each of the anchors of the plurality of

anchors to change a longitudinal orientation of the end from a first longitudinal direction to a second opposite longitudinal direction.

[0028] A delivery system can be used for controlled deployment of a prosthesis. In some embodiments, the delivery system can include an elongate inner member, an inner retention mechanism on the elongate inner member, and a shaft assembly. The inner retention mechanism can be configured to engage the prosthesis. The shaft assembly can be slidable over the elongate inner member and the inner retention mechanism. The shaft assembly can comprise an outer retention member, a first member and a second member. The outer retention member, together with the inner retention mechanism can be configured to secure the prosthesis on the delivery system. The first and second members can both be connected to the outer retention member and can facilitate delivery of the prosthesis with stretch and compression resistance while retaining the prosthesis during delivery through tortuous pathways.

[0029] In accordance with some embodiments a delivery system can comprise an elongate inner member and a shaft assembly configured to be slidable over the elongate inner member. The shaft assembly can be configured to at least partially radially constrain an expandable prosthesis when the expandable prosthesis is provided over the elongate inner member, and the shaft assembly can comprise a compression member and a tension member concentrically arranged.

[0030] In some embodiments, the compression member can surround the tension member. The delivery system can comprise an outer sheath configured to be slidable over the shaft assembly. The outer sheath can be configured to cover a distal end of the expandable prosthesis when the expandable prosthesis is provided over the elongate inner member. The outer sheath can comprise a slotted hypo tube. The slotted hypo tube can be configured to surround the compression member and the tension member when the outer sheath covers the distal end of the expandable prosthesis. At least a segment of the outer sheath can be formed of ePTFE.

[0031] In some embodiments, a flexible delivery system can comprise an elongate inner member, an inner retention mechanism on the elongate inner member, a mid shaft assembly, and an outer sheath. The delivery system can comprise a handle. The inner

retention mechanism can be configured to engage a radially compacted proximal end of a replacement mitral valve. The mid shaft assembly can be configured to be slidable over the elongate inner member and the inner retention mechanism. The mid shaft assembly can comprise an outer retention member configured to cover at least the radially compacted proximal end of the replacement mitral valve when the proximal end of the replacement mitral valve is engaged with the inner retention mechanism, a first member having a distal end connected to the outer retention member, and a second member having a distal end connected to the outer retention member and extending along the length of the first member. The outer sheath can be configured to be slidable over the mid shaft assembly and configured to cover the distal end of the replacement mitral valve. The first member and second member can be positioned between the handle and the outer retention member.

[0032] In some embodiments, a delivery system can be configured to retain at least a radially compacted proximal end of a replacement mitral valve between an inner retention mechanism and an outer retention member during advancement of the delivery system within the body and the first and second members facilitate advancement with stretch and compression resistance through long and tortuous pathways.

[0033] In some embodiments, the first member can comprise a compression member. The first member can comprise a coiled spring. The second member can comprise a tension member. The second member can comprise a braided wire. The elongate inner member can comprise a tube having a lumen sized and configured to slidably accommodate a guidewire. The delivery system can comprise a nose cone connected to the distal end of the elongate inner member. The inner retention mechanism can comprise a ring comprising a plurality of teeth configured to engage tabs on the proximal end of the prosthesis. The outer retention member can be a ring.

[0034] In some embodiments, the delivery system can comprise a replacement mitral valve having a proximal end and a distal end. The proximal end of the replacement mitral valve can be engaged with the inner retention mechanism on the elongate inner member and can be covered by the outer retention member. The distal end of the replacement mitral valve can be covered by the outer sheath. The outer sheath can comprise a slotted hypo tube. The mid shaft assembly can comprise a plastic tube, wherein both the

compression member and the tension member can be connected to the plastic tube. The plastic tube can be positioned between the handle and the compression and tension members.

BRIEF DESCRIPTION OF THE DRAWINGS

[0035] These and other features, aspects and advantages are described below with reference to the drawings, which are intended to illustrate but not to limit the invention.

[0036] Figure 1A shows an embodiment of a delivery system.

[0037] Figure 1B shows an embodiment of the delivery system of Figure 1A.

[0038] Figures 2A-4B illustrate steps of a deployment method using the delivery system of Figure 1A.

[0039] Figures 5 and 6 show a perspective and side view of an embodiment of a prosthesis in a pre-expanded state.

[0040] Figures 7 and 8 show a perspective and side view of the prosthesis in an expanded state.

[0041] Figure 9 shows another embodiment of a delivery system.

[0042] Figure 10 shows a close-up in view of components of the delivery system of Figure 9.

[0043] Figures 11 and 12 show components of the delivery system of Figure 9 with certain components having been omitted.

[0044] Figure 13 shows further components of the delivery system of Figure 9 with additional components having been omitted.

[0045] Figures 14A-23B illustrate steps of a deployment method using the delivery system of Figure 9.

[0046] Figure 24 illustrates a schematic representation of a prosthesis positioned within the heart.

[0047] Figure 25 shows another embodiment of a delivery system.

[0048] Figure 26 shows a cross-sectional view of the delivery system of Figure 25.

[0049] Figure 27 shows another embodiment of an inner retention mechanism.

[0050] Figure 28 shows a cross-sectional view of the inner retention mechanism of Figure 27.

[0051] Figure 29 shows a cross-sectional view of an embodiment of the inner retention mechanism and nose cone in a first configuration.

[0052] Figure 30 shows a cross-sectional view of the inner retention mechanism and nose cone of Figure 29 in a second configuration.

[0053] Figure 31 shows an embodiment of a delivery system.

[0054] Figure 32 is an exploded view of the distal end of the delivery system of Figure 31.

[0055] Figure 33 is a cross-section view of the distal end of the delivery system of Figure 31.

[0056] Figure 34 shows an exploded view of a mid shaft assembly that may be used in the delivery system of Figure 31.

[0057] Figures 35A-C illustrates a distal end of the delivery system of Figure 31 in a series of positions.

[0058] Figures 36A-C show a handle of the delivery system of Figure 31 in a series of positions.

[0059] Figure 37 shows a prosthesis within a delivery system.

[0060] Figure 38 is a schematic representation showing an access path into the heart.

[0061] Figure 39 illustrates a replacement heart valve deployed in the mitral valve between the left atrium and the left ventricle.

[0062] Figures 40A-B illustrate another embodiment of a delivery system.

DETAILED DESCRIPTION

[0063] The present specification and drawings provide aspects and features of the disclosure in the context of several embodiments of replacement heart valves, delivery devices and methods that are configured for use in the vasculature of a patient, such as for replacement of natural heart valves in a patient. These embodiments may be discussed in connection with replacing specific valves such as the patient's aortic or mitral valve.

However, it is to be understood that the features and concepts discussed herein can be applied to products other than heart valve implants. For example, the controlled positioning, deployment, and securing features described herein can be applied to medical implants, for example other types of expandable prostheses, for use elsewhere in the body, such as within an artery, a vein, or other body cavities or locations. In addition, particular features of a valve, delivery device, etc. should not be taken as limiting, and features of any one embodiment discussed herein can be combined with features of other embodiments as desired and when appropriate. While certain of the embodiments described herein are described in connection with a transapical delivery approach, and certain of the embodiments described herein are described in connection with a transfemoral delivery approach, it should be understood that these embodiments can be used for other delivery approaches. Moreover, it should be understood that certain of the features described in connection with some embodiments can be incorporated with other embodiments, including those which are described in connection with different delivery approaches.

[0064] With reference to Figures 1A and 1B, an embodiment of a delivery device or system **10** is shown. The delivery system can be used to deploy a prosthesis, such as a replacement heart valve, within the body. Replacement heart valves can be delivered to a patient's heart mitral valve annulus in various ways, such as by open surgery, minimally-invasive surgery, and percutaneous or transcatheter delivery through the patient's vasculature. The delivery device **10** can be relatively short to more easily be used in an open heart procedure or other more direct procedures than the percutaneous procedure starting at the leg. At the same time, the delivery device **10** can still be relatively flexible to allow, for example, advancement through the pulmonary veins or the wall of the left atrium and then bending of the delivery device for proper placement at the mitral valve. In this way the illustrated embodiment comprises an elongate, delivery system configured to be advanced in a transapical delivery approach.

[0065] The delivery system **10** can include an elongate shaft assembly **12** comprising a proximal end and a distal end, wherein a handle (not shown) is coupled to the proximal end of the assembly **12**. The elongate shaft assembly **12** can be used to hold the prosthesis for advancement of the same through the vasculature to a treatment location. The

elongate shaft assembly **12** can include an implant retention area **16** that can be used for this purpose. In some embodiments, the elongate shaft assembly **12** can hold an expandable prosthesis in a compressed state at implant retention area **16** for advancement of the prosthesis within the body. The elongate shaft assembly **12** may then be used to allow controlled expansion of the prosthesis at the treatment location. The implant retention area **16** is shown at the distal end of the delivery device, but may also be at other locations.

[0066] The elongate shaft assembly **12** can include one or more subassemblies as will be described in more detail below. The elongate shaft assembly **12** can be configured to deliver a prosthesis positioned within the implant retention area **16** to a treatment location. One or more of the subassemblies can then be moved to allow the prosthesis to be released at the treatment location. For example, one or more of the subassemblies may be movable with respect to one or more of the other subassemblies. The handle can include various control mechanisms that be used to control the movement of the various subassemblies. In this way, the prosthesis can be controllably loaded onto the delivery device **10** and then later deployed within the body.

[0067] With continued reference to Figures 1A and 1B, it can be seen that the subassemblies of the elongate shaft assembly **12** can include one or more outer sheaths **14**, a cover **20**, a capsule **24**, and a nose cone **28**. An implant in a pre-deployed state can be held by the delivery device within the capsule and the nose cone. The capsule and nose cone can be made of polyurethane for atraumatic entry and to minimize injury to tissue. The nose cone or other parts can also be radiopaque to provide for visibility under fluoroscopy.

[0068] The implant or prosthesis can take any number of different forms. A particular example of frame for a prosthesis is shown herein, though it will be understood that other designs can also be used. Additional example designs for a prosthesis are described in U.S. Patent Nos. 8,403,983, 8,414,644, 8,652,203 and U.S. Patent Publication Nos. 2011/0313515, 2012/0215303, 2014/0277390, 2014/0277422, 2014/0277427, the entirety of these patents and publications are hereby incorporated by reference and made a part of this specification.

[0069] Each of the subassemblies can be made of or attached to tubes that slide within one another. In this way, each of the outer sheaths **14**, cover **20**, capsule **24**, and/or

nose cone **28** may move with respect to one or more of the other components or subassemblies. The innermost assembly may include a lumen sized and configured to slidably accommodate a guidewire so that the delivery device **10** can be advanced over the guidewire.

[0070] The various tubes can be a hypodermic tube or hypo tube. The tube can be made from one of any number of different materials including nitinol, stainless steel, and medical grade plastics. The tube can be a single piece tube or multiple pieces connected together. Using a tube made of multiple pieces can allow the tube to provide different characteristics along different sections of the tube, such as rigidity and flexibility. For example, in some embodiments it can be desirable, and/or needful, for the delivery device **10** to have greater flexibility at the distal end of the device, where flexibility is not as necessary for the proximal end.

[0071] Moving now to Figures 2A and 2B, it can be seen that the cover **20** can be advanced over the capsule **24**. The cover **20** can be used to allow the implant to expand while reducing and/or preventing contact between the implant and body tissue during all or part of the expansion process. The cover **20** can be made of a plurality of longitudinal struts sufficiently rigid to advance over the capsule after the delivery device has been positioned within the body at or near a treatment location. For example, the delivery device can be advanced into the left ventricle of the heart for a mitral valve replacement and the cover can then be advanced over the capsule prior to expanding all or part of the implant. The cover can also include a film, sheet, fabric, or other material that can be positioned between the struts. This sheet may or may not be flexible. The sheet can initially be folded within an outer sheath and can expand to a larger size after advancing over the capsule. It will also be understood that in other embodiments, the cover can be positioned over the capsule in an initial state, or prior to advancing the delivery device to the treatment area.

[0072] Once the cover is in position, or while the cover is being advanced into position, the capsule **24** can be withdrawn or otherwise removed from covering the implant **30**. Removing the capsule can allow the implant to expand, partially or in full. In some embodiments, a separate device can control all or part of the expansion of the implant. Figures 3A and 3B show the cover **20** over the implant **30** and the capsule **24** withdrawn.

Withdrawing the capsule can also assist the cover in expanding so as not to impede or restrict expansion of the implant. With the implant partially or fully expanded, the cover can then be withdrawn. Figures 4A and 4B show the delivery device after the cover has been withdrawn, with the implant partially expanded. Figures 4A and 4B also show a tether, wire or suture **32** that can be used to at least partially control expansion of the implant. Also, an end portion of the implant remains compacted in the nose cone **28**. This can allow the implant to be positioned at a heart location prior to full expansion.

[0073] Figures 4A and 4B also illustrates that the implant **30** has a plurality of anchors **34**. In some embodiments, the anchors **34** can point in a first direction prior to expansion and then rotate to point in a second, longitudinally opposite direction after expansion. The anchors can completely flip directions. The cover **20** can beneficially ensure that the anchors do not engage or get caught in tissue during rotation. For example, without a cover during deployment in the left ventricle of the heart, the anchors can easily get caught in the chordae tendineae as they rotate or change directions. Figures 4A and 4B further illustrate that the tether, wire or suture **32** may extend from within the capsule **24** and wrap around the implant **30**, for example at the base of the anchors **34**. The tether, wire or suture **32** may thus partial control expansion of the implant by radially restraining expansion of the implant as the anchors **34** are released from the capsule **24**.

[0074] Figures 5-8 illustrate an example implant **30** that can be used with the delivery device **10**. It can be seen that the anchors **34** can point in a first direction prior to deployment when in the pre-deployment state of Figures 5-6. When deployed, the anchors can rotate to the position shown in Figures 7-8. It will be understood that the implant can be made of a self-expanding material so as to self-expand into the desired shape. The implant of Figures 5-6 can be cut from a tube to the shape shown and the expanded to the shape of Figures 7-8. The implant can then be compressed back to the shape shown in Figures 5-6 or to a similar shape. Further details of the implant are described in the patents and applications incorporated by reference above.

[0075] The embodiment of Figures 9-13 illustrates a delivery device or system **100**. Delivery system **100** can have components, features, and/or functionality similar to those described with respect to delivery device or system **10**. The delivery system **100** can be

used to deploy a prosthesis, such as a replacement heart valve as described elsewhere in this specification, within the body. The delivery system **100** can receive and/or cover portions of the prosthesis such as a first end and second end of the prosthesis. For example, the delivery system **100** may be used to deliver a prosthesis **30** such as illustrated in Figures 7 and 8, where the prosthesis includes a first end **33** and a second end **31**, and wherein the second end **31** is configured to be deployed before the first end **33**. Replacement heart valves can be delivered to a patient's heart mitral valve annulus or other heart valve location in various ways, such as by open surgery, minimally-invasive surgery, and percutaneous or transcatheter delivery through the patient's vasculature. The delivery system **100** can be relatively short to more easily be used in an open heart procedure or other more direct procedures than the percutaneous procedure starting at the leg. At the same time, the delivery system **100** can still be relatively flexible to allow, for example, advancement through the pulmonary veins or the wall of the left atrium and then bending of the delivery device for proper placement at the mitral valve. In some embodiments, the delivery system **100** is particularly suitable for delivering a replacement heart valve to a mitral valve location through a transapical approach (e.g., through the apex of the heart).

[0076] With reference first to the embodiment of Figures 9 and 10, the delivery system **100** can include a handle **110** and a plurality of sheaths and/or shafts such as the illustrated introducer sheath **112** and outer elongate hollow member shaft **114**. As will be described in further detail below, the plurality of shafts can be sized and shaped to be slidable relative to each other. Accordingly, it should be understood that one or more of the plurality of shafts can be concentric with respect to another of the shafts to facilitate slidable movement of the shafts relative to each other. The plurality of shafts can be coupled to one or more other components of the delivery system **100**. In some embodiments, the handle **110** can include a plurality of switches, levers, or other actuatable mechanisms which can be used to control the movement of the one or more shafts of the delivery system **100** and/or to control the operation of other components of the delivery system **100**.

[0077] With continued reference to the embodiment of Figures 9 and 10, the delivery system **100** can include an introducer sheath **112** and an outer elongate hollow member shaft **114**, each having a proximal and distal end. As used to describe the

components of the delivery system, “proximal” refers to a location of the component that is closer to the handle **110**, and “distal” refers to a location of the component that is further from the handle **110**. In some embodiments, the proximal end of the introducer sheath **112** can be coupled to the handle **110**. The introducer sheath **112** can be sized and shaped such that introducer sheath **112** is slidable over the outer elongate hollow member shaft **114**. For example, in some embodiments, the introducer sheath **112** can be fixed relative to the handle **110** and the outer elongate hollow member shaft **114** can be moved within the introducer sheath **112**. In some embodiments, the introducer sheath **112** can be movable relative to the handle **110**. As should be understood from the above disclosure, in some embodiments, the introducer sheath **112** can be omitted and the outer elongate hollow member shaft **114** can form the outer shaft of the delivery system **100**. For example, the embodiment of Figures 25 and 26 illustrates a delivery system **200** without an introducer sheath **112** and the outer elongate hollow member shaft **214** forming an outer shaft.

[0078] With continued reference to the embodiment of Figures 9 and 10, the outer elongate hollow member shaft **114** can optionally have a distal end coupled to a proximal end of an outer elongate hollow member **116**. The outer elongate hollow member **116** can be a sheath or capsule similar to capsule **24** described in connection with delivery system **10**. In some embodiments, the outer elongate hollow member shaft **114** and/or the outer elongate hollow member **116** can cover at least a portion of the prosthesis while the prosthesis is being delivered to the deployment site. For example, the outer elongate hollow member shaft **114** and/or the outer elongate hollow member **116** can cover at least the second end **31** of the prosthesis while the first end **33** of the prosthesis is received within nose cone **118**. In some embodiments, the outer elongate hollow member **116** can also cover the first end of the prosthesis. The outer elongate hollow member **116** can be sized and shaped such that the elongate hollow member **116** can retain the prosthesis in a compressed state as it is delivered to the deployment site. Accordingly, the outer elongate hollow member shaft **114** can function as a capsule shaft. Optionally, the anchors **34** on the prosthesis may extend proximally toward the handle **110** when the prosthesis is covered by the outer elongate hollow member. The outer elongate hollow member **116** can be moveable relative to the nose cone **118** to uncover the second end of the prosthesis while the first end of the prosthesis

remains engaged to an inner retention member (described with respect to Figure 13 below) within the nose cone **118** and remains covered by the nose cone **118**.

[0079] As shown in the illustrated embodiment, the outer elongate hollow member **116** includes a taper at a proximal end such that the proximal end of the outer elongate hollow member **116** has an outer diameter which is less than an outer diameter of the distal end of the outer elongate hollow member **116**. In some embodiments, the outer diameter of the proximal end of the outer elongate hollow member **116** can be similar to, or equal to, the outer diameter of a distal end of the outer elongate hollow member shaft **114**. In some embodiments, the outer elongate hollow member **116** can be collapsible such that, upon retraction towards the introducer sheath **112**, the outer elongate hollow member **116** can collapse into the introducer sheath **112**. The outer elongate hollow member **116** can be formed from a variety of materials, including ePTFE, as well as other biocompatible materials.

[0080] With reference to the embodiment of Figures 25 and 26, in some embodiments, the outer elongate hollow member shaft **214** can extend over the prosthesis and can be sized and shaped such that it can retain the prosthesis in a compressed state as it is delivered to the deployment site. As shown in the illustrated embodiment, the outer elongate hollow member shaft **214** can have a constant or substantially constant outer diameter throughout the entirety, or a substantial portion of the entirety, of its length.

[0081] As shown more clearly in Figure 26, the outer elongate hollow member shaft **214** can have a taper at its distal end. The outer elongate hollow member shaft can include a marker **217** positioned proximate the distal end. In some embodiments, the outer elongate hollow member shaft **214** can include a first portion **215** and a second portion **216**. This can advantageously allow for the use of two types of material for the outer elongate hollow member shaft **214**. For example, as shown in the illustrated embodiment, at least a portion of the first portion **215** can be positioned radially outward from of the second portion **216** relative to a longitudinal axis of the outer elongate hollow member shaft **214**. The first portion **215** can be formed from a relatively rigid material, such as PEBAX, ULTEM, PEAK and any other biocompatible material as desired. This can advantageously provide some degree of rigidity for the outer elongate hollow member shaft **214**. The second portion **216**

can be formed from a more compliant material, such as PTFE, ePTFE and any other biocompatible material as desired. This can advantageously provide a more compliant inner surface for the outer elongate hollow member shaft **214**, which can be beneficial when contacting other components of the delivery system **200** and the prosthesis. In some embodiments, the second portion **216** can be a liner which is applied to the first portion **215**.

[0082] While the illustrated outer elongate hollow member shaft **214** is shown with multiple portions formed from multiple materials, it is also contemplated that the outer elongate hollow member shaft **214** can be formed from a single material. Moreover, in some embodiments, the outer elongate hollow member shaft **214** can include an elongate hollow member similar to outer elongate hollow member **116** which can cover at least a portion of the prosthesis. In some embodiments, the outer elongate hollow member can have a constant or substantially constant outer diameter throughout the entirety, or a substantial portion of the entirety, of its length. The outer diameter of the outer elongate hollow member can be similar to, or equal to, the outer diameter of the outer elongate hollow member shaft **214**. In some embodiments, the outer elongate hollow member can be formed from a material different from the outer elongate hollow member shaft **214**.

[0083] With reference now to the embodiment of Figures 11 and 12, which illustrates delivery system **100** without the outer elongate hollow member **116** being shown, the delivery system **100** can include a plug shaft **120**, a locking shaft **122**, and an inner retention shaft **124**, each having a proximal and distal end. The distal end of plug shaft **120** can be coupled to the proximal end of a plug **126**. In some embodiments, plug shaft **120** can be sized and shaped such that plug shaft **120** is slidable over the locking shaft **122**. For example, in some embodiments, the locking shaft **122** can be moved within the plug shaft **120**. In some embodiments, the plug shaft **120** can be moved over the locking shaft **122**. Moreover, plug shaft **120** can be sized and shaped such that the outer elongate hollow member shaft **114** is slidable over the plug shaft **120**. In some embodiments, the plug **126** can be used to engage the nose cone when the nose cone is retrieved from the patient. For example, the plug **126** can be used to contact the proximal end of the nose cone **118** as the nose cone **118** is retracted proximally toward the plug **126** or as the plug **126** is advanced distally toward the nose cone **118**. As should be understood from the above disclosure, in

some embodiments, the plug shaft **120** and/or the plug **126** can be omitted from the delivery system **100**. For example, the embodiment of Figures 25 and 26 illustrates a delivery system **200** without a plug shaft **120** or plug **126**.

[0084] With reference back to the embodiment of Figures 11 and 12, the nose cone **118** can have a tapered distal end. The nose cone **118** can be formed from a relatively rigid, high durometer material such as a metal. The nose cone **118** can have a length, measured from the distalmost end to a proximalmost end, of between approximately 5 mm to 50 mm, between approximately 10 mm to approximately 40 mm, between approximately 15 mm to approximately 25 mm, approximately 20 mm, any other lengths within these ranges, and any other lengths as desired.

[0085] In some embodiments such as that of Figures 25 and 26, the nose cone **218** can have a more elongated shape. As shown in the illustrated embodiment, the tapered portion can be concave thereby forming a more defined distal tip of the nose cone **218**. As shown more clearly in Figure 26, the nose cone **218** can include a first portion **219** and a second portion **220**. This can advantageously allow for the use of two types of material for the nose cone **218**. For example, as shown in the illustrated embodiment, at least a portion of the first portion **219** can be positioned radially outward from of the second portion **220** relative to a longitudinal axis of the nose cone **218**. The first portion **219** can be formed from a lower durometer material such as urethane, PEBAX, polysilicone and any other biocompatible material as desired. The second portion **220** can be formed from higher durometer materials such as stainless steels, titanium, and any other biocompatible material as desired. This can advantageously provide additional structural support for the nose cone **218**. In some embodiments, the second portion **220** can include threading for attachment to a shaft, such as nose cone shaft **130**. In some embodiments, the first portion **219** can be overmolded onto the second portion **220** and/or attached using mechanical fasteners such as screws, bolts, rivets, and threaded couplings, chemical fasteners, such as adhesives, or other types of fastening techniques such as welding. In some embodiments, the nose cone **218** can be a single unit formed from a single material.

[0086] With reference particularly to the embodiment of Figure 26, the outer diameter of the nose cone **218**, such as the first portion **219** and/or second portion **220**, can be

similar to, or equal to, the outer diameter of an outer shaft and/or outer component, such as the outer elongate hollow member shaft **214**. As shown in the illustrated embodiment, the first portion **219** has an outer diameter which is similar to that of the outer elongate hollow member shaft **214**. This can form a generally smooth transition in diameter between the nose cone **218** and the outer shaft and/or the outer component if and when the nose cone **218** is brought into contact with the outer shaft and/or the outer component. In some embodiments, the nose cone **218** can have an outer diameter of approximately 31 Fr or 32 Fr and the outer shaft and/or outer component can have an outer diameter of approximately 31 Fr or 32 Fr.

[0087] In some embodiments, the outer diameter of the nose cone **218**, such as the first portion **219** and/or second portion **220**, can be similar to, or equal to, the inner diameter of an outer shaft and/or outer component such that the first portion **219** and/or the second portion **220** can be partially received within the outer shaft and/or outer component. In some embodiments, the nose cone **218** can have an outer diameter of approximately 30 Fr and the outer shaft and/or outer component can have an inner diameter of approximately 30 Fr. In some embodiments, the outer shaft can be an outermost shaft of the delivery system.

[0088] With reference back to the embodiment of Figures 11 and 12, the distal end of locking shaft **122** can be coupled to at least a portion of a tether retention assembly **128**. As shown in the illustrated embodiment, the locking shaft **122** is coupled to a lock **129** of the tether retention assembly **128**. Lock **129** can function as a sheath of the tether retention assembly **128**. The lock **129** can be used to cover a corresponding component of the tether retention assembly **128** such as a tether retention member **134**, not shown in Figures 11 and 12 but which will be described in further detail below with respect to Figure 13. In some embodiments, locking shaft **122** can be sized and shaped such that locking shaft **122** is slidable over the inner retention shaft **124**. For example, in some embodiments, the inner retention shaft **124** can be moved within the locking shaft **122**. In some embodiments, the locking shaft **122** can be moved over the inner retention shaft **124**. The locking shaft **122** can cooperate with the tether retention assembly **128** to release a tether **136** (shown in Figure 13) attached to the prosthesis. For example, proximal movement of locking shaft **122** can result in proximal movement of the lock **129** relative to the tether retention member thereby releasing a tether engaged to the tether retention assembly **128**. Moreover, locking shaft **122**

can be sized and shaped such that the outer elongate hollow member shaft **114** is slidable over the locking shaft **122**.

[0089] With continued reference to the embodiment of Figures 11 and 12, the distal end of the inner retention shaft **124** can be coupled to at least a portion of an inner retention member **132** that is positioned within nose cone **118** (not shown in Figures 11 and 12, but shown in Figure 13). In some embodiments, inner retention shaft **124** can be sized and shaped such that inner retention shaft **124** is slidable within the locking shaft **122**. For example, in some embodiments, the inner retention shaft **124** can be moved within the locking shaft **122**. In some embodiments, the locking shaft **122** can be moved over the inner retention shaft **124**. The inner retention shaft **124** can cooperate with the inner retention member **132** and the nose cone **118** to release a first end of the prosthesis from the nose cone **118**. In some embodiments, the first end of the prosthesis can be received within a proximally-facing opening **119** (see Figure 11) and covered by the nose cone **118**. The first end of the prosthesis can also be engaged with the inner retention member **132**. Accordingly, proximal movement of the inner retention shaft **124** can result in proximal movement of the inner retention member relative to the nose cone **118** which can release the first end of the prosthesis from the nose cone **118**. Similarly, distal movement of the nose cone **118** relative to the inner retention shaft **124**, and thus the inner retention member, can also release the first end of the prosthesis from the nose cone **118**.

[0090] In some embodiments such as that of Figure 26, the inner locking shaft **222** can include a radial protrusion **224**, such as an annular disc, and a lock **229** similar to lock **129**. The radial protrusion **224** can assist in maintaining the locking shaft **222** in a desired radial alignment relative to the shaft within which the locking shaft **222** is positioned. For example, as shown in the illustrated embodiment, the radial protrusion can assist in maintaining concentricity between the locking shaft **222** and another shaft such as the outer elongate hollow member shaft **214** in embodiments without a plug shaft **120** and/or plug **126**. In some embodiments, the locking shaft **222** can include a guide member **226** for the tether, wire or suture **32**. As shown in the illustrated embodiment, the guide member can be formed as a hole on the radial protrusion.

[0091] In some embodiments, the locking shaft **222** can be retracted via use of a spring loaded actuator. The spring loaded actuator can be similar to spring **1066** described in connection with Figure 36C.

[0092] With reference now to the embodiment of Figure 13, which illustrates delivery system **100** without the outer elongate hollow member **116**, nose cone **118**, locking shaft **122**, and lock **129** being shown, the delivery system **100** can include a nose cone shaft **130** having a proximal and distal end. The distal end of the nose cone shaft **130** can be coupled to a portion of the nose cone **118**. In some embodiments, nose cone shaft **130** can be sized and shaped such that inner retention shaft **124** is slidable over the nose cone shaft **130**. For example, in some embodiments, the nose cone shaft **130** can be moved within the inner retention shaft **124**. In some embodiments, the inner retention shaft **124** can be moved over the nose cone shaft **130**. Moreover, in some embodiments, the nose cone shaft **130** can be hollow such that the nose cone shaft **130** can receive a guidewire.

[0093] With continued reference to the embodiment of Figure 13, the delivery system **100** can include an inner retention member **132** such as an inner retention ring coupled to the distal end of the inner retention shaft **124**. The inner retention member **132** can include a plurality of slots sized and shaped to receive portions of a first end of the prosthesis. In some embodiments, the slots can extend radially inward. The first end of the prosthesis can be placed in a compressed state such that the first end of the prosthesis is retained between the inner retention member **132** and the nose cone (not shown) when the inner retention member **132** is received within and covered by the nose cone. In some embodiments, when the inner retention member **132** is uncovered, the first end of the prosthesis can expand radially outward from the inner retention member **132** and thereby disengage from the inner retention member **132**.

[0094] In some embodiments such as that of Figures 27 and 28, the inner retention member **232** can have a more elongated design. As shown in the illustrated embodiment, the inner retention member **232** can have a proximal end **234** and a distal end **236** with a plurality of slots **238** sized and shaped to receive portions of a first end of the prosthesis positioned proximate the proximal end **234**. Slots **238** can extend along a longitudinal axis of the inner retention member **232**. In some embodiments, the inner

retention member **232** can include a cavity **239** positioned distal the slots **238**. The cavity **239** can be sized and shaped to receive portions of the first end of the prosthesis. As shown in the illustrated embodiment, the cavity **239** can have an annular shape. In some embodiments, the inner retention member **232** can include a taper towards the proximal end **234**. This can facilitate removal of the inner retention member **232** from the heart by reducing the diameter at the proximalmost end of the inner retention member **232** and reducing the likelihood of snagging on tissue. This can be particularly advantageous in embodiments where the plug shaft **120** and/or plug **126** are not included in the delivery system **100**.

[0095] As shown in the illustrated embodiment, the inner retention member **232** can include a cavity **240** proximate the distal end **236**. The cavity **240** can be formed between one or more radial protrusions, such as ridges **244**, **246**. A compressible member **242**, such as an O-ring, can be received at least partially within the cavity **240**. As shown in the illustrated embodiment, the cavity **240** can have an annular shape.

[0096] With continued reference to the embodiment of Figure 28, in some embodiments the inner retention member **232** can include a first portion **248** and a second portion **250**. This can advantageously allow for the use of two types of material for the inner retention member **232**. For example, as shown in the illustrated embodiment, at least a portion of the first portion **248** can be positioned radially outward from of the second portion **250** relative to a longitudinal axis of the inner retention member **232**. The first portion **248** can be formed from materials such as urethane, PEBAX, polysilicone and any other biocompatible material as desired. The second portion **250** can be formed from higher durometer materials such as stainless steels, titanium, and any other biocompatible material as desired. In some embodiments, the second portion **250** can include threading for attachment to a shaft, such as inner retention shaft **124**. This can advantageously provide additional structural support for the inner retention member **232**. In some embodiments, the first portion **248** can be overmolded onto the second portion **250** and/or attached using mechanical fasteners such as screws, bolts, rivets, and threaded couplings, chemical fasteners, such as adhesives, or other types of fastening techniques such as welding. In some

embodiments, the inner retention member **232** can be a single unit formed from a single material.

[0097] As shown in the embodiment of Figure 29, in some embodiments the compressible member **242** can be sized and shaped such that it can be compressed to a smaller outer diameter. This can allow the compressible member **242** to fit within the nose cone, such as nose cones **118, 218**, when the inner retention member **232** is positioned within the nose cone **218**. In such an embodiment, positioning within the nose cone **218** can maintain the compressible member **242** in this compressed state. Once the compressible member **242** is no longer fully positioned within the nose cone **218**, as shown in the embodiment of Figure 30, the compressible member **242** can expand to a larger outer diameter. In some embodiments, the outer diameter in the relaxed or expanded state can be greater than the inner diameter of the nose cone **218**. In some embodiments, the outer diameter in the relaxed or expanded state can be greater than the outer diameter of the nose cone **218**. This can advantageously facilitate removal of the inner retention member **232** and nose cone **218** from the heart. For example, the compressible member can be positioned against a proximal edge of the nose cone **218** thereby serving as a smoother and less traumatic contact surface.

[0098] With reference back to the embodiment of Figure 13, the delivery system **100** can include a tether retention member **134**. The tether retention member **134** can be attached to the inner retention shaft **124**. As shown in the illustrated embodiment, the tether retention member **134** can be a C-lock having an opening through which a tether **136** can pass. In order to retain the tether **136** within the tether retention member **134**, the end **138** of the tether **136** can be sized and shaped such that the end **138** is prevented from passing through the opening of the tether retention member **134**. For example, the end **138** of the tether **136** can be knotted such that at least one dimension of the end **138** prevents the end **138** from passing through the opening. In the illustrated embodiment, the tether **136** can be released from the tether retention member **134** by passing the tether **136** radially away from and over the tether retention member **134**. The tether **136** can be tensioned and angled such that the tether **136** would pass over the tether retention member **134** when tether retention member **134** is uncovered from the lock **129** (not shown). It should be understood that other

mechanisms can be used for tether retention assembly **128** in lieu of the lock and tether retention member **134** including, but not limited to, clamps which engage the tether **136**. Although not shown, the tether **136** can engage at least a portion of the prosthesis, such as the second end of the prosthesis. For example, in some embodiments, the tether can wrap around at least some portion of the prosthesis and extend at least proximally through at least the outer elongate hollow member **116** and/or the outer elongate hollow member shaft **114**. The end opposite end **138** can be attached to a component of the delivery system **100** such that the tether **136** can be retracted into the delivery system **100** upon release of the tether **136** from the tether retention assembly **128**.

[0099] The embodiments of Figures 14A-23B illustrates steps of a method of operating the delivery system **100** and releasing an intraluminal frame assembly, such as implant **30**, to intraluminal tissue at an in situ target location. The steps of this method can be carried out while the intraluminal frame assembly is in a radially compacted state within an outer member, such as outer elongate hollow member **116**. In some embodiments, the longitudinal axis of the frame assembly, which runs between the first and second ends of the intraluminal frame assembly, can be parallel to and/or concentric with the longitudinal axis of one or more shafts of the delivery system **100**. The steps of this method can be used to transapically deliver a replacement heart valve to a mitral valve location.

[0100] With reference first to the step of Figures 14A and 14B, the delivery system **100** is shown in a preliminary configuration with the outer elongate hollow member **116** covering the implant (not shown) and adjacent to the nose cone **118**. In this configuration, the delivery system **100** has a relatively compact form factor which facilitates delivery of the implant to the in situ target location. As shown in the illustrated embodiment, the outer elongate hollow member **116** can remain wholly outside the introducer sheath **112** in this configuration.

[0101] With reference next to the step of Figures 15A and 15B, once the delivery system **100** has positioned the implant at the in situ target location, the outer elongate hollow member **116** can be moved relatively away from the nose cone **118**, either by proximally retracting the outer elongate hollow member **116** and/or distally advancing the nose cone **118**, to uncover at least a portion of the implant **30**. As shown in the illustrated embodiment, the

outer elongate hollow member **116** can also be moved relatively toward the introducer sheath **112**, either by proximally retracting the outer elongate hollow member **116** and/or distally advancing the introducer sheath **112**, such that the outer elongate hollow member **116** is partially received within the introducer sheath **112**.

[0102] With reference next to the step of Figures 16A and 16B, the outer elongate hollow member **116** can be further moved relatively away from the nose cone **118** to further uncover the implant **30** and/or relatively toward the introducer sheath **112**. As shown in the illustrated embodiment, the second end **31** of the implant **30** has been partially uncovered with both the outer elongate hollow member **116** and the tether **136** restraining the radial dimension of the frame of the implant **30**. It should be noted that the first end **33** of the implant **30** can remain covered by the nose cone **118** during this step such that the first end **33** remains in a radially compacted state.

[0103] With reference next to the step of Figures 17A and 17B, the outer elongate hollow member **116** can be further moved relatively away from the nose cone **118** thereby further uncovering the implant **30** and/or relatively toward the introducer sheath **112**. As shown in the illustrated embodiment, the second end **31** of the implant **30** has been fully uncovered. Moreover, as shown in the illustrated embodiment, the second end **31** of the implant **30** has at least partially expanded in the radial dimension with anchors **34** having been flipped to extend distally away from the second end **31** of the implant **30**. The tether **136** can continue to at least partially restrain the radial dimension of the second end **31** and can advantageously reduce the speed at which the second end **31** radially expands. In some embodiments, the tether **136** can be designed such that the second end **31** remains in the fully compacted state when the second end **31** is fully uncovered. It should be noted that the end (not shown) of the tether **136** remains attached to the tether retention assembly **128**. During this step, tension in the tether **136** can be reduced such that the second end **31** of the implant **30** can be further radially expanded.

[0104] With reference next to the step of Figures 18A and 18B, the lock **129** has been moved relatively away from the tether retention member **134** to release the end **138** of the tether **136**. In so doing, the second end **31** of the implant **30** is allowed to further radially expand. It should be noted that the first end **33** of the implant **30** can remain covered by the

nose cone **118** during this step such that the first end **33** remains in a radially compacted state. With reference next to the step of Figures 19A and 19B, the tether **136** and end **138** can be retracted into the delivery system **100**.

[0105] With reference next to the step of Figures 20A and 20B, the inner retention member **132** and/or the first end **33** of the implant **30** can be moved relatively away from the nose cone **118** such that the first end **33** of the implant **30** can radially expand. This can be achieved by either distally moving the nose cone **118** relative to the inner retention member **132** and/or moving the inner retention member **132** proximally relative to the nose cone **118**. With reference next to the step of Figures 21A and 21B, the plug **126**, attached to the plug shaft **120**, can be moved relatively toward the nose cone **118** to engage the nose cone **118**. The plug **126** and/or plug shaft **120** can cover multiple of the inner components to facilitate extraction of the delivery system **100** from the body after delivery of the implant **30** to the in situ location. As shown in the step of Figures 22A and 22B, the outer elongate hollow member **116** can be further moved relatively toward the introducer sheath **112**. As shown in the step of Figures 23A and 23B, various other components of the delivery system **100** can be moved relatively toward the introducer sheath **112** to reduce the form factor of the delivery system and further facilitate extraction of the delivery system **100** from the body. Figure 24 illustrates the implant **30** positioned within a native valve, such as a native mitral valve.

[0106] With reference to Figure 31, an embodiment of a delivery device or system **1010** is shown. The delivery system can be used to deploy a prosthesis, such as a replacement heart valve, within the body. The illustrated embodiment comprises an elongate, delivery system configured to be advanced through a patient's vasculature in a percutaneous delivery approach. The delivery system **1010** can be rigid and yet flexible to be able to pass through the vasculature while also navigating the curvatures of the same. While the delivery system **1010** is described in connection with a percutaneous delivery approach, and more specifically a transfemoral delivery approach, it should be understood that features of delivery system **1010** can be applied to any other delivery system described herein, including delivery systems **10**, **100**, **200** which are described in connection with a transapical delivery approach. Moreover, features of delivery systems **10**, **100**, **200** can be applied to delivery system **1010**.

[0107] The delivery system **1010** can include an elongate shaft assembly **1012** comprising a proximal end and a distal end, wherein a handle **1014** is coupled to the proximal end of the assembly **1012**. The elongate shaft assembly **1012** can be used to hold the prosthesis for advancement of the same through the vasculature to a treatment location. The elongate shaft assembly **1012** can include an implant retention area **1016** that can be used for this purpose. In some embodiments, the elongate shaft assembly **1012** can hold an expandable prosthesis in a compressed state at implant retention area **1016** for advancement of the prosthesis within the body. The elongate shaft assembly **1012** may then be used to allow controlled expansion of the prosthesis at the treatment location. The implant retention area **1016** is shown at the distal end of the delivery device, but may also be at other locations.

[0108] The elongate shaft assembly **1012** can include one or more subassemblies such as an inner assembly **1018**, a mid shaft assembly **1020**, and an outer sheath assembly **1022**, as will be described in more detail below. The inner assembly **1018**, mid shaft assembly **1020**, and outer sheath assembly **1022** can be configured to deliver a prosthesis positioned within the implant retention area **1016** to a treatment location. One or more of the subassemblies can then be moved to allow the prosthesis to be released at the treatment location. For example, one or more of the subassemblies may be movable with respect to one or more of the other subassemblies. The handle **1014** can include various control mechanisms **1024**, **1026** that be used to control the movement of the various subassemblies as will also be described in more detail below. In this way, the prosthesis can be controllably loaded onto the delivery device **1010** and then later deployed within the body.

[0109] With continued reference to the subassemblies of the elongate shaft assembly **1012**, Figures 32 and 33 respectively illustrate an exploded and cross-sectional view of the same. The inner assembly **1018** may be an elongate member, and in some embodiments, may have a nose cone **1028** on its distal end. The nose cone can be made of polyurethane for atraumatic entry and to minimize injury to venous vasculature. The nose cone can also be radiopaque to provide for visibility under fluoroscopy. Nose cone **1028** can share features of other nose cones described herein, such as nose cones **28**, **118**, **1128**.

[0110] The inner assembly **1018** may include a lumen **1030** sized and configured to slidably accommodate a guidewire so that the delivery device **1010** can be advanced over

the guidewire through the vasculature. The inner assembly **1018** may also be a steerable catheter which may or may not need or use a guidewire.

[0111] The inner assembly **1018** can comprise a tube, such as a hypodermic tube or hypo tube **1032**. The tube can be made from one of any number of different materials including nitinol, stainless steel, and medical grade plastics. The tube can be a single piece tube or multiple pieces connected together. Using a tube made of multiple pieces can allow the tube to provide different characteristics along different sections of the tube, such as rigidity and flexibility. For example, in some embodiments it can be desirable, and/or needful, for the delivery device **1010** to have greater flexibility at the distal end of the device, where flexibility is not as necessary for the proximal end.

[0112] In some embodiments a first segment made of a hypo tube **1032** can extend along a majority of the length of the inner assembly. For example, the illustrated metal hypo tube **1032** extends from a luer fitting **1062** within the handle **1016** (Figures 36A-C) at the proximal end towards the distal end up until a second segment **1034** of the inner assembly **1018** before the implant retention area **1016**. The hypo tube **1032** can provide column strength (pushability) to the inner assembly. The second segment **1034** of the inner assembly **1018** can be made of a more flexible material. For example, the second segment can comprise a wire **1034** such as a multi-stranded wire, wire rope, or wire coil. The wire **1034** can surround a more flexible tube, such as a plastic tube, or it may be formed as a tube without any additional inner materials or core. Thus, in some embodiments, the wire **1034** can be a hollow core wire rope. The wire **1034** can provide the inner assembly **1018** with strength, similar to the hypo tube, but it can also provide more flexibility to allow for navigating the curvatures of the vasculature, such as within the heart.

[0113] In some embodiments, the wire **1034** extends distally from the hypo tube **1032** to the nose cone **1028**. In some embodiments, the inner assembly **1018** can include a third segment **1036**. The third segment can be positioned at the implant retention area **1016** and between the second segment **1034** and the nose cone **1028**. For example, the third segment can comprise a second wire **1036** such as a multi-stranded wire, wire rope, or wire coil. The second wire **1036** can surround a more flexible tube, such as a plastic tube, or it

may be formed as a tube without any additional inner materials or core. The second wire **1036** may also be a hollow core wire rope.

[0114] In some embodiments, the second wire **1036** can have an outer diameter smaller than the first wire **1034**. As the second wire is positioned at the implant retention area **1016**, it can be desirable that the second wire **1036** have as small an outer diameter as possible, to reduce the size of the delivery device loaded with a prosthesis. The prosthesis may be able to provide some of the desired rigidity or strength characteristics of the delivery device at the implant retention area **1016** and this may allow the segment **1036** to have an even smaller outer diameter.

[0115] In some embodiments, the third segment **1036** can comprise a plastic tube. The plastic tube can extend from the nose cone **1028** to the first segment **1032**. The second segment **1034** can surround the third segment **1036** and be positioned between the first segment **1032** and the implant retention area **1016**. For example, the second segment **1034** can be a hollow core wire rope that surrounds the third segment **1036**.

[0116] The inner assembly **1018** can also include a prosthesis retention mechanism such as an inner retention ring **1038** that can be used to engage with the prosthesis. The inner retention ring **1038** can share features with other retention members, such as inner retention members **132**, **232**. Examples of prostheses that may be engaged on the prosthesis retention mechanism when the delivery device **1010** is used to deliver a replacement heart valve are described in U.S. Patent Nos. 8,403,983, 8,414,644, 8,652,203 and U.S. Patent Publication Nos. 2011/0313515, 2012/0215303, 2014/0277390, 2014/0277422, 2014/0277427, the entirety of these patents and publications are hereby incorporated by reference and made a part of this specification. For example, the inner retention ring **1038** can include a plurality of slots configured to engage with struts on the prosthesis. The inner retention ring **1038** can be mounted on the tube of the inner assembly **1018**, such as at the junction of the distal end of the second segment **1034** and the proximal end of the third segment **1036**. The inner retention ring **1038** can also be part of the implant retention area **1016**, and may be at the proximal end of the implant retention area **1016**.

[0117] Struts or other parts of a prosthesis can be engaged with the inner retention ring **1038** and an outer retention member can cover both the prosthesis and the inner retention

ring **1038** to secure the prosthesis on the delivery device **1010**. This outer retention member can be part of one of the other one or more subassemblies of the elongate shaft assembly **1012**.

[**0118**] In the illustrated embodiment, the outer retention member is a support tube or outer retention ring **1040** which is part of the mid shaft assembly **1020**. The mid shaft assembly **1020** can slide over the inner assembly **1018** and the outer retention ring **1040** can slide over the inner assembly **1018** and the inner retention ring **1038** to encircle the inner retention ring **1038**. In this way the outer retention ring **1040** can be used to help secure a prosthesis to or release it from the delivery device **1010**. The inner and outer retention rings and the delivery device generally may be similar to those disclosed in U.S. Patent No. 8,414,644 and 8,652,203, the entire contents of both of which are hereby incorporated by reference herein and made a part of this specification. This is inclusive of the entire disclosure, including other apparatuses and methods described therein, and is not in any way limited to the disclosure of the inner and outer retentions and/or the delivery device.

[**0119**] Like the inner assembly **1018**, the mid shaft assembly **1020** can be a single piece tube or multiple pieces connected together to provide different characteristics along different sections of the tube. As has been mentioned, in some embodiments it can be desirable, and/or needful, for the delivery device **1010** to have greater flexibility at the distal end of the device, where flexibility is not as necessary for the proximal end. The illustrated mid shaft assembly **1020** has a first segment **1042**, a second segment **1044**, and a third segment **1040** being the outer retention ring **1040**. The first segment **1042** is preferably formed of plastic, but could also be a metal hypo tube or other material.

[**0120**] The second segment **1044** is shown including a metal coil spring **1046** which is connected to the outer retention ring **1040** at one end and to the plastic tube **1042** at the other end. Figure 34 shows an exploded view of the mid shaft assembly **1020** including the components of the second segment **1044**. As shown, the second segment **1044** can include an inner member **1048** and an outer member **1046**. The mid shaft assembly **1020** also can include various coupling members **1050**, **1052**, **1054** that can be used to connect the different first and third segments to the second segment, as well as to connect the inner **1048** and outer **1046** members.

[0121] One of the inner **1048** and outer **1046** members can be a compression member and the other can be a tension member. The compression member and the tension member can be concentrically arranged. They are also both highly flexible. As shown, the outer member is a coil spring **1046** and the inner member is a braided wire **1048**. A length of a coil spring or a braided wire can be highly flexible and can be moved in many directions. For example, they can both be twisted around a full 180 degrees or more, depending on the length of the material. The compression member and the tension member can provide a balance of forces with flexibility without over stretching or too much shortening.

[0122] It will be understood that a compression member by itself, such as a coil spring and/or HDPE tube, can provide certain benefits, but also has certain draw backs. A compression member can apply a distally directed force on the inner retention member **1038** and can oppose proximally directed forces. But, compression members do not generally perform well under tension. For example, a spring can stretch when under tension. It will be understood, that when the mid shaft assembly **1020** is being slid away from the inner retention member **1038**, for example, to release a prosthesis, it could experience resistance that could cause the spring to stretch such that the prosthesis is not released. Adding a tension member, such as a braided wire, can prevent this from occurring as the tension member can limit the amount of stretching of the compression member. The braided wire helps pull back the spring, but also has some give to expand and compress with the spring. The tension member can provide the required flexibility but resist stretching. Thus the compression and tension members can beneficially allow for increased flexibility while also providing more reliable implant release capabilities.

[0123] As has been mentioned, the mid shaft assembly **1020** can include various coupling members **1050**, **1052**, **1054**. A first coupling member **1050** can be used to connect the first **1042** and second **1044** segments. The first coupling member **1050** can be made of metal or plastic and is shown with a plug end to form a friction fit with the first member **1042**. The second member can be fastened to the first coupling member **1050** such as by adhesive or ultrasonic welding. In some embodiments the inner member can attach to an inside surface of the first coupling member **1050** and the outer member **1046** can attach to an outside surface of the first coupling member **1050**. The second coupling member **1052** can

attach to the inner and outer members in a similar manner. The third segment **1040** can be attached to the second segment **1044** by the interaction of the second **1052** and third **1054** coupling members. The third coupling member **1054** can be received in the second coupling member **1052** via snap fit connection with the third segment securely positioned between the second and third coupling members. It will be understood that this is just one example of how the various segments could be connected.

[0124] In some embodiments the sheath assembly **1012** has only two subassemblies which can be the inner **1018** and mid shaft **1020** assemblies as have been described. In some such embodiments, though the outer retention ring **1040** is shown as a relatively short ring, it could also be elongate and could extend from the inner retention ring **1038** to the nose cone **1028** when in a fully advanced position. In addition, the outer member **1046** such as a coil spring could be covered with a sheath such as sheath made of polytetrafluoroethylene (PTFE) or expanded polytetrafluoroethylene (ePTFE).

[0125] Returning now to Figures 32 and 33, the outer sheath assembly **1022** will be described. The outer sheath assembly **1022** is disposed so as to be slidable over the inner assembly **1018** and the mid shaft assembly **1020**. Like the inner assembly **1018** and the mid shaft assembly **1020**, the outer sheath assembly **1022** can be a single piece tube or multiple pieces connected together to provide different characteristics along different sections of the tube. As has been mentioned, in some embodiments it can be desirable, and/or needful, for the delivery device **1010** to have greater flexibility at the distal end of the device, where flexibility is not as necessary for the proximal end. The illustrated outer sheath assembly **1022** has a first segment **1056**, a second segment **1058**, and a third segment **1060**.

[0126] The first segment **1056** is a tube and is preferably formed plastic, but could also be a metal hypo tube or other material. In some embodiments, the tube **1056** is formed of a polyether block amide (PEBA) or other type of a thermoplastic elastomer (TPE). In particular the tube **1056** can be a wire braided reinforced PEBA which can enhance pushability and trackability.

[0127] The second segment **1058** can be a metal hypo tube which in some embodiments may be cut or have slots. The hypo tube can provide structural rigidity, while the cuts can provide for flexibility in the hypo tube. The second segment can be a laser cut

nitinol tube designed to allow adequate flexibility but with sufficient column strength to provide finite control for stepwise retraction of the outer sheath during deployment. For example, the remaining material can form a series of interconnected “H”s that are offset by 90 degrees. As another example, the hypo tube can be cut into a series of rings with small connecting members extending between the rings. For example two equally spaced connecting members can be used to connect two rings and the subsequent connecting members can be offset 90 degrees. Other numbers of connecting members such as one, two, three, four, etc. can also be used.

[0128] The tube **1058** can be covered or encapsulated with a layer of ePTFE, PTFE, or other material so that the outer surface of the outer sheath assembly is generally smooth.

[0129] The third segment **1060** can be a tube formed of a plastic or metal material. In a preferred embodiment, the third segment is formed of ePTFE or PTFE. In some embodiments this sheathing material can be relatively thick to prevent tearing and to help maintain a self-expanding implant in a compacted configuration. In some embodiments the material of the third segment **1060** is the same material as the coating on the cut hypo tube **1058**.

[0130] Looking now to Figures 35A-C, the relative movements of the one or more subassemblies of the elongate shaft assembly **1012** will be described. Figure 35A shows the outer sheath assembly **1022** in its distal most position. The third segment **1060** of the outer sheath is shown in contact with the proximal end of the nose cone **1028**. In this position, a prosthesis can be held within the elongate shaft assembly **1012** for advancement of the same through the vasculature to a treatment location.

[0131] Once at the desired location, the outer sheath assembly **1022** can be retracted proximally to expose a portion of or all of a prosthesis in the implant retention area **1016**. Figure 35B illustrates the elongate shaft assembly **1012** with the outer sheath assembly **1022** can be retracted proximally to expose the entire implant retention area **1016**. The mid shaft assembly **1020** can then be retracted as shown in Figure 35C. This can allow any portion of the prosthesis engaged between the inner retention member **1038** and the outer

retention member **1040** to be released. In some delivery methods this would be the last step to fully deploying the prosthesis such as replacement heart valve.

[0132] Figures 36A-C show the corresponding position of the control mechanisms and components at the handle from the configurations of Figures 35A-C. To move the outer sheath assembly **1022** between the advanced position (Figure 35A) and the retracted position (Figure 35B), the control mechanism **1024** is actuated. As shown, the control mechanism **1024** is a retraction knob that is rotated. This causes a lead screw **1064** connected to the first segment **1056** of the outer sheath assembly **1022** to move proximally (Figure 36B). Then, to move the mid shaft assembly **1020**, the control mechanism **1026** is pulled backwards (Figure 36C). Springs **1066** can be used to give feedback to the user and to better control the movement of the mid shaft assembly **1020** to thereby provide a controlled release of the prosthesis. In addition, the springs **1066** can maintain a continuous extension force between the inner assembly **1018** and the mid shaft assembly **1020** to keep the inner retention member **1038** bottomed out inside the outer retention member **1040** so that the distal tip of the delivery device **1010** maintains maximum flexibility and freedom of motion and the prosthesis does not unlock and prematurely deploy.

[0133] Aspects of the handle **1014**, can be used in conjunction with other delivery devices described herein, such as delivery devices **10**, **100**, **200**, **1100**. For example, in some embodiments, the control mechanism **1024** can be used with a lead screw **1064** as shown in Figures 36A and 36B connected to an outer elongate hollow member shaft **114**, to control movement of the outer elongate hollow member shaft **114** and/or elongate hollow member **116** as shown in Figure 9. Moreover, springs **1066** as shown in Figure 36C can be operably coupled to the locking shaft **122** to control movement of the locking shaft **122** and/or lock **129** as shown in Figure 11. For example, the springs **1066** can be used to bias locking shaft **122** in a retracted position such that actuation of a switch can cause the locking shaft **122** to move towards the retracted position. This can, in some embodiments, facilitate release of the tether, wire or suture **32** from the tether retention assembly **128**.

[0134] The handle can also include any number of luers that can allow all subassemblies to be perfused with saline. The perfusion of saline can eliminate or reduce air

embolism risk due to catheter use and can also provide flushing capability for the delivery procedure.

[0135] Turning now to Figure 37, an embodiment of a delivery device **1010** is shown with a schematic representation of a prosthesis **1070**, such as a replacement heart valve, within the implant retention area **1016**. As has been discussed, the outer retention ring **1040** and the outer sheath **1022** can cooperate to hold the replacement heart valve **1070** in a compacted configuration. The inner retention ring **1038** is shown engaging the struts **1072** at the proximal end of the heart valve **1070**. For example, teeth **1068** on the inner retention ring **1038** can engage the struts **1072** which may end in tabs on the proximal end of the heart valve **1070**. The outer retention ring **1040** can be positioned over the inner retention ring **1038** so that the proximal end of the replacement heart valve **1070** is trapped therebetween, securely attaching it to the delivery device **1010**. The prosthesis **1070** can include one or more sets of anchors, such as distal anchors **1080** and proximal anchors **1082**. The prosthesis **1070** may be similar to the replacement heart valves disclosed in U.S. Patent Nos. 8,403,983, 8,414,644 and 8,652,203, and U.S. Patent Publication Nos. 2011/0313515, 2012/0215303, 2014/0277390, 2014/0277422, 2014/0277427, the entirety of these patents and publications are hereby incorporated by reference and made a part of this specification.

[0136] The delivery device **1010** may be provided to users with a prosthesis **1070** preinstalled. In other embodiments, the prosthesis **1070** can be loaded onto the delivery device shortly before use, such as by a physician or nurse.

[0137] Methods of use of the delivery device in connection with a replacement mitral valve will now be described. In particular, the delivery device **1010** can be used in a method for percutaneous delivery of the replacement mitral valve to treat patients with moderate to severe mitral regurgitation. The below methods are just a few examples of the how the delivery device may be used. It will be understood that the delivery devices described herein can be used as part of other methods as well.

[0138] As shown in Figure 38, in one embodiment a guidewire **1076** can be placed in the ipsilateral femoral vein **1074** and advanced to the right atrium. A transseptal puncture using known techniques can then be performed to obtain access to the left atrium. The guidewire **1076** can then be advanced in to the left atrium and then to the left ventricle.

Figure 38 shows a guidewire **1076** extending from the ipsilateral femoral vein **1074** to the left atrium **1078**. A guidewire snare can be placed in the descending aorta through the ipsilateral femoral artery. The guidewire can be advanced into the ascending aorta and then the snare can be used to snare the guidewire. The guidewire snare can then be withdrawn to externalize the guidewire from the ipsilateral femoral artery. The physician now has access to both ends of the guidewire. It will be understood that one or more introducer sheaths, catheters and/or guidewires may need to be used to get a guidewire externalized at both the ipsilateral femoral vein and the ipsilateral femoral artery. In addition, the initial guidewire discussed above may not be the same as the ultimate externalized guidewire. As will be explained in more detail below, having an externalized guidewire can be useful for positioning the delivery device, especially the distal end of the delivery device, and for helping the delivery device turn some corners. Some embodiments may not use an externalized guidewire. For example, a steerable catheter may be used instead of the externalized guidewire.

[0139] With the guidewire in place, the delivery device **1010** can be advanced over the guidewire through the lumen **1030**. The delivery device can then be advanced to the right atrium, through the septal puncture and the left atrium and into the left ventricle. A steering snare may be used to help advance and position the delivery device correctly. In addition, tension can be applied to one end of the externalized guidewire to help advance and position the delivery device. These additional helps can be particularly useful to get the delivery device to make the bend from extending up into the right atrium and then extending down into the left ventricle.

[0140] The construction and flexibility of the delivery device can allow it to make the relatively sharp turns described above, in particular the turns from entering the right atrium to the septum and then from the septum to the mitral valve. It should be understood that the bending experienced by the delivery device especially between the right atrium and the mitral valve are relatively complex and are generally not in a single plane. This part of the delivery device may experience bending between 110-180 degrees and typically between 130-160 degrees, of course this is dependent on the actual anatomy of the patient.

[0141] Though the entire elongate shaft assembly **1012** may be experiencing some bending or flex, typically it is predominately the second segments **1034**, **1044**, **1058** of the subassemblies (Figure 32) that will be experiencing most of the bending. This can be both when making the turns as the delivery device is being advanced, and also when the prosthesis is being positioned at the mitral valve. The nose cone **1028** can also be flexible and may be bent during turning and at various other times during the procedure.

[0142] The second segments **1034**, **1044**, **1058** can have a bendable length that is substantially aligned with one another. The second segments **1034**, **1044**, **1058** may each have a bendable length of at least between about 3.5 to 4 inches (8.9 to 10.2 cm). In some embodiments, the second segment **1058** of the outer sheath can have a bendable length of about 3 5/8 inches (9.2 cm), the second segment **1044** of the mid shaft can have a bendable length of about 4 3/4 inches (12.1 cm), and the second segment of the inner assembly can have a bendable length of about 5.5 to 6 inches (14 to 15.2 cm). In some embodiments, the relative bendable lengths of the second segments can increase going from the outermost subassembly to the innermost subassembly of the elongate shaft assembly **1012**.

[0143] The delivery device can include a radially-compacted replacement mitral valve **1070** that has been preloaded within the implant retention area **1016**. With the distal end of the delivery device **1010** within the left ventricle, the operator can begin to deploy the replacement mitral valve. Using one or more of the delivery device, the guidewire, and a snare, the distal end of the delivery device can be positioned to be substantially perpendicular to the plane of the mitral annulus. It can also be positioned so that the tips of the distal most anchors **1080** on the replacement valve **1070** are midway between a plane formed by the top of the mitral annulus and a plane formed by the tops of the papillaries. The chordae tendineae extend between the native leaflets attached to the mitral annulus and the papillaries.

[0144] The user can then begin rotating the retraction knob **1024** to retract the outer sheath assembly **1022** until the distal most anchors **1080** begin to extend out from the outer sheath assembly **1022**. Retracting the outer sheath assembly **1022** can allow the valve to self-expand. In some embodiments, the outer sheath assembly **1022** can be at least partially retracted. The distal anchors **1080** can then be positioned between the chordae tendineae. The angle and depth of the distal anchors **1080** then be adjusted to engage one or

more leaflet of the mitral valve. Thus, the distal anchors **1080** can be move back towards the annulus and in some embodiments may engage the leaflet and/or the ventricular side of the annulus. At the same time, the proximal end of the replacement heart valve **1070** can remain retained by the delivery device in an at least partially radially compacted state. This can allow the position of the replacement heart valve **1080** to still be readily adjusted.

[0145] In some embodiments, the distal anchors **1080** can be positioned first at one side of the left ventricle to engage the chordae tendineae and one valve leaflet before engaging the other side and the other leaflet. As the mitral valve is a bicuspid valve, the delivery device **1010** can be used to attach the distal anchors **1080** first to the posterior leaflet and then to anterior leaflet. This second part can be done after the replacement heart valve **1070** is expanded or further expanded by further retracting the outer sheath assembly **1022**.

[0146] In some embodiments, the entrance route of the delivery device **1010** into the left atrium **1078** can bias the delivery device **1010** towards one side of the mitral valve. For example, the delivery device **1010** may be biased towards the posterior leaflet of the mitral valve. This can facilitate securing the distal anchors **1080** to the posterior side or the posterior leaflet first, prior to expanding or further expanding the replacement heart valve **1070**. The distal anchors **1080** can then be secured to the anterior side of the mitral valve or to the anterior leaflet.

[0147] After the distal anchors **1080** are released, the delivery device **1010** and replacement heart valve **1080** can be moved proximally, which in some embodiments, causes the distal anchors to engage the native leaflets and/or native valve annulus. In addition to physically moving the delivery device, this may also be done by pushing the guidewire from the venous side towards the mitral annulus. Once the distal anchors **1080** are properly placed, the delivery device **1010** can then release the proximal anchors **1082** and the proximal end of the replacement heart valve **1070**. This can allow further self-expansion of the replacement heart valve **1070** so that the proximal anchors **1082** engage the upstream or atrial side of the native annulus, and the replacement heart valve **1070** is deployed in operational condition. This can be by fully retracting the outer sheath assembly **1022**, such as by rotating the control knob **1024**, until the replacement valve **1070** has reached its fully expanded state.

[0148] The outer retention ring **1040** can then be moved away from the inner retention ring **1038** to release the proximal end of the replacement valve **1070** from the delivery device **1010**. This can be done by moving the control mechanism **1026** on the handle **1014** downward which is connected to the outer retention ring **1040**. The proximal anchors **1082** can flare radially outward under the self-expansion force of the valve **1070** and engage with the upstream or atrial side of the native mitral valve annulus. Foreshortening of the valve **1070** can cause the distal and proximal anchors to move towards one another to securely grasp the native mitral valve annulus and the leaflets between their opposingly directed anchor tips, and the replacement heart valve **1070** is fully and securely installed as can be seen in Figure 39. The delivery device **1010** can then be removed from the body.

[0149] It will be understood that in some embodiments the replacement heart valve **1070** may not be self expanding, and the partial and full deployment may be accomplished by one or more inflatable balloons or the like. In addition, one or more inflatable balloons may be a part of the delivery device, such as part of the inner assembly **1018** and can be positioned at the implant retention area **1016** as part of the third segment **1036**.

[0150] Looking at Figure 39, a schematic representation of the replacement heart valve **1070** is depicted installed in a human heart **1084**. The heart is shown in cross-section, and represents typical anatomy, including a left atrium **1078** and left ventricle **1086**. The left atrium **1078** and left ventricle **1086** communicate with one another through a mitral annulus **1098**. Also shown schematically in Figure 39 is a native anterior mitral leaflet **1090** having chordae tendineae **1092** that connect a downstream end of the anterior mitral leaflet **1090** and to the left ventricle **1086**.

[0151] As shown, the replacement heart valve **1070** is disposed so that the mitral annulus **1098** is between the distal anchors **1080** and the proximal anchors **1082**. All or most of the replacement heart valve **1070** extends into the left atrium **1078**. The portion of the replacement heart valve **1070** disposed upstream of the annulus **1098** (toward the left atrium) can be referred to as being positioned supra-annularly. The portion generally within the annulus **1098** is referred to as positioned intra-annularly. The portion downstream of the annulus is referred to as being positioned sub-annularly (toward the left ventricle). In the

illustrated embodiment, only a part of the foreshortening portion is positioned intra-annularly or sub-annularly, and the rest of the replacement heart valve **1070** is supra-annular.

[0152] Replacement heart valves can be delivered to a patient's heart mitral valve annulus in various ways, such as by open surgery, minimally-invasive surgery, and percutaneous or transcatheter delivery through the patient's vasculature.

[0153] Looking now at Figures 40A-B, another embodiment of a delivery device **1110** is shown. The delivery device **1110** can function in a similar manner to that described above. The delivery device **1110** can include components which share similar structure to those of other delivery devices described herein, such as delivery devices **10, 100, 200, 1010**. For example, such components can include, but are not limited to, elongate shaft assemblies **1012, 1112**, handles **1014, 1114**, implant retention areas **1016, 1116**, inner assemblies **1018, 1118**, mid shaft assemblies **1020, 1120**, outer sheath assemblies **1022, 1122** control mechanisms **1024, 1026, 1124, 1126**, nose cones **28, 118, 1028, 1128**, hypo tubes **1032, 1132**, segments **1036, 1136**, inner retention rings and mechanisms **132, 232, 1038, 1138**, outer retention rings **1040, 1140**, segments **1042, 1044, 1142, 1144**, outer members **1046, 1146**, segments **1058, 1060, 1158, 1160** and/or lead screws **1064, 1164**.

[0154] As shown in the illustrated embodiment, a primary difference between the delivery device **1010** and the delivery device **1110** is the length of the elongate shaft assemblies **1012, 1112**. It will be appreciated that a short elongate shaft assembly **1112** can be more easily used in an open heart procedure or other more direct procedures than the percutaneous procedure starting at the leg that has been described above with respect to delivery device **1010**. For example, the delivery device **1110** can be used in procedures such as a transapical procedure as described above. At the same time, the delivery device **1110** can still be relatively flexible to allow, for example, advancement through the pulmonary veins or the wall of the left atrium and then bending of the delivery device for proper placement at the mitral valve. The delivery device **1110** can share features with delivery devices described herein, such as delivery devices or systems **10, 100, 200, 1010**.

[0155] The construction and flexibility of the delivery device can allow it to make the relatively sharp turns described above. It should be understood that the bending experienced by the delivery device may be relatively complex and are generally not in a

single plane. This part of the delivery device may experience bending between 65-130 degrees; of course this is dependent at least partially on the actual anatomy of the patient.

[0156] Though the entire elongate shaft assembly **1112** may be experiencing some bending or flex, it is predominately the second segments **1134, 1144, 1158** of the subassemblies that will be experiencing most of the bending. This is both when making the turns as the delivery device is being advanced, and also when the prosthesis is being positioned at the mitral valve. The nose cone **1128** can also be flexible and may be bent during turning and at various other times during the procedure. In some embodiments of the delivery device **1110**, the second segments can extend from the first segments to the handle. Some subassemblies may or may include the first segments described above with respect to the delivery device **1110**. The second segments **1134, 1144, 1158** can have a bendable length that is substantially aligned with one another. The second segments **1134, 1144, 1158** may each have bendable lengths similar to those described above for second segments **1034, 1044, 1058**, though they may also be longer or shorter. For example the second segment **1158** of the outer sheath assembly may extend from the first segment **1160** to the screw **1164**, while the other second segments **1134, 1144** may be shorter.

[0157] It will be understood that the delivery devices, such as delivery devices **10, 100, 200, 1010, 1110** can include many additional features similar to those described in U.S. Patent Nos. 8,414,644 and 8,652,203, the entirety of each of which are hereby incorporated by reference and made a part of this specification. For example, the nose cone can include a prosthesis retention mechanism such as an inner retention ring that can be used to engage with the prosthesis as may be described in these applications. Struts or other parts of a prosthesis can be engaged with the inner retention ring and the nose cone can cover both the prosthesis and the inner retention ring to secure the prosthesis on the delivery devices **10, 100, 200, 1010, 1110**. In addition, the delivery device can be used in delivery methods similar to those described in the above referenced patents and application.

[0158] Any value of a threshold, limit, duration, etc. provided herein is not intended to be absolute and, thereby, can be approximate. In addition, any threshold, limit, duration, etc. provided herein can be fixed or varied either automatically or by a user. Furthermore, as is used herein relative terminology such as exceeds, greater than, less than,

etc. in relation to a reference value is intended to also encompass being equal to the reference value. For example, exceeding a reference value that is positive can encompass being equal to or greater than the reference value. In addition, as is used herein relative terminology such as exceeds, greater than, less than, etc. in relation to a reference value is intended to also encompass an inverse of the disclosed relationship, such as below, less than, greater than, etc. in relations to the reference value.

[0159] While certain embodiments have been described, these embodiments have been presented by way of example only, and are not intended to limit the scope of the disclosure. Indeed, the novel methods and systems described herein may be embodied in a variety of other forms. Furthermore, various omissions, substitutions and changes in the systems and methods described herein may be made without departing from the spirit of the disclosure. The accompanying claims and their equivalents are intended to cover such forms or modifications as would fall within the scope and spirit of the disclosure. Accordingly, the scope of the present disclosure is defined only by reference to the claims presented herein or as presented in the future.

[0160] Features, materials, characteristics, or groups described in conjunction with a particular aspect, embodiment, or example are to be understood to be applicable to any other aspect, embodiment or example described in this section or elsewhere in this specification unless incompatible therewith. All of the features disclosed in this specification (including any accompanying claims, abstract and drawings), and/or all of the steps of any method or process so disclosed, may be combined in any combination, except combinations where at least some of such features and/or steps are mutually exclusive. The protection is not restricted to the details of any foregoing embodiments. The protection extends to any novel one, or any novel combination, of the features disclosed in this specification (including any accompanying claims, abstract and drawings), or to any novel one, or any novel combination, of the steps of any method or process so disclosed.

[0161] Furthermore, certain features that are described in this disclosure in the context of separate implementations can also be implemented in combination in a single implementation. Conversely, various features that are described in the context of a single implementation can also be implemented in multiple implementations separately or in any

suitable subcombination. Moreover, although features may be described above as acting in certain combinations, one or more features from a claimed combination can, in some cases, be excised from the combination, and the combination may be claimed as a subcombination or variation of a subcombination.

[0162] Moreover, while operations may be depicted in the drawings or described in the specification in a particular order, such operations need not be performed in the particular order shown or in sequential order, or that all operations be performed, to achieve desirable results. Other operations that are not depicted or described can be incorporated in the example methods and processes. For example, one or more additional operations can be performed before, after, simultaneously, or between any of the described operations. Further, the operations may be rearranged or reordered in other implementations. Those skilled in the art will appreciate that in some embodiments, the actual steps taken in the processes illustrated and/or disclosed may differ from those shown in the figures. Depending on the embodiment, certain of the steps described above may be removed, others may be added. Furthermore, the features and attributes of the specific embodiments disclosed above may be combined in different ways to form additional embodiments, all of which fall within the scope of the present disclosure. Also, the separation of various system components in the implementations described above should not be understood as requiring such separation in all implementations, and it should be understood that the described components and systems can generally be integrated together in a single product or packaged into multiple products.

[0163] For purposes of this disclosure, certain aspects, advantages, and novel features are described herein. Not necessarily all such advantages may be achieved in accordance with any particular embodiment. Thus, for example, those skilled in the art will recognize that the disclosure may be embodied or carried out in a manner that achieves one advantage or a group of advantages as taught herein without necessarily achieving other advantages as may be taught or suggested herein.

[0164] Conditional language, such as “can,” “could,” “might,” or “may,” unless specifically stated otherwise, or otherwise understood within the context as used, is generally intended to convey that certain embodiments include, while other embodiments do not include, certain features, elements, and/or steps. Thus, such conditional language is not

generally intended to imply that features, elements, and/or steps are in any way required for one or more embodiments or that one or more embodiments necessarily include logic for deciding, with or without user input or prompting, whether these features, elements, and/or steps are included or are to be performed in any particular embodiment.

[0165] Conjunctive language such as the phrase “at least one of X, Y, and Z,” unless specifically stated otherwise, is otherwise understood with the context as used in general to convey that an item, term, etc. may be either X, Y, or Z. Thus, such conjunctive language is not generally intended to imply that certain embodiments require the presence of at least one of X, at least one of Y, and at least one of Z.

[0166] Language of degree used herein, such as the terms “approximately,” “about,” “generally,” and “substantially” as used herein represent a value, amount, or characteristic close to the stated value, amount, or characteristic that still performs a desired function or achieves a desired result. For example, the terms “approximately”, “about”, “generally,” and “substantially” may refer to an amount that is within less than 10% of, within less than 5% of, within less than 1% of, within less than 0.1% of, and within less than 0.01% of the stated amount. As another example, in certain embodiments, the terms “generally parallel” and “substantially parallel” refer to a value, amount, or characteristic that departs from exactly parallel by less than or equal to 15 degrees, 10 degrees, 5 degrees, 3 degrees, 1 degree, or 0.1 degree.

[0167] The scope of the present disclosure is not intended to be limited by the specific disclosures of preferred embodiments in this section or elsewhere in this specification, and may be defined by claims as presented in this section or elsewhere in this specification or as presented in the future. The language of the claims is to be interpreted broadly based on the language employed in the claims and not limited to the examples described in the present specification or during the prosecution of the application, which examples are to be construed as non-exclusive.

WHAT IS CLAIMED IS:

1. A delivery system for controlled deployment of a replacement valve, the delivery system comprising:

a first member configured to at least partially restrain a first end of the replacement valve;

a second member configured to at least partially restrain a second end of the replacement valve; and

a tether configured to at least partially encircle the replacement valve and radially restrain at least a portion of the replacement valve after the second member has been removed from the second end of the replacement valve but with the first member still at least partially restraining the first end of the replacement valve.

2. The delivery system of Claim 1, wherein the first member comprises a first shaft and the second member comprises a second shaft, the second shaft being positioned over the first shaft and slidable relative to the first shaft.

3. The delivery system of Claim 2, wherein the first member comprises a nose cone configured to receive and cover the first end of the replacement valve, the nose cone being connected to a distal end of the first shaft.

4. The delivery system of Claim 3, wherein the nose cone comprises a proximally-facing opening to receive at least a first end of the replacement valve.

5. The delivery system of Claim 3 or 4, wherein the nose cone comprises a taper towards the distal end of the nose cone.

6. The delivery system of any one of Claims 3-5, wherein an outer diameter of the nose cone is similar to an outer diameter of the second shaft.

7. The delivery system of any one of Claims 3-5, wherein an outer diameter of the nose cone is similar to an inner diameter of the second shaft.

8. The delivery system of any one of Claims 2-7, wherein the first member comprises an inner retention ring configured to engage the first end of the replacement valve, the inner retention ring connected to a distal portion of an inner retention shaft, the inner retention shaft being positioned between the first shaft and the second shaft and being slidable relative to the first shaft.

9. The delivery system of Claim 8, wherein the inner retention ring comprises a taper towards a proximal end of the inner retention ring.

10. The delivery system of Claim 8 or 9, wherein the inner retention ring comprises a cavity at or near a distal end of the inner retention ring and a compressible member received at least partially within the cavity, the compressible member having a compressed diameter and an expanded diameter.

11. The delivery system of any one of Claims 2-10, further comprising a tether retention assembly configured to restrain the tether such that the tether can be tensioned to restrain at least a portion of the replacement valve.

12. The delivery system of Claim 11, wherein the tether retention assembly comprises an inner component and an outer component, the outer component configured to cooperate with the inner component to restrain the tether.

13. The delivery system of Claim 12, wherein the inner component comprises a C-lock.

14. The delivery system of Claim 12 or 13, wherein the outer component comprises a sheath.

15. The delivery system of any one of Claims 12-14, wherein the outer component is moveable relative to the inner component to release the tether.

16. The delivery system of any one of Claims 12-15, wherein the tether retention assembly further comprises a locking shaft, the outer component positioned at or near a distal end of the locking shaft.

17. The delivery system of Claim 16, wherein the locking shaft comprises a radial protrusion configured to maintain radial alignment between the locking shaft and the second shaft.

18. The delivery system of Claim 16 or 17, wherein the locking shaft further comprises a guide member for the tether.

19. The delivery system of any one of Claims 2-18, wherein the second member comprises an outer elongate hollow member configured to cover at least the second end of the replacement valve, the outer elongate hollow member being connected to a distal end of the second shaft.

20. The delivery system of Claim 19, wherein the outer elongate hollow member has a substantially constant diameter throughout the entirety of its length.

21. The delivery system of Claim 19, wherein the diameter of the outer elongate hollow member is substantially similar to a diameter of the second shaft.

22. The delivery system of Claim 21, wherein the outer elongate hollow member is moveable relative to the first member to uncover the second end of the replacement valve while the first end of the replacement valve remains engaged to the first member.

23. The delivery system of Claim 22, further comprising an introducer sheath positioned over the second shaft.

24. The delivery system of any one of Claims 2-23, further comprising a plug, the plug being moveable to engage the first member when the first member is retrieved from a patient.

25. The delivery system of Claim 24, further comprising a plug shaft positioned between the first shaft and the second shaft and slidable relative to the first shaft.

26. The delivery system of any one of Claims 2-25, wherein the first shaft is hollow to receive a guidewire.

27. The delivery system of any one of Claims 2-26, further comprising a replacement valve, wherein:

- a first end of the replacement valve engages the first member; and
- a second end of the replacement valve engages the second member.

28. A delivery system for controlled deployment of a replacement valve, the delivery system comprising:

- a nose cone shaft having a proximal end and a distal end;
- a nose cone connected to the distal end of the nose cone shaft, wherein the nose cone comprises a proximally-facing opening to receive at least a first end of the replacement valve;
- an inner retention shaft having a proximal end and a distal end, the inner retention shaft being slidable over the nose cone shaft;
- an inner retention ring connected to the distal end of the inner retention shaft, the inner retention ring configured to engage the first end of the replacement valve;

a tether retention member on the inner retention shaft;

a locking shaft having a proximal end and a distal end, the locking shaft being slidable over the inner retention shaft, wherein the locking shaft is configured to cooperate with the tether retention member to releasably engage a tether attached to the replacement valve;

an outer elongate hollow member shaft having a proximal end and a distal end, the outer elongate hollow member shaft being slidable over the locking shaft; and

an outer elongate hollow member connected to the distal end of the outer elongate hollow member shaft, the outer elongate hollow member having a proximal end and a distal end, wherein the outer elongate hollow member is configured to cover at least the second end of the replacement valve when the first end of the replacement valve is engaged with the inner retention ring and is covered by the nose cone;

wherein the outer elongate hollow member is moveable relative to the nose cone to uncover the second end of the replacement valve while the first end of the replacement valve remains engaged to the inner retention ring and is covered by the nose cone.

29. The delivery system of Claim 28, wherein the nose cone comprises a taper towards the distal end of the nose cone.

30. The delivery system of Claim 28 or 29, wherein an outer diameter of the nose cone is similar to an outer diameter of at least one of the outer elongate hollow member shaft and the outer elongate hollow member.

31. The delivery system of Claims 28 or 29, wherein an outer diameter of the nose cone is similar to an inner diameter of at least one of the outer elongate hollow member shaft and the outer elongate hollow member.

32. The delivery system according to any one of Claims 28-31, wherein the inner retention ring comprises a taper towards a proximal end of the inner retention ring.

33. The delivery system according to any one of Claims 28-32, wherein the inner retention ring comprises a cavity at or near a distal end of the inner retention ring and a

compressible member received at least partially within the cavity, the compressible member having a compressed diameter and an expanded diameter.

34. The delivery system of Claim 33, wherein the compressed diameter is approximately equal to an inner diameter of the nose cone and the expanded diameter is greater than the inner diameter of the nose cone.

35. The delivery system according to any one of Claims 28-34, wherein the locking shaft comprises a radial protrusion configured to maintain radial alignment between the locking shaft and the outer elongate hollow member shaft.

36. The delivery system according to any one of Claims 28-35, wherein the locking shaft comprises a guide member for the tether.

37. The delivery system according to any one of Claims 28-36, wherein the outer elongate hollow member has a substantially constant diameter throughout the entirety of its length.

38. The delivery system according to any one of Claims 28-37, wherein the diameter of the outer elongate hollow member is substantially similar to a diameter of the outer elongate hollow member shaft.

39. The delivery system according to any one of Claims 28-38, further comprising an introducer sheath having a proximal end and a distal end slidable over the outer elongate hollow member shaft.

40. The delivery system according to any one of Claims 28-39, wherein the tether retention member comprises a C-lock.

41. The delivery system of Claim 40, further comprising a lock at the distal end of the locking shaft to cover the C-lock to releasably retain a tether therein.

42. The delivery system of any one of Claims 28-41, further comprising a plug shaft having a proximal end and a distal end, the plug shaft being slidable over the locking shaft and the outer elongate hollow member shaft being slidable over the plug shaft, and further comprising a plug at the distal end of the plug shaft to engage the nose cone when the nose cone is retrieved from a patient.

43. The delivery system of any one of the Claims 28-42, wherein the nose cone shaft is hollow to receive a guidewire.

44. The delivery system of any one of Claims 28-43, further comprising a replacement valve, wherein:

a first end of the replacement valve engages the inner retention ring and is covered by the nose cone;

a second end of the replacement valve is covered by the outer elongate hollow member shaft; and

a tether is connected to the tether retention member, the tether retention member being covered by a lock at the distal end of the locking shaft, the tether wrapping at least partially around the replacement valve and then extending proximally through at least the outer elongate hollow member shaft.

45. A method of delivering an intraluminal frame assembly to intraluminal tissue at an in situ target location, the method comprising:

delivering an intraluminal frame assembly to the in situ target location while the frame assembly is in a radially compacted state within an outer member, the frame assembly comprising a frame having a first end, a second end and a longitudinal axis extending between the first and second ends, the frame further comprising a tether encircling at least a portion of the frame, the tether configured to restrain the radial dimension of the frame;

at least partially removing the outer member from the frame assembly, wherein the tether restrains the radial dimension of the frame after the outer member is at least partially removed; and

releasing the tether from the frame to allow at least a portion of the frame assembly to radially expand.

46. The method of Claim 45, wherein releasing the tether from the frame allows the second end of the frame to radially expand while the first end of the frame remains radially restrained.

47. The method of Claim 46, further comprising radially expanding the first end of the frame after releasing the tether to allow the second end of the frame to radially expand.

48. The method of Claim 47, wherein the first end of the frame, prior to radial expansion, is restrained by a nose cone covering at least the first end of the frame.

49. The method of Claim 48, wherein the outer member is at least partially removed from the frame assembly by moving the outer member relatively away from the nose cone.

50. The method of Claim 49, wherein the outer member is at least partially removed in a proximal direction from the frame assembly by moving the outer member relatively away from the nose cone.

51. The method of Claim 50, wherein the intraluminal frame assembly comprises a plurality of anchors at its second end, wherein the plurality of anchors extend proximally away from the second end of the frame assembly as the outer member is moved proximally, and the plurality of anchors flip to extend distally away from the second end of the frame assembly after the outer member uncovers the plurality of anchors, and wherein the tether radially restrains the frame assembly during flipping of the anchors.

52. The method of any one of Claims 45-51, wherein the intraluminal frame assembly comprises a replacement heart valve.

53. The method of any one of Claims 45-52, wherein the intraluminal frame assembly is delivered transapically to a mitral valve location.

54. A delivery system for controlled deployment of a replacement valve, the delivery system comprising:

a delivery catheter;

a radially compacted replacement valve having a longitudinal axis positioned within the delivery catheter and comprising a plurality of first anchors wherein the first anchors each have an end pointing in a first longitudinal direction in the radially compacted state and the end is configured to change direction to point in a second longitudinal direction, the ends pointing in the second longitudinal direction after the replacement valve is deployed from the delivery catheter;

a cover positioned over the plurality of first anchors while the first anchors move from pointing in the first longitudinal direction to the second longitudinal direction, thereby preventing or limiting contact between the first anchors and tissue.

55. A delivery system for controlled deployment of a replacement valve, the delivery system comprising:

a sheath configured to surround a radially compacted replacement valve, wherein retraction of the sheath from off of the radially compacted replacement valve allows the radially compacted replacement valve to at least partially expand;

an expandable cover advanceable over the sheath prior to retraction to allow for expansion of the replacement valve within the expandable cover as the sheath is retracted to prevent or limit contact between the expanding replacement valve and tissue.

56. The delivery system of Claim 55, further comprising the replacement valve, the replacement valve comprising a plurality of anchors that are configured to change direction during expansion.

57. The delivery system of Claim 56, wherein each of the anchors having an end, the end pointing in a first direction prior to expansion and in a second direction after at least partial expansion.

58. The delivery system of Claim 57, wherein each anchor rotates at least 45 degrees during the partial expansion.

59. A method of delivery of a replacement valve, the method comprising:

advancing a delivery system holding a radially compacted replacement valve to a native valve, the delivery system comprising:

a sheath surrounding the radially compacted replacement valve; and
an expandable cover;

withdrawing the sheath to allow the replacement valve to at least partially expand within the expandable cover to prevent or limit contact between the expanding replacement valve and tissue.

60. The method of Claim 59, wherein advancing further comprises advancing the delivery system to the native valve transapically.

61. The method of Claim 59 or 60, further comprising advancing the expandable cover over the sheath.

62. A method of delivery of a replacement valve, the method comprising:

advancing a delivery system holding a radially compacted replacement valve to a native valve, the delivery system having a longitudinal axis;

at least partially expanding the replacement valve radially outward from the longitudinal axis and within an expandable cover to prevent or limit contact between the expanding replacement valve and tissue.

63. The method of Claim 62, wherein at least partially expanding the replacement valve comprises allowing a plurality of anchors to self-expand within the expandable cover.

64. The method of Claim 63, wherein allowing the plurality of anchors to self-expand comprises flipping an end of each of the anchors of the plurality of anchors to change a longitudinal orientation of the end from a first longitudinal direction to a second opposite longitudinal direction.

65. A flexible delivery system for controlled deployment with stretch and compression resistance for replacement mitral valve implantation, the delivery system comprising:

an elongate inner member comprising a proximal end and a distal end;

an inner retention mechanism on the elongate inner member, the inner retention mechanism configured to engage a radially compacted proximal end of a replacement mitral valve;

a mid shaft assembly configured to be slidable over the elongate inner member and the inner retention mechanism, the mid shaft assembly comprising:

an outer retention member configured to cover at least the radially compacted proximal end of the replacement mitral valve when the proximal end of the replacement mitral valve is engaged with the inner retention mechanism;

a first member having a distal end connected to the outer retention member; and

a second member having a distal end connected to the outer retention member and extending along the length of the first member;

an outer sheath configured to be slidable over the mid shaft assembly and configured to cover the distal end of the replacement mitral valve; and

a handle, the first member and second member positioned between the handle and the outer retention member;

wherein the delivery system is configured to retain at least the radially compacted proximal end of the replacement mitral valve between the inner retention mechanism and the outer retention member during advancement of the delivery system within the body and the first and second members facilitate advancement with stretch and compression resistance through long and tortuous pathways.

66. The delivery system of Claim 65, wherein the first member comprises a compression member.

67. The delivery system of Claim 65, wherein the first member comprises a coiled spring.

68. The delivery system of any one of Claims 65-68, wherein the second member comprises a tension member.

69. The delivery system of any one of Claims 65-68, wherein the second member comprises a braided wire.

70. The delivery system of any one of Claims 65-69, wherein the elongate inner member comprises a tube having a lumen sized and configured to slidably accommodate a guidewire.

71. The delivery system of any one of Claims 65-70, further comprising a nose cone connected to the distal end of the elongate inner member.

72. The delivery system of any one of Claims 65-71, wherein the inner retention mechanism comprises a ring comprising a plurality of teeth configured to engage tabs on the proximal end of the replacement mitral valve.

73. The delivery system of any one of Claims 65-72, wherein the outer retention member is a ring.

74. The delivery system of any one of Claims 65-73, further comprising a replacement mitral valve having a proximal end and a distal end.

75. The delivery system of Claim 74, wherein the proximal end of the replacement mitral valve is engaged with the inner retention mechanism on the elongate inner member and is covered by the outer retention member; and the distal end of the replacement mitral valve is covered by the outer sheath.

76. The delivery system of any one of Claims 65-75, wherein the outer sheath comprises a slotted hypo tube.

77. The delivery system of any one of Claims 65-76, wherein at least a segment of the outer sheath is formed of ePTFE.

78. The delivery system of any one of Claims 65-77, wherein mid shaft assembly further comprises a plastic tube, wherein both the compression member and the tension member are connected to the plastic tube and the plastic tube is positioned between the handle and the compression and tension members.

79. A delivery system for an expandable prosthesis, the delivery system comprising:

an elongate inner member comprising a proximal end and a distal end; and
a shaft assembly configured to be slidable over the elongate inner member and at least partially radially constrain an expandable prosthesis when the expandable prosthesis is provided over the elongate inner member, the shaft assembly comprising a compression member and a tension member concentrically arranged.

80. The delivery system of Claim 79, wherein the compression member surrounds the tension member.

81. The delivery system of Claim 79 or 80, further comprising an outer sheath configured to be slidable over the shaft assembly and configured to cover a distal end of the expandable prosthesis when the expandable prosthesis is provided over the elongate inner member.

82. The delivery system of Claim 81, wherein the outer sheath comprises a slotted hypo tube.

83. The delivery system of Claim 82, wherein the slotted hypo tube is configured to surround the compression member and the tension member when the outer sheath covers the distal end of the expandable prosthesis.

84. A method of delivering an expandable prosthesis comprising using the delivery system of any Claims 65-83.

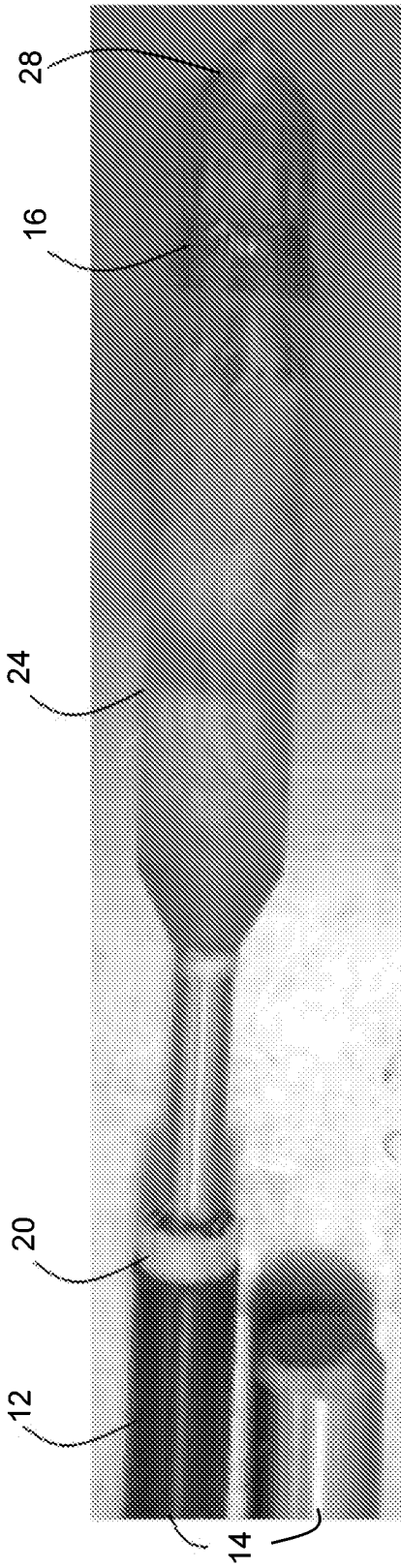

FIG. 1A

10

10

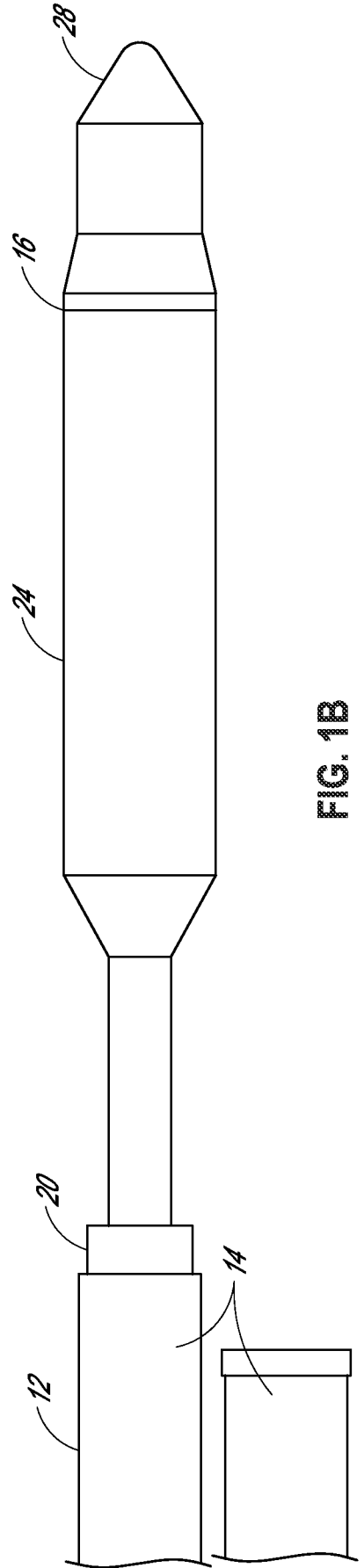

FIG. 1B

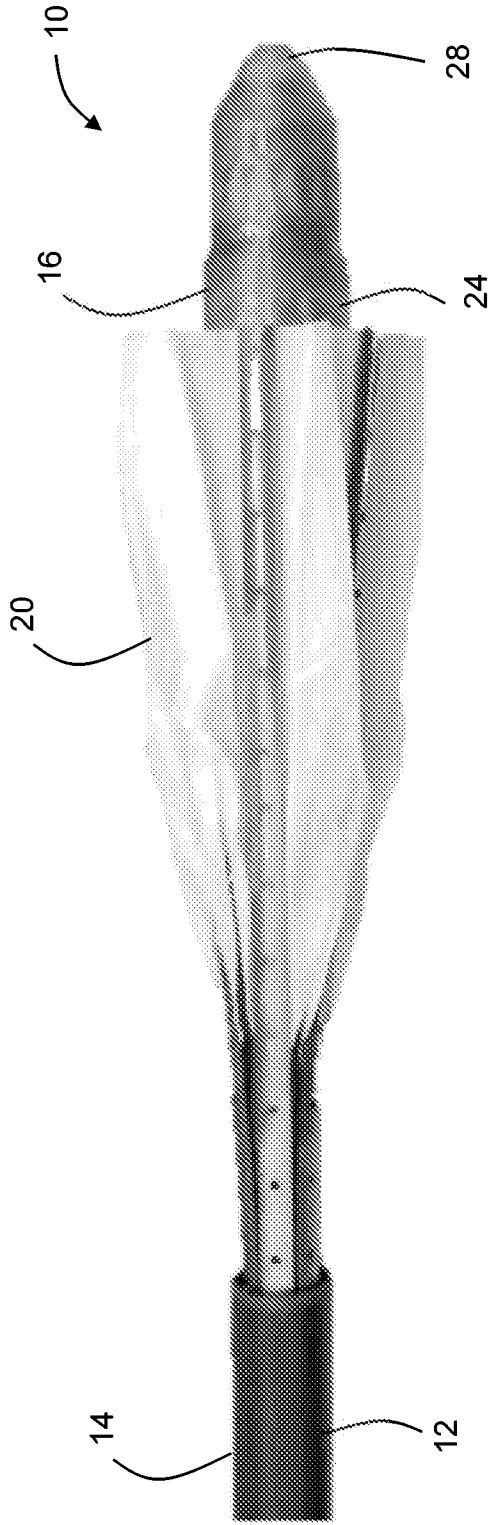

FIG. 2A

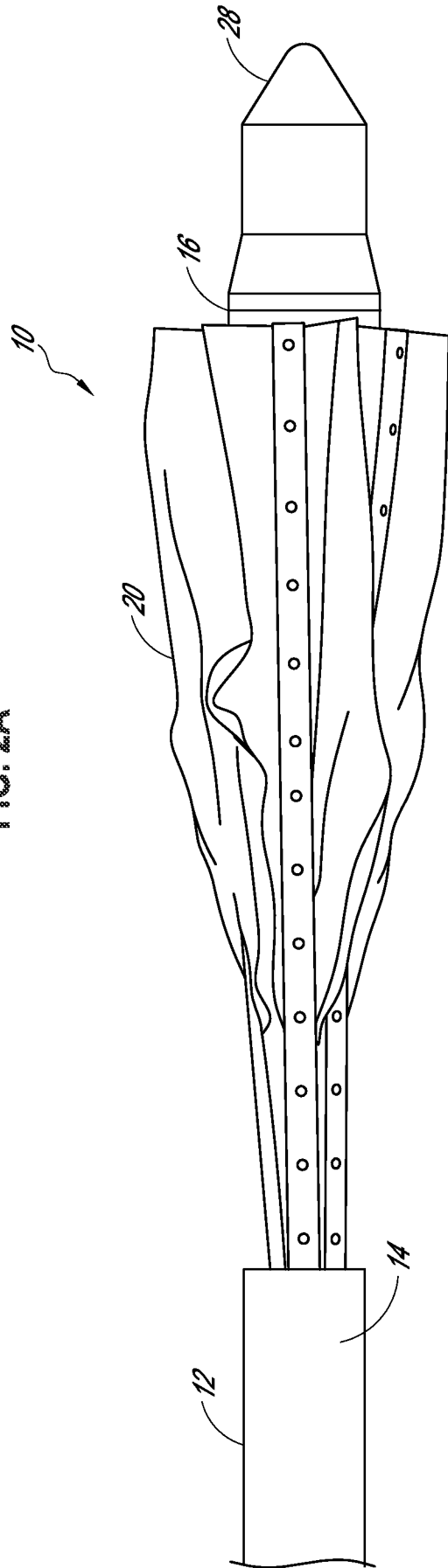

FIG. 2B

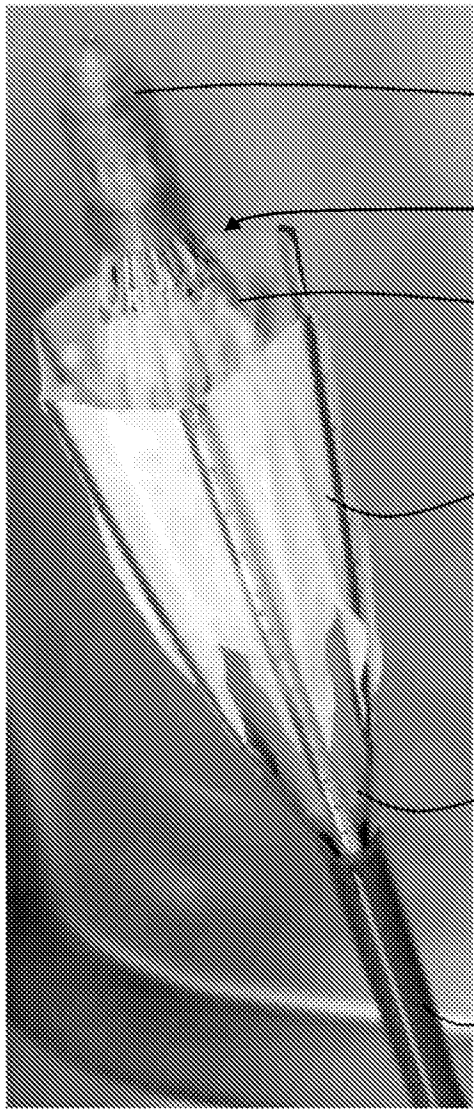

FIG. 3A

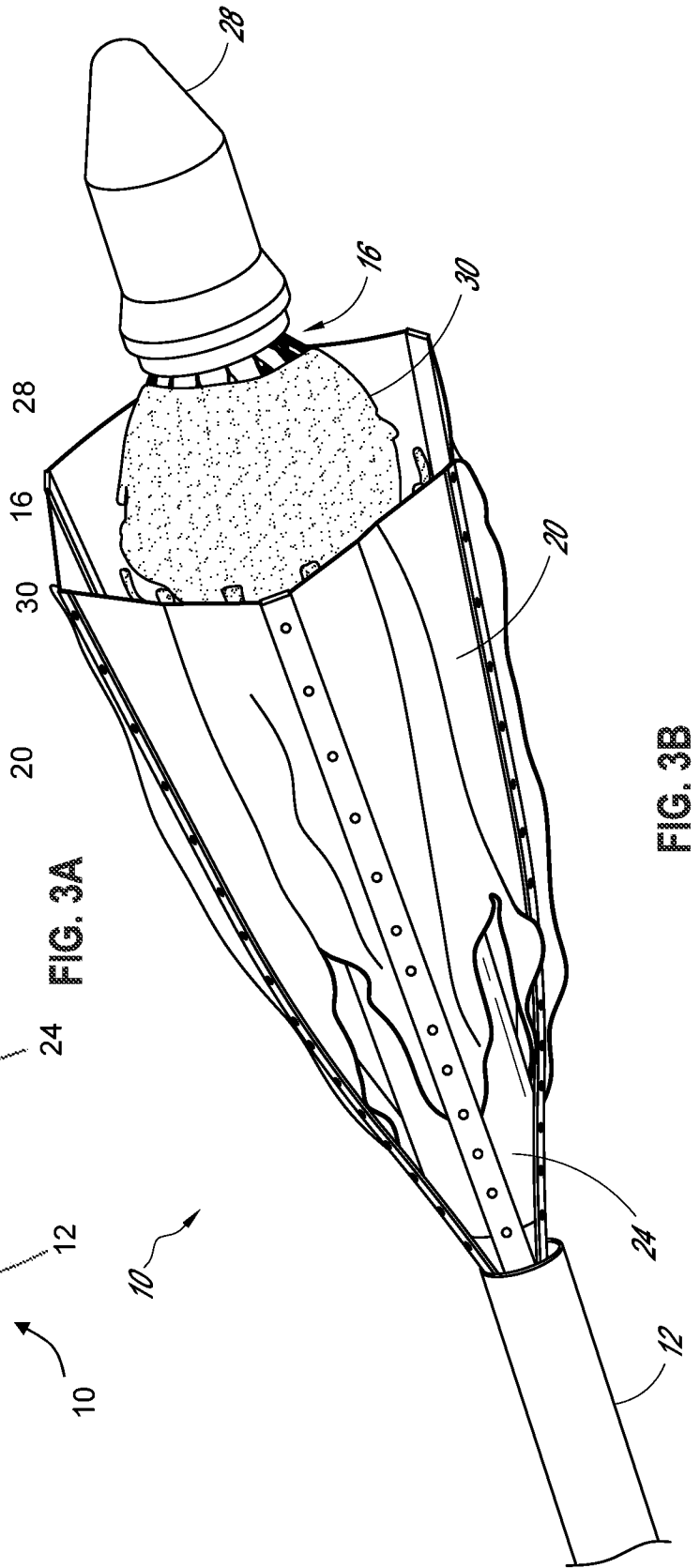
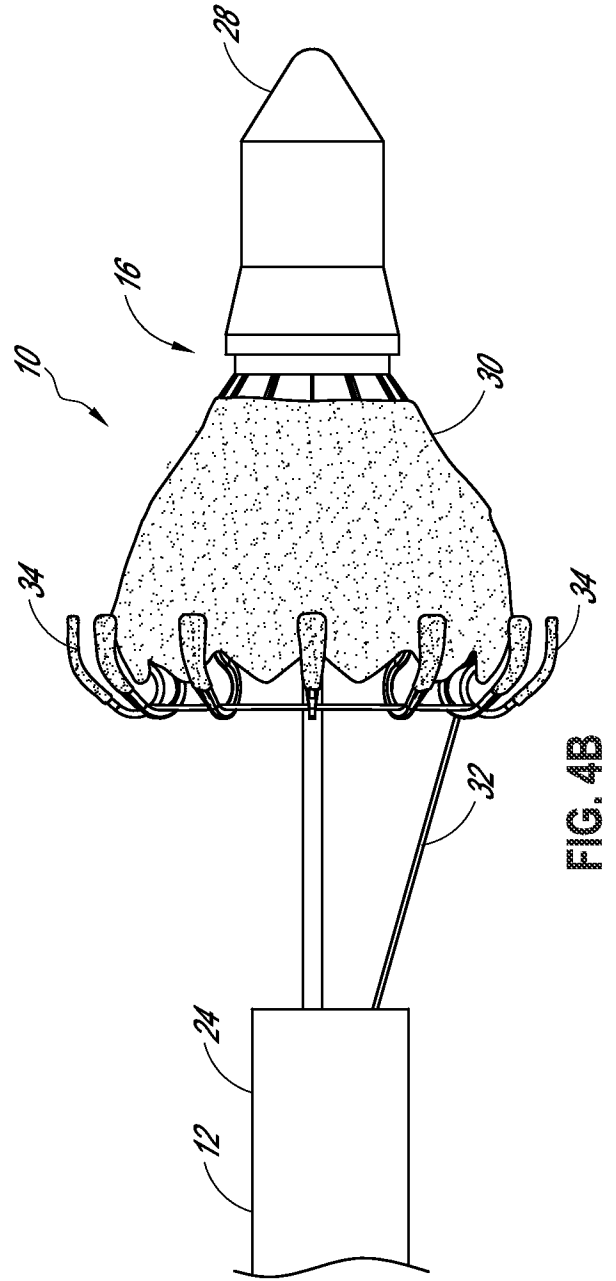
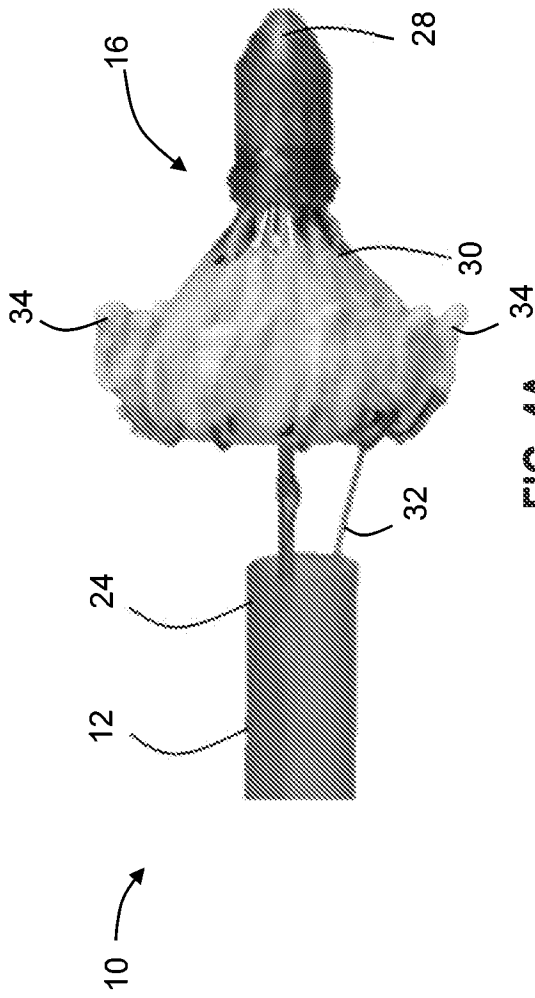

FIG. 3B



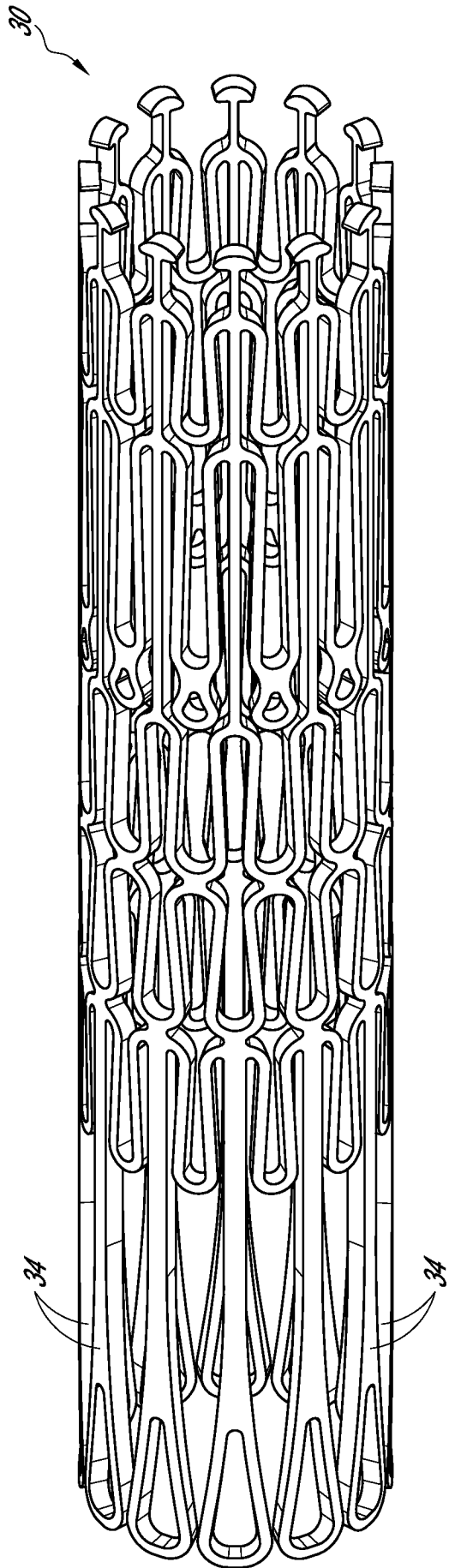

FIG. 5

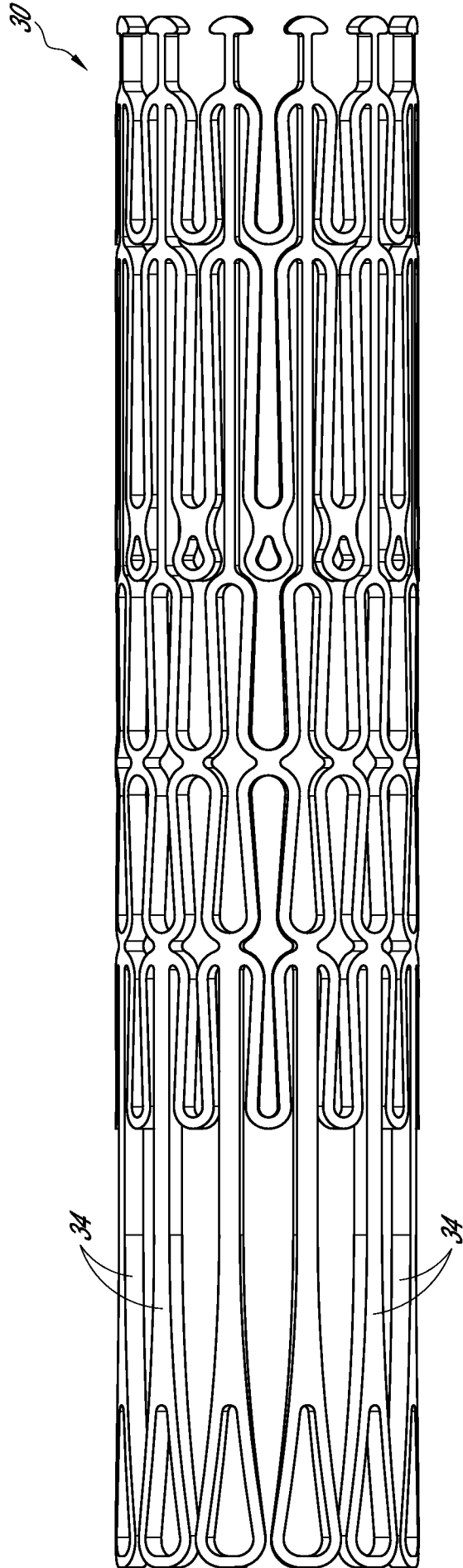

FIG. 6

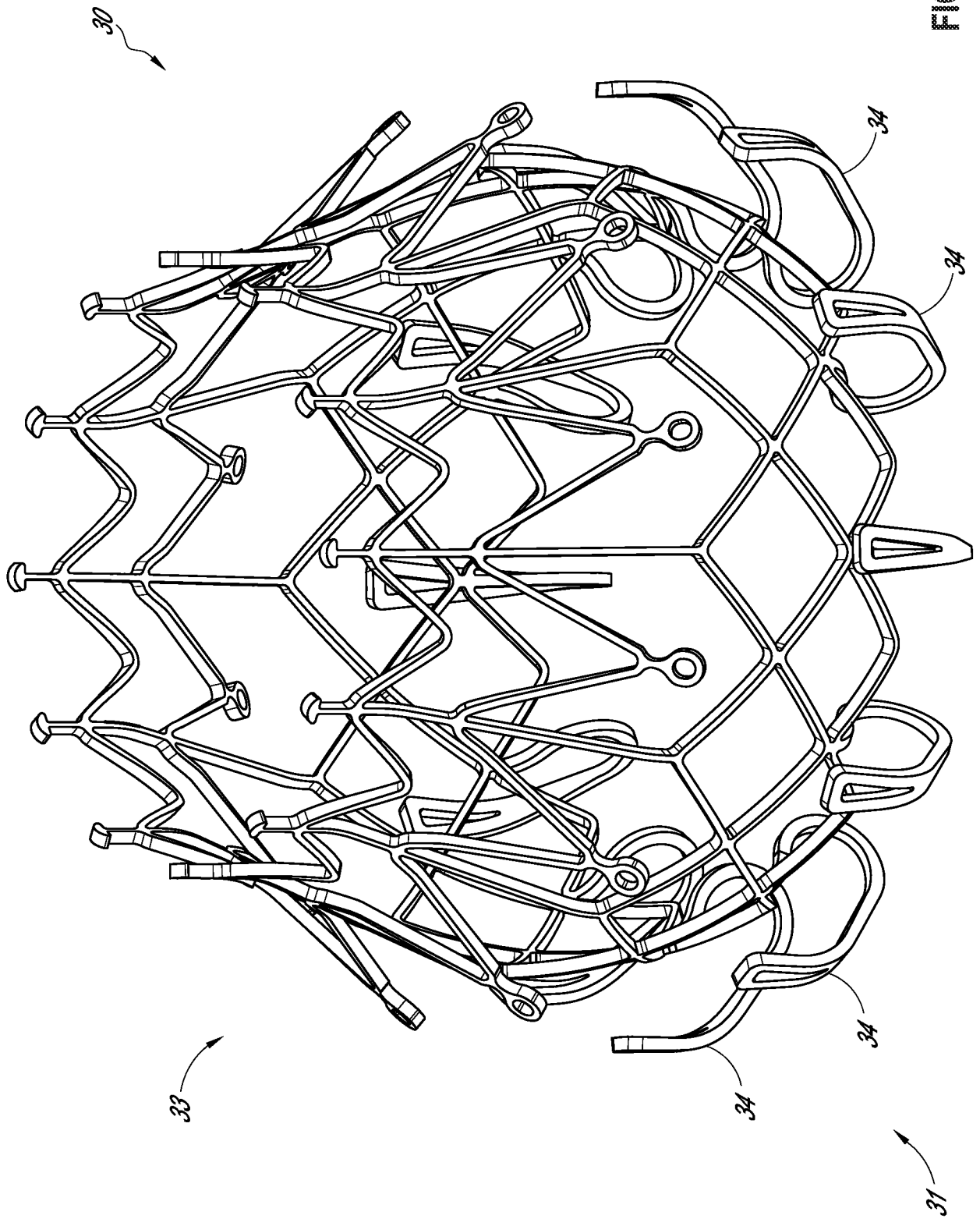

FIG. 7

7/46

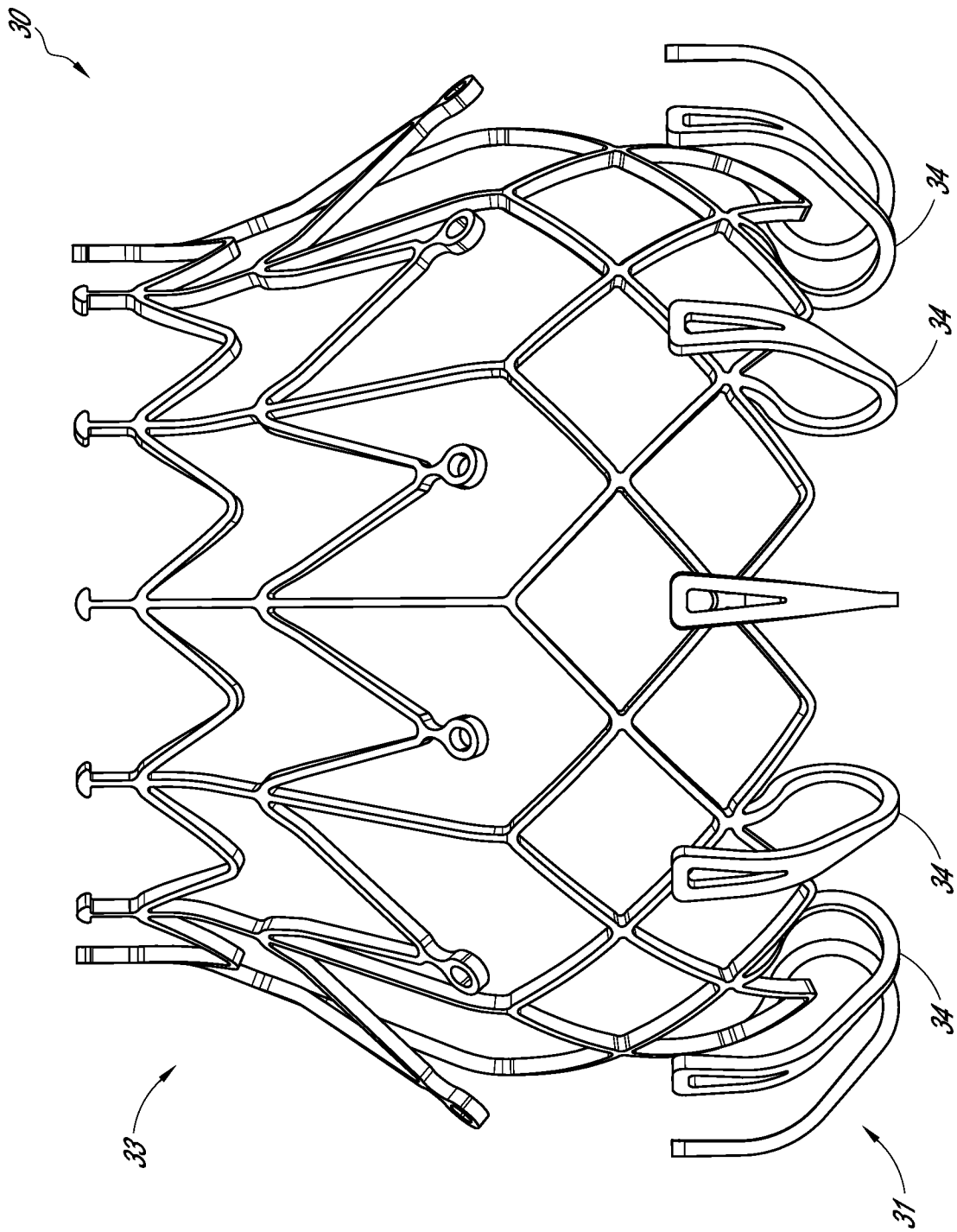

FIG. 8

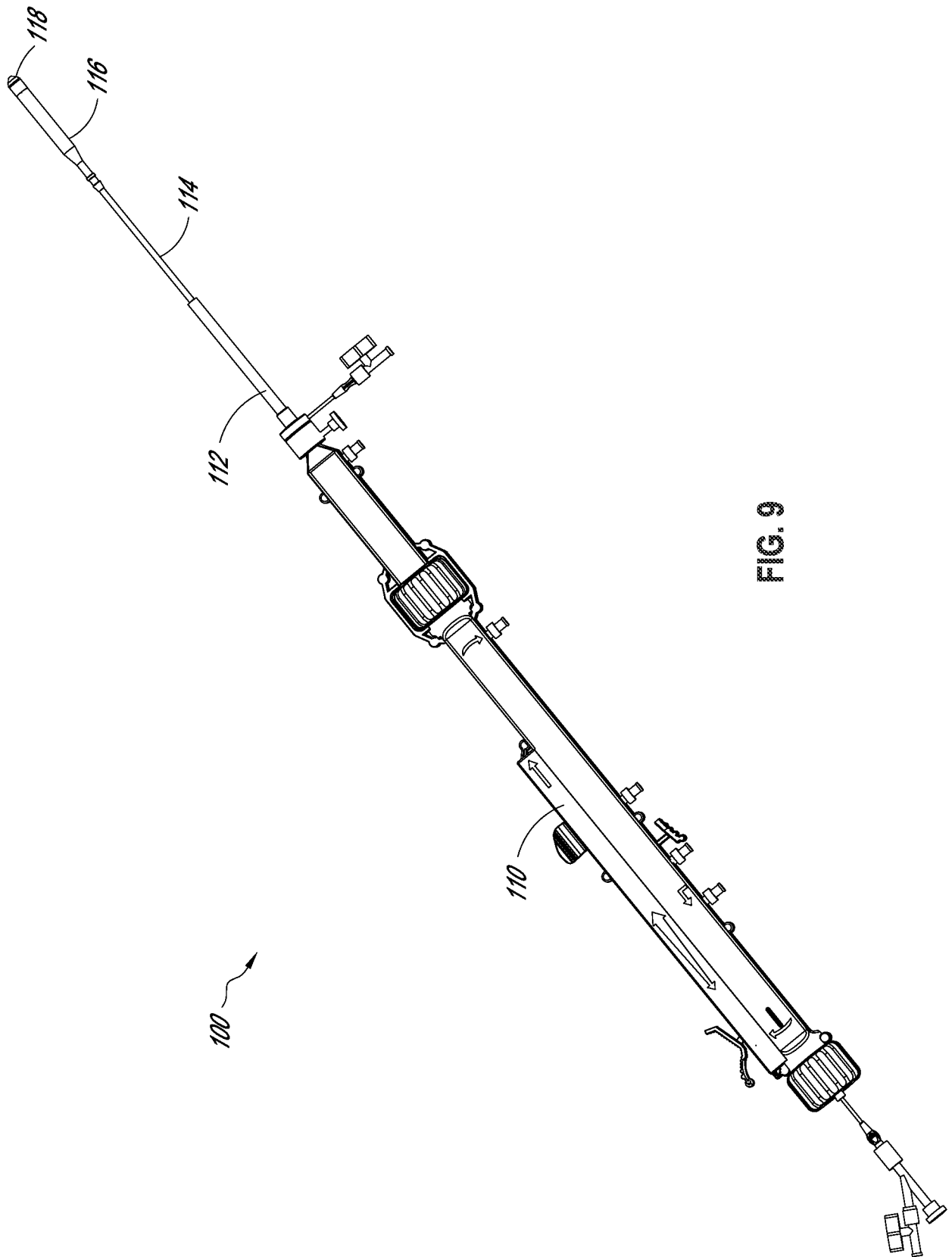

FIG. 9

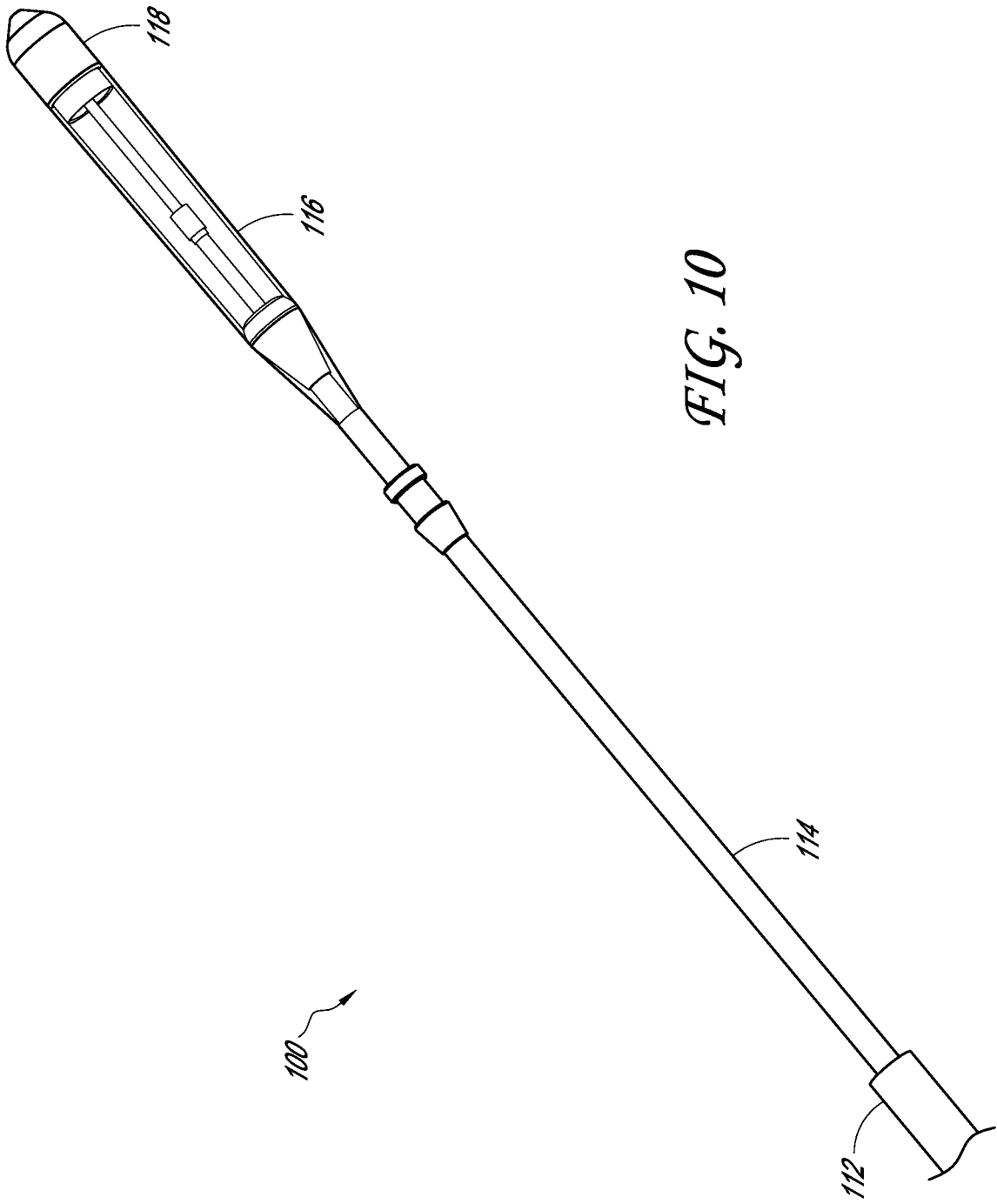
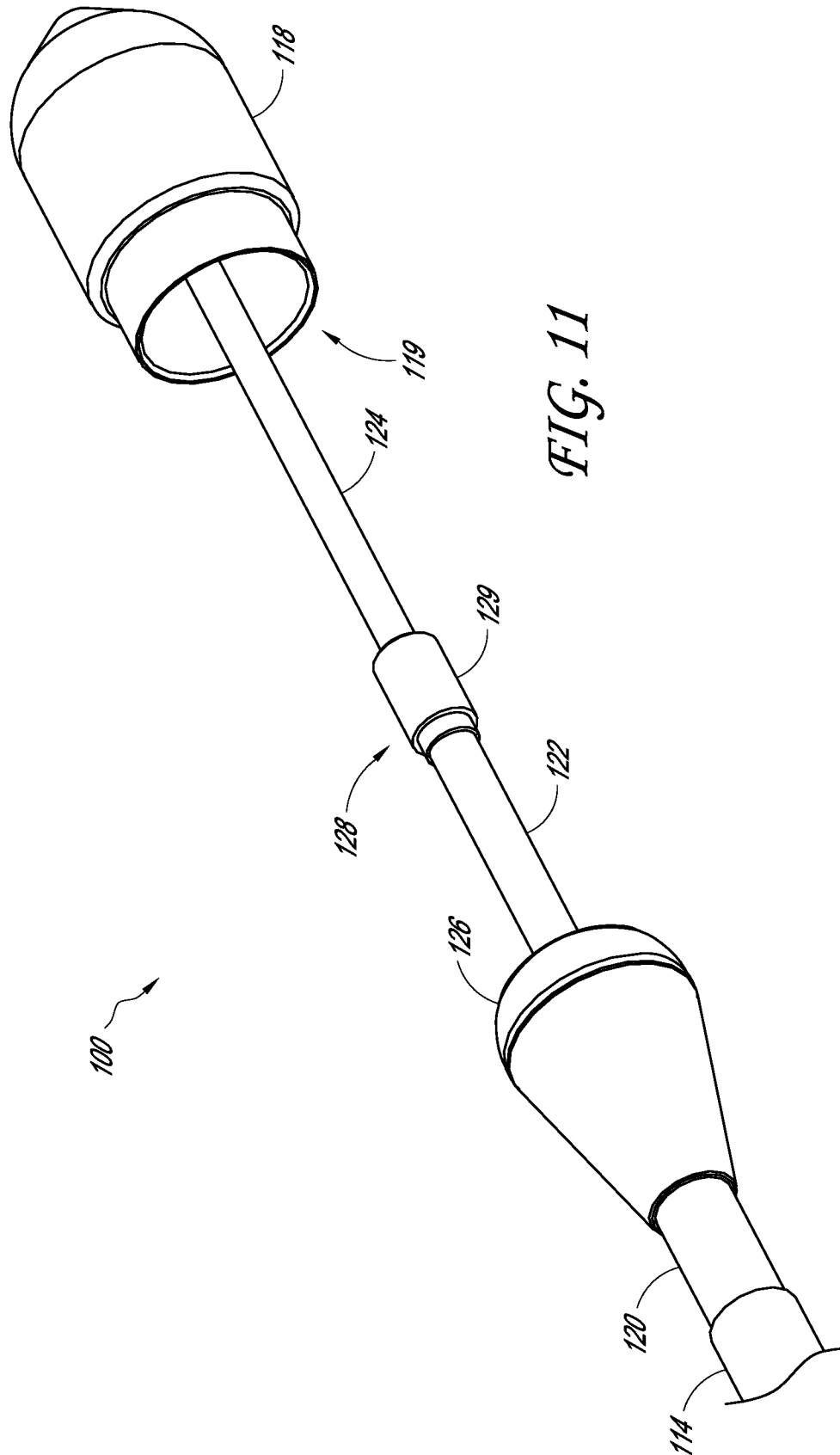

FIG. 10



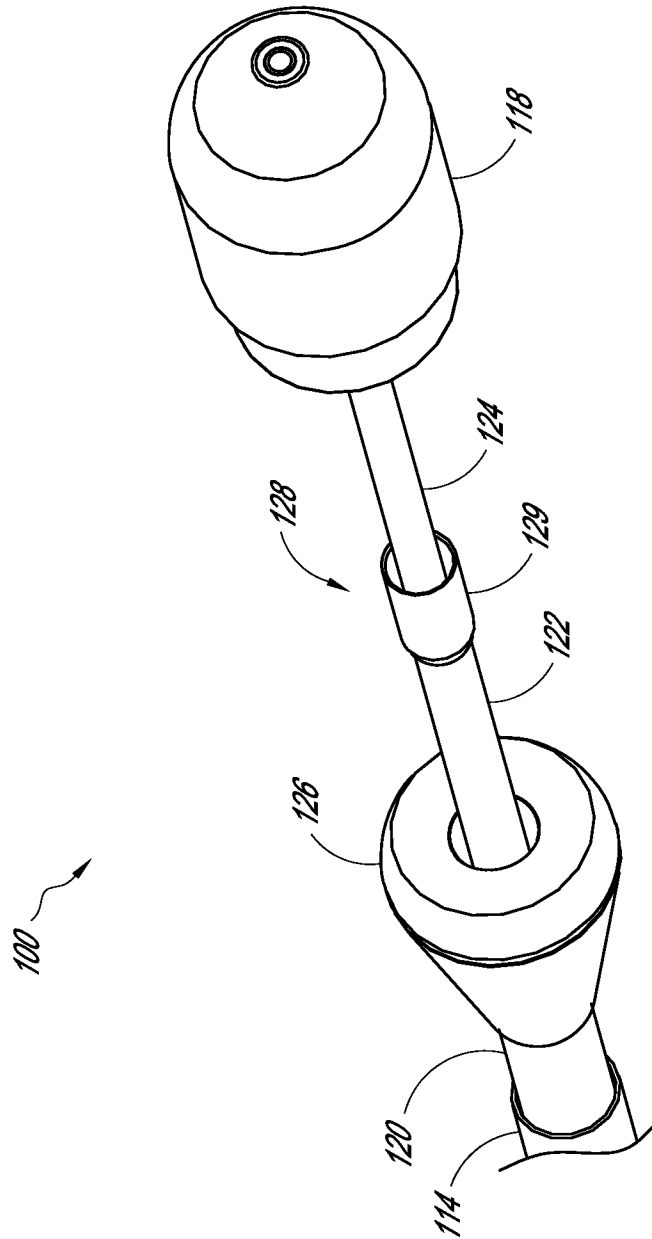
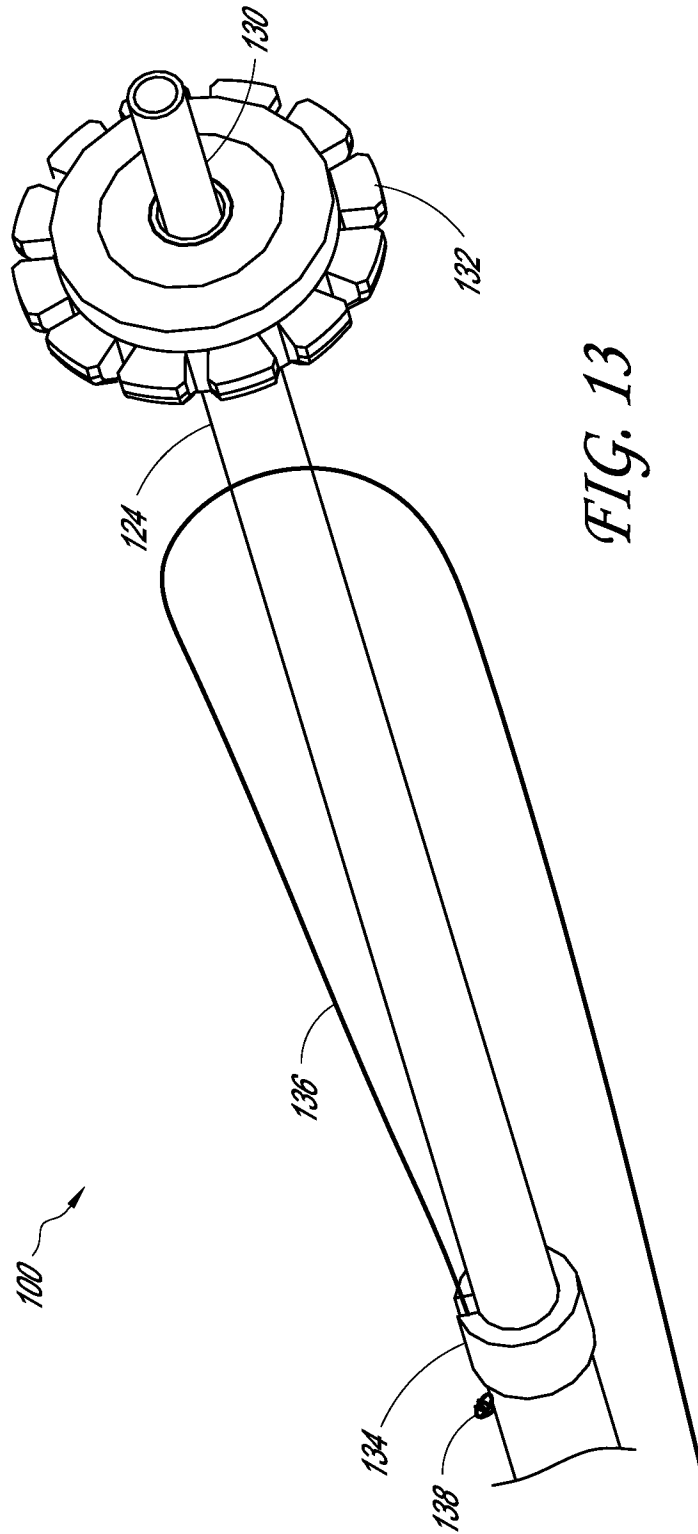

FIG. 12



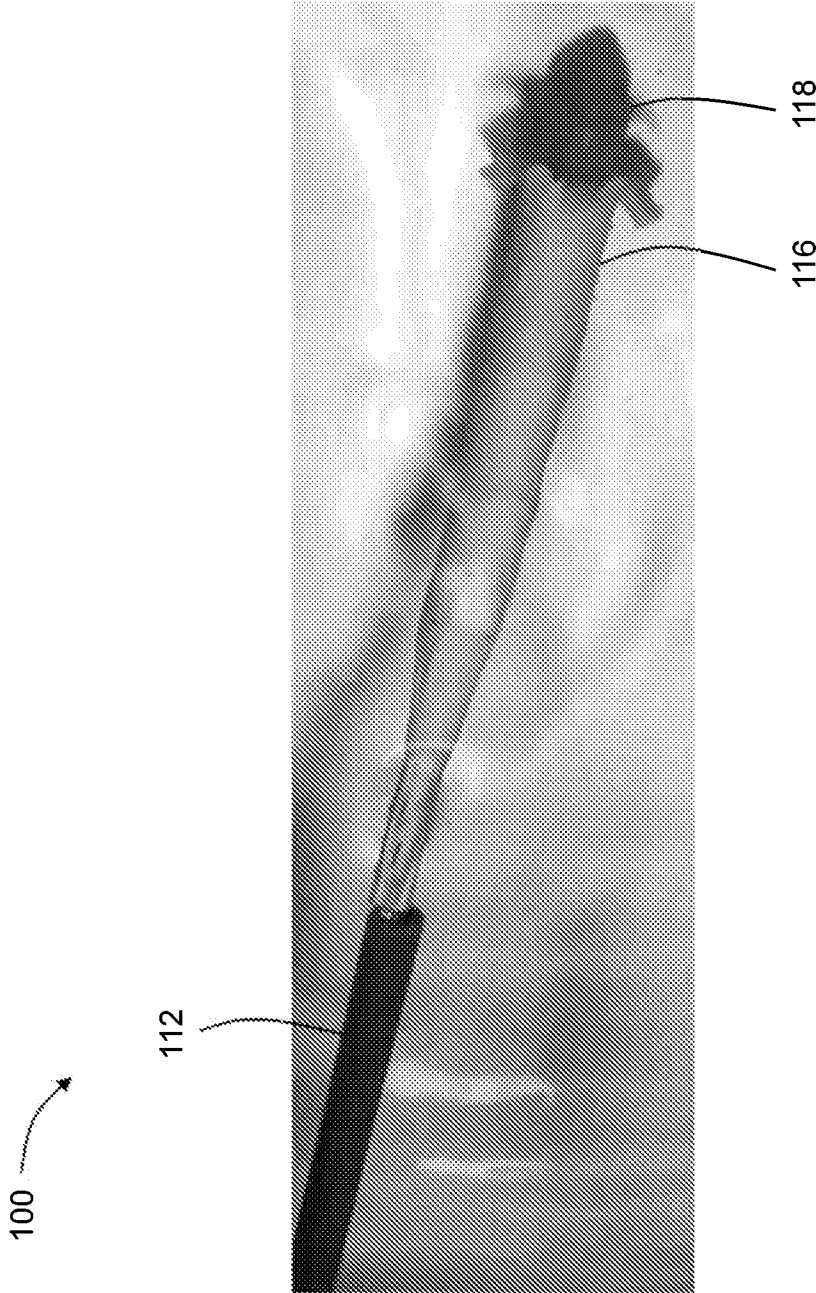

FIG. 14A

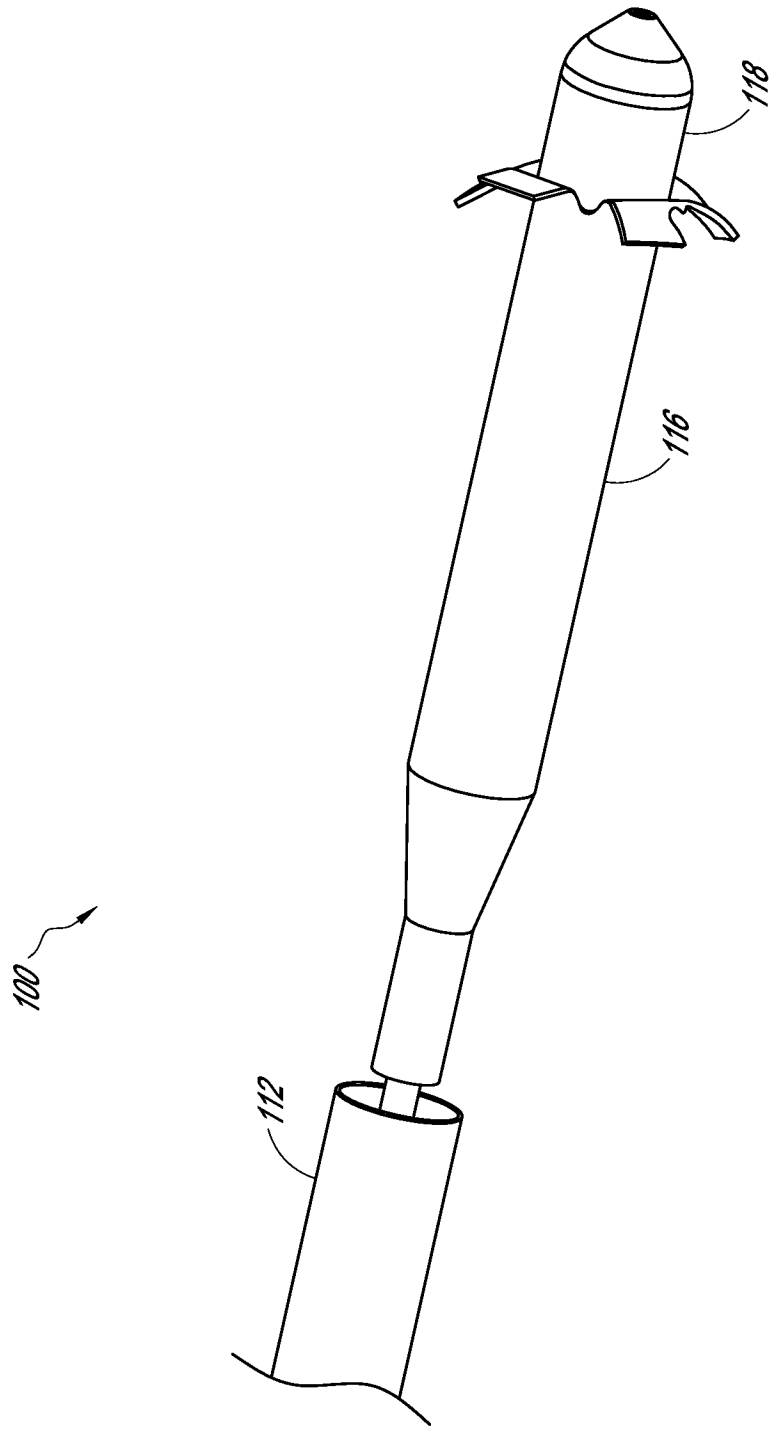

FIG. 14B

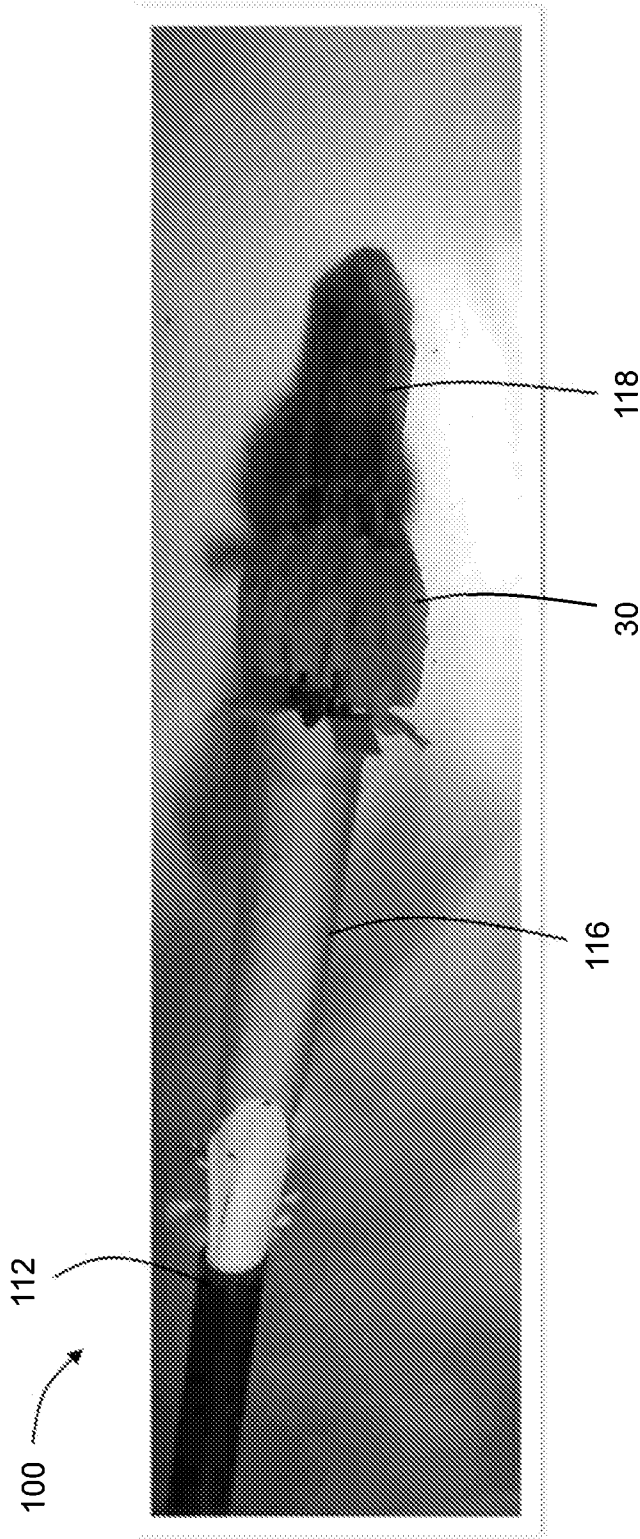

FIG. 15A

16/46

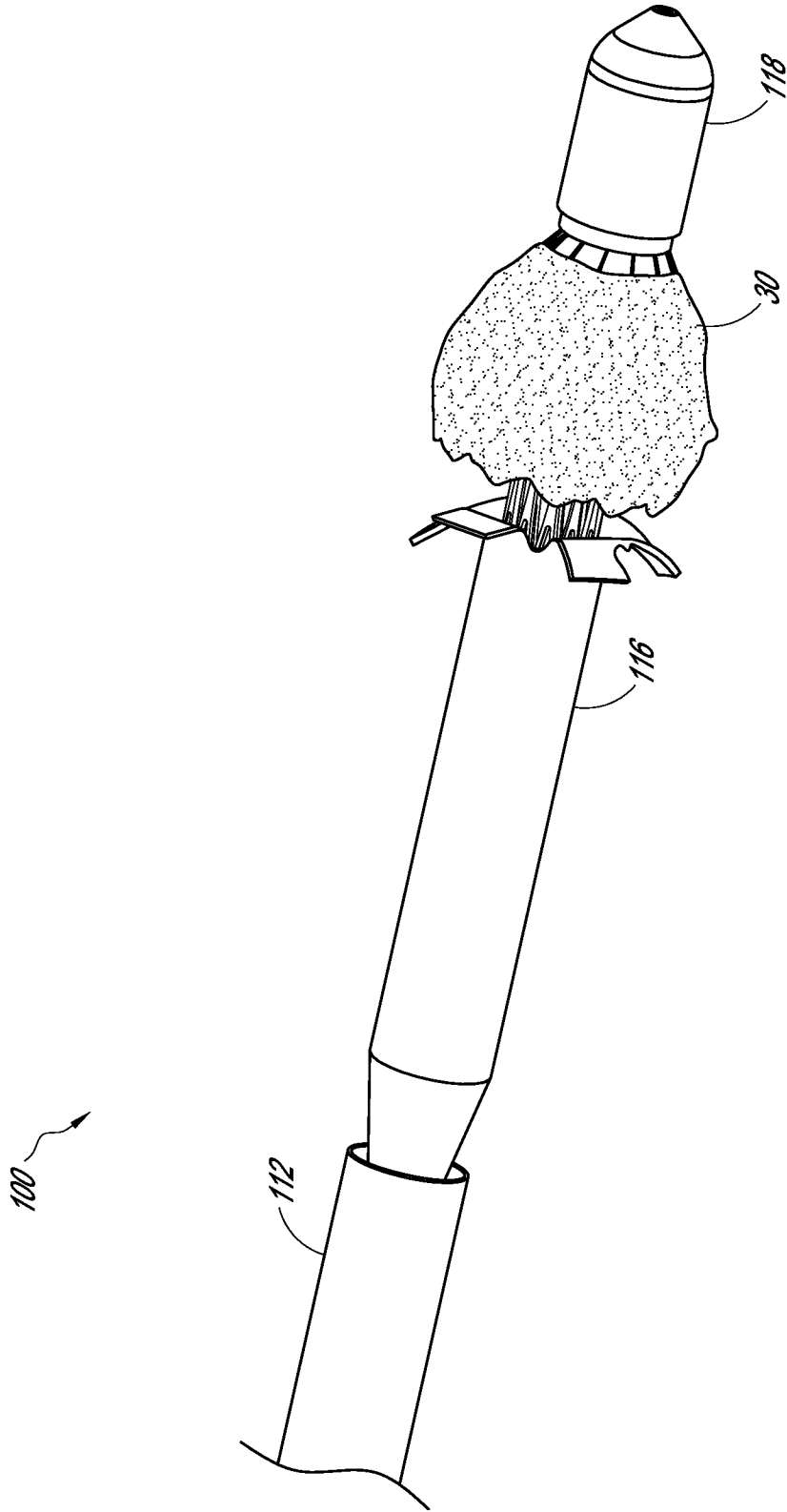

FIG. 15B

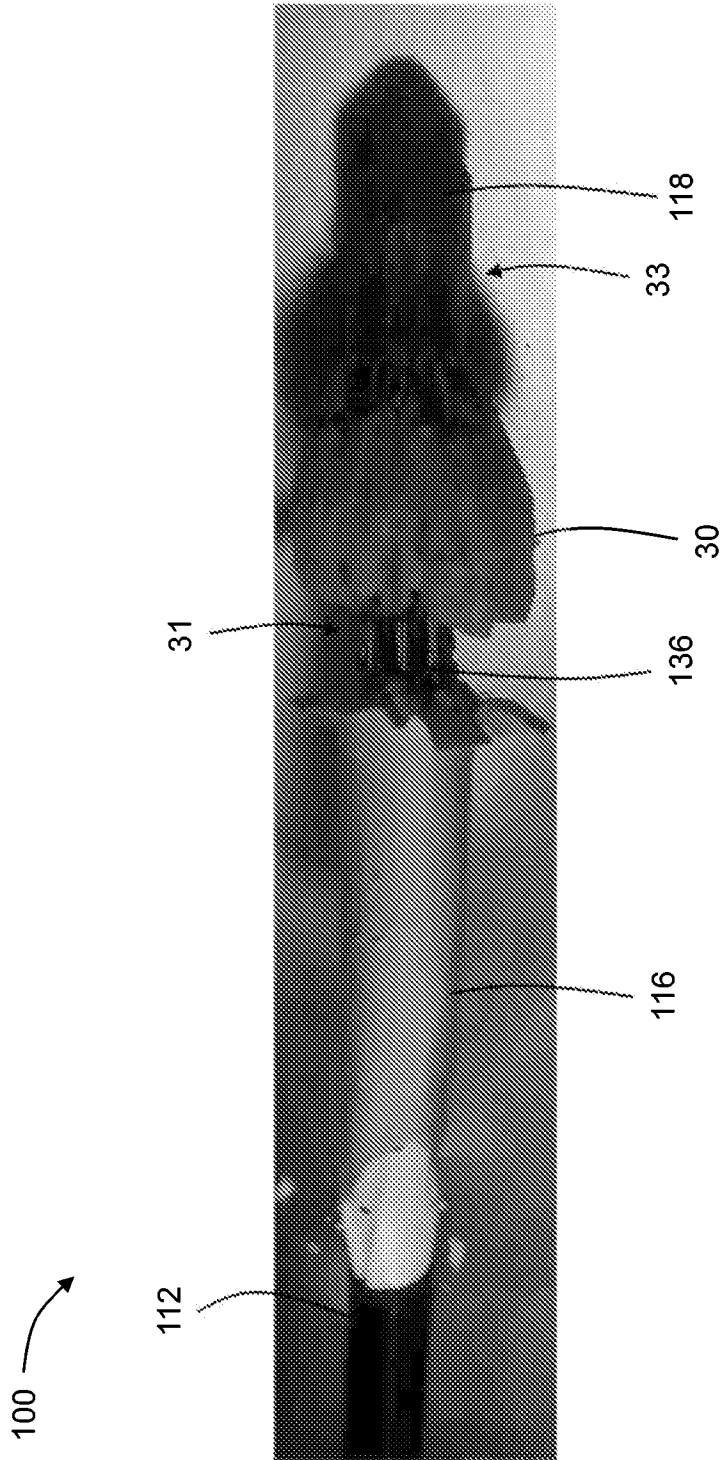

FIG. 16A

18/46

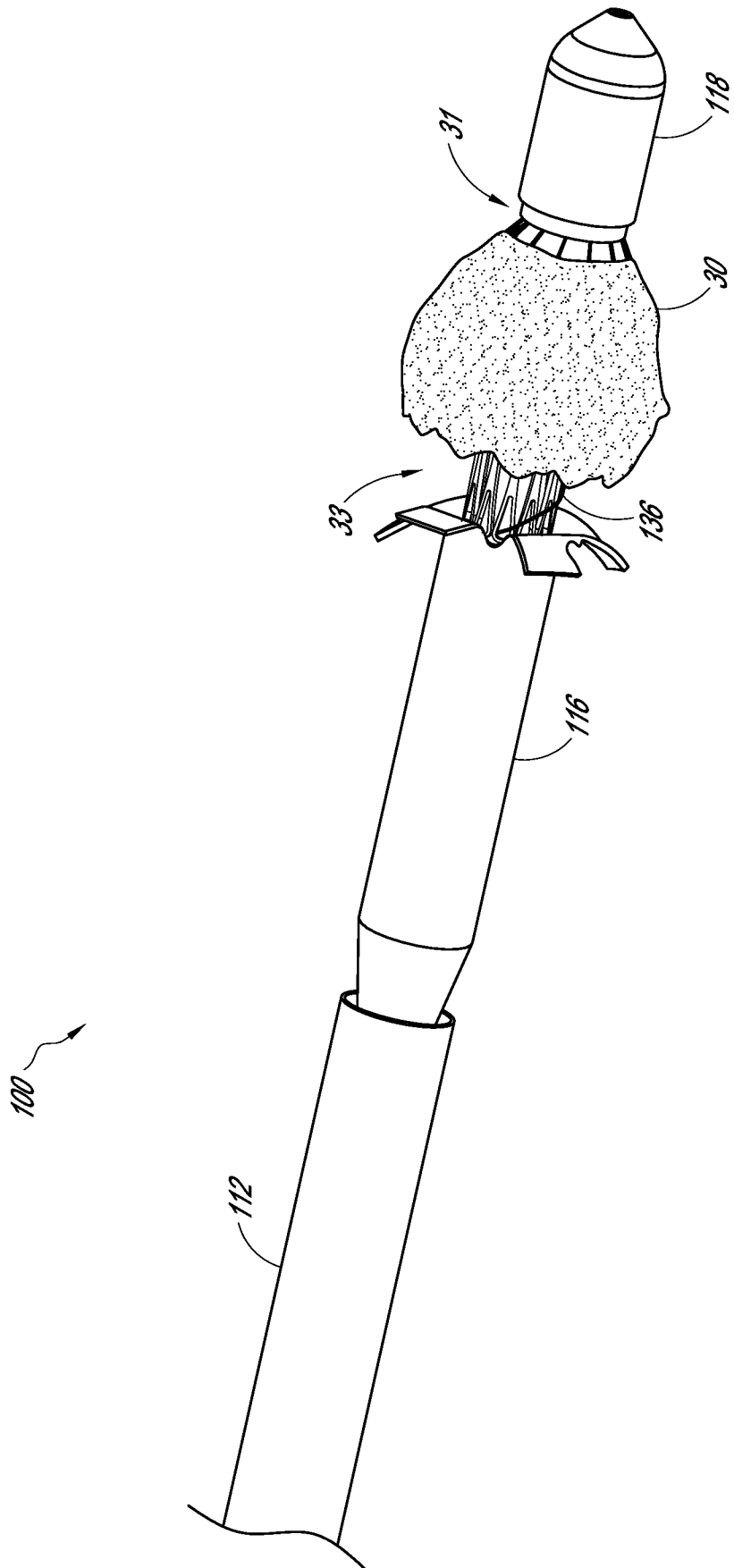

FIG. 16B

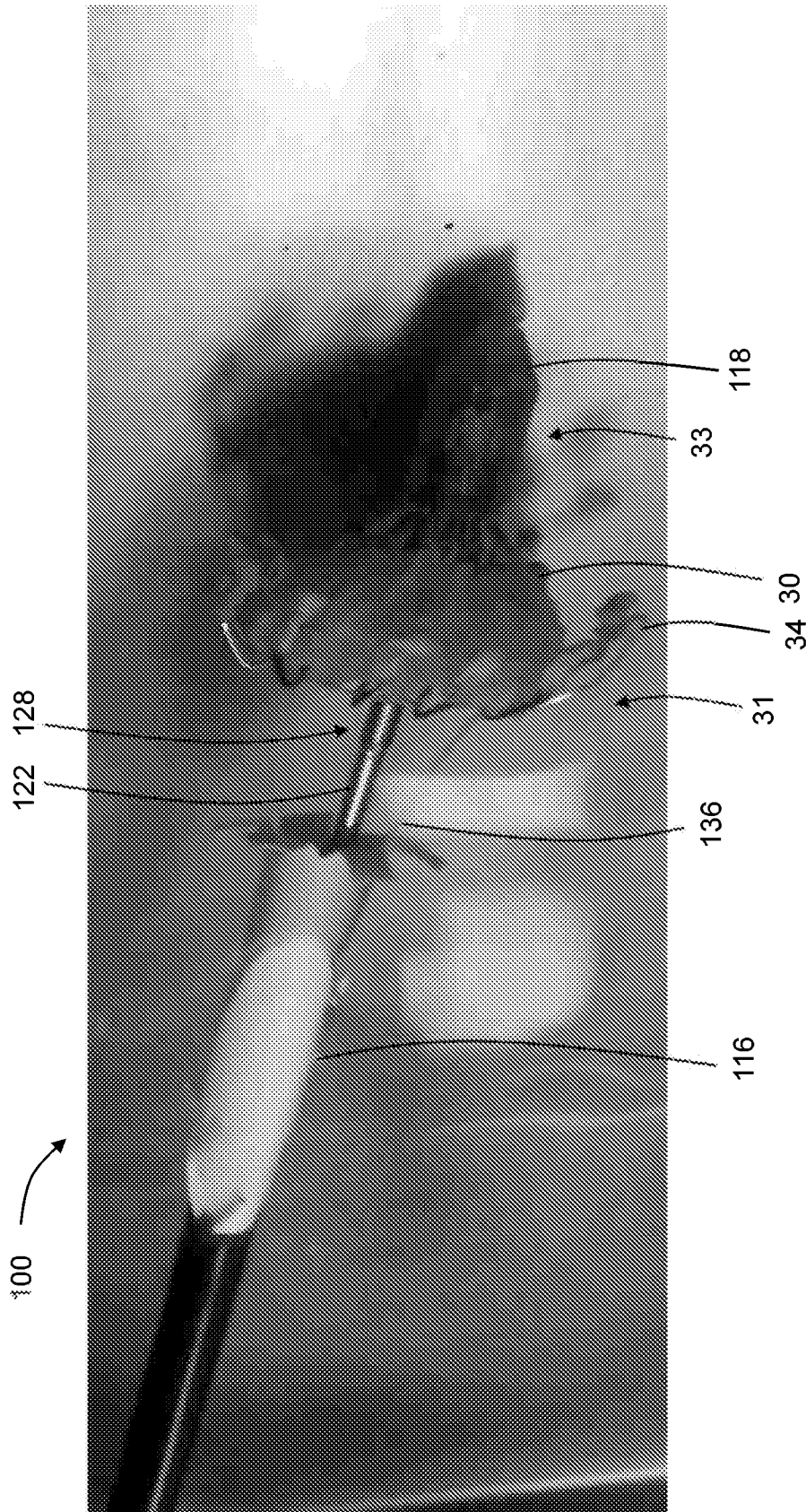
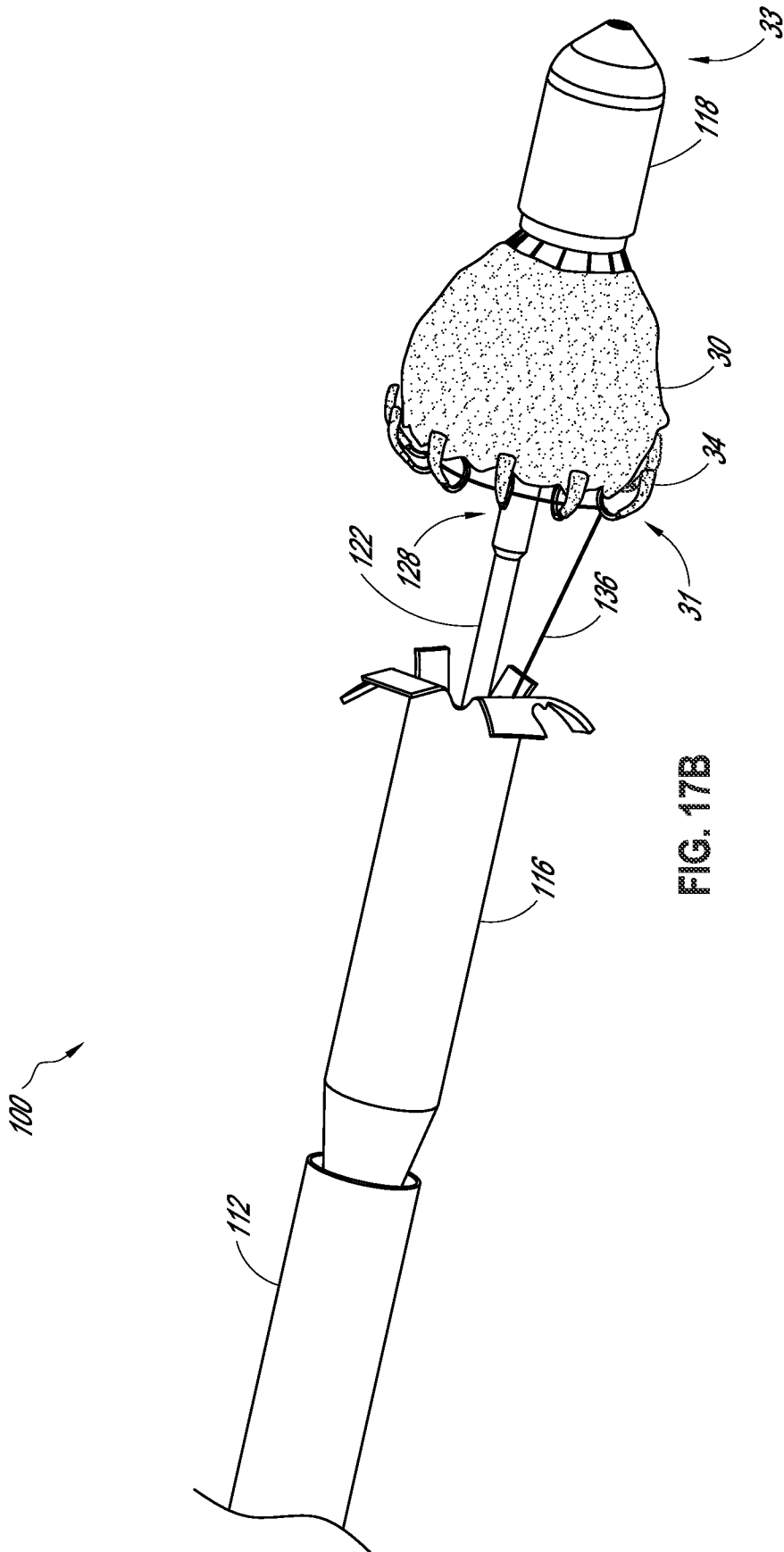

FIG. 17A



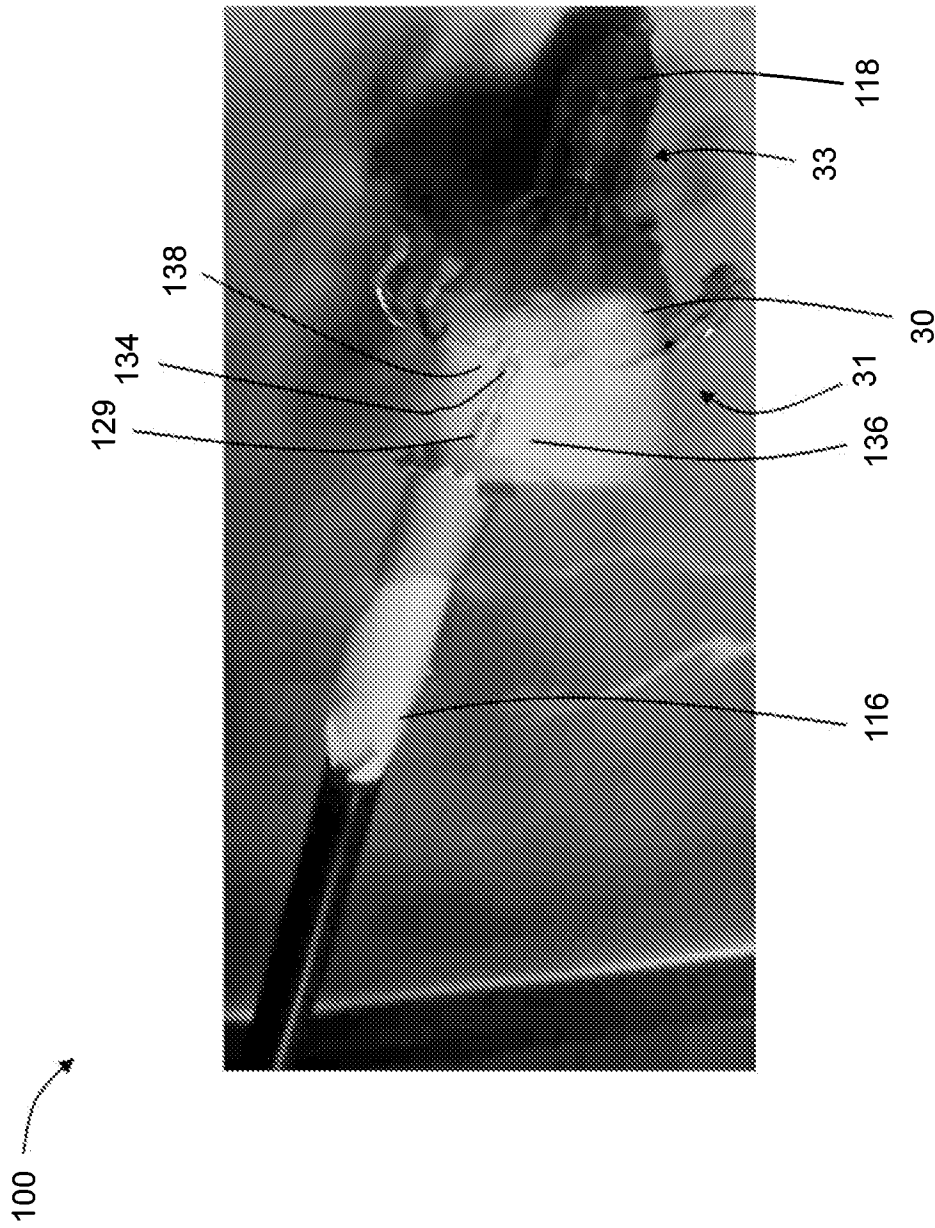

FIG. 18A

22/46

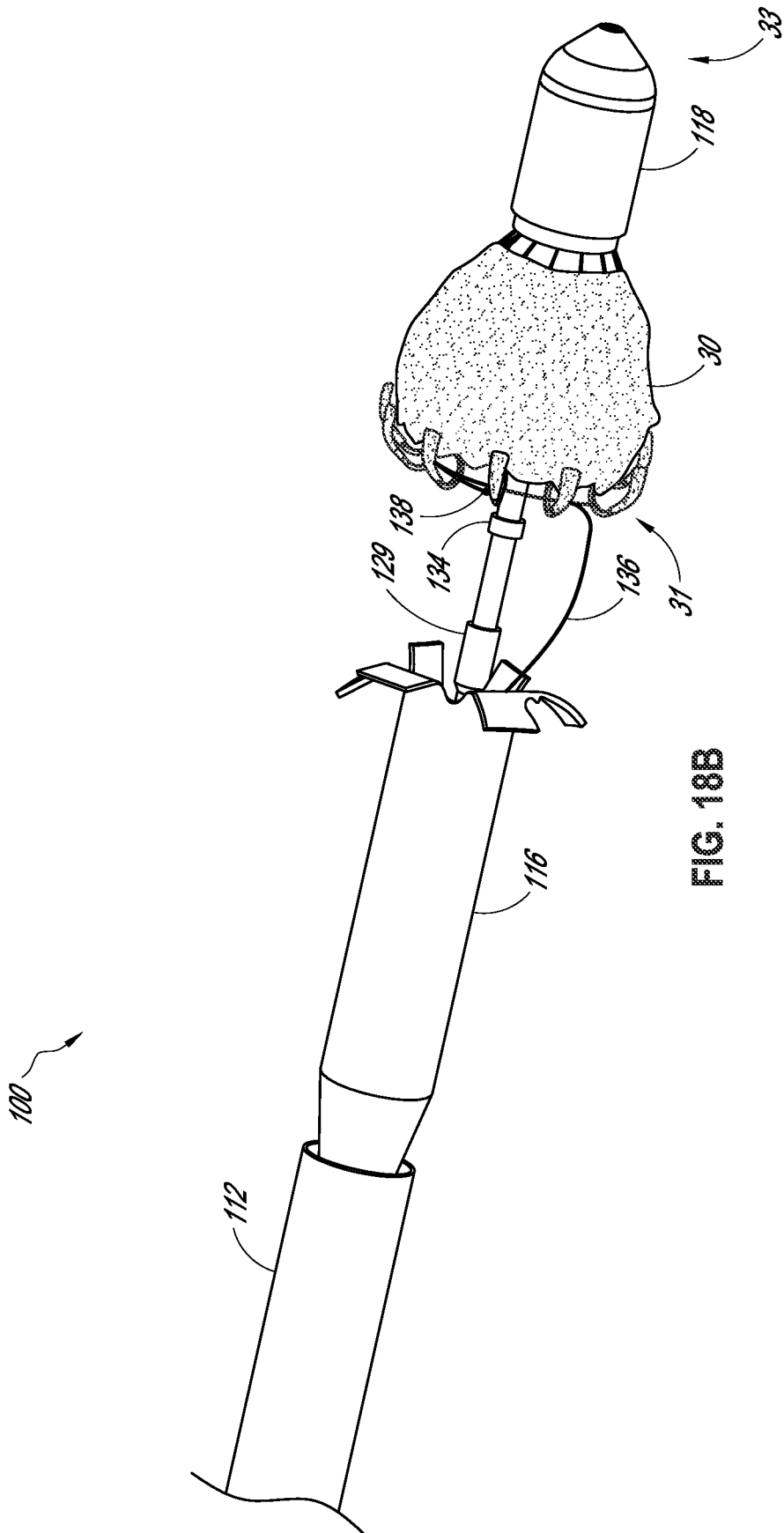

FIG. 18B

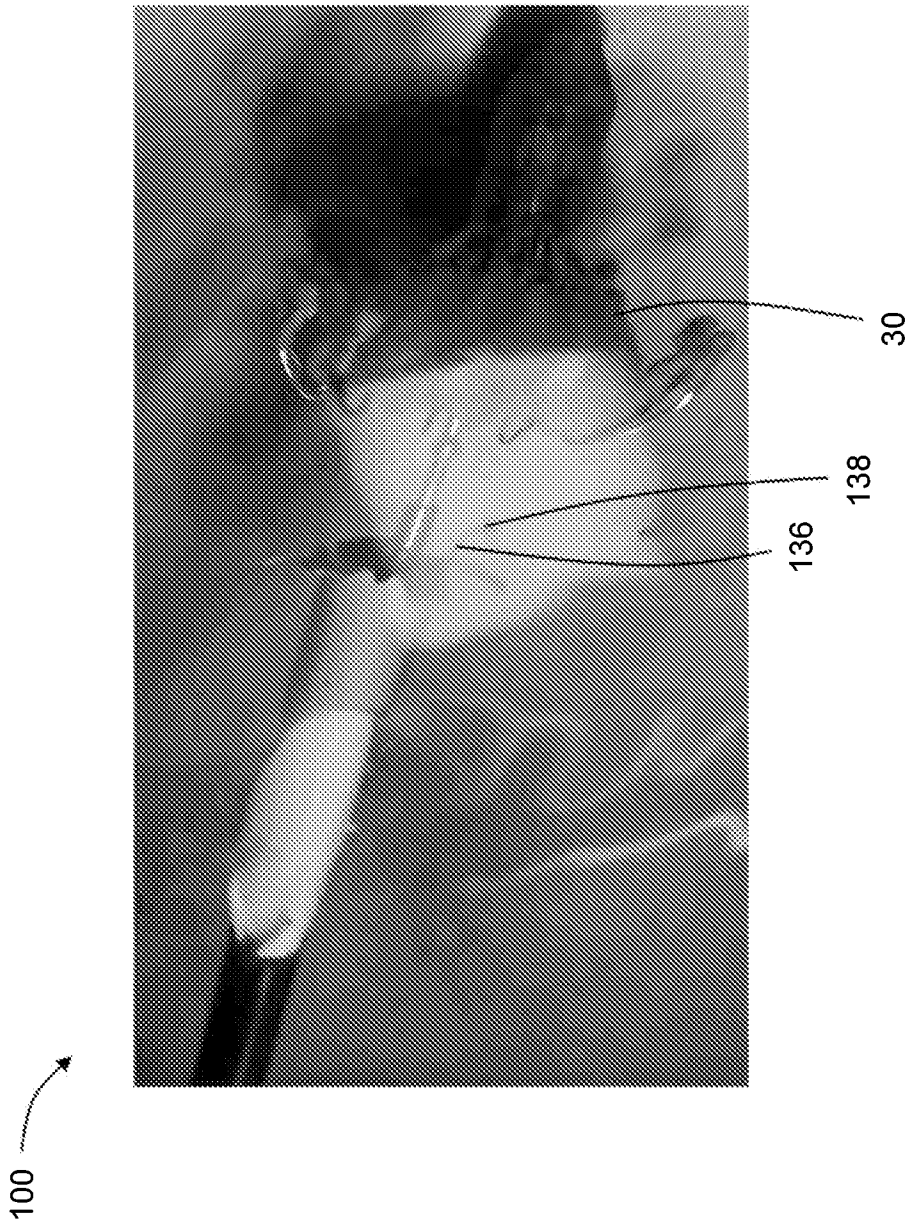

FIG. 19A

24/46

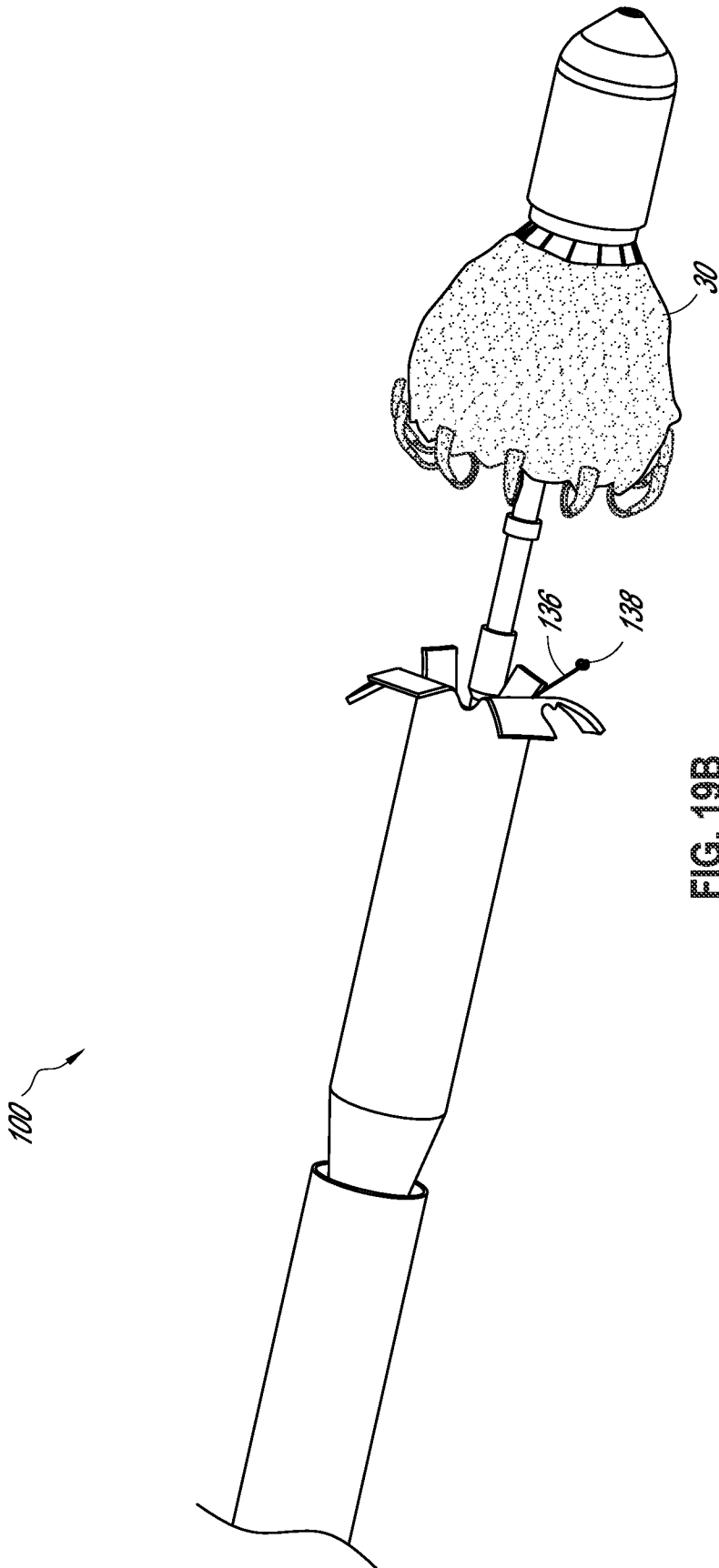

FIG. 19B

100 →

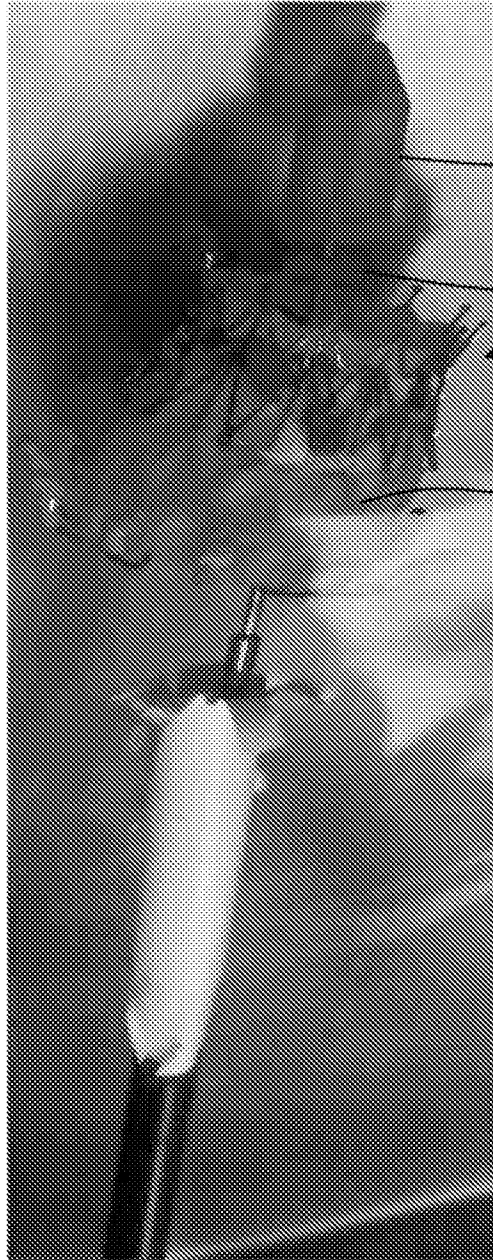

FIG. 20A

26/46

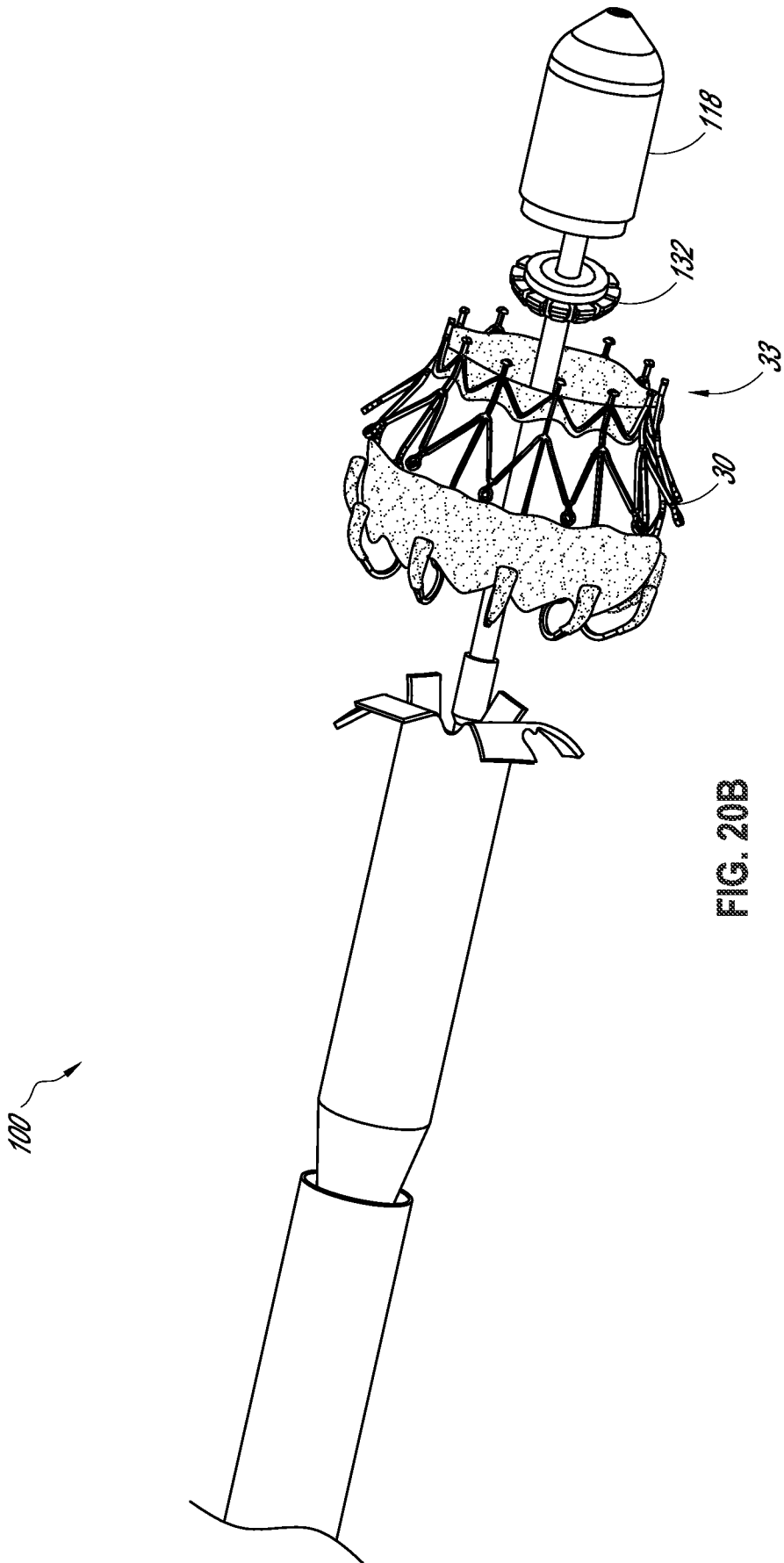

FIG. 20B

27/46

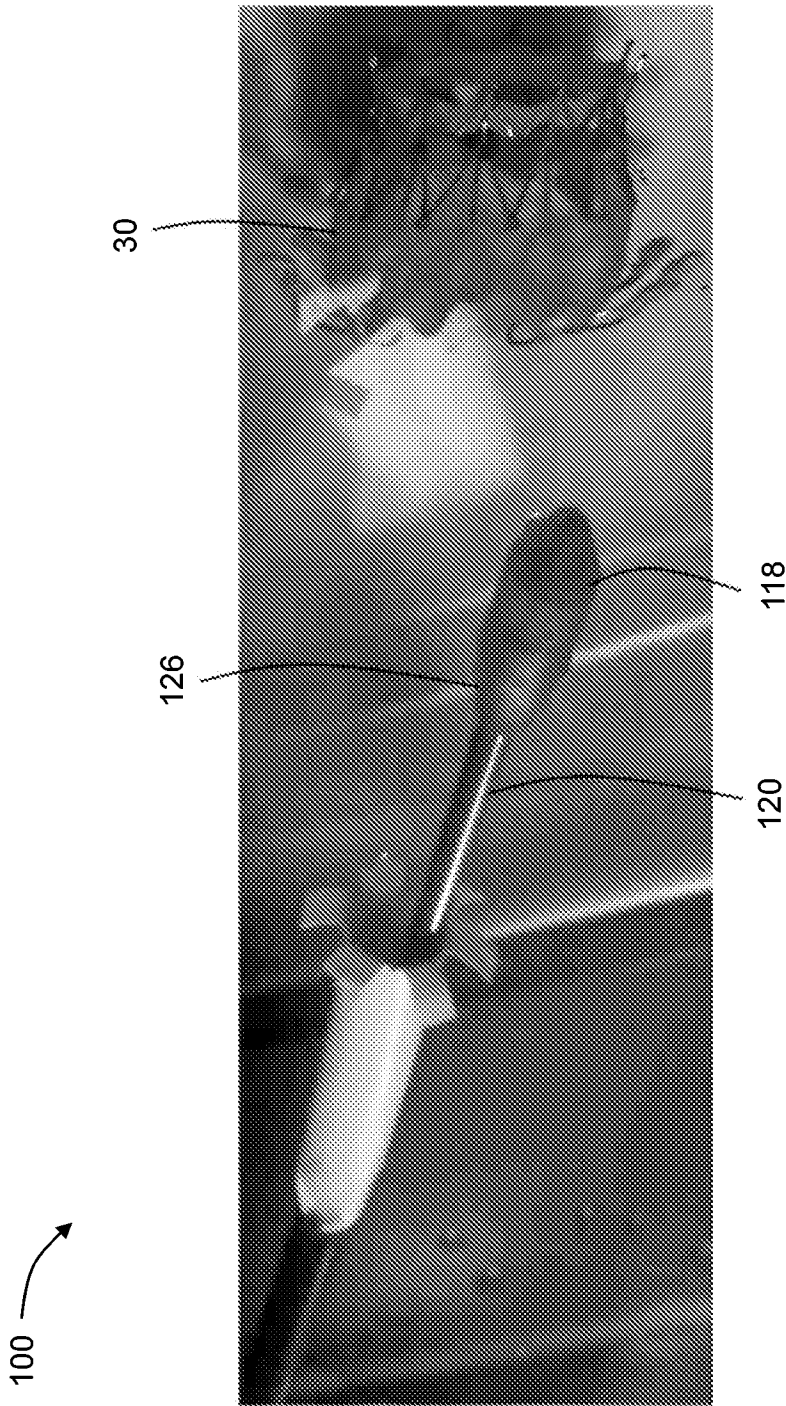

FIG. 21A

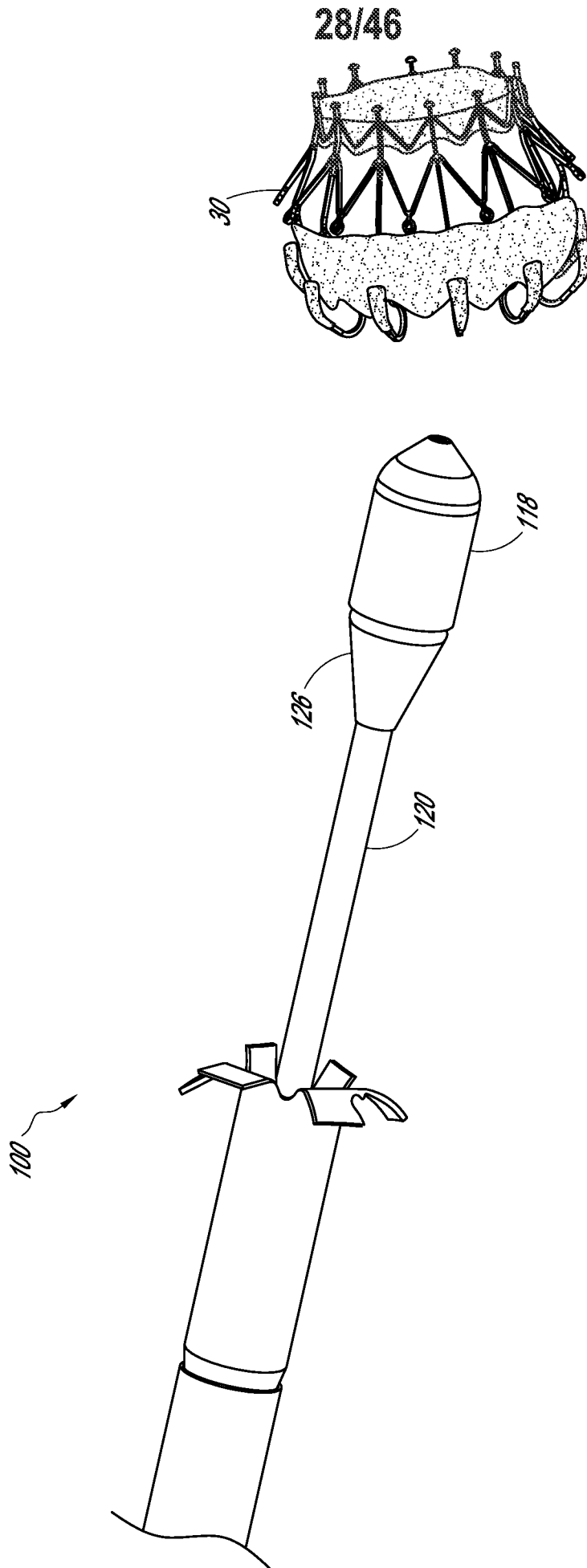

FIG. 21B

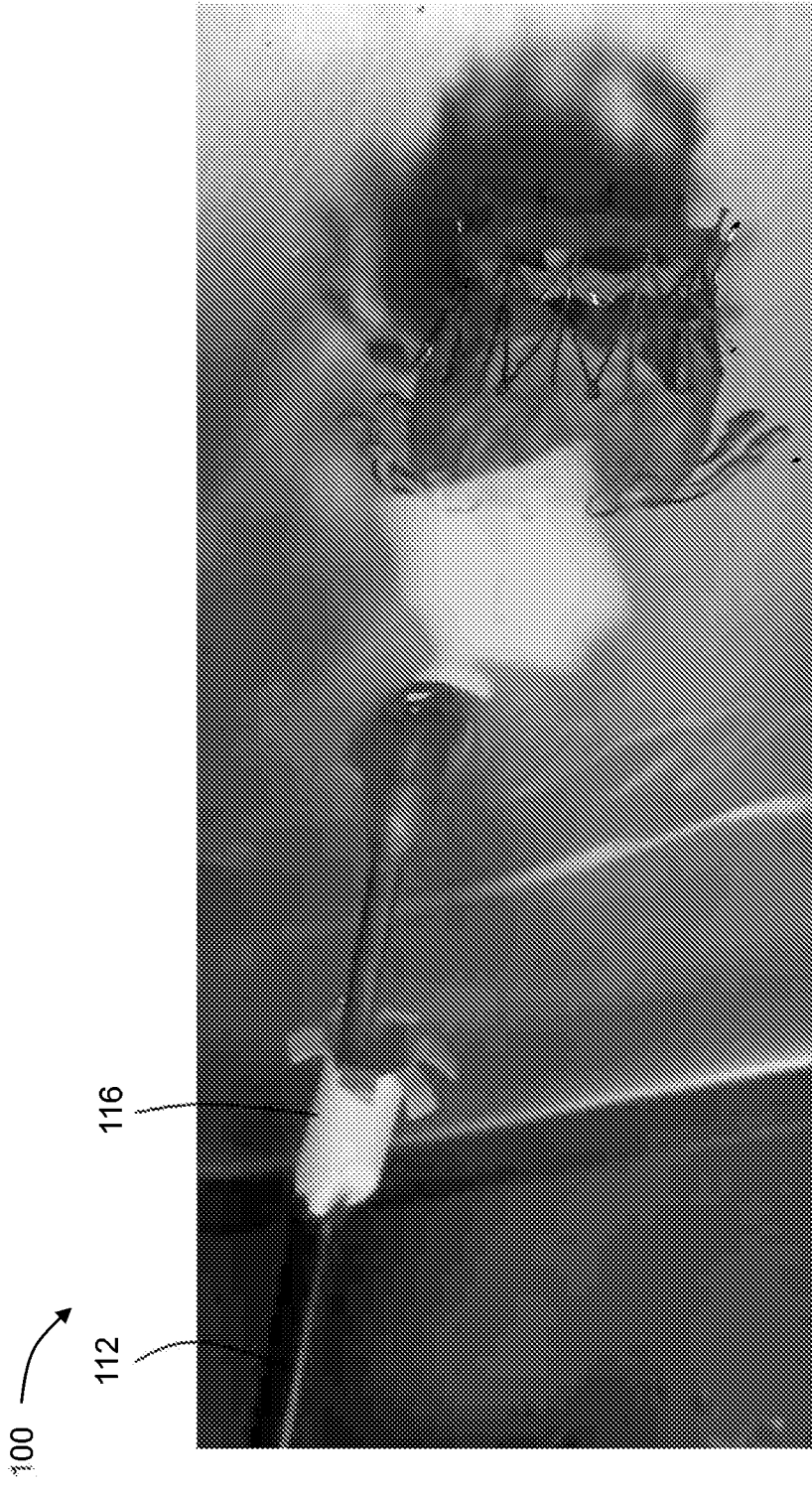

FIG. 22A

30/46

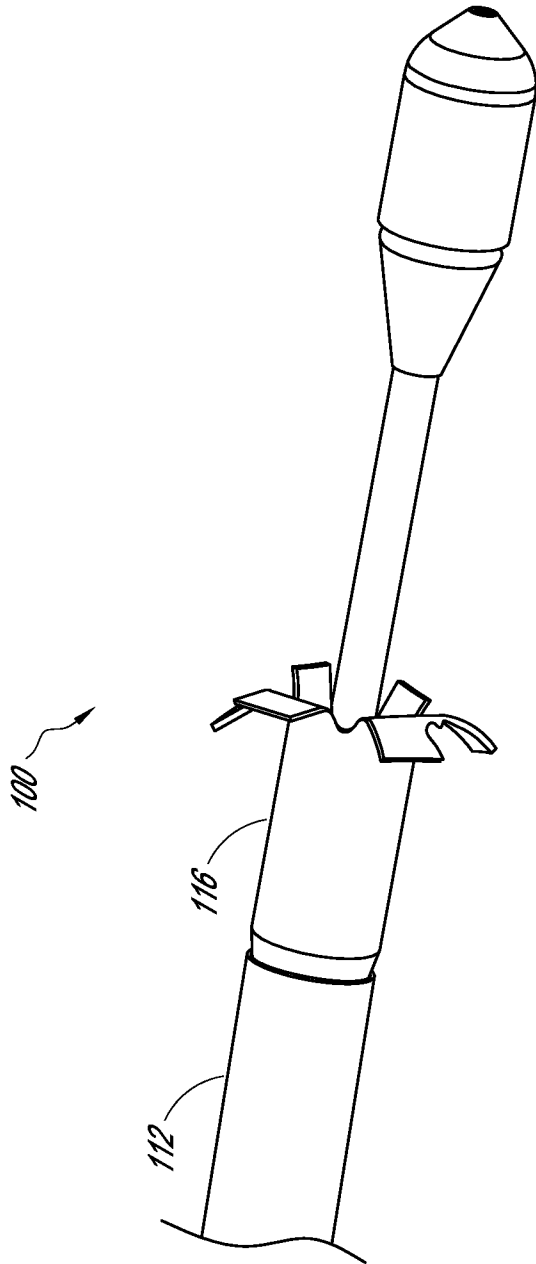
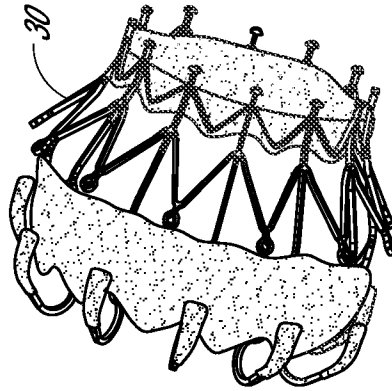
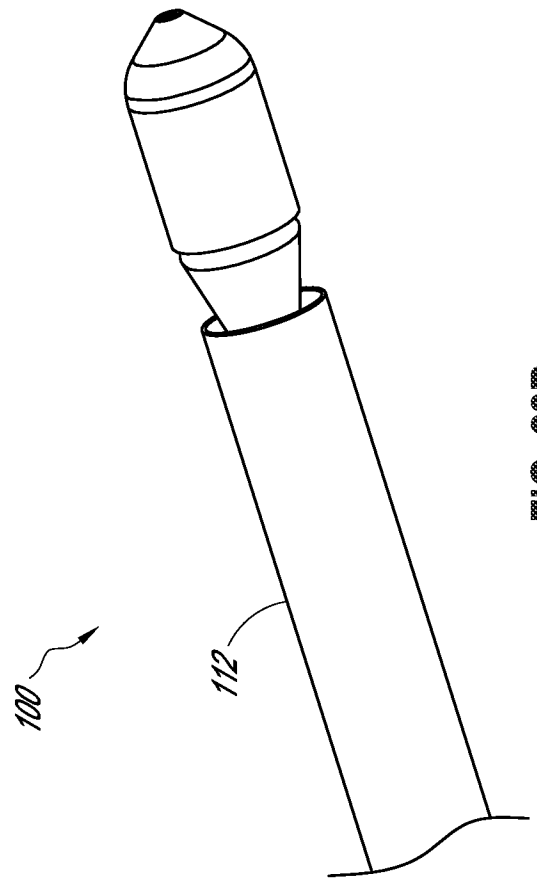
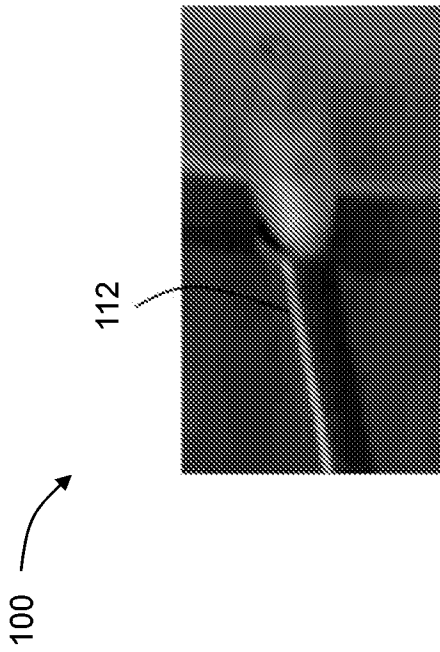

FIG. 22B



32/46

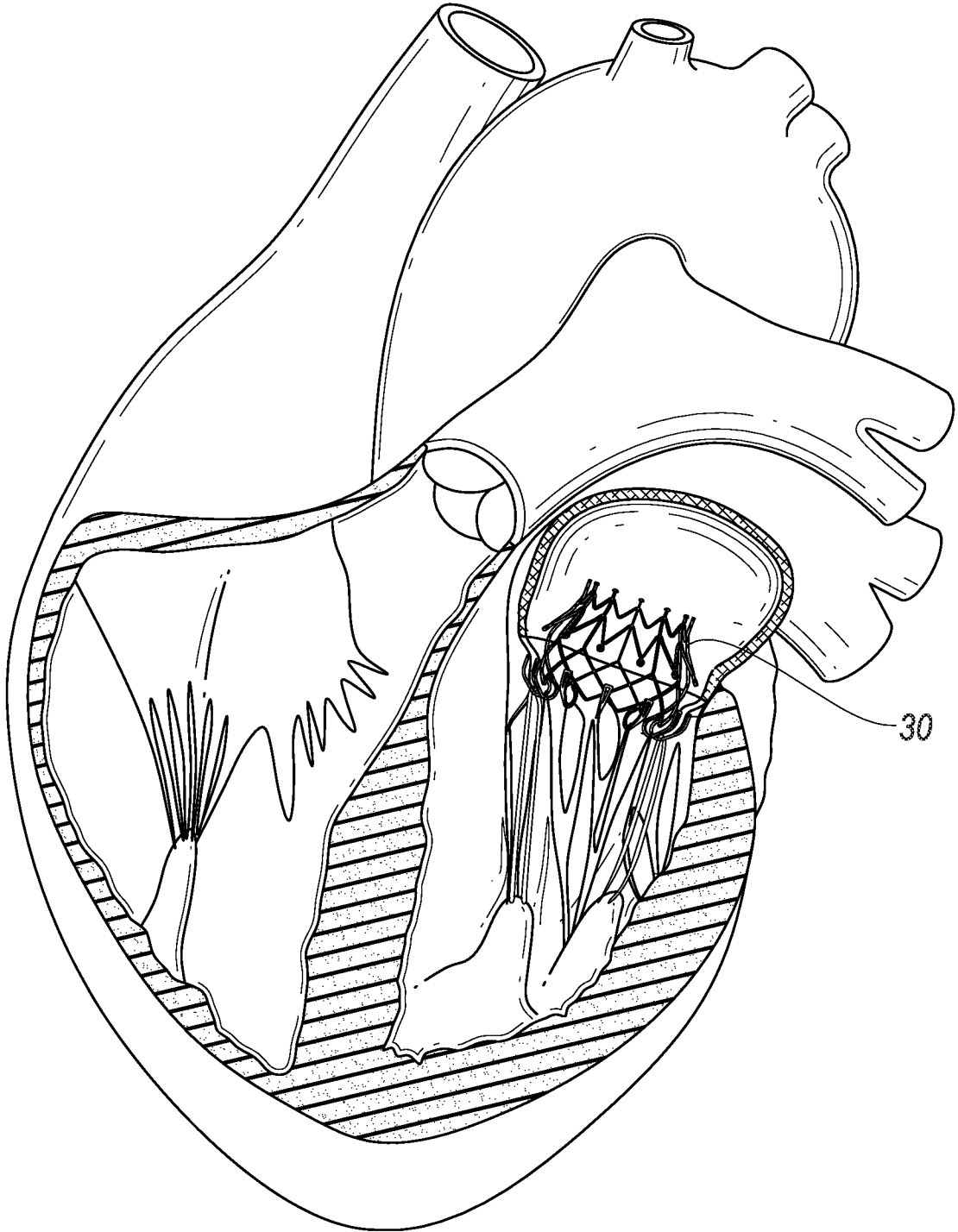

FIG. 24

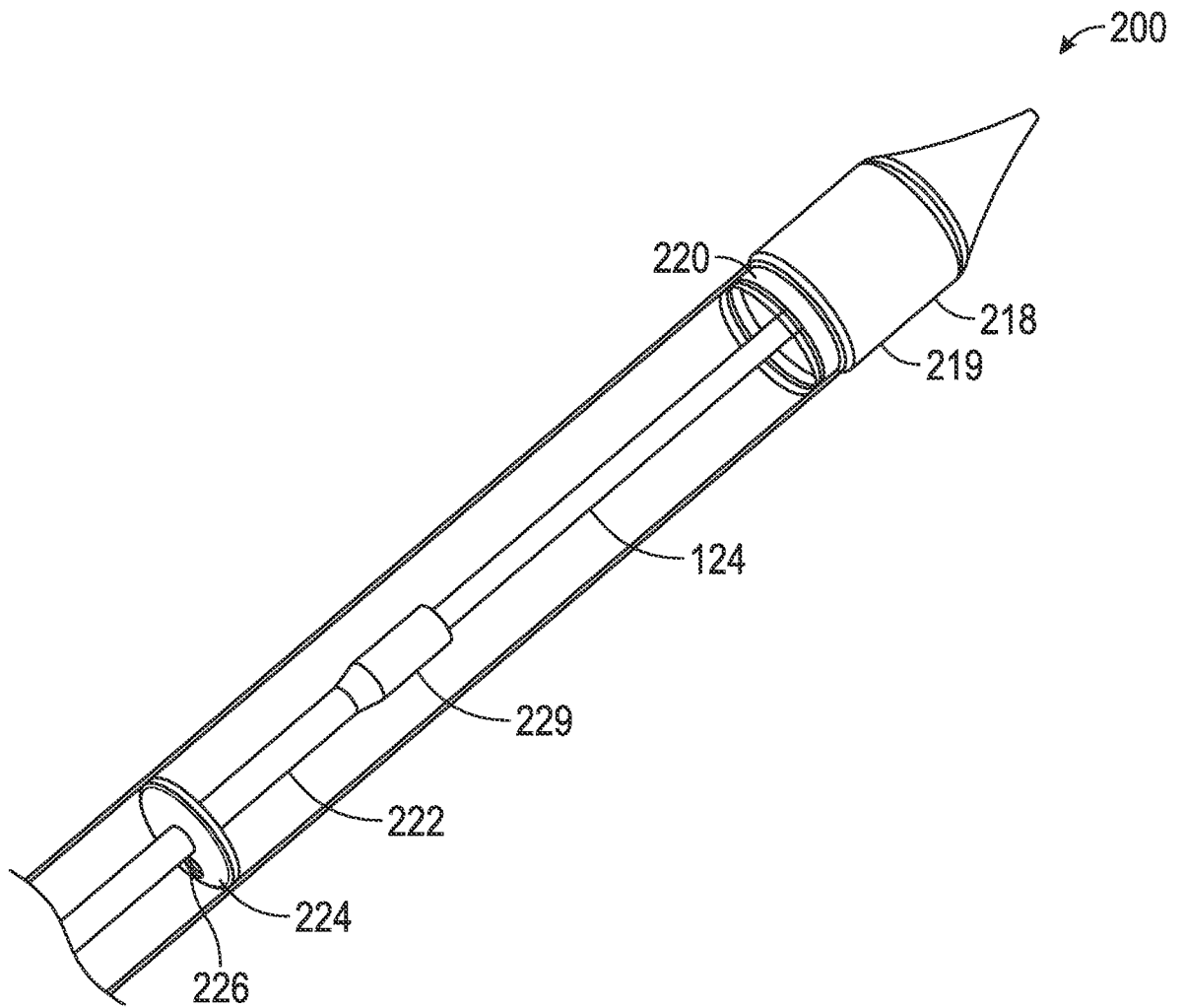

FIG. 25

34/46

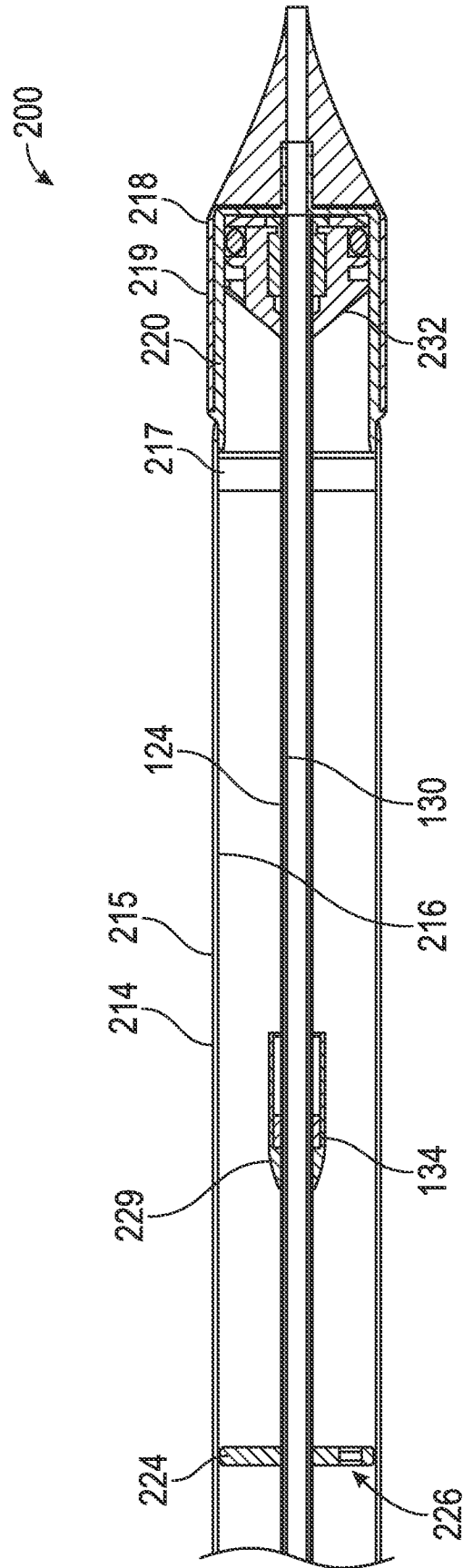

FIG. 26

35/46

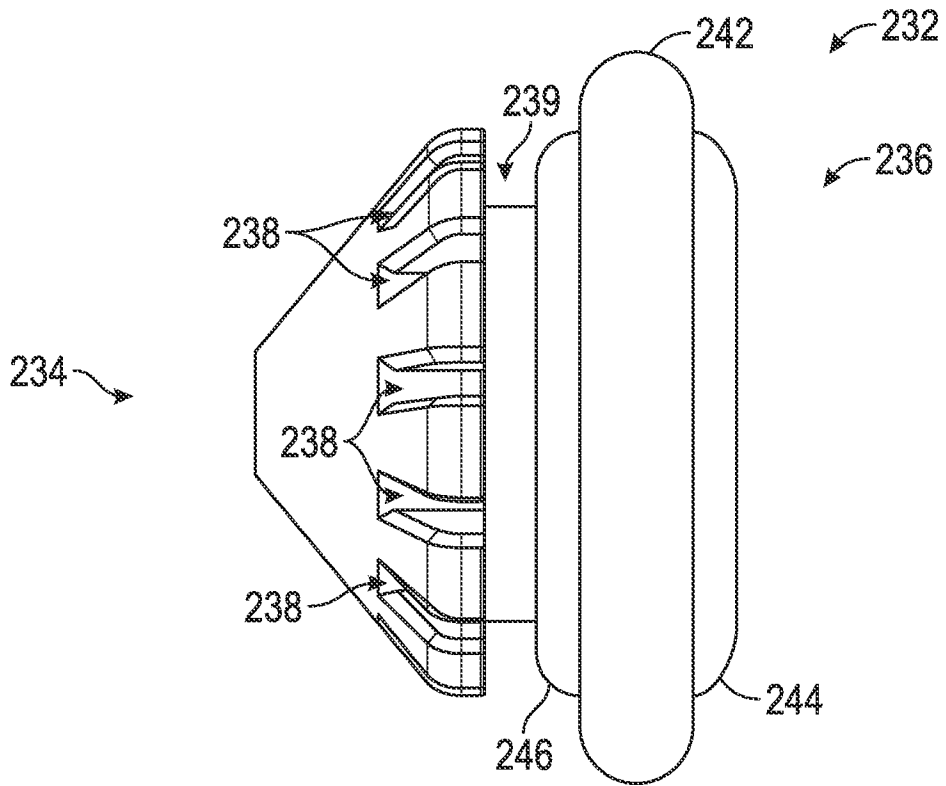

FIG. 27

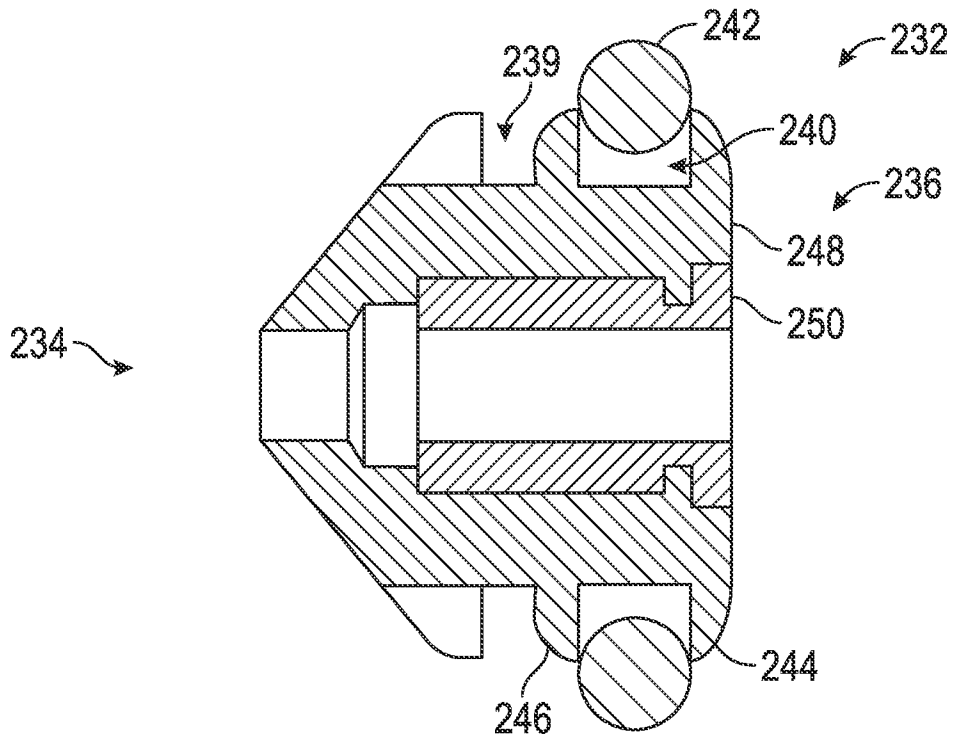

FIG. 28

36/46

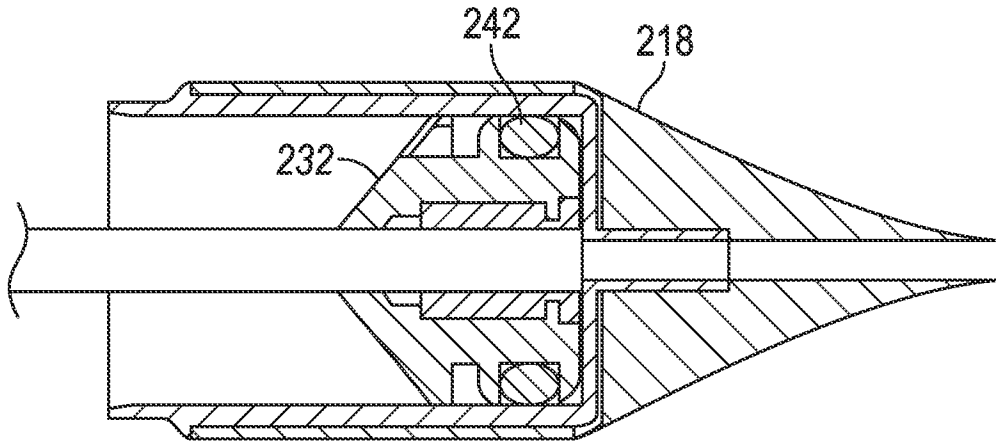

FIG. 29

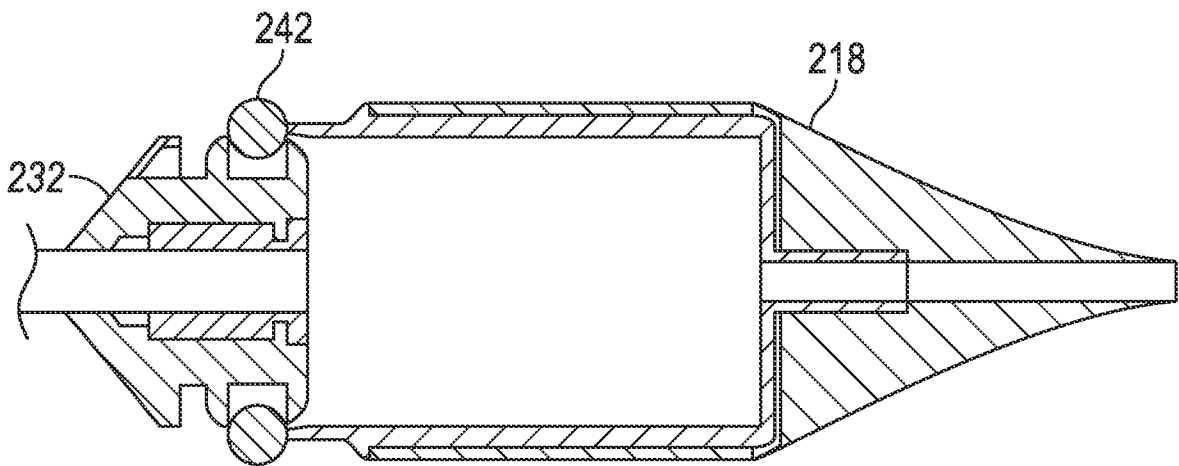

FIG. 30

37/46

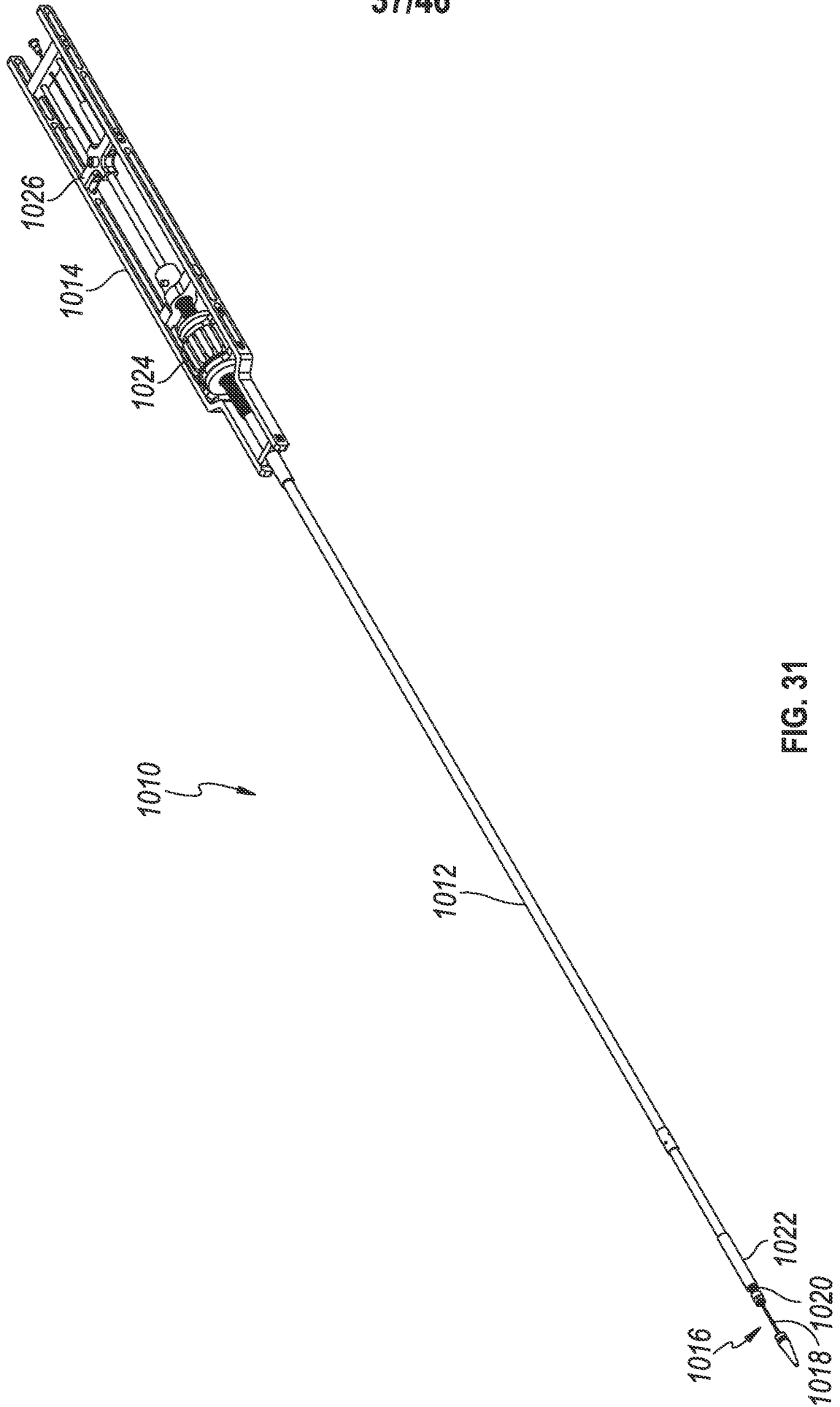

FIG. 31

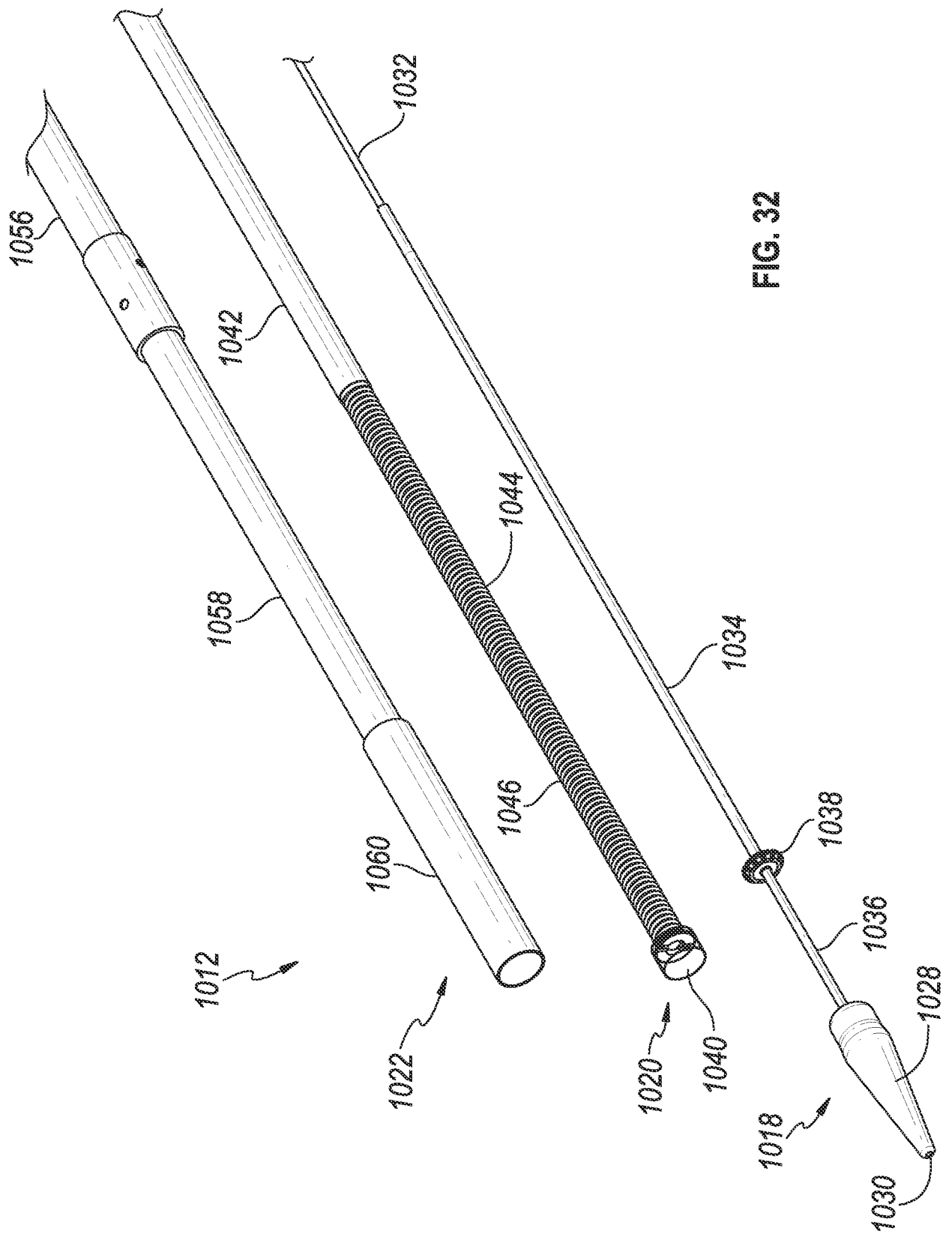

FIG. 32

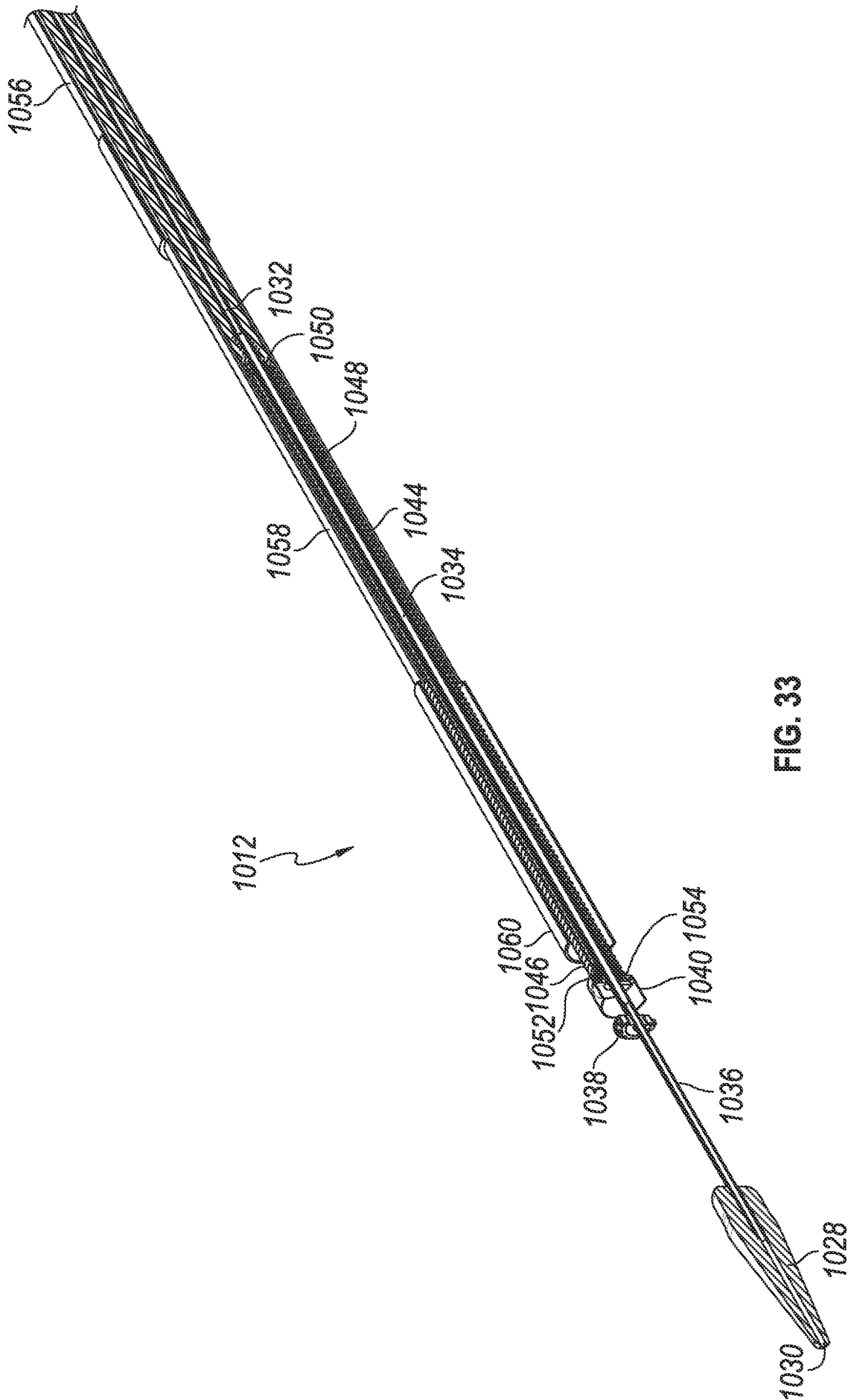

FIG. 33

40/46

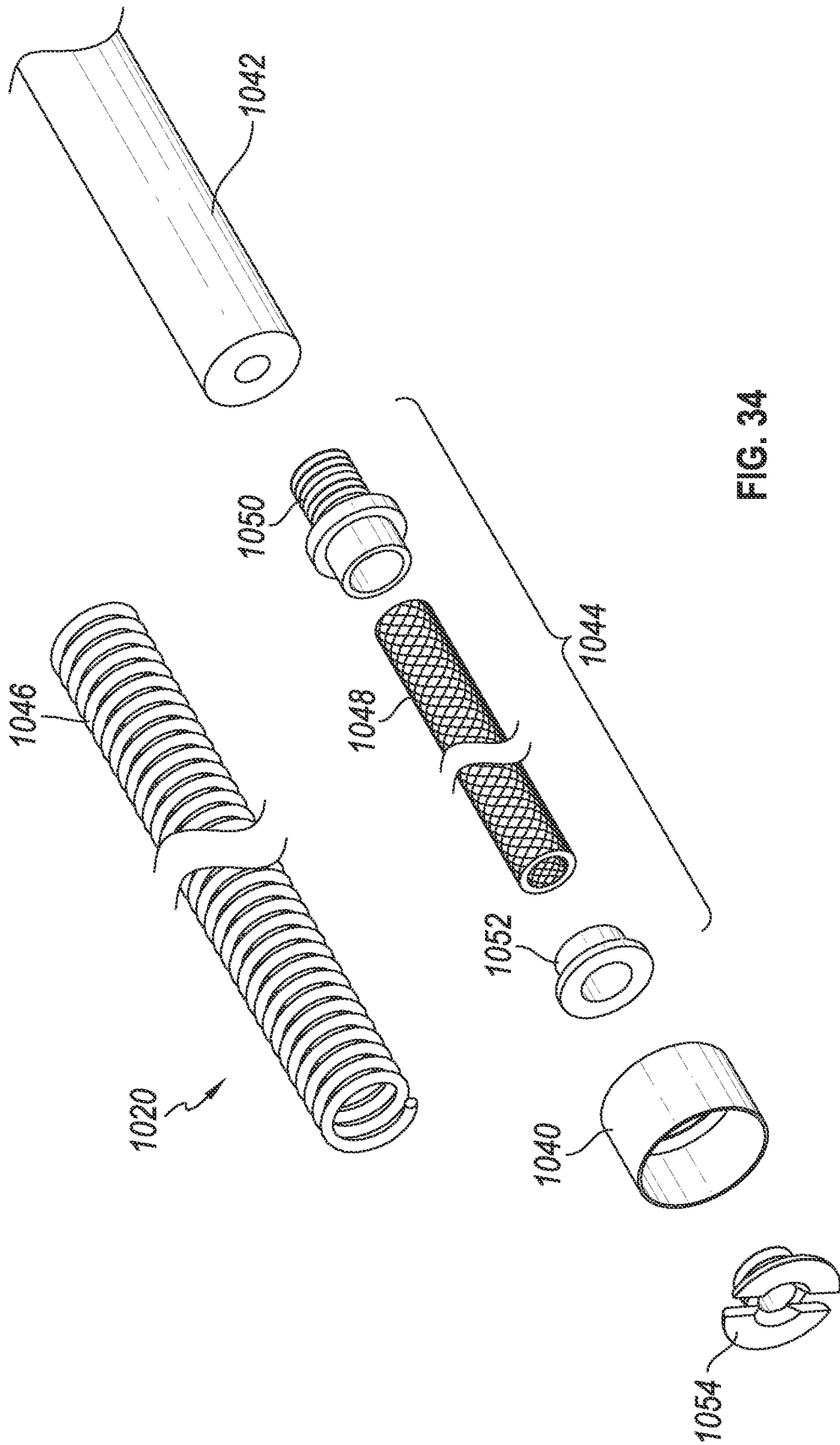
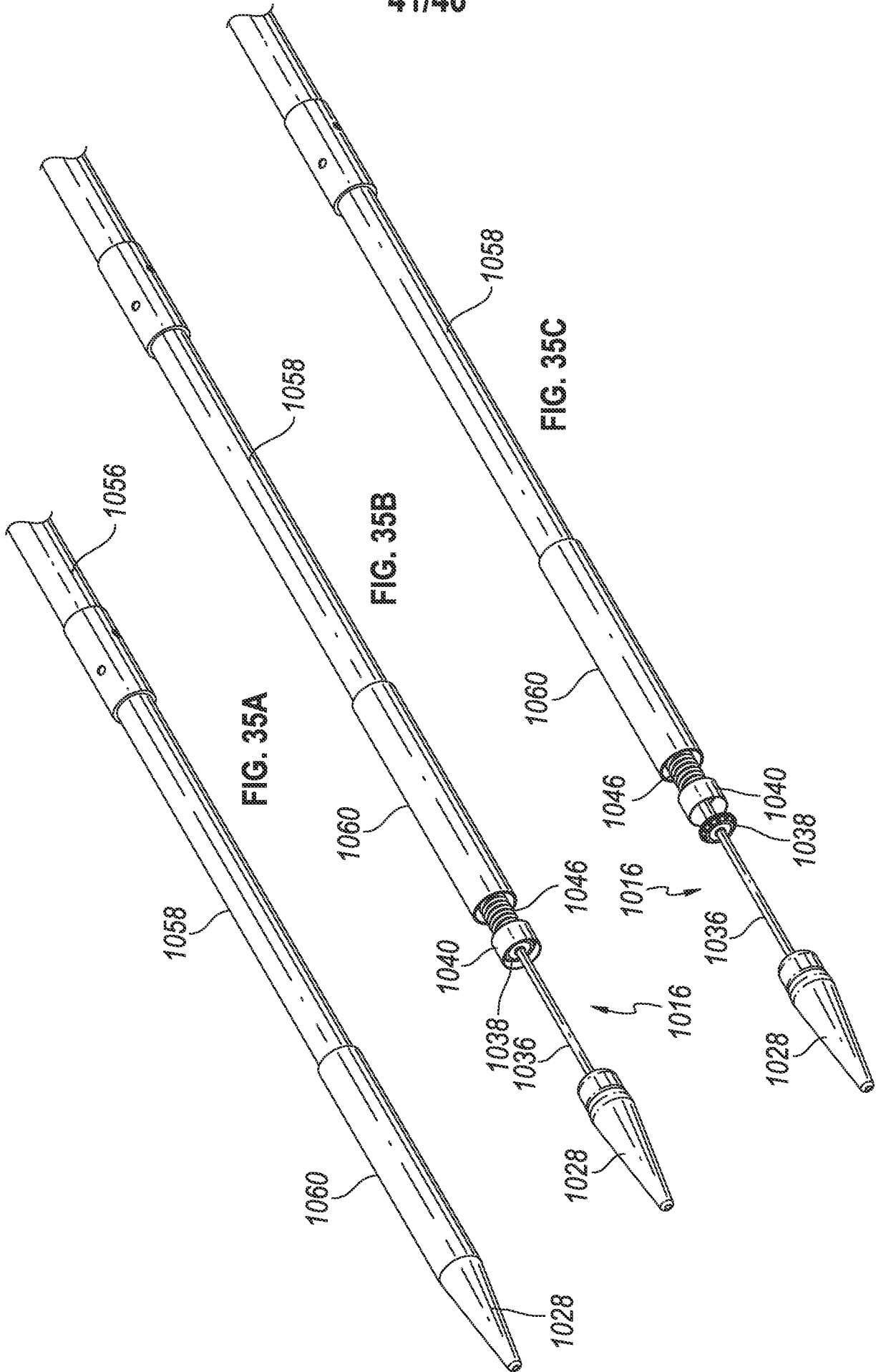
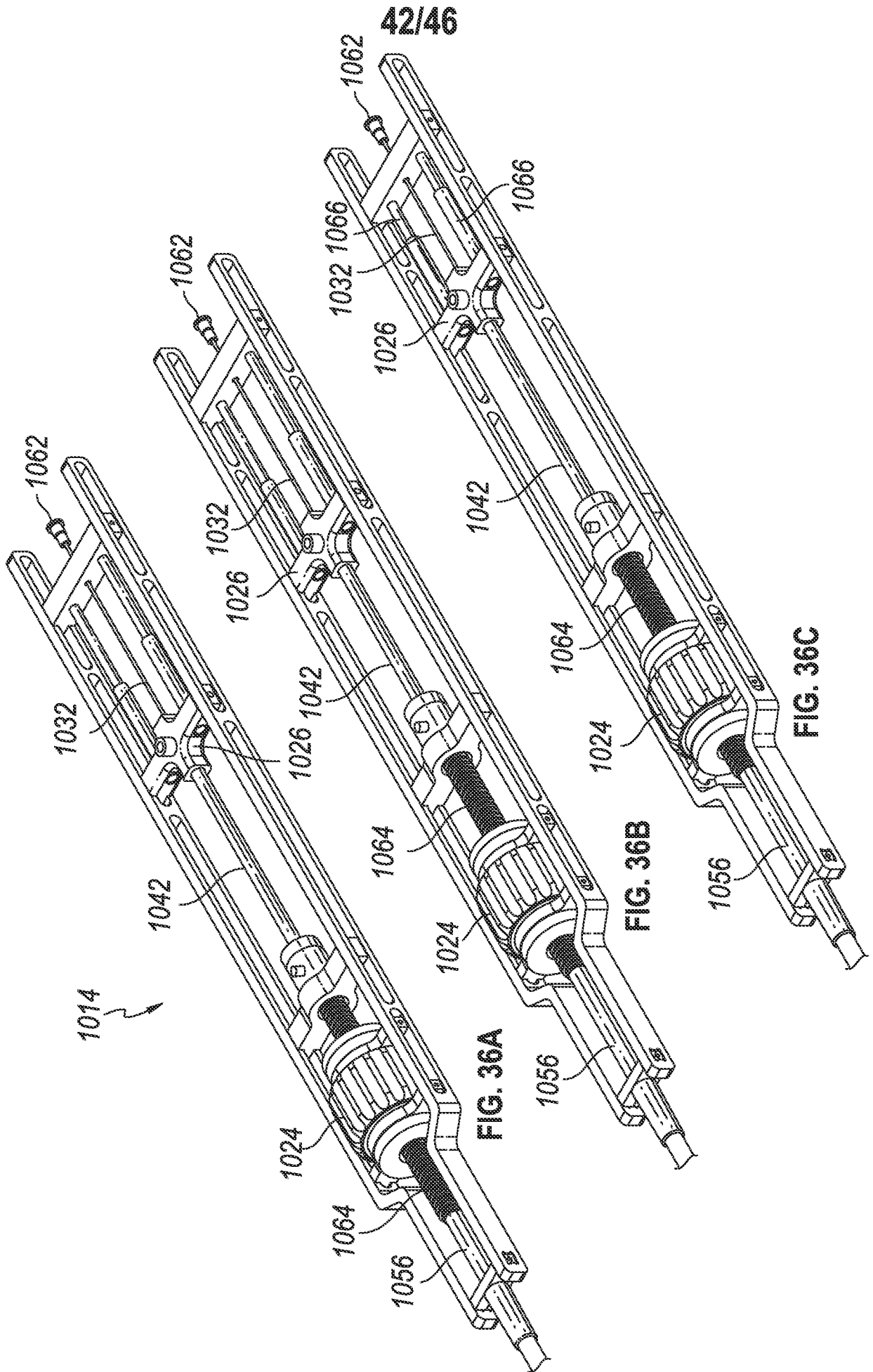

FIG. 34





43/46

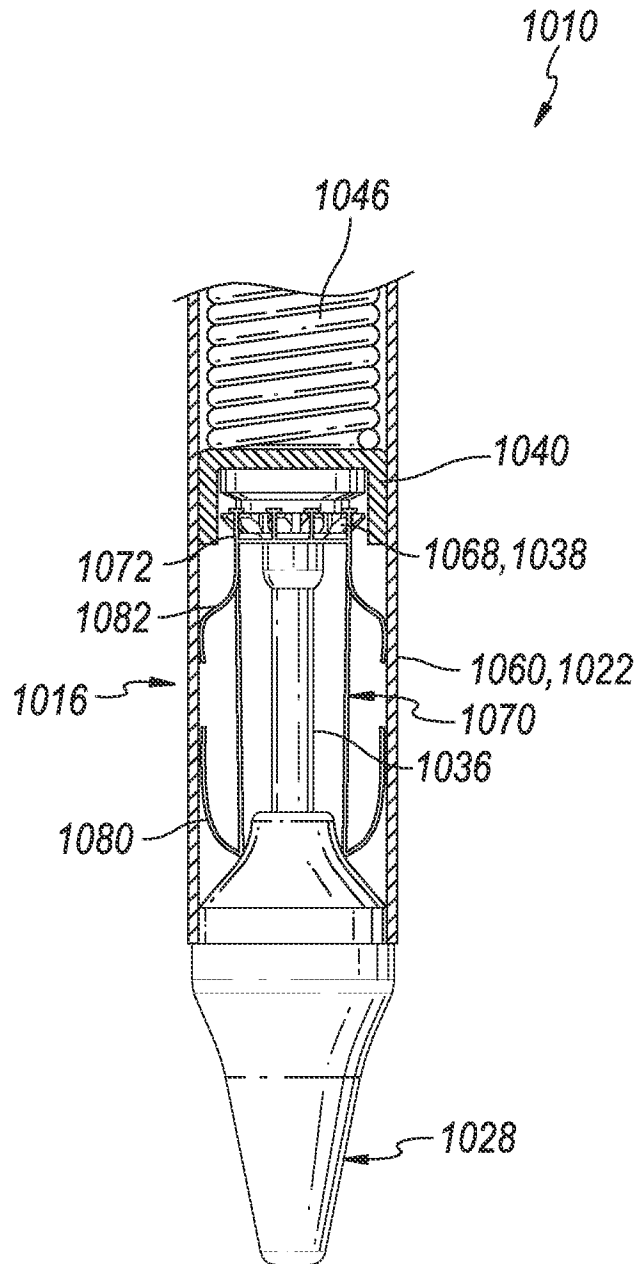

FIG. 37

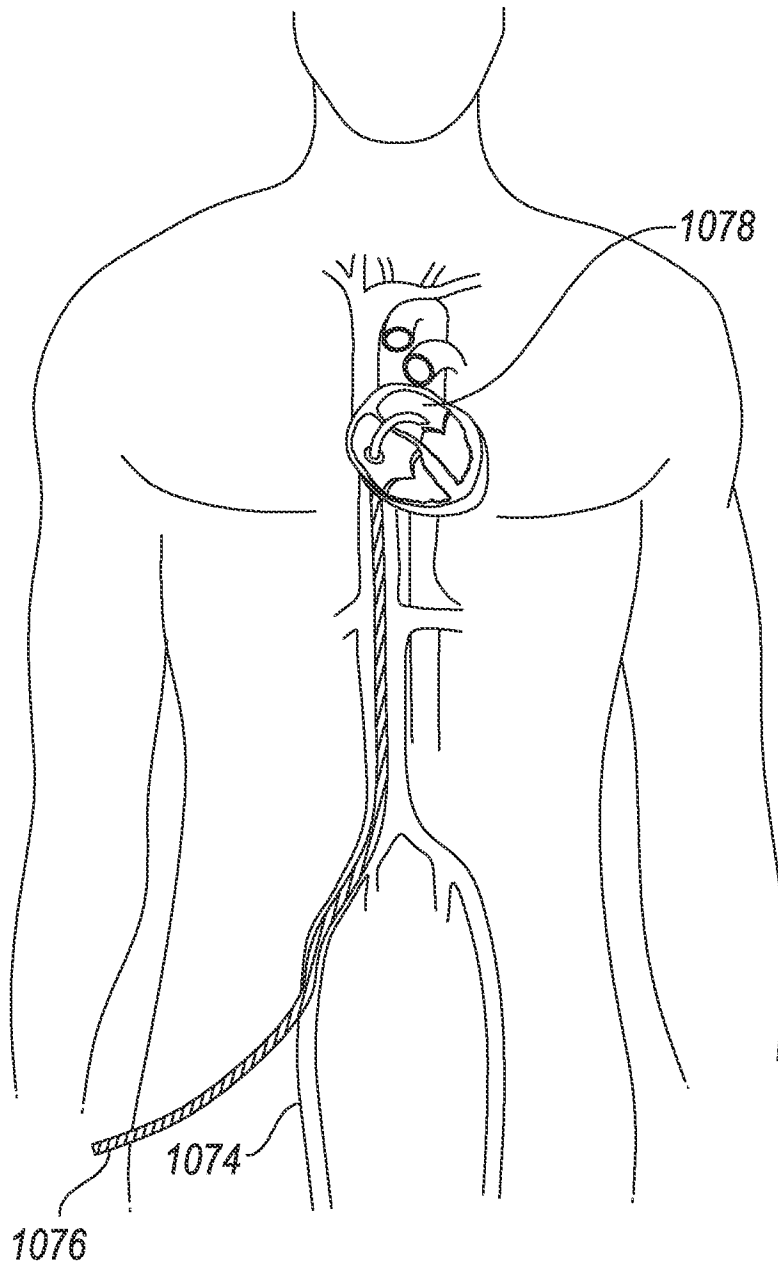

FIG. 38

45/46

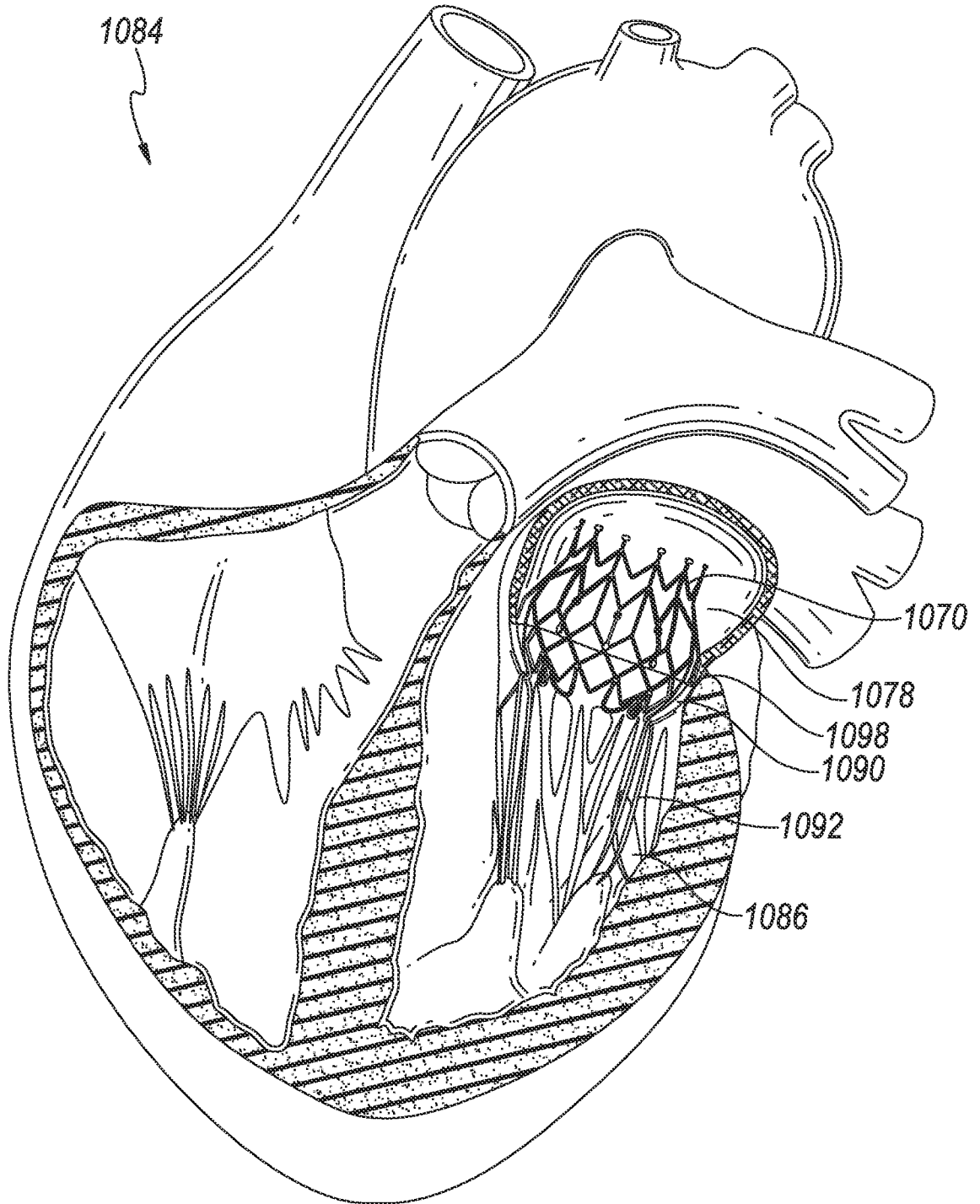

FIG. 39

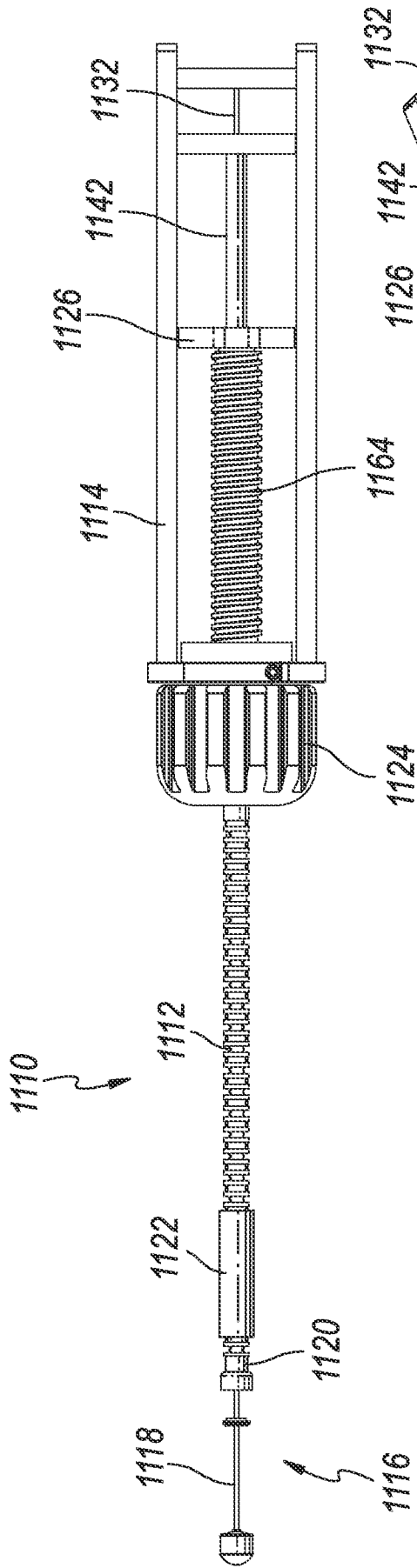

FIG. 40A

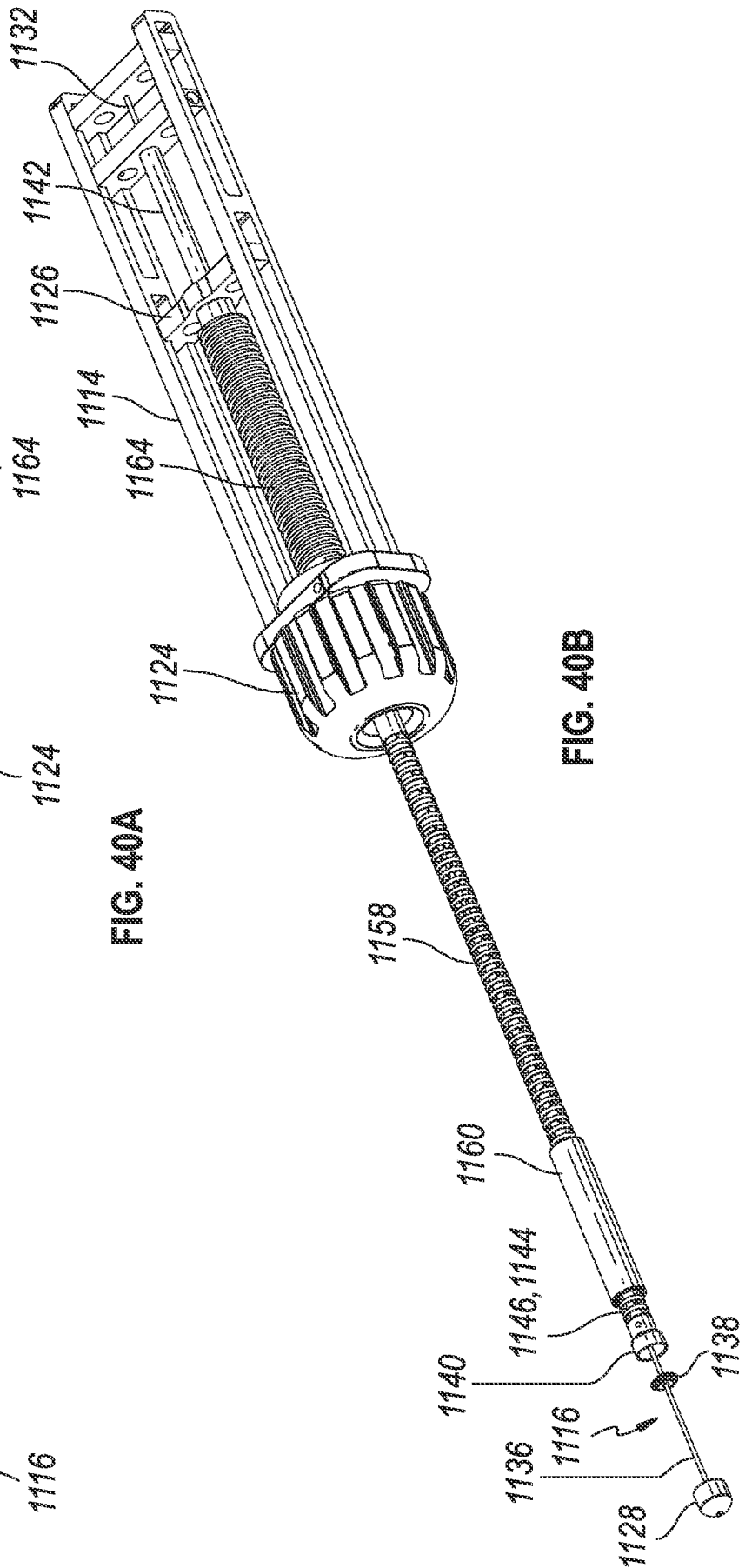

FIG. 40B

INTERNATIONAL SEARCH REPORT

International application No
PCT/US2015/016927

A. CLASSIFICATION OF SUBJECT MATTER
INV. A61F2/24
ADD.

According to International Patent Classification (IPC) or to both national classification and IPC

B. FIELDS SEARCHED
Minimum documentation searched (classification system followed by classification symbols)
A61F

Documentation searched other than minimum documentation to the extent that such documents are included in the fields searched

Electronic data base consulted during the international search (name of data base and, where practicable, search terms used)
EPO-Internal, WPI Data

C. DOCUMENTS CONSIDERED TO BE RELEVANT

Category*	Citation of document, with indication, where appropriate, of the relevant passages	Relevant to claim No.
X	US 2011/264198 A1 (MURRAY III ROBERT J [US] ET AL) 27 October 2011 (2011-10-27)	1,2,5-7, 11, 19-22, 26,27
Y	paragraph [0002]; figures 1A-3 paragraph [0019] - paragraph [0021] paragraph [0024] - paragraph [0026] -----	3,4
X	US 2010/049313 A1 (ALON DAVID [US] ET AL) 25 February 2010 (2010-02-25)	1-11, 19-22, 26,27
A	figures 9-54D paragraph [0140] paragraph [0142] paragraph [0151] - paragraph [0155] paragraph [0161] - paragraph [0162] ----- -/--	12-18

Further documents are listed in the continuation of Box C.

See patent family annex.

* Special categories of cited documents :

- "A" document defining the general state of the art which is not considered to be of particular relevance
- "E" earlier application or patent but published on or after the international filing date
- "L" document which may throw doubts on priority claim(s) or which is cited to establish the publication date of another citation or other special reason (as specified)
- "O" document referring to an oral disclosure, use, exhibition or other means
- "P" document published prior to the international filing date but later than the priority date claimed

- "T" later document published after the international filing date or priority date and not in conflict with the application but cited to understand the principle or theory underlying the invention
- "X" document of particular relevance; the claimed invention cannot be considered novel or cannot be considered to involve an inventive step when the document is taken alone
- "Y" document of particular relevance; the claimed invention cannot be considered to involve an inventive step when the document is combined with one or more other such documents, such combination being obvious to a person skilled in the art
- "&" document member of the same patent family

Date of the actual completion of the international search 30 April 2015	Date of mailing of the international search report 20/07/2015
--	--

Name and mailing address of the ISA/ European Patent Office, P.B. 5818 Patentlaan 2 NL - 2280 HV Rijswijk Tel. (+31-70) 340-2040, Fax: (+31-70) 340-3016	Authorized officer Portoni, Luisa
--	--

INTERNATIONAL SEARCH REPORT

International application No
PCT/US2015/016927

C(Continuation). DOCUMENTS CONSIDERED TO BE RELEVANT		
Category*	Citation of document, with indication, where appropriate, of the relevant passages	Relevant to claim No.
X	<p>WO 2009/091509 A1 (ST JUDE MEDICAL [US]; ALKHATIB YOUSEF F [US]) 23 July 2009 (2009-07-23)</p> <p>figures 1-30 paragraph [0075] - paragraph [0077] paragraph [0088] - paragraph [0097] paragraph [0125]</p> <p>-----</p>	<p>1-9,11, 12,14, 15, 19-23, 26,27</p>
Y	<p>WO 2010/121076 A2 (CARDIAQ VALVE TECHNOLOGIES INC [US]) 21 October 2010 (2010-10-21) paragraph [0086]; figures 14F, 14K, 14L paragraph [0095]</p> <p>-----</p>	<p>3,4</p>

INTERNATIONAL SEARCH REPORT

International application No.
PCT/US2015/016927

Box No. II Observations where certain claims were found unsearchable (Continuation of item 2 of first sheet)

This international search report has not been established in respect of certain claims under Article 17(2)(a) for the following reasons:

1. Claims Nos.: 45-53, 59-64, 84
because they relate to subject matter not required to be searched by this Authority, namely:
see FURTHER INFORMATION sheet PCT/ISA/210
2. Claims Nos.:
because they relate to parts of the international application that do not comply with the prescribed requirements to such an extent that no meaningful international search can be carried out, specifically:
3. Claims Nos.:
because they are dependent claims and are not drafted in accordance with the second and third sentences of Rule 6.4(a).

Box No. III Observations where unity of invention is lacking (Continuation of item 3 of first sheet)

This International Searching Authority found multiple inventions in this international application, as follows:

see additional sheet

1. As all required additional search fees were timely paid by the applicant, this international search report covers all searchable claims.
2. As all searchable claims could be searched without effort justifying an additional fees, this Authority did not invite payment of additional fees.
3. As only some of the required additional search fees were timely paid by the applicant, this international search report covers only those claims for which fees were paid, specifically claims Nos.:
4. No required additional search fees were timely paid by the applicant. Consequently, this international search report is restricted to the invention first mentioned in the claims; it is covered by claims Nos.:

1-27

Remark on Protest

- The additional search fees were accompanied by the applicant's protest and, where applicable, the payment of a protest fee.
- The additional search fees were accompanied by the applicant's protest but the applicable protest fee was not paid within the time limit specified in the invitation.
- No protest accompanied the payment of additional search fees.

FURTHER INFORMATION CONTINUED FROM PCT/ISA/ 210

This International Searching Authority found multiple (groups of) inventions in this international application, as follows:

1. claims: 1-27

A delivery system for controlled deployment of a replacement valve comprising a tether configured to at least partially encircle the replacement valve

2. claims: 28-44

A delivery system for controlled deployment of a replacement valve comprising a nose cone connected to the distal end of a nose cone shaft comprising a proximally facing opening to receive at least a first end of the replacement valve, a tether retention member on an inner retention shaft and a locking shaft configured to cooperate with the tether retention member to releasably engage a tether attached to the replacement valve.

3. claims: 54-58

A delivery system for controlled deployment of a replacement valve comprising a cover preventing or limiting contact between at least part of the expanding replacement valve and the surrounding tissue

4. claims: 65-78

A flexible delivery system for controlled deployment of a replacement mitral valve having an inner retention mechanism and an outer retention member configured to cover the proximal end of the compacted mitral valve.

5. claims: 79-83

A delivery system for an expandable prosthesis with an inner member and shaft assembly slidable over the inner member, the assembly comprising a compression member and a tension member concentrically arranged.

FURTHER INFORMATION CONTINUED FROM PCT/ISA/ 210

Continuation of Box II.1

Claims Nos.: 45-53, 59-64, 84

Methods of delivering an intraluminal frame assembly to intraluminal tissue at an in situ target location, and methods of delivery of a replacement valve or of an expandable prosthesis as defined in claims 45-53, 59-64 and 84 of the present international application are methods of treatment of the human or animal body by surgery. Indeed, the methods claimed in the cited claims 15-23 include surgical steps, as those necessary to deliver the prostheses to a target location in a patient's vessel or to a native valve. Thus, claims 45-53, 59-64 and 84 relate to subject-matter considered by this Authority to be covered by the provisions of Rule 39.1(iv) PCT, and no international search report will be established with respect to the subject-matter of these claims (Article 17(2)(a)(i) PCT).

INTERNATIONAL SEARCH REPORT

Information on patent family members

International application No PCT/US2015/016927

Patent document cited in search report	Publication date	Patent family member(s)	Publication date	
US 2011264198	A1	27-10-2011	CN 103491903 A	01-01-2014
			EP 2699201 A1	26-02-2014
			US 2011264198 A1	27-10-2011
			US 2014172075 A1	19-06-2014
			WO 2012145546 A1	26-10-2012

US 2010049313	A1	25-02-2010	AU 2009283878 A1	25-02-2010
			CA 2734190 A1	25-02-2010
			CN 102196784 A	21-09-2011
			EP 2331019 A2	15-06-2011
			JP 5677954 B2	25-02-2015
			JP 2012500665 A	12-01-2012
			US 2010049313 A1	25-02-2010
			US 2014163670 A1	12-06-2014
			WO 2010022138 A2	25-02-2010

WO 2009091509	A1	23-07-2009	AU 2009205739 A1	23-07-2009
			BR PI0906759 A2	07-07-2015
			CR 11464 A	20-08-2010
			EP 2240121 A1	20-10-2010
			JP 5591120 B2	17-09-2014
			JP 2011509742 A	31-03-2011
			US 2010286768 A1	11-11-2010
			WO 2009091509 A1	23-07-2009

WO 2010121076	A2	21-10-2010	AU 2010236288 A1	20-10-2011
			CA 2756049 A1	21-10-2010
			EP 2419050 A2	22-02-2012
			EP 2810620 A1	10-12-2014
			JP 2012523894 A	11-10-2012
			US 2010298931 A1	25-11-2010
			US 2013138207 A1	30-05-2013
			US 2013144380 A1	06-06-2013
			US 2014172085 A1	19-06-2014
			US 2014172086 A1	19-06-2014
			US 2014309731 A1	16-10-2014
			US 2015066140 A1	05-03-2015
			WO 2010121076 A2	21-10-2010
