

Aug. 4, 1959

T. M. McCARTY ET AL

2,897,709

ELECTRICAL PICKUP FOR STRINGED MUSICAL INSTRUMENTS

Filed Nov. 7, 1956

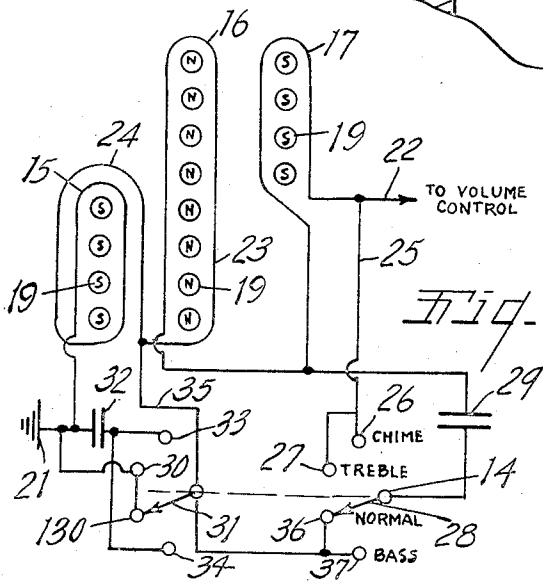
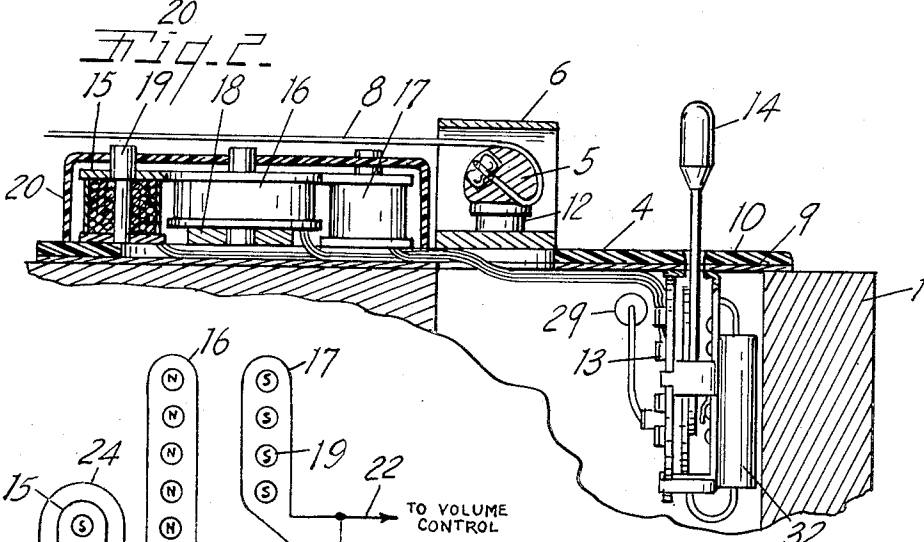
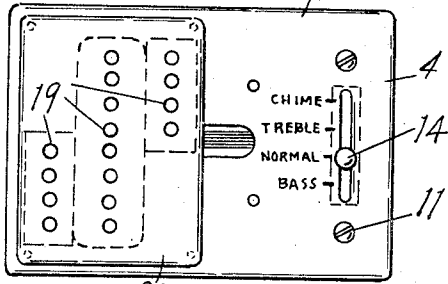
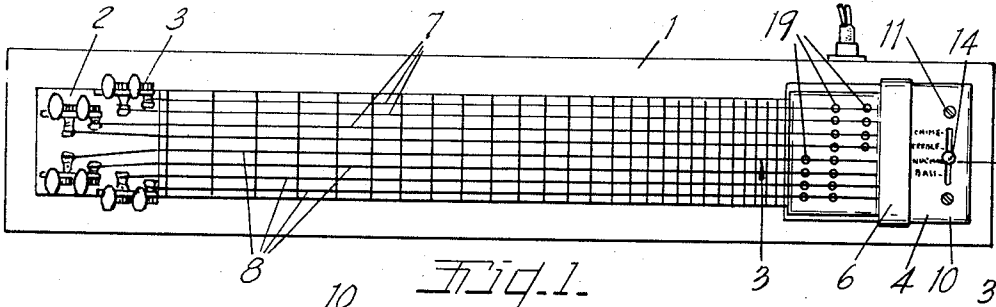

INVENTOR.  
Theodore M. McCarty  
Seth E. Lover  
BY *Orin C. Earle*  
Attorney.

1

2,897,709

## ELECTRICAL PICKUP FOR STRINGED MUSICAL INSTRUMENTS

Theodore M. McCarty and Seth E. Lover, Kalamazoo, Mich., assignors to Gibson, Inc., Kalamazoo, Mich.

Application November 7, 1956, Serial No. 620,882

20 Claims. (Cl. 84—1.15)

This invention relates to improvements in electrical pickup for stringed musical instruments.

The principal objects of this invention are:

First, to provide an electrical pickup for a multiple stringed metallic string instrument which can easily be adjusted for various tonal effects.

Second, to provide a pickup and circuit by means of which a single switch may be shifted between four positions to provide four different tonal effects.

Third, to provide an electrical pickup in which the impulses induced by the strings of the instrument are variously combined and modulated to effect various combinations of the tones induced by all of the strings together and the treble and bass strings separately.

Fourth, to provide a pickup having the foregoing advantages and characteristics which can be mounted closely adjacent to the bridge or anchor of the strings of the instrument.

Other objects and advantages of the invention will be apparent from a consideration of the following description and claims.

The drawings, of which there is one sheet illustrates a highly practical form of the pickup as applied to an eight stringed steel guitar instrument.

Fig. 1 is a plan view of the instrument.

Fig. 2 is an enlarged plan view of the electrical pickup with the strings and bridge of the instrument removed.

Fig. 3 is an enlarged fragmentary cross sectional view taken along the plane of the line 3—3 in Fig. 1.

Fig. 4 is a schematic wiring diagram of the electrical circuits of the pickup.

The invention is disclosed as applied to a console type steel guitar but is equally applicable to string instruments adapted to be held by the performer. The instrument disclosed consists of a body 1 which forms the sound box of the instrument and supports a keyboard 2. The keyboard is provided with adjustable anchors 3 for the strings of the instrument and the electrical pickup indicated generally at 4 embodies a fixed anchor or bridge 5 for the other ends of the strings.

In the example illustrated the bridge 5 is covered by a guard 6 and the instrument is provided with eight strings of which the four finer strings 7 are designated as treble strings and the four heavier strings 8 are designated as bass strings.

The body 1 is designed to be supported on legs not illustrated and the instrument is played by a performer seated in front of the instrument.

The pickup 4 more specifically consists of a mounting plate 9 having an insulating covering 10. The mounting plate is secured on the body in any suitable fashion as by screws 11. The bridge 5 consists of a rigid bar supported on pedestals 12 to support the strings 7 and 8 in spaced relationship above the keyboard 2.

Secured to the underside of the plate 9 and depending therefrom into the body of the instrument is a four position multiple contact switch 13 having an operating lever 14 projecting through the plate beyond the anchor 5 from

2

the strings. Positioned under the strings but closely adjacent to the bridge 5 are three coils which may be designated as the bass coil 15, common coil 16 and treble coil 17. The bass coil is wound or disposed in a plane parallel to the strings and lies under the bass strings only of the instrument. The common coil 16 underlies all of the strings while the treble coil 17 underlies only the treble strings of the instrument. All of the coils 15, 16 and 17 have approximately the same number of turns and it has been found that coils having ten thousand turns each are particularly suitable for the type of instrument illustrated.

With particular reference to Fig. 3 it will be noted that the bass and treble coils are vertically thicker than the common coil and this was done to make the treble coil as narrow as possible to permit moving all of the coils closer to the anchor or bridge 5. Due to the relatively thin character of the common coil 16 an insulating spacer block 18 is positioned under that coil to bring the tops of the coils to a common level. All of the coils are wound around a series of short permanent magnets or pole pieces 19 with each coil being provided with a pole piece associated with each string that cooperates with the coil. The pole pieces project upwardly to closely adjacent the underside of the strings and an insulating cover 20 is positioned over the coils with the pole pieces projecting therethrough. The function of the pole pieces or magnets 19 is to induce magnetism in the superimposed portions of the metallic strings so that vibration of the strings relative to the coils will induce voltages in the several coils that can be amplified and converted into sound by a loud speaker as is common in the art.

The electrical connections and relative polarities of the switch, coils and magnets is shown most clearly in the schematic circuit diagram in Fig. 4. It will be noted that the magnets associated with the common coil 16 all have their north poles at their upper ends while the magnets associated with the auxiliary bass and treble coils 15 and 17 have their south poles disposed upwardly. The circuit between the pickup and the amplifier is connected between a ground connection 21 and a conductor 22 which may be connected to a volume control element. A conductor 22 is connected to extend counterclockwise around the treble coil 17 and to connect to a conductor 23 that extends in a clockwise direction around the common coil 16 to a conductor 24. The conductor 24 is connected to extend in a counterclockwise direction around the bass coil 15, the end of which is connected to the ground 21.

Associated with the basic circuit of the several coils as described is a conductor 25 that extends from the lead wire 22 to a chime contact 26 and treble contact 27 associated with one movable contact 28 of the switch 13. The movable contact 28 is connected through a condenser 29 to the conductor 23 between the common and treble coils. The end of the bass coil 15 and the ground 21 are connected to a second treble contact 30 and a normal contact 130 associated with a second movable contact 31 of the switch. The ground is also connected through a second condenser 32 to a chime contact 33 and a bass contact 34 also associated with the movable contact 31. The movable contact 31 is connected through the conductor 35 to the conductor 24 between the common and bass coils and is also connected to a normal tone contact 36 and a bass tone contact 37 associated with the movable contact 28.

The condenser 32 has a value of the order of .05 microfarad while the condenser 29 has a value of the order of .003 microfarad. The physical position of the condensers is relatively unimportant and they are conventionally mounted directly on the switch structure 13 as illustrated in Fig. 4. It will be understood that the movable contacts 31 and 28 of the switch are ganged together

to move simultaneously between the two sets of chime, treble, normal and bass contacts.

The position and polarity of the several magnets is selected in order to obtain the maximum efficiency of the magnets. Thus considering the longitudinal section shown in Fig. 3 the north poles at the top of the magnets in the common coil joins in a magnetic flux circuit passing in a loop through the south poles at the top of the other magnets and down through the magnets in the bass and treble coils to return to the bottoms of the magnets in the common coil. The polarity of the magnets could be varied by changing the connections between the several coils. It will be noted that the direction of winding of the coils about the several magnets and the connections between the coils is such that the voltage induced in all of the coils by movement of a magnetized string thereover is additive between the conductor 22 to the volume control and the ground 21.

The common coil 16 is positioned so that the coil when bridged by the condenser 29 and in series with the treble coil 17 produces a total effect which is centered in the mid-frequency range between 200 and 2000 cycles. Thus with the switch contacts 28 and 31 adjusted to contact the terminals 36 and 130 there is created a series circuit through the treble coil 17 and common coil 16 to the conductor 35 and terminal 130 to ground. The bass coil is shunted out and is ineffective.

When the selector switch is adjusted to bass position the bass coil 15 is added in series with the other two coils and is bridged by the condenser 32. The condenser 29 remains bridged across the common coil. In this condition of the circuit the voltage induced in the bass coil is resonated by the condenser 32 and added to the voltage produced in the other coils to give a bass boost without effecting the voltage induced by the treble strings.

When the switch is moved to treble position a series circuit is maintained through the treble and common coils to the conductor 35 and treble contact 30 to ground and the condenser 29 is connected through the treble contact 27 and switch contact 28 across the treble coil 17 instead of the common coil 16. The high frequency shunting effect of the condenser 29 across the common coil is removed and the treble coil being of smaller size and inductance will be tuned to a high frequency. The condenser 29 also furnishes a path directly to the output for the high harmonics induced in the common coil. The voltage induced in the treble coil is slightly shifted in phase by the tuning effect of the condenser 29 but it also tends to add to the voltage induced in the common coil especially the high frequencies. All these effects tend to give a treble boost to the output of the instrument.

When the switch is adjusted to chime position all three coils are connected in series and the condenser 29 is bridged across the treble coil while the condenser 32 is bridged across the bass coil. In this condition of the circuit both the bass boost of the bass coil 15 and condenser 32 and the treble boost of the treble coil 17 and the condenser 29 are added to the output of the common coil to produce a chime effect.

Having thus described the invention, what is claimed as new and is desired to be secured by Letters Patent is:

1. An electrical pickup for a musical instrument having metallic bass and treble strings comprising a base having an anchor for said strings on its top and an electrical switch with two moving contacts on its bottom, a common control for moving each of said contacts between the contacts of two sets of four contacts and projecting above said base, a first coil positioned flatwise on said base under said bass strings and terminating short of said treble strings, a second coil positioned flatwise on said base under all said strings, a third coil positioned flatwise on said base under said treble strings and terminating short of said bass strings, all said coils having approximately the same number of turns and said first

and third coils being thicker and narrower than said second coil, said third coil being located closely adjacent said bridge and the other coils being positioned successively in edge to edge relation to said third coil, a first condenser of the order of .05 microfarad mounted on the frame of said switch, a second condenser relatively smaller than said first condenser and of the order of .003 microfarad mounted on the frame of said switch, electrical connections connecting said coils in series in counterclockwise direction around said third coil then clockwise around said second coil then counterclockwise about said first coil, said series connections forming an output circuit, a first group of magnets extending through said first coil and projecting upwardly under each of said bass strings, a second group of magnets extending through said second coil and projecting upwardly under each of said strings, a third group of magnets extending through said third coil and projecting upwardly under each of said treble strings, said first and third groups of magnets having their south pole upward and said second group of magnets having their north pole upward, electrical connections between said condensers and said switch and said series circuit for selectively connecting said larger condenser across said first coil with said smaller condenser across said second coil, or for connecting said smaller condenser across said second coil with said larger condenser and said first coil shunted from the circuit, or for connecting said smaller condenser across said third coil and shunting out said first coil with said larger condenser omitted from the circuit, or for connecting said larger condenser across said first coil with said smaller condenser connected across said third coil.

2. An electrical pickup for a musical instrument having metallic bass and treble strings comprising a base having an electrical switch with two moving contacts on its bottom, a common control for moving each of said contacts between the contacts of two sets of four contacts and projecting above said base, a first coil positioned flatwise on said base under said bass strings and terminating short of said treble strings, a second coil positioned flatwise on said base under all said strings, a third coil positioned flatwise on said base under said treble strings and terminating short of said bass strings, all said coils having approximately the same number of turns and being positioned successively in edge to edge relation, a first condenser mounted on the frame of said switch, a second condenser relatively smaller than said first condenser mounted on the frame of said switch, electrical connections connecting said coils in series whereby the voltages induced in each coil by a magnetized string vibrated over all coils are additive, said series connections forming an output circuit, a first group of magnets extending through said first coil and projecting upwardly under each of said bass strings, a second group of magnets extending through said second coil and projecting upwardly under each of said strings, a third group of magnets extending through said third coil and projecting upwardly under each of said treble strings, said first and third groups of magnets having the same pole upward and said second group of magnets having the opposite pole upward, electrical connections between said condensers and said switch and said series circuit for selectively connecting said larger condenser across said first coil with said smaller condenser across said second coil, or for connecting said smaller condenser across said second coil with said larger condenser and said first coil shunted from the circuit, or for connecting said smaller condenser across said third coil and shunting out said first coil with said larger condenser omitted from the circuit, or for connecting said larger condenser across said first coil with said smaller condenser connected across said third coil.

3. An electrical pickup for a musical instrument having metallic bass and treble strings comprising a base having an electrical switch on its bottom, a control for

5

said switch projecting above said base, a bass coil positioned flatwise on said base under said bass strings to the exclusion of others of said strings, a common coil positioned flatwise on said base under all said strings, a treble coil positioned flatwise on said base under said treble strings to the exclusion of others of said strings, all said coils having approximately the same number of turns and being positioned successively in edge to edge relation, a first condenser, a second condenser relatively smaller than said first condenser, electrical connections connecting said coils in series in one direction around said treble coil then in the opposite direction around said common coil then in the same direction about said bass coil as said treble coil, said series connections forming an output circuit, a first group of magnets extending through said bass coil and projecting upwardly under each of said bass strings, a second group of magnets extending through said common coil and projecting upwardly under each of said strings, a third group of magnets extending through said treble coil and projecting upwardly under each of said treble strings, said first and third groups of magnets having the same pole upward and said second group of magnets having the opposite pole upward, electrical connections between said condensers and said switch and said series circuit for selectively connecting said larger condenser across said bass coil with said smaller condenser across said common coil, or for connecting said smaller condenser across said common coil with said larger condenser and said bass coil shunted from the circuit, or for connecting said smaller condenser across said treble coil and shunting out said bass coil with said larger condenser omitted from the circuit, or for connecting said larger condenser across said bass coil with said smaller condenser connected across said treble coil.

4. An electrical pickup for a musical instrument having metallic bass and treble strings comprising a base having an electrical switch on its bottom, a control for said switch projecting above said base, a bass coil positioned flatwise on said base under said bass strings to the exclusion of others of said strings, a common coil positioned flatwise on said base under all said strings, a treble coil positioned flatwise on said base under said treble strings to the exclusion of others of said strings, all said coils having approximately the same number of turns and being positioned successively in edge to edge relation, a first condenser, a second condenser relatively smaller than said first condenser, electrical connections connecting said coils in series and in directions around said coils such that a magnetized string vibrated over all three coils will induce additive voltages in the coils, said series connections forming an output circuit, a first group of pole pieces extending through said bass coil and projecting upwardly under each of said bass strings, a group of magnets extending through said common coil and projecting upwardly under each of said strings, a second group of pole pieces extending through said treble coil and projecting upwardly under each of said treble strings, electrical connections between said condensers and said switch and said series circuit for selectively connecting said larger condenser across said bass coil with said smaller condenser across said common coil, or for connecting said smaller condenser across said common coil with said larger condenser and said bass coil shunted from the circuit, or for connecting said smaller condenser across said treble coil and shunting out said bass coil with said larger condenser omitted from the circuit, or for connecting said larger condenser across said bass coil with said smaller condenser connected across said treble coil.

5. An electrical pickup for a musical instrument having metallic bass and treble strings comprising a base having an electrical switch thereon, a control for said switch, a bass coil positioned flatwise on said base under said bass strings to the exclusion of others of said strings,

6

a common coil positioned flatwise on said base under all said strings, a treble coil positioned flatwise on said base under said treble strings to the exclusion of others of said strings, a first condenser, a second condenser relatively smaller than said first condenser, electrical connections connecting said coils in series in one direction around said common coil and in the opposite direction about the others of said coils, said series connections forming an output circuit, first magnetic means extending through said bass coil and projecting upwardly under each of said bass strings, second magnetic means extending through said common coil and projecting upwardly under each of said strings, third magnetic means extending through said treble coil and projecting upwardly under each of said treble strings, said first and third magnetic means having the same pole upward and said second magnetic means having the opposite pole upward, electrical connections between said condensers and said switch and said series circuit for selectively connecting said larger condenser across said bass coil with said smaller condenser across said common coil, or for connecting said smaller condenser across said common coil with said larger condenser and said bass coil shunted from the circuit, or for connecting said smaller condenser across said treble coil and shunting out said bass coil with said larger condenser omitted from the circuit, or for connecting said larger condenser across said bass coil with said smaller condenser connected across said treble coil.

6. An electrical pickup for a musical instrument having metallic bass and treble strings comprising a base of magnetically conductive material having an electrical switch thereon, a control for said switch, a bass coil positioned flatwise on said base under said bass strings to the exclusion of others of said strings, a common coil positioned flatwise on said base under all said strings, a treble coil positioned flatwise on said base under said treble strings to the exclusion of others of said strings, a first condenser, a second condenser, electrical connections connecting said coils in series and in directions around the coils whereby the voltages induced in the coils by a magnetized string vibrating thereover are additive, said series connections forming an output circuit, first magnetic means extending through said bass coil and projecting upwardly under each of said bass strings, second magnetic means extending through said common coil and projecting upwardly under each of said strings, third magnetic means extending through said treble coil and projecting upwardly under each of said treble strings, said second magnetic means being permanently magnetized, electrical connections between said condensers and said switch and said series circuit for selectively connecting said first condenser across said bass coil with said second condenser across said common coil, or for connecting said second condenser across said common coil with bass coil shunted out and said first condenser omitted from the circuit, or for connecting said second condenser across said treble coil and shunting out said bass coil with said first condenser omitted from the circuit, or for connecting said first condenser across said bass coil with said second condenser connected across said treble coil.

7. An electrical pickup for a musical instrument having magnetizable bass and treble strings comprising a base having an electrical switch thereon, a bass coil positioned flatwise on said base under said bass strings to the exclusion of others of said strings, a common coil positioned flatwise on said base under all said strings, a treble coil positioned flatwise on said base under said treble strings to the exclusion of others of said strings, all said coils having approximately the same number of turns, a first condenser, a second condenser relatively smaller than said first condenser, electrical connections connecting said coils in a series and in a direction around the coils whereby the voltages induced in the coils by

said strings vibrating thereover are additive, said series connections forming an output circuit, first magnetic means extending through said bass coil and projecting upwardly under each of said bass strings, second magnetic means extending through said common coil and projecting upwardly under each of said strings, third magnetic means extending through said treble coil and projecting upwardly under each of said treble strings, said first and third magnetic means having the same pole upward and said second magnetic means having the opposite pole upward, electrical connections between said condensers and said switch and said series circuit for selectively connecting said first condenser across said bass coil with said second condenser across said common coil, or for connecting said second condenser across said common coil with said bass coil shunted out and said first condenser omitted from the circuit, or for connecting said second condenser across said treble coil and shunting out said bass coil with said first condenser omitted from the circuit, or for connecting said first condenser across said bass coil with said second condenser connected across said treble coil.

8. An electrical pickup for a musical instrument having magnetizable bass and treble strings comprising a base having an electrical switch thereon, a bass coil positioned flatwise on said base under said bass strings to the exclusion of others of said strings, a common coil positioned flatwise on said base under all said strings, a treble coil positioned flatwise on said base under said treble strings to the exclusion of other of said strings, a first condenser, a second condenser, electrical connections connecting said coils in series in a direction around the coils whereby the voltages induced in the coils by a magnetized string vibrating thereover are additive, said series connections forming an output circuit, first magnetic means extending through said bass coil and projecting upwardly under each of said bass strings, second magnetic means extending through said common coil and projecting upwardly under each of said strings, third magnetic means extending through said treble coil and projecting upwardly under each of said treble strings, said first and third magnetic means having the same pole upward and said second magnetic means having the opposite pole upward, electrical connections between said condensers and said switch and said series circuit for selectively connecting said first condenser across said bass coil with said second condenser across said common coil, or for connecting said second condenser across said common coil with said bass coil shunted out and said first condenser omitted from the circuit, or for connecting said second condenser across said treble coil and shunting out said bass coil with said first condenser omitted from the circuit, or for connecting said first condenser across said bass coil with said condenser connected across said treble coil.

9. An electrical pickup for a musical instrument having magnetizable bass and treble strings comprising a base, an electrical switch, a bass coil positioned flatwise on said base under said bass strings to the exclusion of others of said strings, a common coil positioned flatwise on said base under all said strings, a treble coil positioned flatwise on said base under said treble strings to the exclusion of others of said strings, all said coils having approximately the same number of turns, a first condenser, a second condenser, electrical connections connecting said coils in series and in a direction around said coils whereby the voltages induced in the coils by a magnetized string vibrated thereover are additive, said series connections forming an output circuit, first magnet means extending above said bass coil and projecting upwardly under each of said bass strings, second magnet means extending above said common coil and projecting upwardly under each of said strings, third magnet means extending above said treble coil and projecting upwardly under each of said treble strings, said first and third

magnet means having the same pole upward and said second magnet means having the opposite pole upward, electrical connections between said condensers and said series circuit for selectively connecting said first condenser across said bass coil with said second condenser across said common coil, or for connecting said second condenser across said common coil with said bass coil shunted out and said first condenser omitted from the circuit, or for connecting said second condenser across said treble coil and shunting out said bass coil with said first condenser omitted from the circuit.

10. An electrical pickup for a musical instrument having magnetizable bass and treble strings comprising a base, an electrical switch, a bass coil positioned flatwise on said base under said bass strings to the exclusion of others of said strings, a common coil positioned flatwise on said base under all said strings, a treble coil positioned flatwise on said base under said treble strings to the exclusion of others of said strings, a first condenser, a second condenser, electrical connections connecting said coils in series and in a direction around said coils whereby the voltages induced in the coils by a magnetized string vibrated thereover are additive, said series connections forming an output circuit, first magnetic means extending above said bass coil and projecting upwardly under each of said bass strings, second magnetic means extending above said common coil and projecting upwardly under each of said strings, third magnetic means extending above said treble coil and projecting upwardly under each of said treble strings, one of said magnetic means being permanently magnetized and the other magnetic means having polarity corresponding to the induced polarity of said one magnetic means, electrical connections between said condensers and said switch and said series circuit for selectively connecting said first condenser across said bass coil with said second condenser across said common coil, or for connecting said second condenser across said common coil with said bass coil shunted out and said first condenser omitted from the circuit, or for connecting said second condenser across said treble coil and shunting out said bass coil with said first condenser omitted from the circuit.

11. An electrical pickup for a stringed musical instrument having magnetizable bass and treble strings comprising a treble coil positioned under said treble strings to the exclusion of said bass strings, a bass coil positioned under said bass strings to the exclusion of said treble strings, a common coil positioned under all said strings, magnets positioned in each coil and projecting upwardly with poles opposed to each string with which the coil is associated, the magnets in the bass and treble coils having the same pole upward and the magnets in the common coil having the opposite pole upward, a pickup circuit connected in series through said coils and in a direction around the coils whereby the voltages induced in the coils by a magnetized string vibrated thereover are additive, a relatively large condenser and a relatively small condenser, and a multi-position switch and electrical connections connected to selectively connect the large condenser across the bass coil with the small condenser connected across the common coil, or small condenser across the common coil with the bass coil shunted out and the large condenser inoperative, or with the small condenser across said treble coil with said bass coil shunted out and said large condenser inoperative, or with said smaller condenser across said treble coil and said larger condenser across said bass coil.

12. An electrical pickup for a stringed musical instrument having magnetizable bass and treble strings comprising a treble coil positioned under said treble strings to the exclusion of said bass strings, a bass coil positioned under said bass strings to the exclusion of said treble strings, a common coil positioned under all said strings, magnets positioned in said common coil and

projecting upwardly with poles opposed to each string, a pickup circuit connected in series through said coils and in a direction around the coils whereby the currents induced in the coils by a string vibrated there-  
 over are additive, a relatively large condenser and a  
 relatively small condenser, and a multi-position switch  
 and electrical connections connected to selectively con-  
 nect the large condenser across the bass coil with the  
 small condenser connected across the common coil, or  
 the small condenser across the common coil with the  
 bass coil shunted out and the large condenser inoper-  
 ative, or with the small condenser across said treble coil  
 with said bass coil shunted out and said large condenser  
 inoperative.

13. An electrical pickup for a stringed musical instru-  
 ment having magnetizable bass and treble strings com-  
 prising a treble coil positioned under said treble strings  
 to the exclusion of said bass strings, a bass coil posi-  
 tioned under said bass strings to the exclusion of said  
 treble strings, a common coil positioned under all said  
 strings and between said bass and treble coils, magnets  
 positioned in each coil and projecting upwardly with  
 poles opposed to each string with which the coil is asso-  
 ciated, the magnets in the bass and treble coils having  
 the same pole upward, a pickup circuit connected in  
 series through said coils and in a direction around the  
 coils whereby the voltages induced in the coils by a  
 string vibrated thereover are additive, a first condenser  
 and a second condenser, and a multi-position switch and  
 electrical connections connected to selectively connect  
 the first condenser across the bass coil with the second  
 condenser across the common coil, or with the second  
 condenser across the common coil with the first coil  
 shunted out and the first condenser inoperative, or with  
 the second condenser across said treble coil with said  
 bass coil shunted out and said first condenser inoperative.

14. An electrical pickup for a stringed musical instru-  
 ment having magnetizable bass and treble strings com-  
 prising a treble coil positioned under said treble strings  
 to the exclusion of said bass strings, a bass coil posi-  
 tioned under said bass strings to the exclusion of said  
 treble strings, a common coil positioned under all said  
 strings and between said bass and treble coils, magnets  
 positioned in each coil and projecting upwardly with poles  
 opposed to each string with which the coil is associated,  
 a pickup circuit connected in series through said coils and  
 in a direction around the coils whereby the voltages in-  
 duced in the coils by a string vibrated thereover are ad-  
 ditive, a first condenser and a second condenser, and a  
 multi-position switch and electrical connections connected  
 to selectively connect the first condenser across the bass  
 coil with the second condenser across the common coil, or  
 with the second condenser across the common coil with  
 the first coil shunted out and the first condenser inoper-  
 ative, or with the second condenser across said treble coil  
 with said bass coil shunted out and said first condenser  
 inoperative.

15. An electrical pickup for a stringed musical instru-  
 ment having bass and treble strings comprising a treble  
 coil positioned under said treble strings to the exclusion  
 of said bass strings, a bass coil positioned under said bass  
 strings to the exclusion of said treble strings, a common  
 coil positioned under all said strings, permanent magnet  
 means positioned to magnetize said strings over said coils  
 with the strings over said common coil polarized oppositely  
 over the common coil from the polarity over the other  
 coils, a pickup circuit connected in series through said  
 coils and in a direction around the coils whereby the  
 voltages induced in the coils by a string vibrated thereover  
 are additive, a first condenser and a second condenser,  
 and a multi-position switch and electrical connections con-  
 nected to selectively connect the first condenser across  
 the bass coil with the second condenser connected across  
 the common coil, or with the second condenser across

the common coil and the bass coil shunted out and with  
 the first condenser inoperative, or with the second con-  
 denser across said treble coil and said bass coil shunted  
 out with said first condenser inoperative.

16. An electrical pickup for a stringed musical instru-  
 ment having magnetizable bass and treble strings com-  
 prising a treble coil positioned under said treble strings  
 to the exclusion of said bass strings, a bass coil posi-  
 tioned under said bass strings to the exclusion of said treble  
 strings, a common coil positioned under all said strings,  
 magnet means positioned to magnetize said strings over  
 said coils with the strings over said common coil polarized  
 oppositely over the common coil from the polarity over  
 the other coils, a pickup circuit connected in series through  
 said coils and in a direction around the coils whereby the  
 voltages induced in the coils by a string vibrated there-  
 over are additive, a first condenser and a second condenser  
 and a multi-position switch and electrical connections  
 connected to selectively connect the first condenser across  
 the bass coil with the second condenser connected across  
 the common coil, or with the second condenser across the  
 common coil with the bass coil shunted out and the first  
 condenser inoperative, or with the second condenser  
 across said treble coil with said bass coil shunted out and  
 said first condenser inoperative.

17. An electrical pickup for a stringed musical instru-  
 ment having magnetizable bass and treble strings com-  
 prising a treble coil positioned under said treble strings  
 to the exclusion of said bass strings, a bass coil posi-  
 tioned under said bass strings to the exclusion of said treble  
 strings and further from the ends of the strings than said  
 treble coil, a common coil positioned under all said strings  
 and between said bass and treble coils, magnetic means  
 common to all said strings positioned to magnetize said  
 strings over said coils, said magnetic means being posi-  
 tioned and polarized to create a magnetic field threading  
 said coils through said common coil in magnetic series  
 with each of said bass coil and said treble coil, a pickup  
 circuit connected in series through said coils, a pair of  
 dissimilar electrical impedances and a multi-position  
 switch and electrical connections connected to selectively  
 connect impedances across different coils and shunt out  
 selected coils in said series circuit, said coils being closely  
 spaced in side by side relation longitudinally along said  
 strings.

18. An electrical pickup for a stringed musical instru-  
 ment having magnetizable bass and treble strings com-  
 prising a treble coil positioned under said treble strings  
 to the exclusion of said bass strings, a bass coil posi-  
 tioned under said bass strings to the exclusion of said treble  
 strings, a common coil positioned under all said strings,  
 magnetic means common to all said strings positioned to  
 magnetize said strings over said coils, a pickup circuit  
 connected in series through said coils, said magnetic  
 means being positioned and polarized to create a magnetic  
 field threading said coils through said common coil in  
 magnetic series with each of said bass coil and said treble  
 coil, a pair of electrical impedances and a multi-position  
 switch and electrical connections connected to selectively  
 connect the impedances across different coils and shunt  
 out selected coils in said series circuit.

19. An electrical pickup for a stringed musical instru-  
 ment having bass and treble strings comprising a treble  
 coil positioned in inductively coupled relation to said  
 treble strings to the exclusion of said bass strings, a bass  
 coil positioned in inductively coupled relation to said bass  
 strings to the exclusion of said treble strings, a common  
 coil positioned in inductively coupled relation to all said  
 strings, magnetic means common to all said strings posi-  
 tioned to magnetize said strings over said coils, said mag-  
 netic means being positioned and polarized to create a  
 magnetic field threading said coils through said common  
 coil in magnetic series with each of said bass coil and  
 said treble coil, a pickup circuit connected in series

11

through said coils, a pair of electrical impedances and a multi-position switch and electrical connections connected to selectively connect the impedances across different coils and shunt out selected coils in said series circuit.

20. An electrical pickup for stringed musical instruments having magnetizable bass and treble strings comprising a common coil positioned in inductively coupled relation under all said strings, a treble coil positioned in inductively coupled relation under said treble strings to the exclusion of said bass strings, a bass coil positioned in inductively coupled relation under said bass strings to the exclusion of said treble strings, a magnetic means in the common coil positioned to magnetize all said strings, a second magnetic means in said bass coil positioned to magnetize the bass strings in aiding relation to the first magnetic means, a third magnetic means in said treble

5

10

15

12

coil positioned to magnetize said treble strings in aiding relation to the first magnetic means, a pickup circuit connected in series through said coils, a pair of electrical impedances, and a multi-position switch connected and arranged to selectively connect the impedances across coils and selectively shunt out selected coils in said series circuit, said coils being closely spaced in adjacent relation longitudinally of said strings.

References Cited in the file of this patent

UNITED STATES PATENTS

2,001,392	Miessner -----	May 14, 1935,
2,573,254	Fender -----	Oct. 30, 1951
2,741,146	Fender -----	Apr. 10, 1956
2,784,631	Fender -----	Mar. 12, 1957