

(19) World Intellectual Property Organization
International Bureau



(43) International Publication Date
2 August 2007 (02.08.2007)

PCT

(10) International Publication Number
WO 2007/087430 A2

- (51) International Patent Classification:
A63F 9/24 (2006.01) A63B 71/00 (2006.01)
- (21) International Application Number:
PCT/US2007/002159
- (22) International Filing Date: 25 January 2007 (25.01.2007)
- (25) Filing Language: English
- (26) Publication Language: English
- (30) Priority Data:
60/761,976 25 January 2006 (25.01.2006) US
- (71) Applicant and
- (72) Inventor: FAITH, William, B. [US/US]; 8837 Shirley Ave., Northridge, CA 91324 (US).
- (74) Agent: JEPPSEN, Jeffrey, R.; River Park Corporate Center One, Rader, Fishman & Grauer PLLC, 10653 South River Front Parkway, Suite 150, South Jordan, UT 84095 (US).
- (81) Designated States (unless otherwise indicated, for every kind of national protection available): AE, AG, AL, AM,

AT, AU, AZ, BA, BB, BG, BR, BW, BY, BZ, CA, CH, CN, CO, CR, CU, CZ, DE, DK, DM, DZ, EC, EE, EG, ES, FI, GB, GD, GE, GH, GM, GT, HN, HR, HU, ID, IL, IN, IS, JP, KE, KG, KM, KN, KP, KR, KZ, LA, LC, LK, LR, LS, LT, LU, LV, LY, MA, MD, MG, MK, MN, MW, MX, MY, MZ, NA, NG, NI, NO, NZ, OM, PG, PH, PL, PT, RO, RS, RU, SC, SD, SE, SG, SK, SL, SM, SV, SY, TJ, TM, TN, TR, TT, TZ, UA, UG, US, UZ, VC, VN, ZA, ZM, ZW.

(84) Designated States (unless otherwise indicated, for every kind of regional protection available): ARIPO (BW, GH, GM, KE, LS, MW, MZ, NA, SD, SL, SZ, TZ, UG, ZM, ZW), Eurasian (AM, AZ, BY, KG, KZ, MD, RU, TJ, TM), European (AT, BE, BG, CH, CY, CZ, DE, DK, EE, ES, FI, FR, GB, GR, HU, IE, IS, IT, LT, LU, LV, MC, NL, PL, PT, RO, SE, SI, SK, TR), OAPI (BF, BJ, CF, CG, CI, CM, GA, GN, GQ, GW, ML, MR, NE, SN, TD, TG).

Published:
— without international search report and to be republished upon receipt of that report

For two-letter codes and other abbreviations, refer to the "Guidance Notes on Codes and Abbreviations" appearing at the beginning of each regular issue of the PCT Gazette.

(54) Title: SPIN MECHANISMS GAME

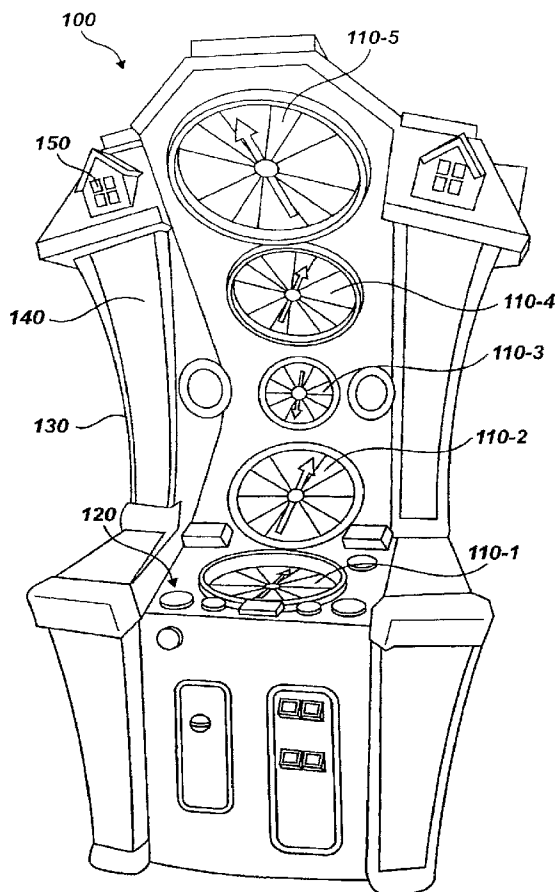

(57) Abstract: An exemplary game apparatus (100) includes a plurality of spin mechanisms (110) including at least a first spin mechanism (110-1) and a second spin mechanism (110-2), and a control unit (224) communicatively connected to the spin mechanisms (110). The control unit (224) is configured to provide a virtual passageway enabling game play to move between the first spin mechanism (110-1) and the second spin mechanism (110-2). In certain implementations, the first spin mechanism (110-1) includes a plurality of landing zones (330), one of the landing zones (330) being associated with the virtual passageway. In certain implementations, the control unit (224) is configured to move game play from the first spin mechanism (110-1) to the second spin mechanism (110-2) in response to a spin action of the first spin mechanism (110-1) stopping at the landing zone (330) associated with the virtual passageway.

WO 2007/087430 A2

SPIN MECHANISMS GAME

RELATED APPLICATIONS

5 **[0001]** The present application claims priority under 35 U.S.C. §119(e) to U.S. Provisional Patent Application No. 60/761,976, by William B. Faith, filed on January 25, 2006, and entitled SPIN MECHANISMS GAME, the contents of which are hereby incorporated by reference in their entirety.

10 BACKGROUND INFORMATION

[0002] One popular type of arcade game is the redemption game. A redemption game is one in which a player is awarded with points, tickets, tokens or other items redeemable for prizes. Some such conventional arcade-style game units include a single spin mechanism having a graphic display and a pointer. To
15 play a conventional single-spinner game, a player typically buys credits and initiates spins of the single spinner. Points or other rewards are awarded according to the position on the graphic display where the pointer comes to rest after a spin. The player accumulates points by repeatedly initiating spins of the same spin mechanism.

20 **[0003]** Such single-spinner games provide very limited amusement quality to players because the games are capable of producing only limited possibilities and outcomes. Moreover, the outcomes are generally random and do not involve the skill of the player. Accordingly, conventional single-spinner games usually fail to entice an average player into playing more than a few times.

25

BRIEF DESCRIPTION OF THE DRAWINGS

[0004] The accompanying drawings illustrate various exemplary implementations and are a part of the specification. The illustrated implementations are merely examples and do not limit the scope of the
30 disclosure. Throughout the drawings, identical reference numbers designate identical or similar elements.

[0005] Figure 1 is a perspective view of an exemplary game apparatus.

[0006] Figure 2 is a block diagram of exemplary components of the game apparatus of Figure 1.

[0007] Figure 3 illustrates a front view of an exemplary spin mechanism of the game apparatus of Figure 1.

5 [0008] Figure 4 is a rear view of the exemplary spin mechanism of Figure 3.

[0009] Figure 5 is a front view of the exemplary spin mechanism of Figure 3 with the face plate removed.

10 [0010] Figure 6 illustrates an exemplary position encoder and reader that may be utilized by the spin mechanism of Figure 3.

[0011] Figure 7 is a flowchart illustrating an exemplary process for moving game play from one spin mechanism to another spin mechanism.

[0012] Figure 8 is a flowchart illustrating an exemplary process for obtaining credit.

15 [0013] Figures 9A-B illustrate an exemplary spin process for a first spin mechanism.

[0014] Figures 10A-B illustrate an exemplary spin process for a second spin mechanism.

20 [0015] Figures 11A-B illustrate an exemplary spin process for a third spin mechanism.

[0016] Figures 12A-B illustrate an exemplary spin process for a fourth spin mechanism.

[0017] Figures 13A-B illustrate an exemplary spin process for a fifth spin mechanism.

25

DETAILED DESCRIPTION

I. INTRODUCTION

[0018] Exemplary implementations include game apparatuses comprising a plurality of spin mechanisms. The spin mechanisms of such a game apparatus may be associated with rewards, and a user of the game apparatus may attempt to obtain rewards by initiating successive spin actions of one or more of the spin mechanisms. For example, each of the spin mechanisms

30

may be associated with a different set of rewards corresponding to a set of landing positions. When a spin action stops at a particular landing position, one or more corresponding actions may be performed, such as awarding the user with the corresponding reward. As used herein, the term "rewards" may refer to points, tickets, tokens, credits, credit refunds, coins, currency, prizes, game actions (e.g., movements of game play between the multiple spin mechanisms, bonus spin actions), any suitable consequences of a spin action as may suit a particular application, or any combination thereof.

[0019] A game apparatus may be configured to move game play between multiple spin mechanisms based on spin actions performed by the spin mechanisms. For example, game play may begin at a first spin mechanism. A spin action of the first spin mechanism may be initiated and stopped. When the spin action stops at a landing position associated with a virtual passageway to a second spin mechanism, game play may be moved to the second spin mechanism. In this or similar manner, one or more virtual passageways between various spin mechanisms may be defined and may provide numerous game play possibilities and outcomes to a user of a game apparatus.

[0020] For example, a game apparatus may include multiple spin mechanisms arranged in a hierarchy in which each of the spin mechanisms is associated with a level of the hierarchy. Game play may begin at a first spin mechanism in the hierarchy. A user may attempt to stop spin actions on virtual passageway landing positions that will allow game play to advance to other spin mechanisms in the hierarchy. As game play advances further along the hierarchy, the value of potential rewards may increase. The potential for high value rewards may entice users to provide credits for repeated game play. The various possibilities and outcomes of game play coupled with the potential to earn high value rewards may attract users to repeatedly play a game apparatus. These and other features and benefits of exemplary game apparatuses will now be described in relation to the Figures.

II. EXEMPLARY APPARATUS VIEWS

[0021] Figure 1 illustrates an exemplary game apparatus 100. As shown in Figure 1, game apparatus 100 may include a plurality of spin mechanisms 110-1 through 110-5 (collectively "spin mechanisms 110"). The number of spin mechanisms shown in Figure 1 is exemplary only. The plurality of spin mechanisms 110 may include two or more spin mechanisms (e.g., spin mechanisms 110-1 through 110-N). As described further below, the game apparatus 100 may provide one or more virtual passageways between the spin mechanisms 110.

[0022] The game apparatus 100 may also include controls 120 enabling a user of the game apparatus 100 to control at least some of its operations, including controlling game play such as spin actions of the spin mechanisms 110. The controls 120 and spin mechanisms 110 may be configured to enable the user to participate in a game experience that allows the user to attempt to obtain rewards by spinning one or more of the spin mechanisms 110, as described below.

[0023] The spin mechanisms 110 and controls 120 may be housed in a cabinet 130. The cabinet 130 shown in Figure 1 is exemplary only. The cabinet 130 may include any suitable support structure(s) capable of housing the spin mechanisms 110 and controls 120. The cabinet 130 may comprise any suitable material(s), including metal, fiberglass, glass, wood, plastic, etc.

[0024] The cabinet 130 may include one or more structural components. In certain implementations, all of the spin mechanisms 110 may be housed in a single support structure. In other implementations, more than one structure may be used to house the spin mechanisms 110. For example, the cabinet 130 may include a base unit 140 housing spin mechanisms 110-1 through 110-4 and an expansion unit 150 housing spin mechanism 110-5. The expansion unit 150 may be permanently or removably attached to the base unit 140 in any suitable manner.

[0025] The game apparatus 100 shown in Figure 1 is illustrative only and not restrictive in any sense. Various implementations may include different configurations of spin mechanisms. In certain alternative implementations, game

apparatuses may be configured for concurrent play by multiple users (i.e., multi-player game apparatuses). For example, a two-player game apparatus may include two sets of multiple spin mechanisms. The two sets may be positioned adjacent to one another. A three-player game apparatus may include three sets of multiple spin mechanisms, and so on. In certain implementations, at least one of the spin mechanisms is configured to be shared between multiple players.

[0026] Figure 2 is a block diagram of exemplary components of the game apparatus 100. As shown in Figure 2, the spin mechanisms 110-1 through 110-5 may be included in a spin assembly 210 and the controls 120 may be included in a console assembly 220. Components of the spin assembly 210 and console assembly 220 may be communicatively connected to a control unit 224, which may include at least one processor 226 and memory unit 228. The processor 226 may control operations of the spin mechanisms 110 and controls 120 as directed by instructions (e.g., software and/or firmware) stored in the memory unit 228. The instructions may be configured to direct the processor 226 to perform, initiate, or control any of the processes described herein.

[0027] Accordingly, the processes described herein may be implemented at least in part as instructions executable by one or more computing devices (processor 226), as is well known. In general, processor 226 receives instructions, e.g., from memory unit 228, a computer-readable medium, input mechanism, etc., and executes those instructions, thereby performing one or more processes, including one or more of the processes described herein. Such instructions may be stored and transmitted using a variety of known computer-readable media.

[0028] The exemplary components illustrated in Figure 2 are not intended to be limiting. Other alternative hardware environments and implementations may be used. The components of the game apparatus 100 may communicate using any suitable communication technologies, including well-known electronic communication technologies such as a data bus 229.

[0029] The controls 120 in the console assembly 220 may include one or more mechanisms for receiving input from and providing output to a user of the game apparatus 100. The controls 120 may include any suitable mechanisms,

including, but not limited to, switches, displays, LEDs, illuminators (e.g., neon lights), keypads, and any combinations thereof. Exemplary controls 120 may include a credit acceptor 230, credit indicator 235, insert credit indicator 240, a start spin control 245, a spin speed indicator 250, a score indicator 255, a slow stop spin control 260, a quick stop spin control 265, an advance level control 270, and a reward dispenser 275.

[0030] Credit acceptor 230 may be configured to accept one or more suitable forms of credit from a user of the game apparatus 100, including, but not limited to, currency (e.g., coins and/or bills), tokens, vouchers, and electronic credit (e.g., by a swipe of card), for example. In certain implementations, the game apparatus 100 may be configured to allow the user to participate in a game experience when at least a predetermined credit amount has been received.

[0031] The game apparatus 100 may be configured to hold received and unused credit in escrow. Credit received from a user may be added to the escrow, and credit may be subtracted from the escrow when certain predefined game events occur. In certain implementations, credit held in escrow or at least a subset of the credit received during a game session may be refunded to the user when a certain predefined game event occurs, such as a spin action of a spin mechanism 110 landing on a predetermined "refund" landing position, as described below.

[0032] Credit indicator 235 may be configured to indicate (e.g., display) the current amount of unused credit that has been received. Credit may be depleted during game play. For example, a spin of a spin mechanism 110 and/or a level advancement (e.g., from one spin mechanism 110 to another) may cost one or more units of credit. The amount of credit charged and the particular actions for which credit will be charged may vary for different implementations and may be configurable by an operator and/or manufacturer. Accordingly, credit charges may be customized as may suit a particular application. In certain implementations, for example, credit may be charged for certain level advancements (e.g., movements between spin mechanisms by certain progressive virtual passageways) but not for other level advancements (e.g., movements between spin mechanisms by progressive "bonus" or regressive

virtual passageways). An operator may choose whether to charge and/or the credit amounts to be charged for level advancements and configure the game apparatus 100 accordingly.

[0033] In some examples, costs of game play may vary based on one or more predefined factors. For example, the cost of a game play action (e.g., a spin action or a level advancement) may be less expensive when the game apparatus 100 has received at least predetermined amount of credit. For instance, a deposit of one credit may earn one game play action and a deposit of two credits may earn three game play actions.

[0034] When credit is exhausted, game play may be terminated or suspended, and the game apparatus 100 may request that additional credit be provided. For example, the insert credit indicator 240 may signal the user to provide credit, such as by flashing a light to illuminate the insert credit indicator 240. The game apparatus 100 may allow a predefined period of time within which the user may provide sufficient credit to continue a game session. Once the time period expires without sufficient credit being provided, the game session may be terminated.

[0035] In certain implementations, the game apparatus 100 may be configured to allow a user to advance game play to a specific spin mechanism 110 by providing a predetermined amount of credit. For example, a user may begin a game session by providing one unit of credit and actuating the advance level control 270. As a result, game play will begin at the first spin mechanism 110-1, i.e., the first spin mechanism 110-1 will be activated for game play. However, the user may advance game play directly to another spin mechanism 110 by providing a predetermined amount of credit and utilizing the advance level control 270. In some implementations, for instance, four credit units may enable a jump to the second spin mechanism 110-2, eight credit units may enable a jump to the fourth spin mechanism 110-4, and fifteen credit units may enable a jump to the fifth spin mechanism 110-5. Of course, the predetermined amounts of credit may vary and/or may be adjustable by an operator of the game apparatus 100.

[0036] In certain implementations, game apparatus 100 may include start spin control 245, slow stop spin control 260, quick stop spin control 265, and advance level control 270, which may enable a user to control game play. During an exemplary mode of play, for example, one of the spin mechanisms 110 is typically active and controllable by the user. Game play may be said to be activated at a game level associated with the active spin mechanism 110. For instance, the user may begin play at a first level associated with spin mechanism 110-1, i.e., spin mechanism 110-1 is activated for game play. In certain implementations or game situations, a spin of spin mechanism 110-1 may be initiated automatically by the control unit 224. In other implementations or game situations, the user may utilize the start spin control 245 to initiate a spin of the spin mechanism 110-1. The spin speed indicator 250 may be configured to indicate the speed of the spin action to the user. For example, the spin speed indicator 250 may display the spin speed in revolutions per minute ("RPM"). The speed may be determined in any acceptable manner.

[0037] The user may utilize the slow stop spin control 260, the quick stop spin control 265, or a combination of spin controls 260 and 265 to stop the spin action of spin mechanism 110-1. In certain examples, the slow stop spin control 260 and quick stop spin control 265 become active once the spin speed reaches a predetermined threshold (e.g., a predetermined speed). This can prevent users from undesirably manipulating game play by stopping a spin action before a desirable spin speed has been reached. Actuation of the slow stop spin control 260 may instruct the game apparatus 110 to stop providing power to spin mechanism 110-1, thereby allowing the spin to slowly decelerate until stopped. Actuation of the quick stop spin control 265 may instruct the game apparatus 110 to stop providing power and to apply a brake to spin mechanism 110-1, thereby causing the spin action to quickly decelerate until stopped.

[0038] While certain implementations may provide a user with control over stopping spin actions, other implementations may stop spin actions in other ways. In some implementations, for example, the game apparatus 100 may be configured to allow a spin action to come to a stop in a random manner. This may be done using any known random number generator, which may be used to

randomly determine the period of time power is applied to a spin mechanism 110. In other implementations, for example, the game apparatus 100 may include logic configured to control the stopping positions of spin actions. This may be performed using a servo motor, for example. The stopping position of the servo
5 motor may or may not be selected randomly.

[0039] In certain implementations, the game apparatus 100 may be configured to automatically cause a spin action to stop after a predetermined length of time. For example, power may be applied to the spin mechanism 110 for no longer than the predetermined length of time, or power to the spin
10 mechanism may be terminated at a predetermined length of time after the spin action reaches a predetermined threshold speed. Components of an exemplary spin mechanism 110 will be described in detail further below.

[0040] The spin mechanism 110-1 may be configured such that a spin action will come to a stop at one of a plurality of possible landing positions. The game apparatus 100 may be configured to determine the stop position and
15 perform at least one action that is associated with the position. As described in more detail below, examples of actions that may be associated with spin landing positions may include, but are not limited to, providing at least one reward, as defined above. Accordingly, predefined actions may include, but are not limited
20 to, awarding points to the user, advancing play to another level, i.e., to another spin mechanism such as spin mechanism 110-2 (e.g., spin mechanism 110-2 becomes active and controllable by the user), reverting game play to another level, i.e., to another spin mechanism, and ending or suspending play. Any of the actions may be made conditional on the user having already provided or
25 providing a predetermined amount of credit, as described above.

[0041] By controlling spin actions of the spin mechanisms 110, a user of the game apparatus 110 can attempt to accumulate rewards during game play. Each of the spin mechanisms 110 may include a plurality of landing positions associated with a predefined set of rewards. When a spin stops at a landing
30 position, the associated reward(s) is/are awarded and/or performed. Through successive spins of various spin mechanisms 110, the user can accumulate rewards. The reward dispenser 275 may provide rewards to the user when

predetermined reward thresholds are satisfied and/or at the end of a game session. The rewards may be in various forms, including tickets, vouchers, or other items that may be redeemable for prizes, for example.

[0042] The amount and type of rewards may be configurable by a manufacturer and/or an operator of the game apparatus 100. In certain implementations, the game apparatus 100 is configured to add points to an accumulative score total. The score indicator 255 may indicate to the user the amount of accumulated points. At the end of a game session, the points may be converted to tickets, which can be dispensed to a user by the reward dispenser 275. Of course, other implementations may utilize different reward options. For instance, some implementations may dispense tickets for each spin that stops at a landing position associated with tickets. In certain implementations, the game apparatus 100 may be configured to provide the user with an option of accepting a reward or foregoing the reward for an alternative reward. For example, a user may be provided with an option of accepting points or foregoing points (or other reward) for an additional spin action. The values of available rewards may be temporarily increased for the bonus spin action. The bonus spin action may be performed at the same level (i.e., same spin mechanism 110) or at another level (i.e., another spin mechanism 110).

[0043] As mentioned previously, the game apparatus 100 (e.g., the control unit 224) may be configured to provide one or more virtual passageways between spin mechanisms 110 such that game play can move between the spin mechanisms 110 based on the results of spin actions. For example, when game play is at a first level associated with a first spin mechanism 110-1 (e.g., spin mechanism 110-1 is active), a user may start and stop a spin action of the spin mechanism 110-1, as described above. One of the landing positions may be associated with a particular virtual passageway to the second spin mechanism 110-2, and when the spin action stops at this particular landing position, the game apparatus 110 (e.g., the control unit 224) may move game play to the second spin mechanism 110-2 (e.g., spin mechanism 110-2 is activated and spin mechanism 110-1 deactivated). The user may then control spin actions of the second spin mechanism 110-2.

[0044] This is just one example of a virtual passageway. Other virtual passageways between the various spin mechanisms 110 may also be provided and function in similar fashion. For example, one of the landing positions of the second spin mechanism 110-2 may be associated with a regressive type virtual passageway (e.g., a "booby trap") back to the first spin mechanism 110-1.

[0045] The spin mechanisms 110 may be arranged to form hierarchical levels of play through which a user can attempt to advance in order to maximize the rewards that can be earned. For example, spin mechanisms 110-1 and 110-2 may be arranged hierarchically such that game play normally begins at spin mechanism 110-1, which includes a plurality of landing positions associated with a first set of rewards. A spin of spin mechanism 110-1 may result in any reward included the first set of rewards.

[0046] This first set of rewards may have relatively less value as compared to rewards that can be obtained from a spin of the second spin mechanisms 110-2. Accordingly, it may be desirable to advance game play from the first spin mechanism 110-1 to the second spin mechanism 110-1 so that the relatively more valuable rewards can be obtained. Accordingly, the first and second spin mechanisms 110-1 and 110-2 may be described as forming a hierarchy of spin mechanisms 110 having at least one virtual passageway between them. Of course, other hierarchies may include more than two spin mechanisms 110. In the game apparatus 100 of Figure 1, spin mechanisms 110-1 through 110-5 may form a hierarchy. In certain implementations, the value of available rewards is configured to increase as game play moves toward spin mechanism 110-5 and to decrease as game play moves toward spin mechanism 110-1.

[0047] Game play including potential for virtual movement between multiple spin mechanisms 110 can provide improved excitement and quality of play as compared to conventional single-spinner arcade games. By way of comparison, multiple spin mechanisms 110 having virtual passageways between them can provide a significant increase in the number of possible outcomes. In addition, relatively higher value rewards can be made available at least because the game apparatus 110 can require a considerable amount of skill, play, luck,

and/or credit before game play is advanced to a level at which the higher value rewards may be obtained. For at least these reasons, the game apparatus 100 may attract more traffic in terms of both quantity and quality as compared to conventional single-spinner arcade games.

5 **[0048]** Figure 3 illustrates a front view of an exemplary spin mechanism 110. As shown in Figure 3, the spin mechanism 110 may include a pointer 310 and face plate 320. The pointer 310 may be rotated about the face plate 320, which action may be referred to as a "spin" or "spin action" of the spin mechanism 110.

10 **[0049]** The face plate 320 may include a graphic display illustrating a plurality of landing zones 330-1 through 330-N (collectively "landing zones 330"). Each of the landing zones 330 may occupy a predetermined area of the face plate 320. In certain implementations, the number and/or areas of the landing zones 330 may be configurable by an operator of the game apparatus 100. For
15 example, the area of a particular landing zone 330 may be reduced to reduce the chances of the pointer 310 stopping in that landing zone 330. This capability of configuring the landing zones 330 may enable an operator to control the odds of a spin stopping at a particular landing zone 330, and thus the odds of a user obtaining rewards associated with the landing zones 330. In certain
20 implementations, the game apparatus 100 enables the operator to specify a target winning percentage and adjusts the size of the landing zones 330 based on the target winning percentage.

[0050] In some examples, the landing zones 330 and/or the graphic display illustrating the landing zones 330 may be adjusted by the processor 226
25 based on changes to software, firmware, or other instructions included in the memory unit 228. In other examples, the graphic display is an interchangeable element that may be attached to and removed from the face plate 320.

[0051] Odds of winning rewards may be adjustable in other ways. In certain alternative implementations, for example, the control unit 224 may be
30 configured to perform a micro-adjustment to the pointer 310 as it comes to rest at a stop position. The micro-adjustment may be determined based on a current

winning percentage as compared a target winning percentage. Based on these factors, the micro-adjustment may be favorable or unfavorable to a user.

[0052] Each of the landing zones 330 may be associated with one or more rewards, including, but not limited to, any of the rewards listed above. In Figure 3, landing zone 330-1 is associated with a predefined virtual passageway to another spin mechanism 110. In this case, the virtual passageway is a "single level advancement" (i.e., an "advance one level" passageway) to another spin mechanism 110, which may in general offer more desirable rewards (e.g. larger point amounts) as compared to the current spin mechanism 110. In addition to the level advancement action, points or other rewards may or may not be awarded when a spin stops at landing zone 330-1. As mentioned, the game apparatus 100 may or may not charge one or more credits for the level advancement.

[0053] Landing zone 330-7 is associated with another predefined virtual passageway to yet another spin mechanism 110. In this case, the virtual passageway is a "single level regression" (i.e., a "back up one level" passageway) to either another spin mechanism 110, which in general offers less desirable rewards (e.g., smaller point amounts), or to a termination of a game session when the current spin mechanism 110 is associated with the lowest level of the game.

[0054] Landing zones 330-5 and 330-9 are associated with additional, respective virtual passageways to yet other spin mechanisms 110. The virtual passageways may be to any pre-selected spin mechanisms 110 and may be referred to a "secret passageways." In an exemplary implementation, the spin mechanism 110 shown in Figure 3 is spin mechanism 110-3, and the virtual passageway associated with landing zone 330-5 is to spin mechanism 110-5 and the virtual passageway associated with landing zone 330-9 is to spin mechanism 110-4. In addition to the level advancement action, points or other rewards may or may not be awarded when a spin stops at landing zone 330-5 or 330-9. Again, the game apparatus 100 may or may not charge one or more credits for the level advancement.

[0055] The remaining landing zones 330, i.e., landing zones 330-2 through 330-4, 330-6, 330-8, and 330-10 through 330-N, may be associated with various point amounts. When a spin stops at any one of these landing zones, which may be referred to as "points only" landing zones or "points positions," the corresponding points may be awarded and the game session ended. In certain situations, instead of ending the game session, the game apparatus 100 may provide the user with an option to accept the points and end the game or forego the points for another spin.

[0056] The landing zones 330 in Figure 3 are associated with a particular set of rewards that may be obtained by spinning the pointer 310. This exemplary set of rewards is not limiting; any suitable set of rewards may be used. In certain implementations, each spin mechanism 110 is associated with a different set of rewards. The landing zones 330 and corresponding rewards may be configurable, such as by an operator changing the graphic display and software stored in the memory unit 228. Modifications and variations may include changing the number of landing zones 330, the sizes of the landing zones 330, the rewards associated with the landing zones 330, the position of the landing zones 330 in relation to one another, associated different rewards with the landing zones 330, and any other suitable changes. In certain alternative implementations, for example, one or more of the landing zones 330 may be associated with a "refund" landing zone 330. When a spin action stops on a "refund" landing zone, credits held in escrow, or at least a subset of the credits received during a game session, may be refunded to the user. For instance, the reward dispenser 275 or the credit acceptor 230 may refund credits (e.g., coins or tokens) to the user.

[0057] A spin action of a spin mechanism 110 may be performed in any suitable manner, including causing pointer 310 to rotate about the face plate 320.

[0058] Figure 4 is a rear view of the exemplary spin mechanism 110 shown in Figure 3. As shown in Figure 4, the spin mechanism 110 may include a frame 410 providing mechanical support for other components of the spin mechanism 110, including the face plate 320 and a spin motor 420. The frame 410 may be connected directly or indirectly to the cabinet 130 and may include

any suitable material(s) and be configured in any form capable of supporting the other elements of the spin mechanism 110. The spin motor 420 may include any motor and/or other mechanism capable of causing the pointer 310 to rotate in relation to the face plate 320. Examples of motors that may be used include, but
5 are not limited to, DC spindle motors, AC spindle motors, DC brush motors, DC brushless motor with a clutch for smooth stopping, and a stepper motor.

[0059] As shown in Figure 4, the spin mechanism 110 may also include circuitry 430 for interfacing with the control unit 224 and controlling components and functions of the spin mechanism 110. For example, the circuitry 430 may be
10 connected to the spin motor 420 for generating rotational motion (e.g., by providing electrically power) and to a solenoid 435 for controlling a brake assembly such as the brake assembly shown in Figure 5.

[0060] As shown in Figure 4, the spin mechanism 110 may also include a position reader 440. As described further below, the position reader 440 may
15 be configured to determine the position at which a spin action stopped (e.g., in which landing zone 330 the pointer 310 came to rest).

[0061] Figure 5 is a front view of the exemplary spin mechanism 110 of Figure 3 with the face plate 320 removed. As shown in Figure 5, the spin mechanism 110 may include flywheel 510, which may be attached to a shaft (not
20 shown) of the spin motor 420. The spin motor 420 and shaft may be configured to cause the flywheel 510 to rotate concurrently with the pointer 310. The flywheel 510 may facilitate a smooth rotational motion (i.e., spin action).

[0062] The flywheel 510 may also be used to stop a spin action. For example, a brake assembly 520 may be configured to engage the flywheel 510.
25 As shown in Figure 5, the spin mechanism 110 may include an exemplary brake assembly 520 having a brake pad 530 and a brake lever 540. The brake pad 530 may include any material suitable for applying sufficient friction to the flywheel 510 to abruptly stop a spin action. For example, the brake pad 530 may include one or more rubber pads reinforced by one or more metal (e.g., steel) plates.

[0063] Movement of the brake lever 540 may cause the brake pad 530
30 to engage the flywheel 510. This may be performed in any suitable manner, including energizing solenoid 435 (see Figure 4), which may be attached to and

cause the brake lever 540 to translate. Application of the brake pad 530 to the flywheel 510 causes the spin motor 420, flywheel 510, and pointer 310 to come to an abrupt stop, thereby stopping the spin action. The brake assembly 520 may include a bias spring (not shown) configured to move the brake pad 530
5 away from the flywheel 510 when the solenoid is not energized. The brake assembly 520 shown in Figure 5 is illustrative only. Other brake assemblies having differently configured elements may be employed for stopping spin actions of the spin mechanism 110.

[0064] The brake pad 530 may be applied in response to any
10 predefined event, including a user actuating the quick stop spin control 265, the pointer 310 coming to a stop (e.g., decelerating to zero speed), or some other event. When the quick stop spin control 265 is actuated, the control unit 224 of the game apparatus 100 may detect a signal representative of the actuation and instruct the brake assembly 520 to apply the brake pad 530 to the flywheel 510.
15 The brake pad 530 may disengage the flywheel 510 in preparation for a spin action (e.g., in response to a user actuating the start spin control 245) or when the particular spin mechanism 110 is inactive.

[0065] The spin mechanism 110 may use any suitable technologies for determining a post-spin landing position (e.g., the landing position of the pointer
20 310). In certain implementations, a position encoder and reader are employed. Figure 5 illustrates the back side of an exemplary position encoder 550 that may be configured to rotate concurrently with the flywheel 510. When the position encoder 550 comes to a stop after a spin, position reader 440 may determine the stop position of the position encoder 550. From this determination, the control
25 unit 224 and/or the spin mechanism 110 may determine at which landing zone 330 the pointer 310 has stopped.

[0066] Figure 6 illustrates an exemplary front side of position encoder 550 along with position reader 440. In this particular example, the position encoder 550 comprises an encoded wheel. As shown, the position encoder 550
30 may include reflective and non-reflective light surfaces arranged such that they can be used to determine the stop position of the position encoder 550 and consequently the pointer 310. The markings on the position encoder 550 may be

configured to represent angular positions. In the example shown in Figure 6, the position encoder 550 is partitioned into two-hundred fifty six (256) segments over three-hundred sixty (360) degrees of surface. Each segment may be identified by an encoded pattern printed on the position encoder 550, and the encoded pattern may include a combination of light reflective and non-reflective surfaces. While the illustrated example includes particular encoded patterns, other implementations may utilize different encodings, including patterns for more segments (finer resolution), less segments (lower resolution), or segments that cover only part of the position encoder 550.

[0067] The position reader 440 may be configured to read the stop position of the position encoder 550. Any suitable technologies may be used to take the reading. In certain implementations, for example, the position reader 440 may include one or more optical light transceivers (e.g., nine individual transceiver modules). The transceivers may be configured to emit light toward the position encoder 550 and sense light is reflected back. Based on whether there is a presence or lack of reflective light, the position reader 440 can send corresponding signals (e.g., different voltage or current levels) to the control unit 224, which may be configured to utilize the signals to determine the position of the position encoder 440 and the pointer 310.

[0068] The game apparatus 100 may be configured to provide skilled and/or unskilled game play. For example, the game apparatus 100 may be selectively configured to operate in a skilled or unskilled mode. Skilled game play may enable a user to control spin actions, or at least the stopping of spin actions, such as by using the slow stop spin control 260 or the quick stop spin control 265 to cause a spin action to stop. In unskilled game play, the control unit 224 may control spin actions, including the positions at which spin actions stop. This may include full-fledged control of spin actions or micro-adjustments to the stop positions of spin actions. The control unit 224 may determine stop positions and/or micro-adjustments based at least in part on a predefined target winning percentage as compared to the current winning percentage.

III. EXEMPLARY PROCESS VIEW

[0069] With the above-described components and configurations, the game apparatus 100 can be configured to provide users with a wide variety of game play experiences and outcomes. In addition, an operator of the game apparatus 100 can configure various features (e.g., credit amounts, user winning percentages, and reward values) as may suit a particular application.

[0070] In general, the game apparatus 100 provides a game experience that allows a user to attempt to advance game play between multiple spin mechanisms 110 in hopes of obtaining rewards and maximizing the potential rewards that can be obtained. In certain implementations, multiple spin mechanisms 110 are arranged to form a hierarchy. During game play, game play can move between the spin mechanisms 110, and therefore between levels of the hierarchy, as spin actions stop on virtual passageways between the spin mechanisms 110.

[0071] Figure 7 is a flowchart illustrating an exemplary process for moving game play from one spin mechanism 110 to another. During game play, a particular spin mechanism 110 may be active. In step 710, a spin action of the spin mechanism 110 may be initiated. Step 710 may be performed in any of the ways and in response to any of the events described above, including control unit 224 providing power (e.g., current) to spin motor 420 when brake pad 530 is disengaged from flywheel 510. The spin action may be initiated automatically (e.g., when the spin mechanism 110 becomes active), in response to a user actuating the start spin control 245, or in response to any other detectable event.

[0072] In step 720, the spin action of the spin mechanism 110 may be stopped. Step 720 may be performed in any of the ways and in response to any of the events described above, including turning off power to the spin motor 420 and/or applying brake pad 530 to the flywheel 510. The spin action may be stopped under the control of the control unit 224 or in response to a user actuating the slow spin stop control 260 and/or the quick stop spin control 265, or in response to any other detectable event.

[0073] In step 730, the stop position is determined. Step 730 may be performed in any of the ways described above, including the position reader 440

reading a pattern of the position encoder 550, and the control unit 224 using one or more signals representative of the reading to identify the stop position of the pointer 310 in relation to the landing zones 330.

5 **[0074]** In step 740, the control unit 224 determines whether the stop position is associated with a virtual passageway. If it is determined that the stop position is associated with a virtual passageway, processing continues to step 750.

10 **[0075]** In step 750, game play is moved to another spin mechanism 110 that is associated with the virtual passageway. Step 750 may be performed in any of the ways described above, including deactivating the origin spin mechanism 110 and activating the target spin mechanism 110. The process of Figure 7 may be repeated for a spin action of the target spin mechanism 110.

15 **[0076]** If it is determined at step 740 that the stop position is not associated with a virtual passageway, the process continues to step 760. In step 760, some other action associated with the stop position is performed. This action may include providing any of the rewards described above, including awarding points, additional spins of the spin mechanism 110, and terminating a game session.

20 **[0077]** Figures 8-13B illustrate exemplary game play processes for an exemplary configuration of five spin mechanisms 110-1 through 110-5 and virtual passageways between the spin mechanisms 110-1 through 110-5. The exemplary processes are illustrative only. Other implementations may omit, add to, reorder, and/or modify any of the steps shown in Figures 8-13B. Accordingly, other processes may be employed for the same configuration of the spin mechanisms 110-1 through 110-5. Moreover, other configurations of two or more spin mechanisms 110 and various game play processes may be employed in other implementations.

25 **[0078]** Figure 8 is a flowchart illustrating an exemplary process for obtaining credit. The process of Figure 8 may be a standalone process or a subroutine that can be called by other processes such as the exemplary processes of Figures 9A-13B. In certain implementations, the process of Figure

30

8 may be repeatedly performed to attract potential users to provide credit and participate in a game experience.

[0079] The process may begin at step 810. In step 810, credit is solicited. This may be performed in any of the ways described above, including
5 illuminating and/or flashing the insert credit indicator 240 and/or the advance level control 270.

[0080] In step 820, the control unit 224 determines whether sufficient credit is available. Step 820 may include determining whether received, unused credit is equal to or greater than a predetermined threshold. If it is determined
10 that sufficient credit is not available, the process will continue at step 830.

[0081] In step 830, it is determined whether credit is received. Step 830 may include monitoring the credit acceptor 230 or otherwise waiting for credit to be provided for a predetermined length of time. If credit is not received within the time period, credit will continue to be solicited at step 810.

[0082] If credit is received within the time period, processing will
15 continue at step 840. In step 840, the received credit is added to the credit total. Processing then continues at step 850.

[0083] If it is determined that sufficient credit is available at step 820, processing moves directly from step 820 to step 850 without steps 830 and 840
20 being performed.

[0084] In step 850, it is determined whether the advance level control 270 is actuated. If actuation of the control 270 is not detected within a predetermined time period, processing may continue at step 810. On the other hand, if actuation of the control 270 is detected, processing will continue at step
25 860.

[0085] In step 860, an appropriate amount of credit (corresponding to an associated action) is subtracted from the credit total. The subroutine process of Figure 8 is then exited, and control is returned to the calling process. Where the process of Figure 8 is executed to attract a user to begin a game, processing
30 may move from step 860 to the process illustrated in Figures 9A-B (see step 910 at "A1" in Figure 9A). In some implementations, processing may move from step 860 directly to step 1010, 1110, 1210, or 1310 in any of the processes in the

respective Figures 10A, 11A, 12A, or 13A in response to a user providing sufficient credit to enable, and appropriate input to initiate, a jump to different game play levels (i.e., different spin mechanisms 110). The process of Figures 9A-B may be performed when game play is at a first level associated with spin mechanism 110-1 (i.e., spin mechanism 110-1 is active), the process of Figures 10A-B may be performed when game play is at a second level associated with spin mechanism 110-2, the process of Figures 11A-B may be performed when game play is at a third level associated with spin mechanism 110-3, the process of Figures 12A-B may be performed when game play is at a fourth level associated with spin mechanism 110-4, and the process of Figures 13A-B may be performed when game play is at a fifth level associated with spin mechanism 110-5.

[0086] Figures 9A-B illustrate an exemplary spin process for the first spin mechanism 110-1. The process may begin at step 910. The beginning of the process at step 910 is represented as "A1" in Figure 9A. In step 910, a spin action of the first spin mechanism 110-1 is initiated. Step 910 may be performed in any of the ways and in response to any of the events described herein.

[0087] In step 920, it is determined whether a threshold speed has been reached. If not, processing loops at step 920 until the threshold speed is determined to have been reached, at which point processing moves to step 925.

[0088] In step 925, it is determined whether the slow stop spin control 260 has been actuated. If it has, power to the first spin mechanism 110-1 is terminated at step 930. As described above, this may allow the spin action to slowly come to a stop. Processing moves from step 930 to step 935.

[0089] If it is determined at step 925 that the slow stop spin control 260 has not been actuated, processing moves directly from step 925 to step 935, bypassing step 930.

[0090] In step 935, it is determined whether the quick stop spin control 265 has been actuated. If it has, power to the first spin mechanism 110-1 is terminated at step 940 and a brake (e.g., brake pad 530) is applied to abruptly stop the spin action of the first spin mechanism 110-1 at step 945. Processing moves from step 945 to step 950.

[0091] If it is determined at step 935 that the quick stop spin control 265 has not been actuated, processing moves directly from step 935 to step 950, bypassing steps 940 and 945.

[0092] In step 950, it is determined whether the spin action has
5 stopped. Step 950 may be performed in any of the ways described above, including determining whether the spin speed is approximately zero. If the spin action has not stopped, processing continues at step 925, as shown. If the spin action has stopped, processing continues at step 955 shown in Figure 9B. "A2," as shown in Figures 9A-B indicates the transition from step 950 to step 955. In
10 some implementations, if the brake is not already applied when the spin action comes to a stop, the brake may be applied to secure the stop position.

[0093] In step 955, it is determined whether the spin action stopped at a "points" position. A "points" position may include any landing zone 330 associated only with points (or some other form of reward) but not with a virtual
15 passageway. Landing zones 330-2 through 330-4, 330-6, 330-8, and 330-10 through 330-12 of Figure 3 may be defined as "points" positions.

[0094] If it is determined that the spin action stopped at a "points" position, processing moves to step 960. In step 960, the points associated with the stop position are added to the point total. The game then ends at step 965.
20 Of course, this is illustrative. In other implementations, other options and/or actions may be performed when a spin stops at a "points" position. For example, a user may be provided with an option to accept the points and end the game or to forego the points for another opportunity to spin the spin mechanism 110-1, in which case processing may return to step 910 of Figure 9A.

[0095] If it is determined at step 955 that the spin did not stop at a "points" position, processing continues to step 970. In step 970, it is determined whether the spin action stopped at an "advance one level" position. An "advance one level" position may include any landing zone 330 associated with a virtual
25 passageway to an adjacent, higher level of game play (i.e., the next higher spin mechanism 110 in a hierarchy of spin mechanisms 110). In this case, an
30 "advance one level" position would provide a user an opportunity to advance game play from spin mechanism 110-1 to spin mechanism 110-2.

5 **[0096]** If it is determined at step 970 that the spin action has stopped at an "advance one level" position, processing continues at step 975. In step 975, any points associated with the "advance one level" position are added to the point total. Processing then moves to step 980, at which step a "get credit" subroutine
10 such as the one illustrated in Figure 8 is called. If sufficient credit is provided, processing continues from step 980 to step 1010 of Figure 10A, as indicated by "B1" in Figures 9B and 10A. Step 980 may be omitted from other implementations in which credit is not charged for a single level advancement associated with the "advance one level" position of step 970.

10 **[0097]** If it is determined at step 970 that the spin action has not stopped at an "advance one level" position, processing moves from step 970 to step 985. In step 985, it is determined whether the spin action has stopped at a shortcut (a type of virtual passageway) to the fourth spin mechanism 110-4. If it has, processing moves to step 990, at which step any points associated with the
15 shortcut position are added to the point total. Processing then moves from step 990 to step 1210 of Figure 12A, as indicated by "D1" in Figures 9B and 12A.

[0098] If it is determined at step 985 that the spin action has not stopped at the shortcut to spin mechanism 110-4, processing moves to step 995. By default based on the available stop positions of spin mechanism 110-1, it is
20 known that the spin action has stopped at a shortcut to the second spin mechanism 110-2. Any points associated with this stop position are added to the point total at step 995. Processing then moves from step 995 to step 1010 of Figure 10A, as indicated by "B1" in Figures 9B and 10A.

[0099] From the above description, it can be seen that in the exemplary
25 spin process for spin mechanism 110-1, several virtual passageways from spin mechanism 110-1 to other spin mechanisms 110-2 and 110-4 are available and can be utilized to cause game play to move from spin mechanism 110-1 to either spin mechanism 110-2 or 110-4. Of course, this example is not limiting. Other virtual passageways may be employed in other implementations.

30 **[0100]** Figures 10A-B illustrate an exemplary spin process for the second spin mechanism 110-2. The process may begin at step 1010. The beginning of the process at step 1010 is represented as "B1" in Figure 10A. The

performance of steps 1010-1050 as shown in Figure 10A is substantially similar to steps 910-950 of Figure 9A except that the steps are applied to spin mechanism 110-2 instead of spin mechanism 110-1.

[0101] In step 1050, if it is determined that the spin action has stopped, processing moves to step 1055 of Figure 10B, as indicated by "B2" in Figures 10A-B. In some implementations, if the brake is not already applied when the spin action comes to a stop, the brake may be applied to secure the stop position.

[0102] In step 1055, it is determined whether the spin action stopped at a "points" position as defined above. If it is determined that the spin action stopped at a "points" position, processing moves to step 1060. In step 1060, the points associated with the stop position are added to the point total. The game then ends at step 1065. Of course, this is illustrative. In other implementations, other options and/or actions may be performed when a spin of spin mechanisms 110-2 stops at a "points" position. For example, a user may be provided with an option to accept the points and end the game or to forego the points for another opportunity to spin the spin mechanism 110-2, in which case processing may return to step 1010 of Figure 10A.

[0103] If it is determined at step 1055 that the spin did not stop at a "points" position, processing continues to step 1070. In step 1070, it is determined whether the spin action stopped at an "advance one level" position as defined above. In this case, an "advance one level" position would provide a user an opportunity to advance game play from spin mechanism 110-2 to spin mechanism 110-3.

[0104] If it is determined at step 1070 that the spin action has stopped at an "advance one level" position, processing continues at step 1075. In step 1075, any points associated with the "advance one level" position are added to the point total. Processing then moves to step 1080, at which step a "get credit" subroutine such as the one illustrated in Figure 8 is called. If sufficient credit is provided, processing continues from step 1080 to step 1110 of Figure 11A, as indicated by "C1" in Figures 10B and 11A. Step 1080 may be omitted from other

implementations in which credit is not charged for a single level advancement associated with the "advance one level" position of step 1070.

[0105] If it is determined at step 1070 that the spin action has not stopped at an "advance one level" position, processing moves from step 1070 to step 1085. In step 1085, it is determined whether the spin action has stopped at a "back up one level" position. A "back up one level" position may include any landing zone 330 associated with a virtual passageway to an adjacent, lower level of game play (i.e., the next lower spin mechanism 110 in a hierarchy of spin mechanisms 110). In this case, a "back up one level" position would move game play from spin mechanism 110-2 to spin mechanism 110-1. This may be performed by moving processing from step 1085 of Figure 10B to step 910 of Figure 9A, as indicated by "A1" in Figures 9A and 10B.

[0106] In it is determined at step 1085 that the spin action has not stopped at a "back up one level" position, processing moves from step 1085 to step 1090. In step 1090, it is determined whether the spin action has stopped at a shortcut to the fourth spin mechanism 110-4. If it has, processing moves to step 1095, at which step any points associated with the shortcut position are added to the point total. Processing then moves from step 1095 to step 1210 of Figure 12A, as indicated by "D1" in Figures 10B and 12A.

[0107] If it is determined at step 1090 that the spin action has not stopped at the shortcut to spin mechanism 110-4, processing moves to step 1097. By default based on the available stop positions of spin mechanism 110-2, it is known at step 1097 that the spin action has stopped at a shortcut to the fifth spin mechanism 110-5. Any points associated with this stop position are added to the point total at step 1097. Processing then moves from step 1097 to step 1310 of Figure 13A, as indicated by "E1" in Figures 10B and 13A.

[0108] From the above description, it can be seen that in the exemplary spin process for spin mechanism 110-2 shown in Figures 10A-B, several virtual passageways to different spin mechanisms 110-1, 110-3, 110-4, and 110-5 are available and can be utilized to cause game play to move from spin mechanism 110-2 to spin mechanism 110-1, 110-3, 110-4, or 110-5. Of course, this example

is not limiting. Other virtual passageways may be employed in other implementations.

[0109] Figures 11A-B illustrate an exemplary spin process for the third spin mechanism 110-3. The process may begin at step 1110. The beginning of the process at step 1110 is represented as "C1" in Figure 10A. The performance of steps 1110-1150 as shown in Figure 11A may be substantially similar to steps 910-950 of Figure 9A as described above except that steps 1110-1150 are applied to spin mechanism 110-3 instead of spin mechanism 110-1.

[0110] Further, in step 1150, if it is determined that the spin action has stopped, processing moves to step 1155 of Figure 11B, as indicated by "C2" in Figures 11A-B. In some implementations, if the brake is not already applied when the spin action comes to a stop, the brake may be applied to secure the stop position.

[0111] In step 1155, it is determined whether the spin action stopped at a "points" position as defined above. If it is determined that the spin action stopped at a "points" position, processing moves to step 1160. In step 1160, the points associated with the stop position are added to the point total. The game then ends at step 1165. Of course, this is illustrative. In other implementations, other options and/or actions may be performed when a spin of spin mechanism 110-3 stops at a "points" position. For example, a user may be provided with an option to accept the points and end the game or to forego the points for another opportunity to spin the spin mechanism 110-3, in which case processing may return to step 1110 of Figure 11A.

[0112] If it is determined at step 1155 that the spin did not stop at a "points" position, processing continues to step 1170. In step 1170, it is determined whether the spin action stopped at an "advance one level" position as defined above. In this case, an "advance one level" position would provide a user an opportunity to advance game play from spin mechanism 110-3 to spin mechanism 110-4.

[0113] If it is determined at step 1170 that the spin action has stopped at an "advance one level" position, processing continues at step 1175. In step 1175, any points associated with the "advance one level" position are added to

the point total. Processing then moves to step 1180, at which step a "get credit" subroutine such as the one illustrated in Figure 8 is called. If sufficient credit is provided, processing continues from step 1180 to step 1210 of Figure 12A, as indicated by "D1" in Figures 11B and 12A. Step 1080 may be omitted from other implementations in which credit is not charged for a single level advancement associated with the "advance one level" position of step 1170.

[0114] If it is determined at step 1170 that the spin action has not stopped at an "advance one level" position, by default based on the available stop positions of spin mechanism 110-3, it is known that the spin action has stopped at a "back up one level" position. In this case, processing moves from step 1170 to step 1010 of Figure 10A, as indicated by "B1" in Figures 11B and 10A.

[0115] From the above description, it can be seen that in the exemplary spin process for spin mechanism 110-3 shown in Figures 11A-B, several virtual passageways to different spin mechanisms 110-2 and 110-4 are available and can be utilized to cause game play to move from spin mechanism 110-3 to spin mechanism 110-2 or 110-4. Of course, this example is not limiting. Other virtual passageways may be employed in other implementations.

[0116] Figures 12A-B illustrate an exemplary spin process for the fourth spin mechanism 110-4. The process may begin at step 1210. The beginning of the process at step 1210 is represented as "D1" in Figure 12A. The performance of steps 1210-1250 as shown in Figure 12A may be substantially similar to steps 910-950 of Figure 9A as described above except that steps 1210-1250 are applied to spin mechanism 110-4 instead of spin mechanism 110-1.

[0117] Further, in step 1250, if it is determined that the spin action has stopped, processing moves to step 1255 of Figure 12B, as indicated by "D2" in Figures 12A-B. In some implementations, if the brake is not already applied when the spin action comes to a stop, the brake may be applied to secure the stop position.

[0118] In step 1255, it is determined whether the spin action stopped at a "points" position as defined above. If it is determined that the spin action stopped at a "points" position, processing moves to step 1260. In step 1260, the

points associated with the stop position are added to the point total. The game then ends at step 1265. Of course, this is illustrative. In other implementations, other options and/or actions may be performed when a spin of spin mechanisms 110-4 stops at a "points" position. For example, a user may be provided with an option to accept the points and end the game or to forego the points for another opportunity to spin the spin mechanism 110-4, in which case processing may return to step 1210 of Figure 12A.

[0119] If it is determined at step 1255 that the spin did not stop at a "points" position, processing continues to step 1270. In step 1270, it is determined whether the spin action has stopped at a shortcut (a regressive type of virtual passageway) to the second spin mechanism 110-2. If it has, processing moves to step 1010 of Figure 10A, as indicated by "B1" in Figures 12B and 10A.

[0120] If it is determined at step 1270 that the spin action has not stopped at the shortcut to spin mechanism 110-2, processing moves to step 1275. In step 1275, it is determined whether the spin action has stopped at a "back up one level" position, as defined above. In this case, a "back up one level" position would move game play from spin mechanism 110-4 to spin mechanism 110-3. This may be performed by moving processing from step 1275 of Figure 12B to step 1110 of Figure 11A, as indicated by "C1" in Figures 11A and 12B.

[0121] In it is determined at step 1275 that the spin action has not stopped at a "back up one level" position, processing moves from step 1275 to step 1280. In step 1280, it is determined whether the spin action stopped at an "advance one level" position, as defined above. In this case, an "advance one level" position would provide a user an opportunity to advance game play from spin mechanism 110-4 to spin mechanism 110-5.

[0122] If it is determined at step 1280 that the spin action has stopped at an "advance one level" position, processing continues at step 1285. In step 1285, any points associated with the "advance one level" position are added to the point total. Processing then moves to step 1290, at which step a "get credit" subroutine such as the one illustrated in Figure 8 is called. If sufficient credit is received, processing continues from step 1290 to step 1310 of Figure 13A, as indicated by "E1" in Figures 12B and 13A. Step 1290 may be omitted from other

implementations in which credit is not charged for a single level advancement associated with the "advance one level" position of step 1290.

[0123] If it is determined at step 1280 that the spin action has not stopped at an "advance one level" position, by default based on the available stop positions of spin mechanism 110-4, it is known that the spin action has stopped at a regressive shortcut (e.g., a "booby trap") to the first spin mechanism 110-1. Processing then moves from step 1280 to step 910 of Figure 9A, as indicated by "A1" in Figures 9A and 12B.

[0124] From the above description, it can be seen that in the exemplary spin process for spin mechanism 110-4 shown in Figures 12A-B, several virtual passageways to different spin mechanisms 110-1, 110-2, 110-3, and 110-5 are available and can be utilized to cause game play to move from spin mechanism 110-4 to spin mechanism 110-1, 110-2, 110-3, or 110-5. Of course, this example is not limiting. Other virtual passageways may be employed in other implementations.

[0125] Figures 13A-B illustrate an exemplary spin process for the fifth spin mechanism 110-5. The process may begin at step 1310. The beginning of the process at step 1310 is represented as "E1" in Figure 13A. The performance of steps 1310-1350 as shown in Figure 13A may be substantially similar to steps 910-950 of Figure 9A as described above except that steps 1310-1350 are applied to spin mechanism 110-5 instead of spin mechanism 110-1.

[0126] Further, in step 1350, if it is determined that the spin action has stopped, processing moves to step 1355 of Figure 13B, as indicated by "E2" in Figures 13A-B. In some implementations, if the brake is not already applied when the spin action comes to a stop, the brake may be applied to secure the stop position.

[0127] In step 1355, it is determined whether the spin action stopped at a "points" position as defined above. If it is determined that the spin action stopped at a "points" position, processing moves to step 1360. In step 1360, the points associated with the stop position are added to the point total. The game then ends at step 1365. Of course, this is illustrative. In other implementations, other options and/or actions may be performed when a spin of spin mechanisms

110-5 stops at a "points" position. For example, a user may be provided with an option to accept the points and end the game or to forego the points for another opportunity to spin the spin mechanism 110-5, in which case processing may return to step 1310 of Figure 13A.

5 **[0128]** If it is determined at step 1355 that the spin did not stop at a "points" position, processing continues to step 1370. In step 1370, it is determined whether the spin action has stopped at a "bonus" position. The fifth spin mechanism 110-5 may include one or more "bonus" positions, which may provide a special level of reward, such as a top prize or high number of points.

10 **[0129]** If it is determined that the stop action has stopped at a "bonus" position, processing moves to step 1375. In step 1375, the "bonus" reward(s) associated with the "bonus" position are awarded. For example, "bonus" points may be added to the point total. The game then ends at step 1365.

15 **[0130]** If it is determined at step 1370 that the spin action has not stopped at a "bonus" position, processing moves from step 1370 to step 1380. In step 1380, it is determined whether the spin action has stopped at a "back up one level" position, as defined above. In this case, a "back up one level" position would move game play from spin mechanism 110-5 to spin mechanism 110-4. This may be performed by moving processing from step 1380 of Figure 13B to
20 step 1210 of Figure 12A, as indicated by "D1" in Figures 12A and 13B.

[0131] If it is determined at step 1380 that the spin action has not stopped at a "back up one level" position, processing moves from step 1380 to step 1385. In step 1385, it is determined whether the spin action has stopped at a regressive shortcut to the second spin mechanism 110-2. If it has, processing
25 moves to step 1010 of Figure 10A, as indicated by "B1" in Figures 13B and 10A.

[0132] If it is determined at step 1385 that the spin action has not stopped at the shortcut to spin mechanism 110-2, by default based on the available stop positions of spin mechanism 110-5, it is known that the spin action has stopped at a regressive shortcut to the first spin mechanism 110-1.
30 Processing then moves from step 1385 to step 910 of Figure 9A, as indicated by "A1" in Figures 9A and 13B.

[0133] From the above description, it can be seen that in the exemplary spin process for spin mechanism 110-5 shown in Figures 13A-B, several virtual passageways to different spin mechanisms 110-1, 110-2, and 110-4 are available and can be utilized to cause game play to move from spin mechanism 110-5 to spin mechanism 110-1, 110-2, or 110-4. Of course, this example is not limiting. Other virtual passageways may be employed in other implementations.

[0134] Figures 8-13B and the above corresponding description are illustrative of one of many possible configurations of multiple spin mechanisms 110 and associated rewards, including one of many possible configurations of virtual passageways between the spin mechanisms 110. Other implementations may include different configurations.

[0135] By providing multiple spin mechanisms 110 and virtual passageways between them, a game apparatus such as game apparatus 100 can provide a variety of possibilities and outcomes. Such entertainment value can attract repeat players and facilitate extended game play, which can lead to significant returns on investment.

IV. ALTERNATIVE EMBODIMENTS

[0136] The preceding description has been presented only to illustrate and describe exemplary implementations with reference to the accompanying drawings. It will, however, be evident that various modifications and changes may be made thereto, and additional implementations may be implemented, without departing from the scope of the invention as set forth in the claims that follow. The above description and accompanying drawings are accordingly to be regarded in an illustrative rather than a restrictive sense.

CLAIMS

WHAT IS CLAIMED IS:

- 5 1. A game apparatus (100), comprising:
 a plurality of spin mechanisms (110) including at least a first spin
 mechanism (110-1) and a second spin mechanism (110-2); and
 a control unit (224) communicatively connected to said plurality of spin
 mechanisms (110), said control unit (224) being configured to provide a virtual
10 passageway enabling game play to move between said first spin mechanism
 (110-1) and said second spin mechanism (110-2).
2. The game apparatus (100) of claim 1, wherein said first spin
 mechanism (110-1) includes a plurality of landing zones (330), one of said
15 landing zones (330) being associated with said virtual passageway.
3. The game apparatus (100) of claim 2, wherein said first spin
 mechanism (110-1) is configured to perform a spin action and to stop the spin
 action at any one of said landing zones (330).
- 20 4. The game apparatus (100) of claim 3, wherein said control unit
 (224) is configured to
 determine when the spin action has stopped on said one of said landing
 zones (330) associated with said virtual passageway, and
25 move game play from said first spin mechanism (110-1) to said second
 mechanism (110-2) in response to the determination.
5. The game apparatus (100) of claim 4, wherein said second spin
 mechanism (110-2) includes a plurality of other landing zones (330), one of said
30 other landing zones (330) being associated with another virtual passageway.

6. The game apparatus (100) of claim 5, wherein said second spin mechanism (110-2) is configured to perform a spin action and to stop the spin action at any one of said other landing zones (330).

5 7. The game apparatus (100) of claim 6, wherein said control unit (224) is configured to
determine when the spin action of said second spin mechanism (110-2) has stopped on said one of said other landing zones (330) associated with said another virtual passageway, and
10 move game play from said second spin mechanism (110-2) to said first mechanism (110-1) in response to the determination.

8. The game apparatus (100) of claim 1, further comprising at least one control (120) communicatively connected to said control unit (224), said at
15 least one control (120) enabling a user of said game apparatus (100) to initiate and stop a spin action of an active one of said spin mechanisms (110).

9. The game apparatus (100) of claim 8, wherein said at least one control (120) includes a slow stop spin control (260) and a quick stop spin control
20 (265).

10. The game apparatus (100) of claim 9, wherein said control unit (224) is configured to activate said quick stop spin control (265) when the spin action of said active spin mechanism (110) reaches a predetermined speed.
25

11. The game apparatus (100) of claim 10, wherein said control unit (224) is configured to terminate power to said active spin mechanism (110) in response to the user actuating the slow stop spin control (260).

30 12. The game apparatus (100) of claim 10, wherein said control unit (224) is configured to terminate power and apply a brake (530) to said active spin

mechanism (110) in response to the user actuating the quick stop spin control (265).

13. The game apparatus (100) of claim 8, further comprising a cabinet (130) housing said plurality of spin mechanisms (110), said control unit (224), and said at least one control (120).

14. The game apparatus (100) of claim 13, wherein said cabinet (130) includes a base unit (140) and an expansion (150) unit removably attached to said base unit (140), said expansion unit (150) housing one of said spin mechanisms (110) and said base unit (140) housing the remaining said spin mechanisms (110).

15. The game apparatus (100) of claim 1, wherein each of said spin mechanisms (110) includes a plurality of landing zones (330) associated with a set of rewards.

16. The game apparatus (100) of claim 1, wherein each of said spin mechanisms (110) is associated with a level of a hierarchy, each said level being associated with a different set of available rewards.

17. A game apparatus (100), comprising:
a cabinet (130);
a plurality of spin mechanisms (110) housed in said cabinet (130), each of said spin mechanisms (110) including a plurality of landing zones (330) associated with a set of rewards, each of said spin mechanisms (110) being configured to perform a spin action and to stop the spin action at any one of said landing zones (330); and
a control unit (224) housed in said cabinet (130) and communicatively connected to said plurality of spin mechanisms (110), said control unit (224) being configured to communicate with and control each of said spin mechanisms (110), including

activating game play at one of said spin mechanisms (110),
initiating the spin action of said spin mechanism (110),
initiating the stop of the spin action of said spin mechanism (110),
identifying one of said landing zones (330) of said spin mechanism
5 (110) at which the spin action stopped, and
initiating at least one action associated with said landing zone
(330).

18. The game apparatus (100) of claim 17, wherein said at least one
10 action includes moving game play from said spin mechanism (110) to another of
said spin mechanisms (110) when said landing zone (330) is associated with a
virtual passageway between said spin mechanism (110) and said another spin
mechanism (110).

15 19. A method, comprising:
activating game play at a spin mechanism (110) included in a plurality of
spin mechanisms (110);
initiating a spin action of the spin mechanism (110);
stopping the spin action;
20 determining a stop position of the spin action; and
moving game play to another spin mechanism (110) included in said
plurality of spin mechanisms (110) when the stop position of the spin action is
associated with a virtual passageway between the spin mechanism (110) and the
other spin mechanism (110).

25 20. The method of claim 19, further comprising providing a reward
when the stop position of the spin action is associated with the reward.

1/18

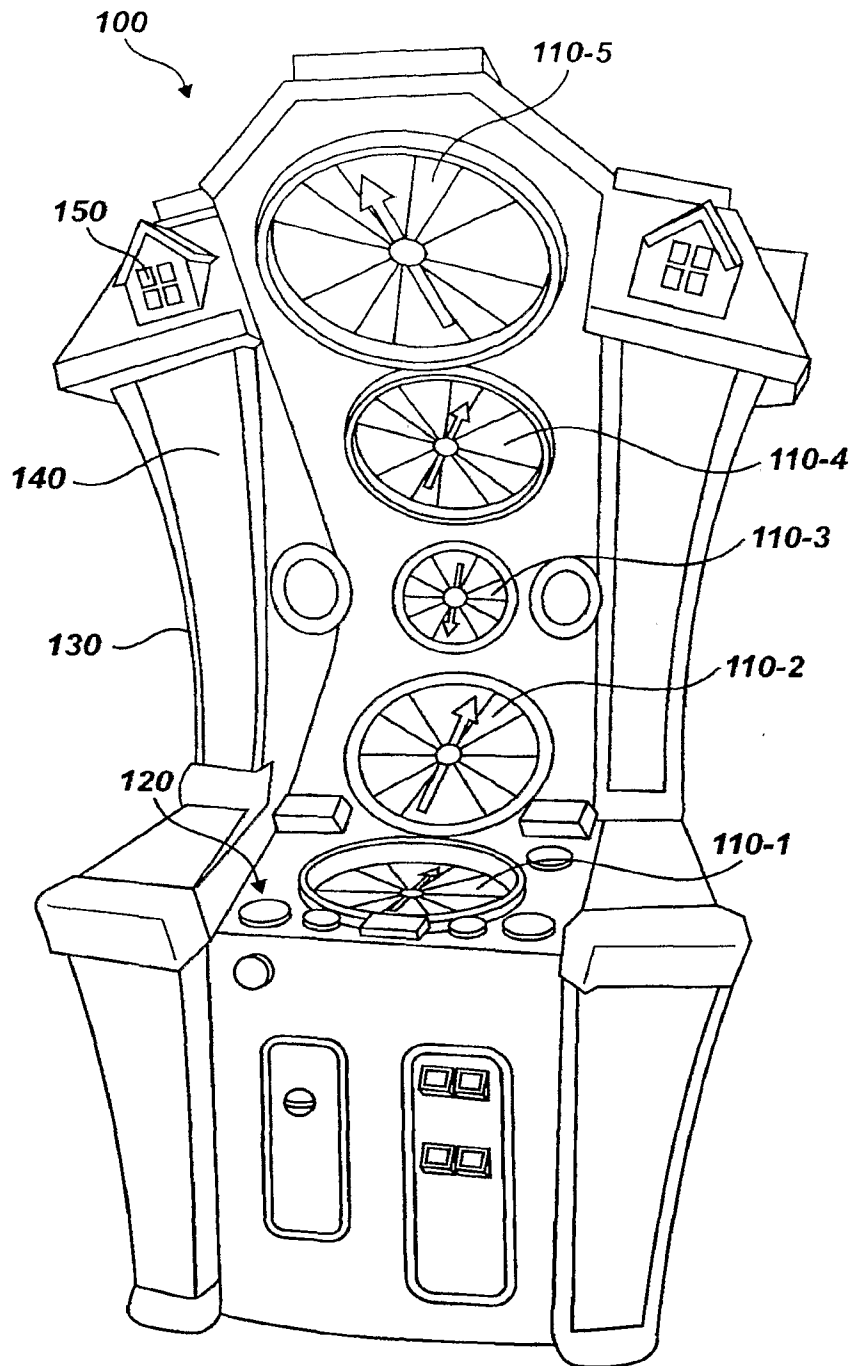

Fig. 1

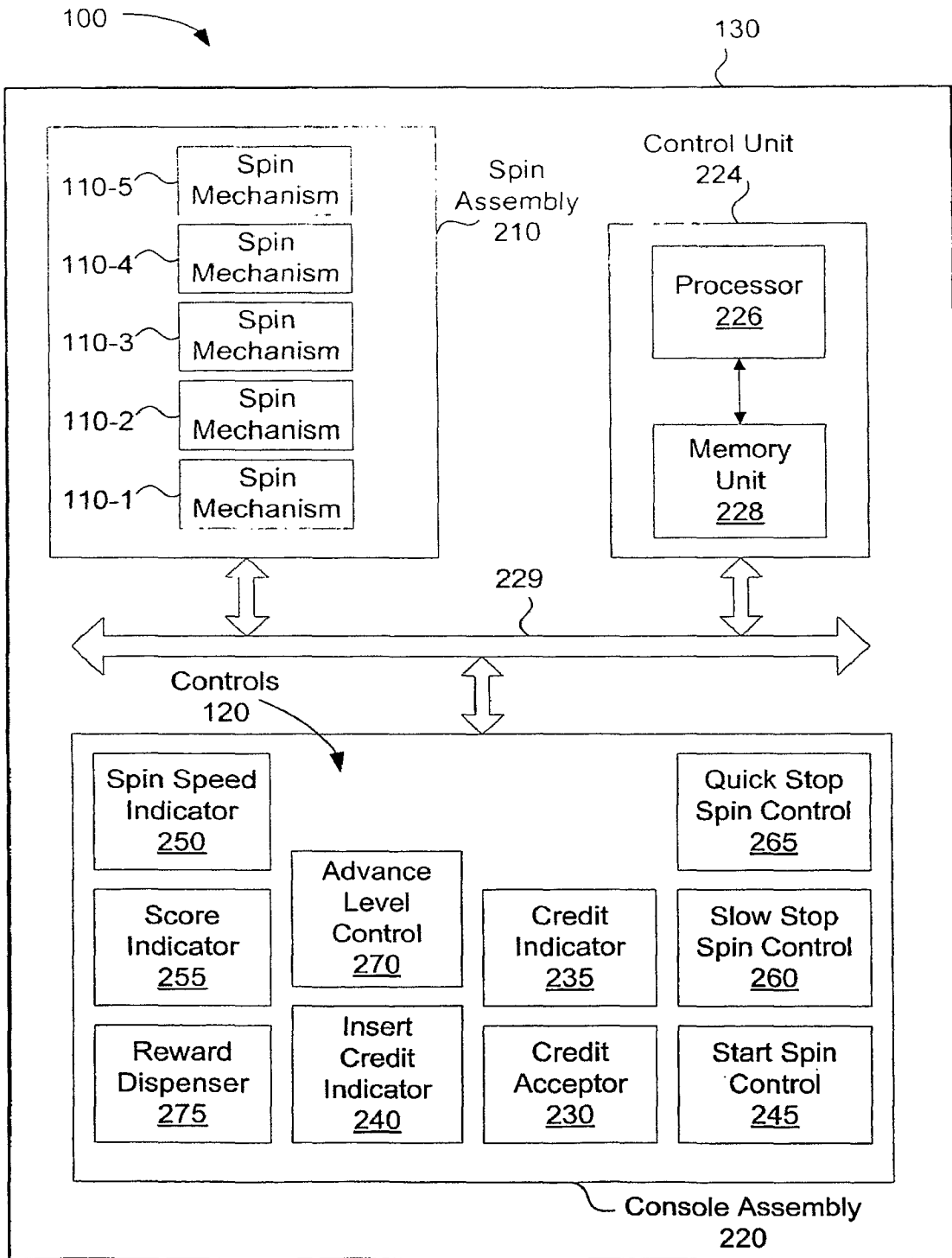

Fig. 2

3/18

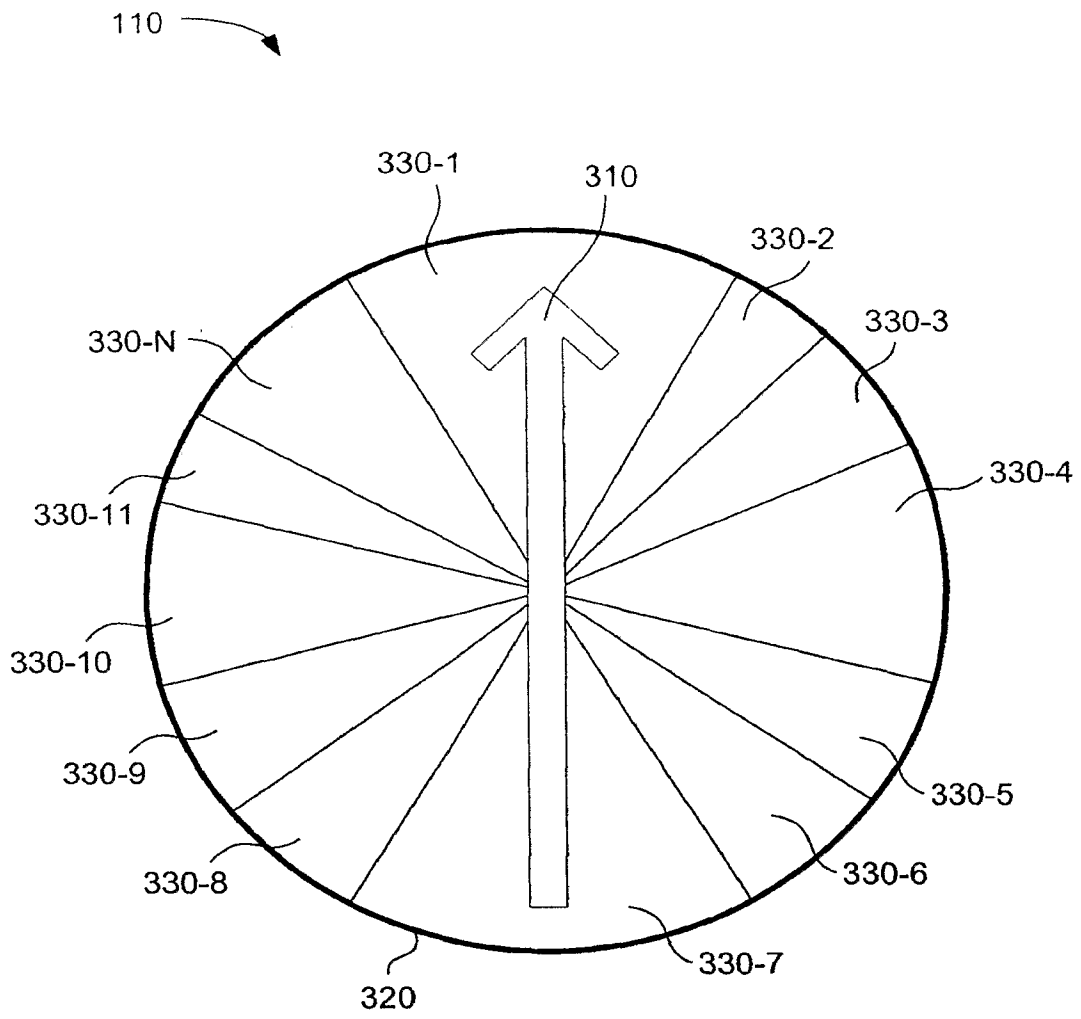

Fig. 3

4/18

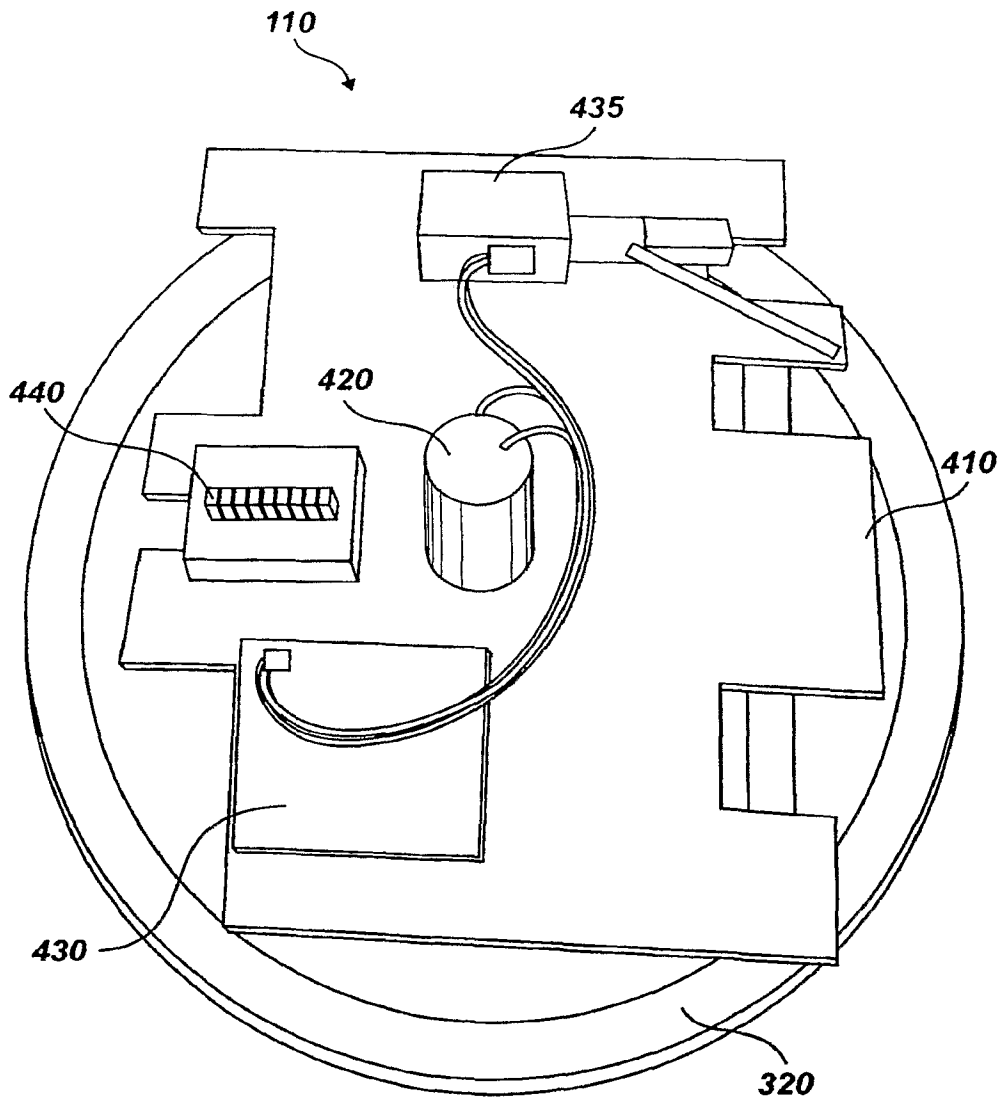

Fig. 4

5/18

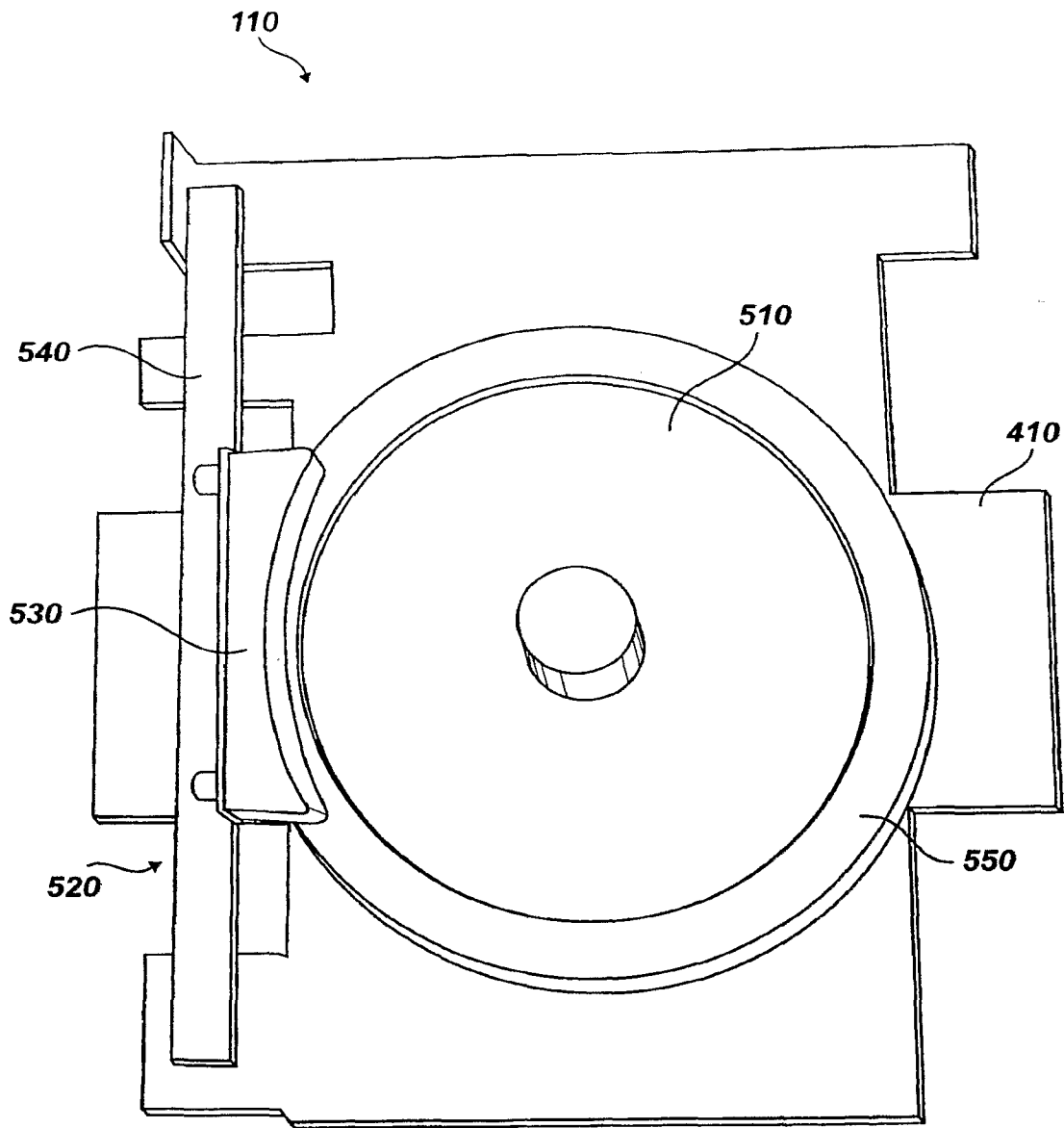

Fig. 5

6/18

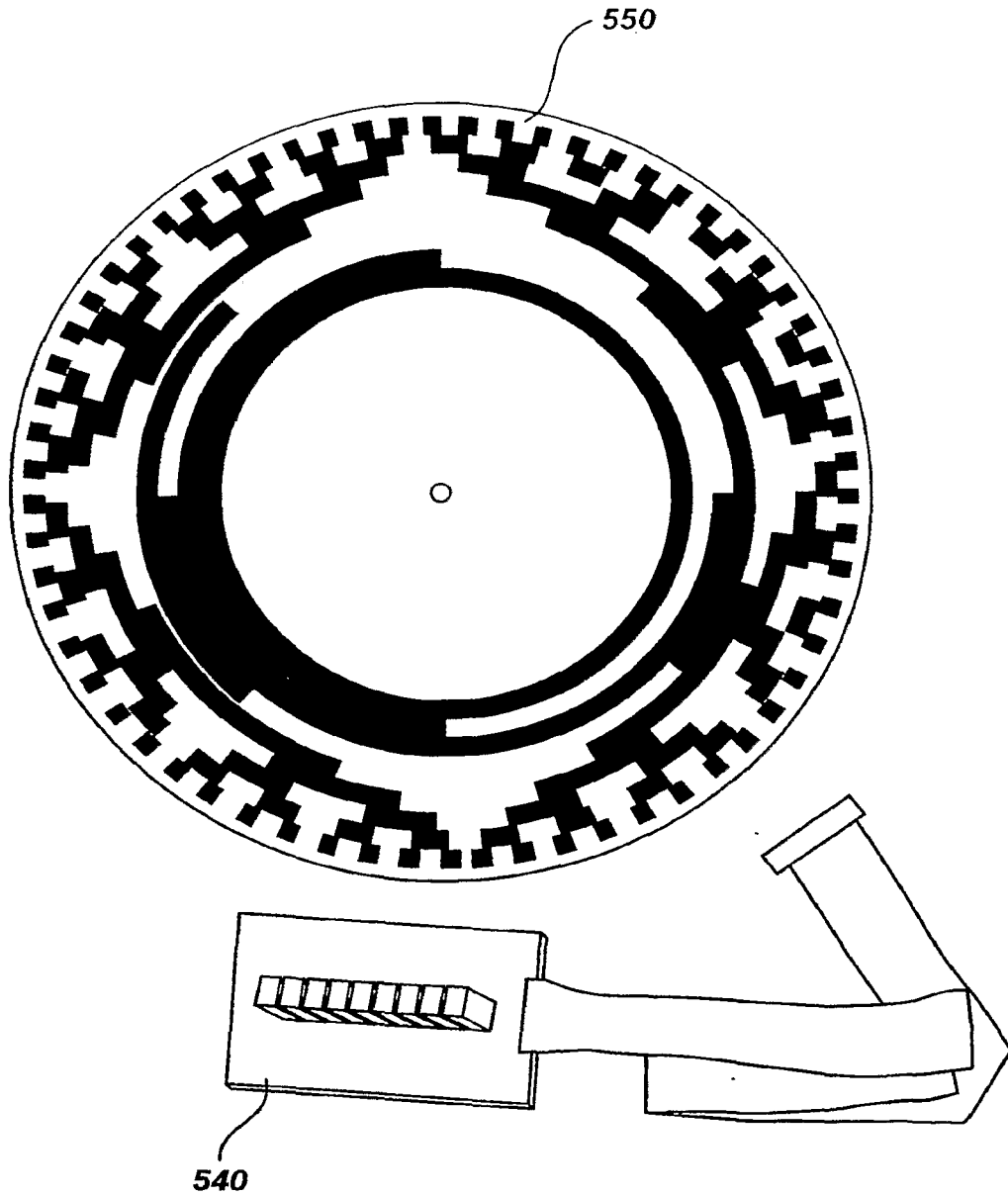

Fig. 6

7/18

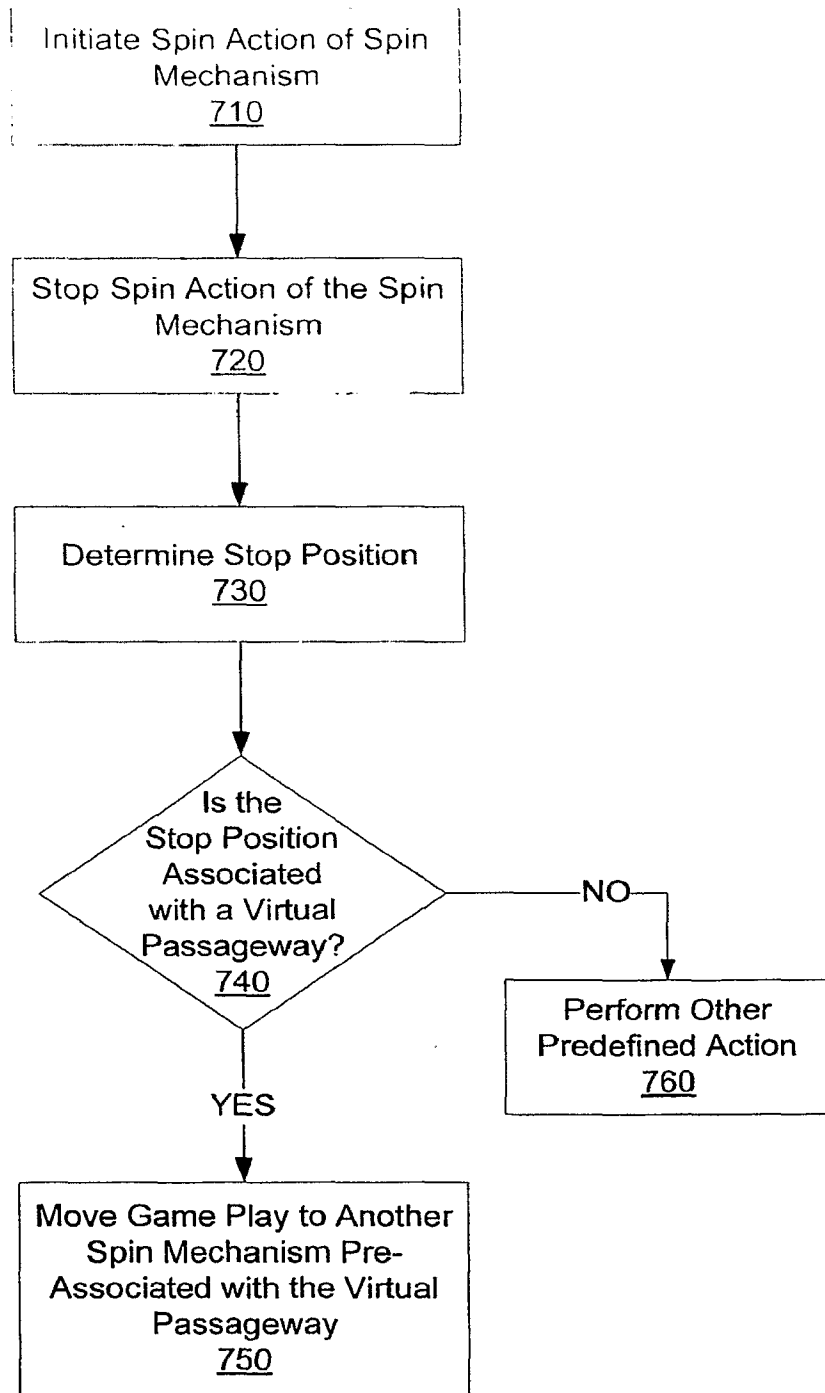

Fig. 7

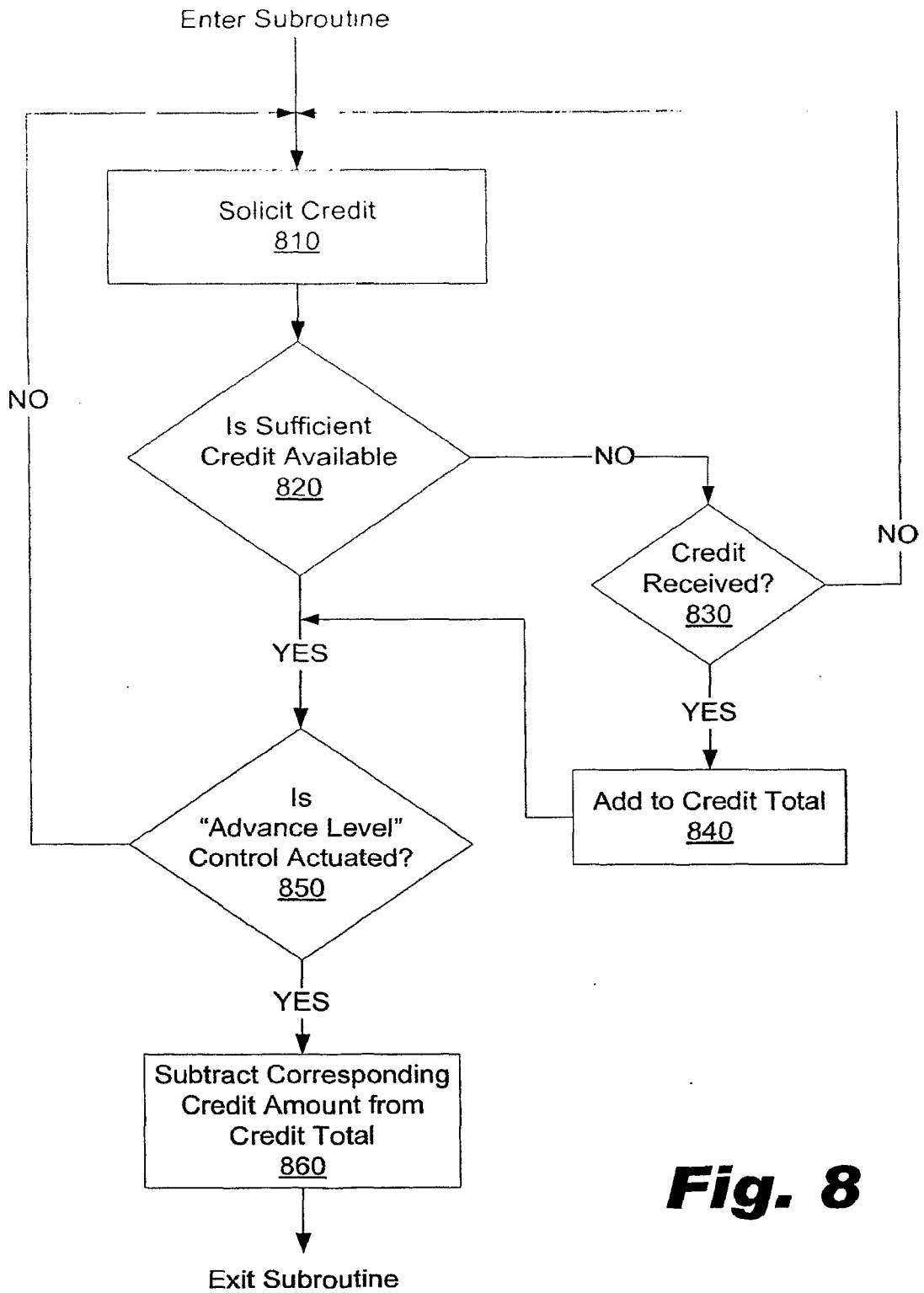

Fig. 8

9/18

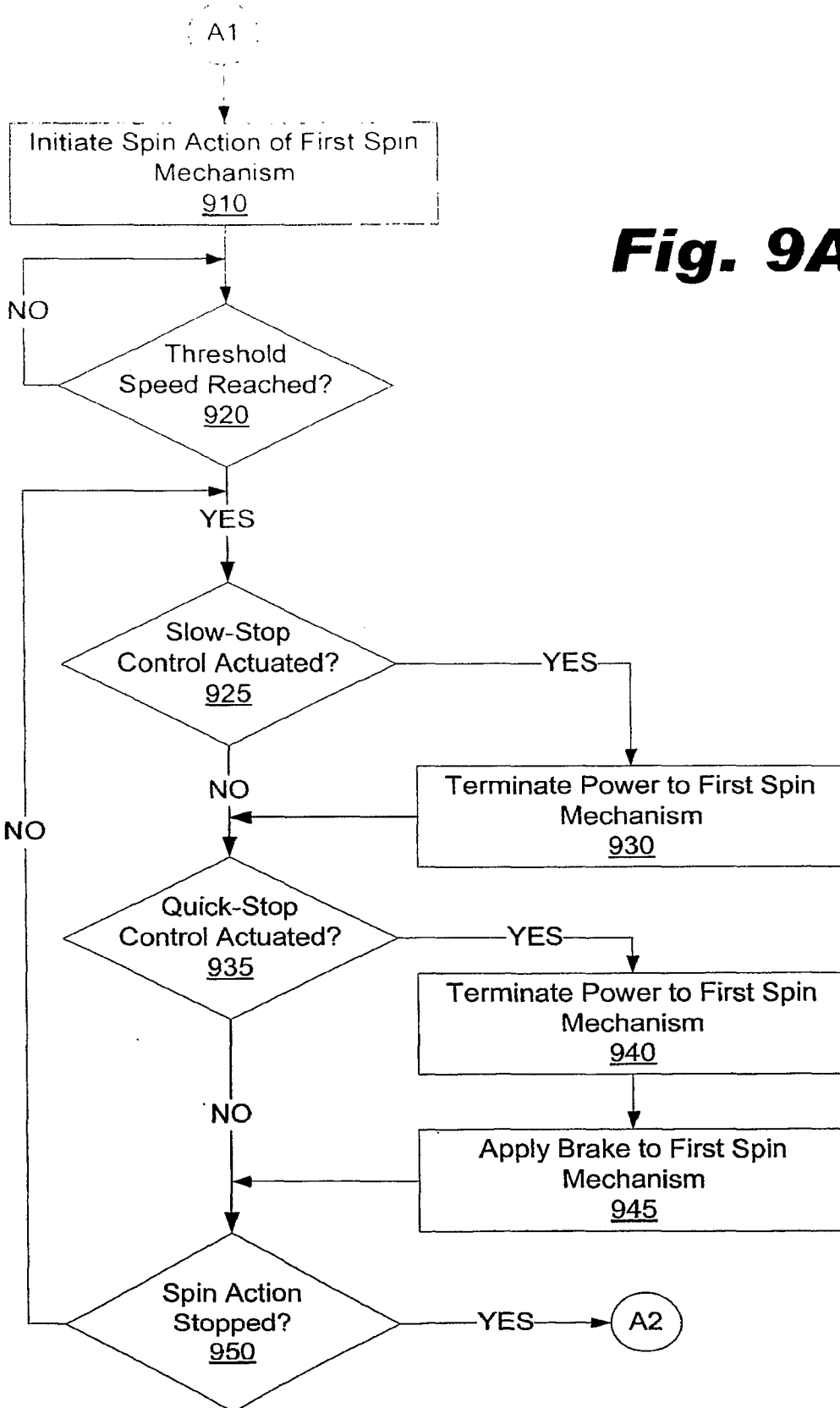

Fig. 9A

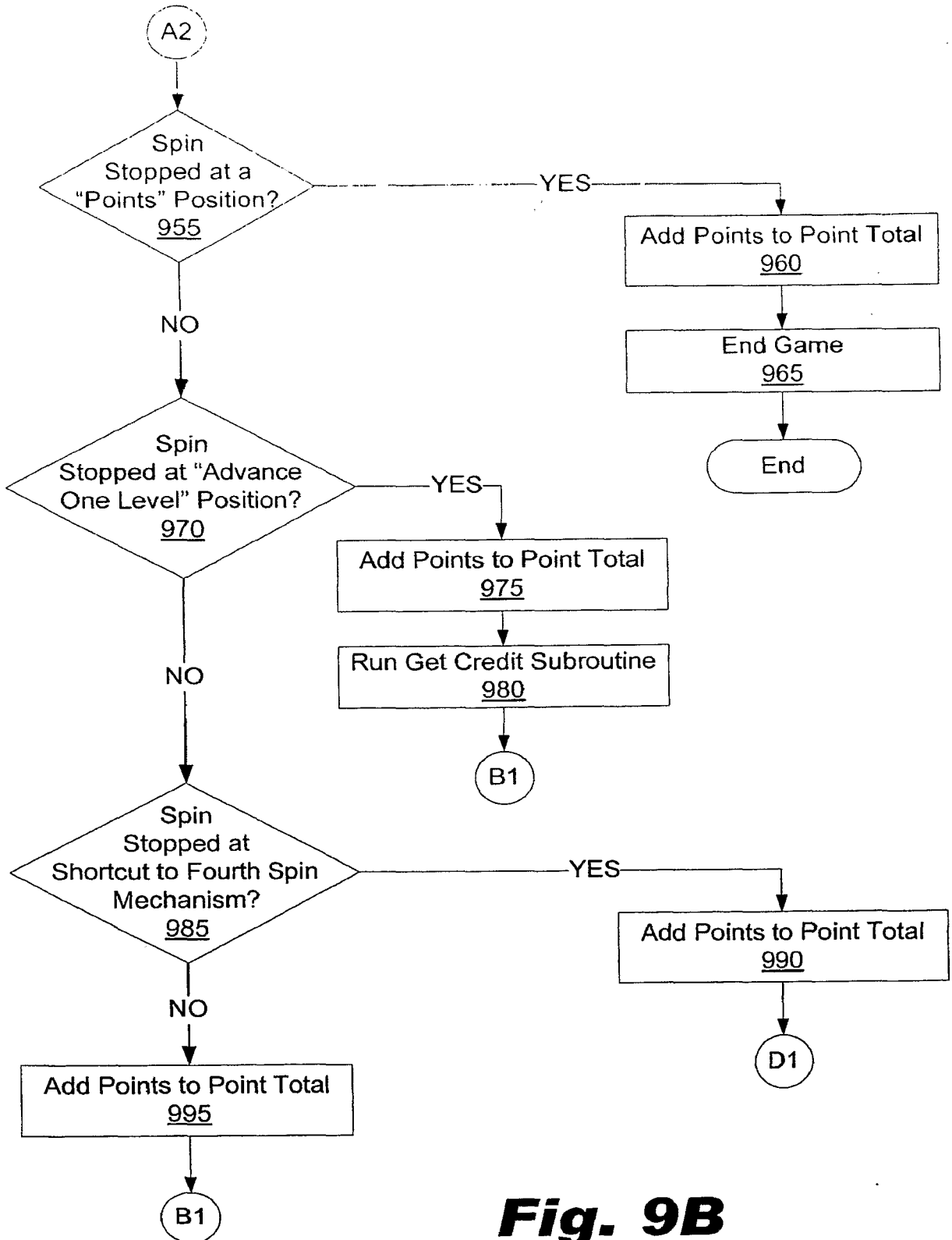

Fig. 9B

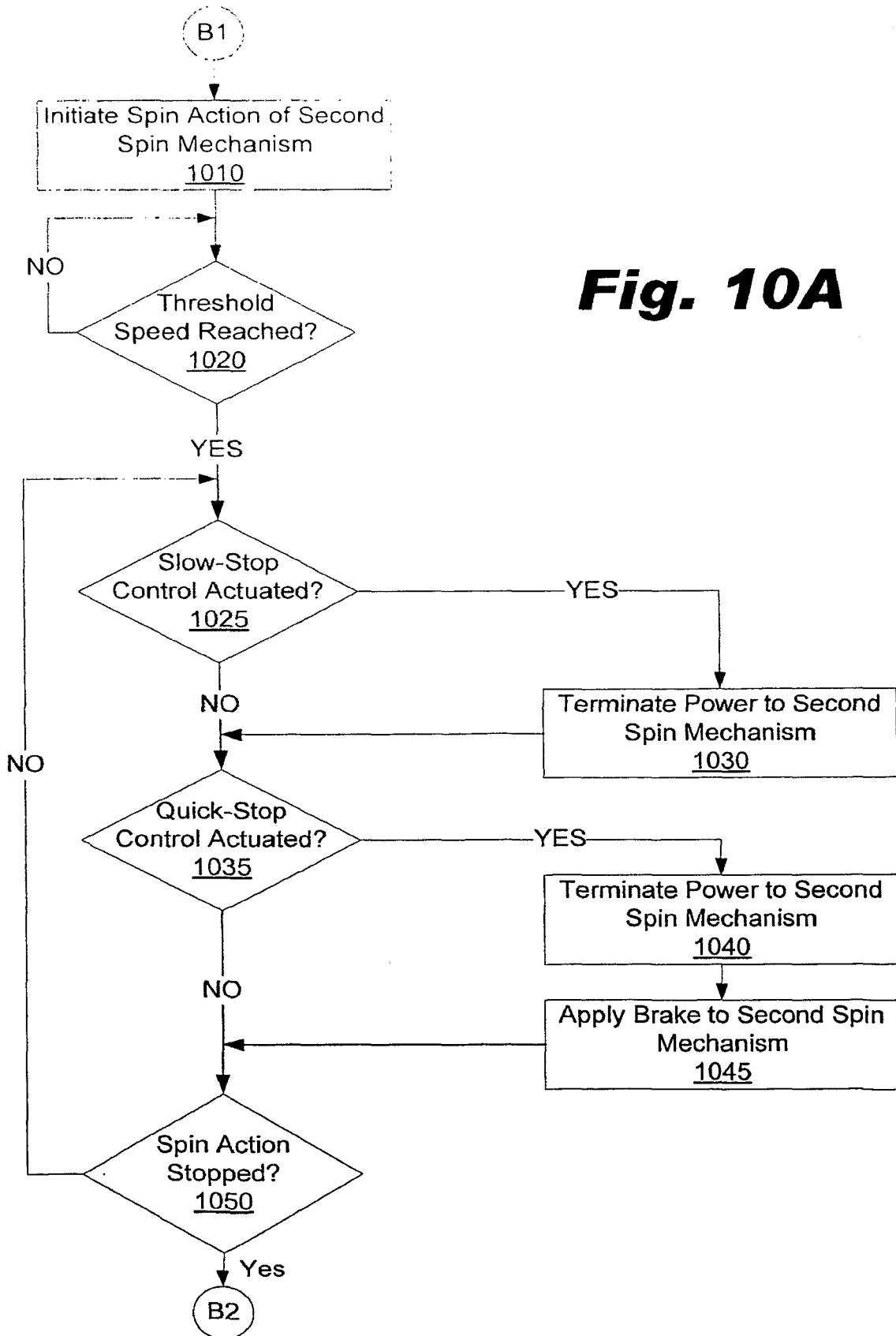

Fig. 10A

12/18

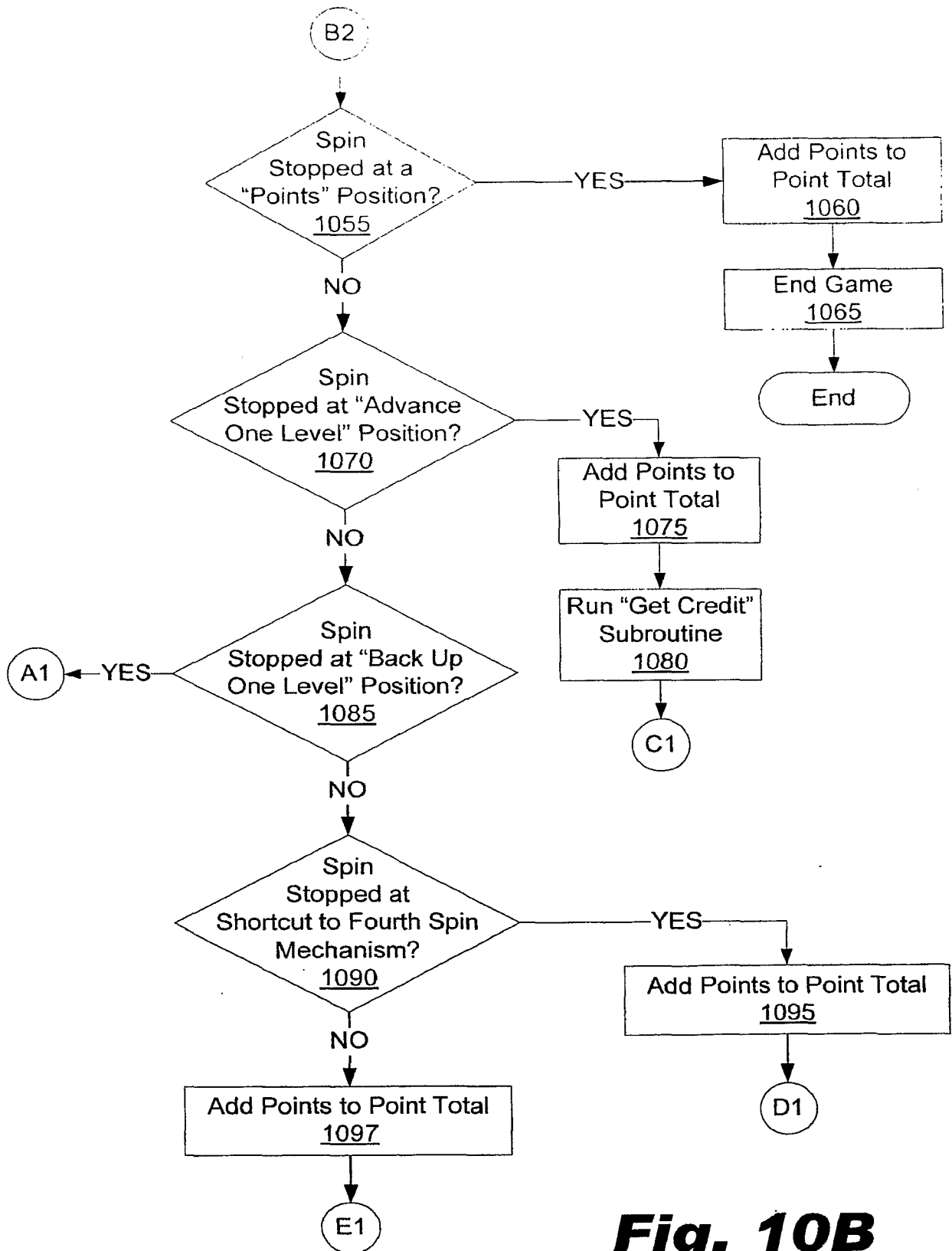
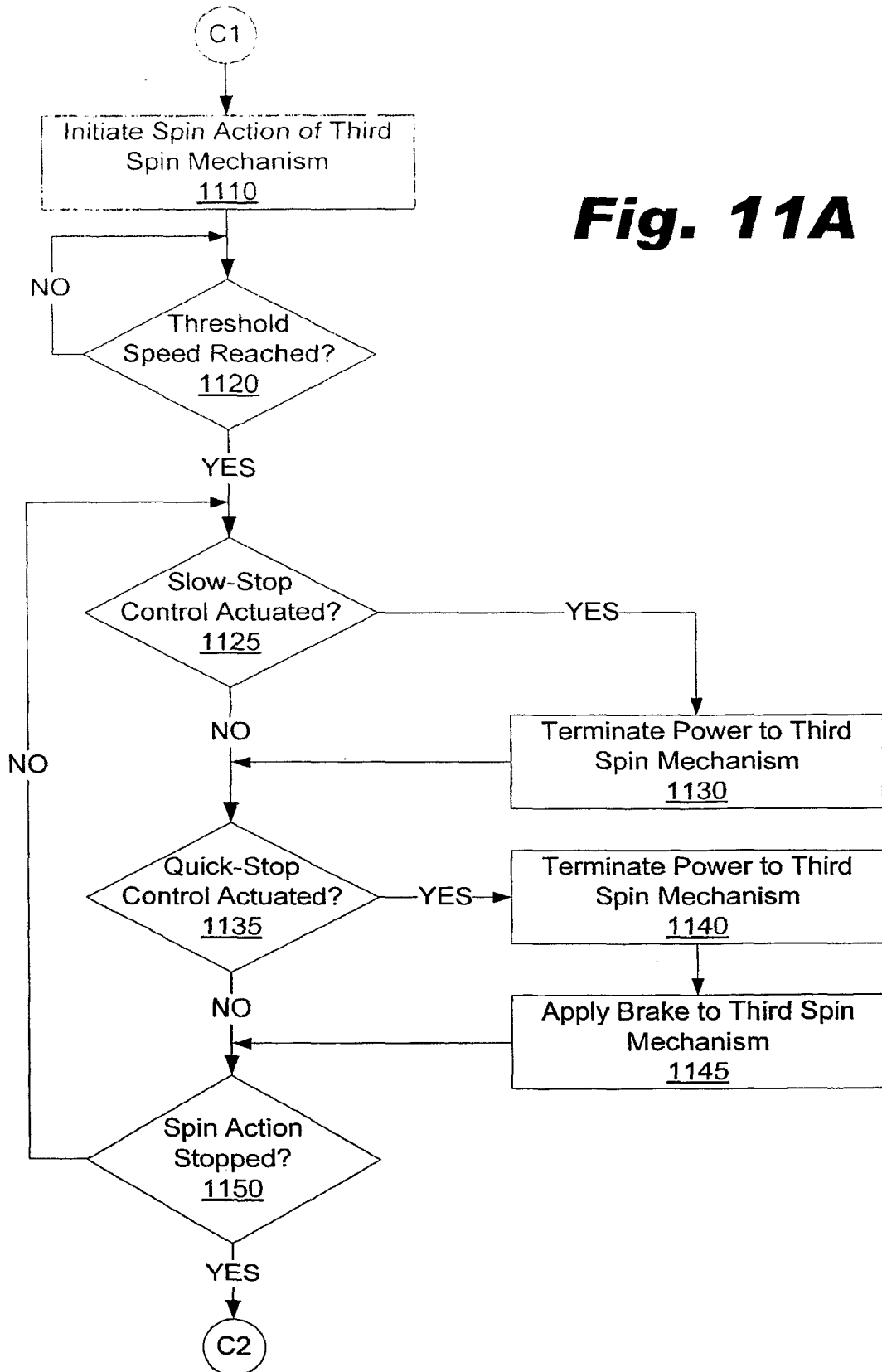

Fig. 10B

Fig. 11A



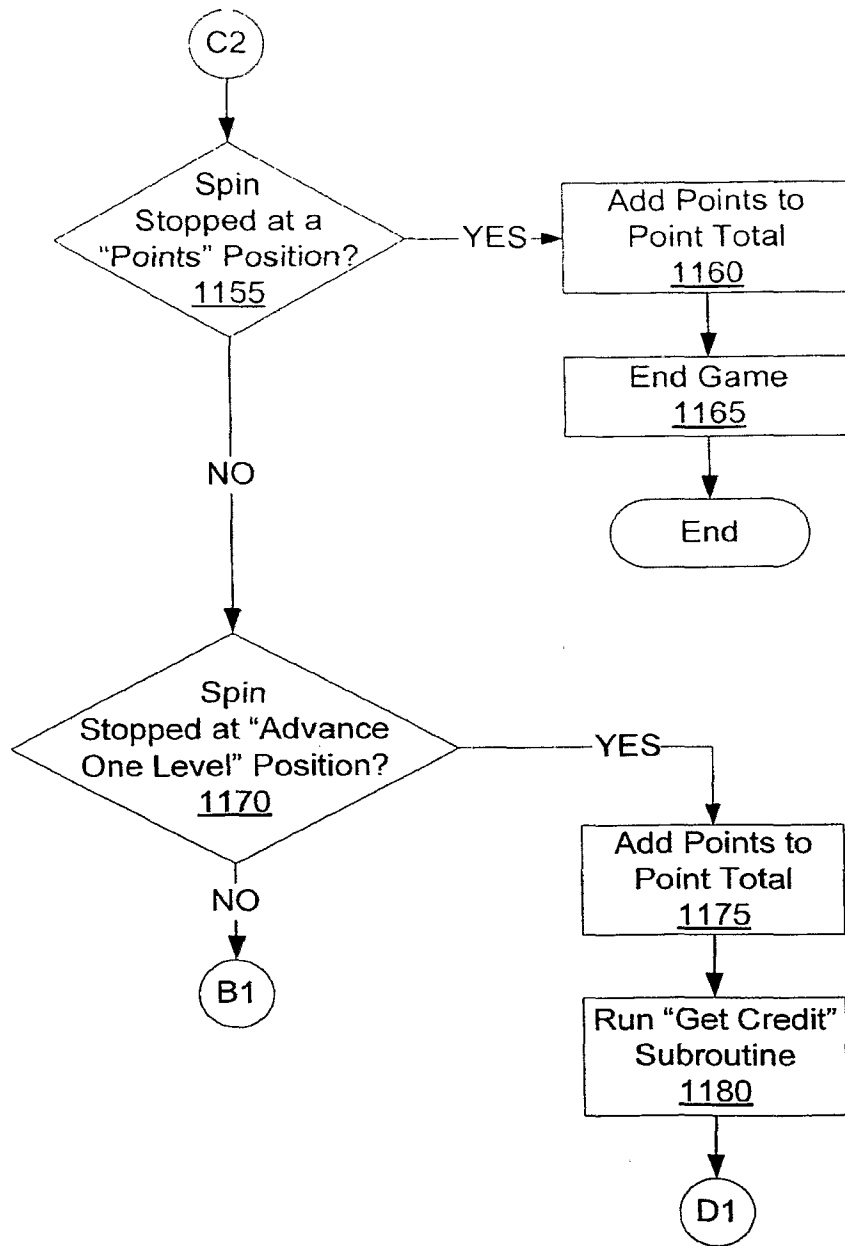
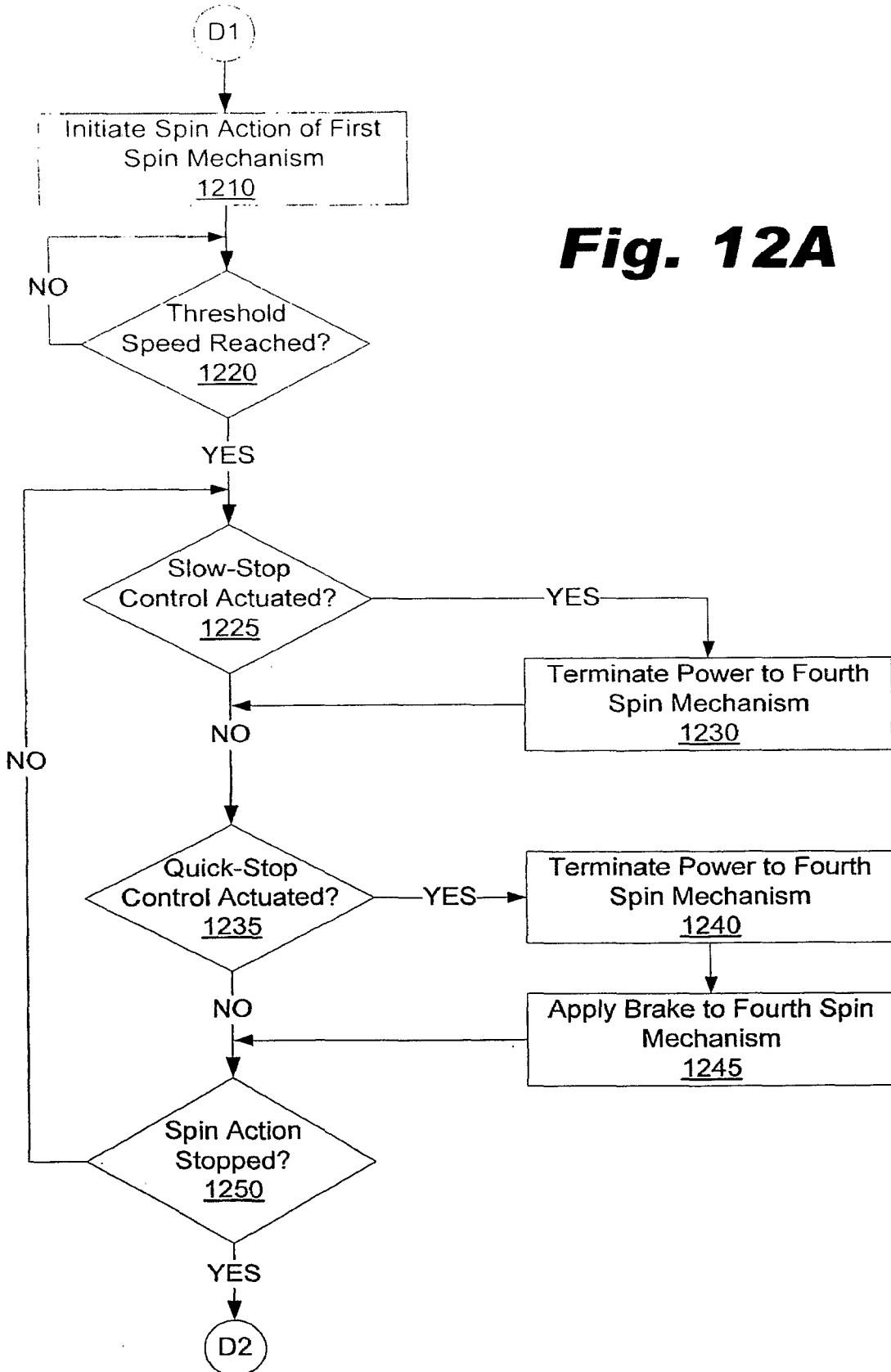

Fig. 11B

Fig. 12A



16/18

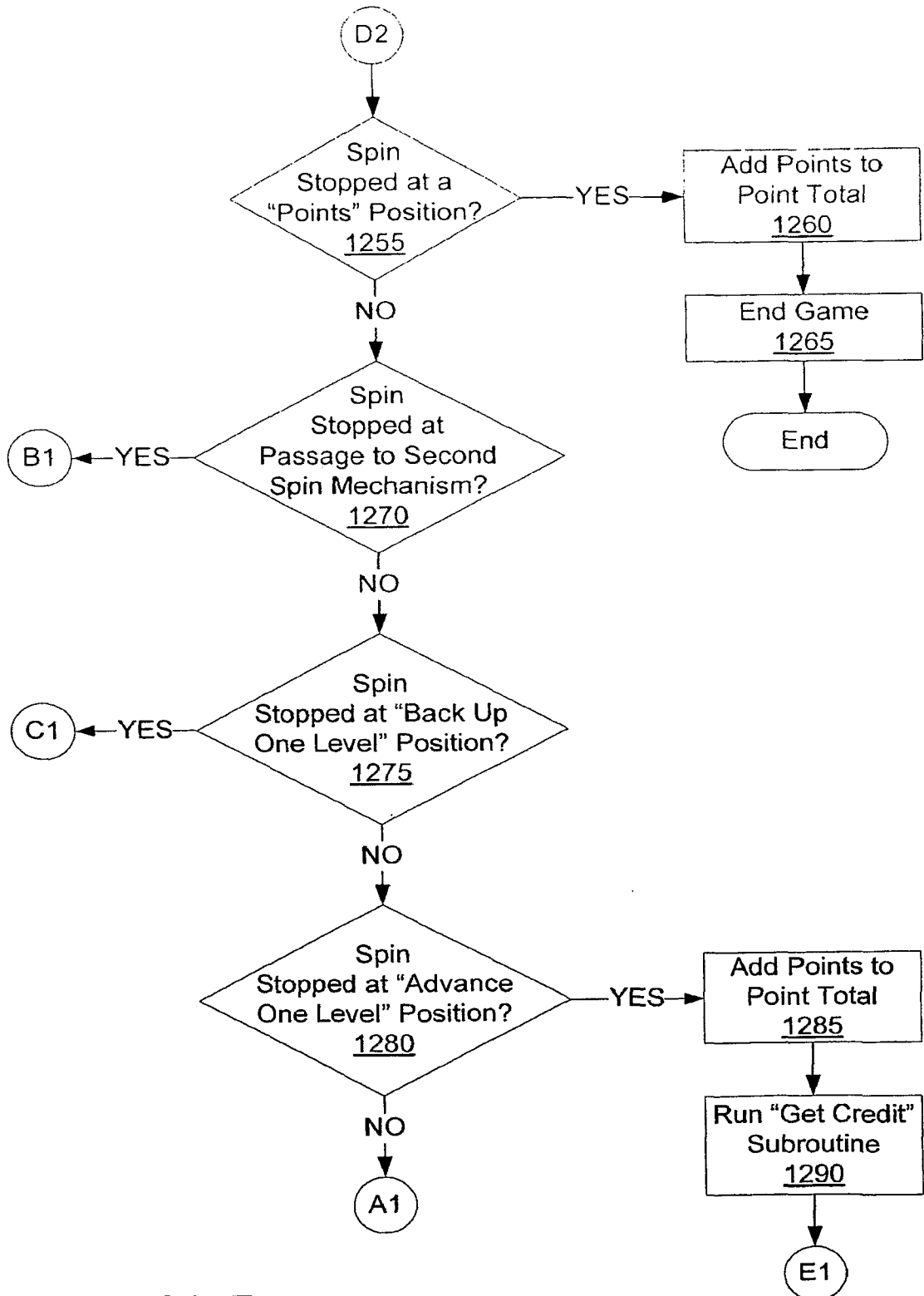
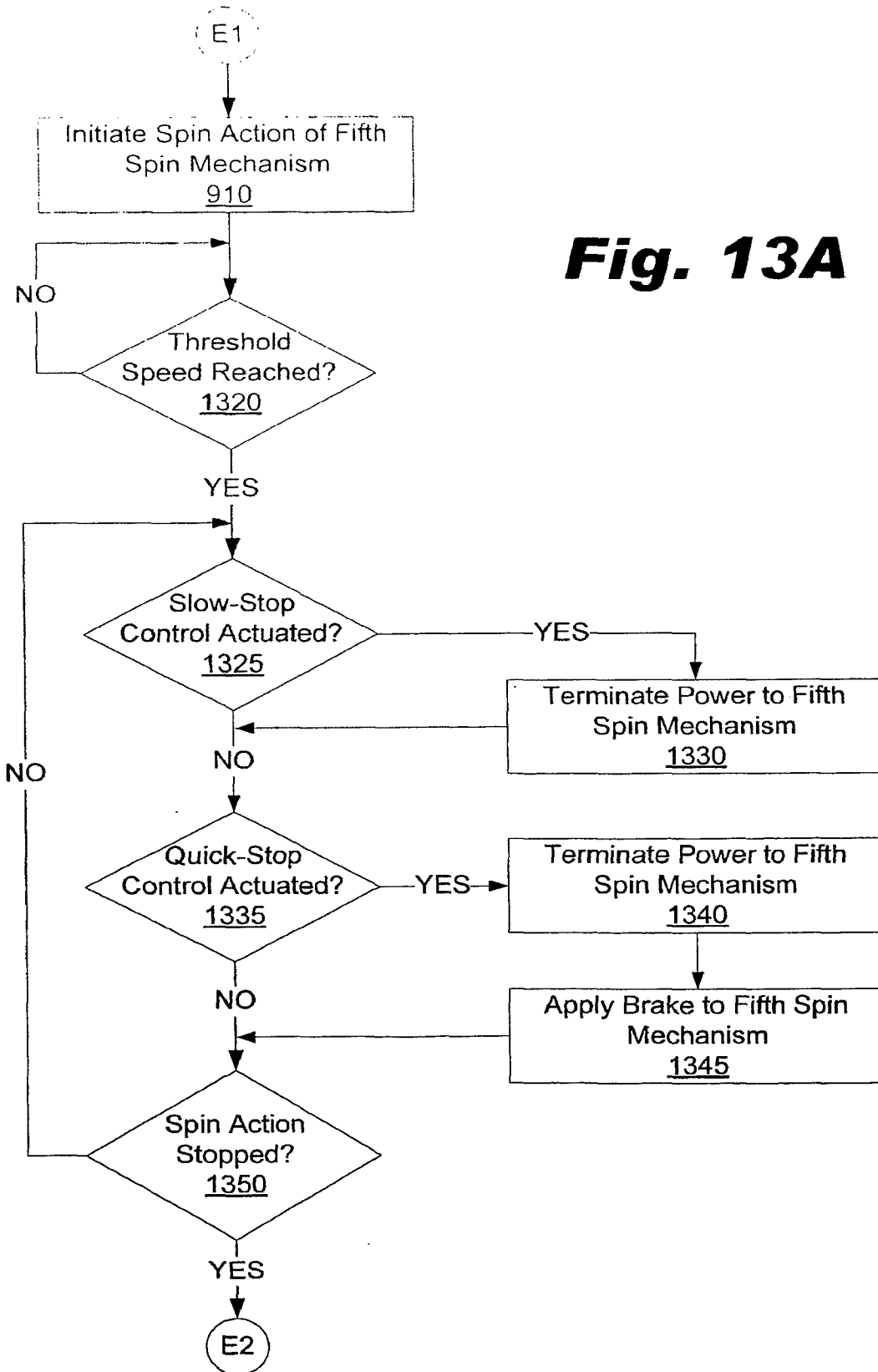

Fig. 12B

Fig. 13A



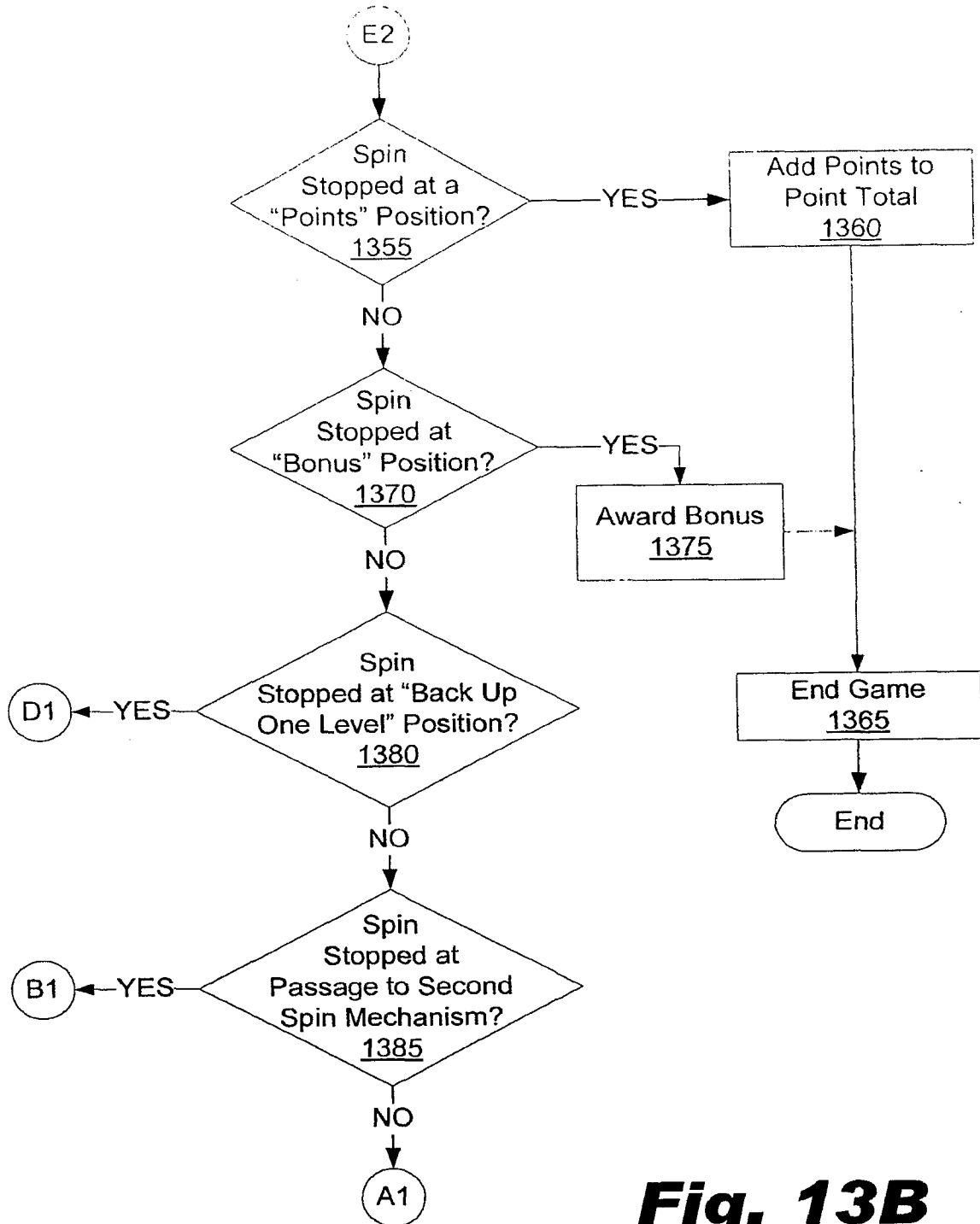

Fig. 13B