

[54] MECHANICAL PENCIL

[75] Inventor: Yoshihide Mitsuya, Osaka, Japan

[73] Assignee: Yoshihide Mitsuya, Osaka, Japan

[22] Filed: Feb. 28, 1974

[21] Appl. No.: 447,036

[52] U.S. Cl. 401/67

[51] Int. Cl.² B43K 21/16

[58] Field of Search 401/65-67,
401/57, 58, 92-94, 109

[56] References Cited

UNITED STATES PATENTS

3,724,960	4/1973	Hashimoto.....	401/67
3,765,781	10/1973	Hashimoto.....	401/67

Primary Examiner—Lawrence Charles

Attorney, Agent, or Firm—Wenderoth, Lind & Ponack

[57] ABSTRACT

A mechanical pencil has a lead container movably in-

corporated therein. The lower terminal portion of the pencil proper contains a lead protecting tube through which the lead extends in light frictional contact. The lead container is provided at the lower end thereof with a chuck which functions for clutching and releasing the lead alternately during operation thereof. Within the lower terminal portion is also a movable cylinder to which the chuck becomes attached when the chuck in a loosened state is moved downwardly to the extreme lowermost, and the movable cylinder is drawn up with the chuck when they rise until they reach the extreme uppermost position where the chuck is withdrawn from the cylinder and is clutched to the lead. The movable cylinder has an inwardly projecting rim which as it rises abuts the lead protecting tube thereby raising the lead protecting tube to a position inside the pencil proper. Two coil springs varying in thickness and length are provided, the longer one functioning for propelling the lead and the shorter one functioning for withdrawing the lead.

5 Claims, 9 Drawing Figures

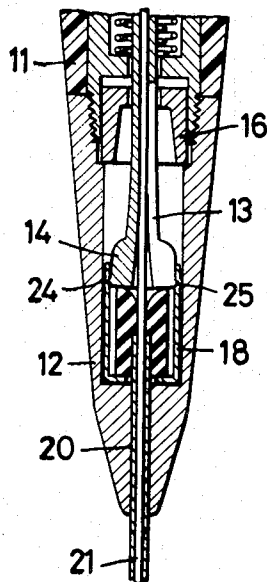

FIG. 1

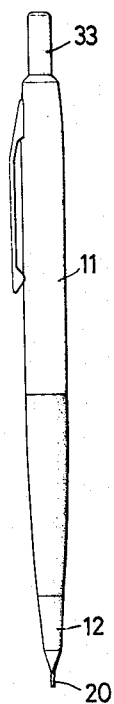

FIG. 2

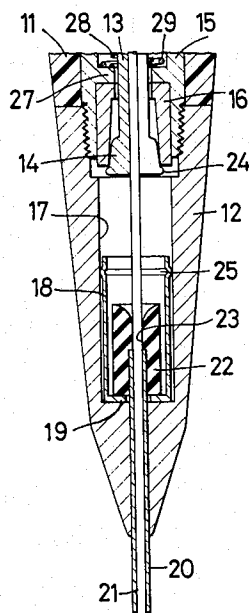

FIG. 3

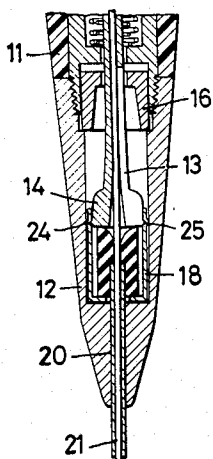

FIG. 4

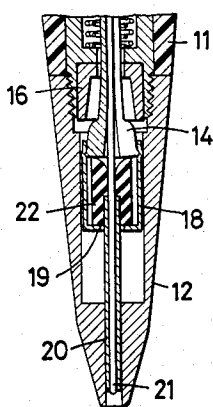

FIG. 5

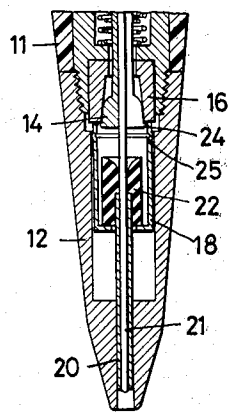

FIG. 6

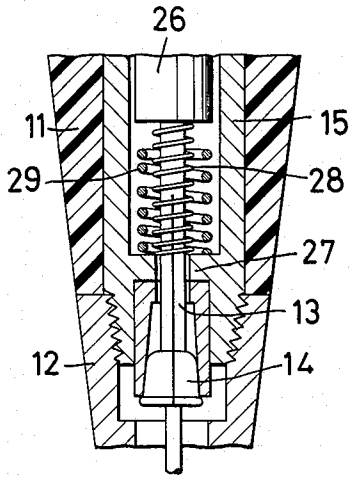

FIG. 7

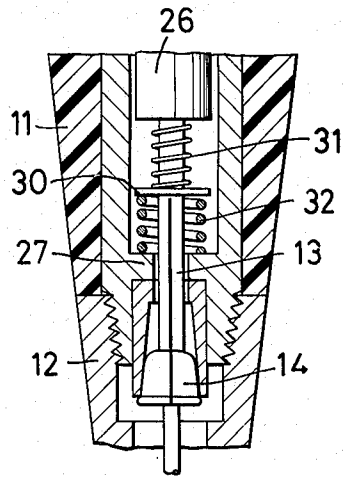

FIG. 8

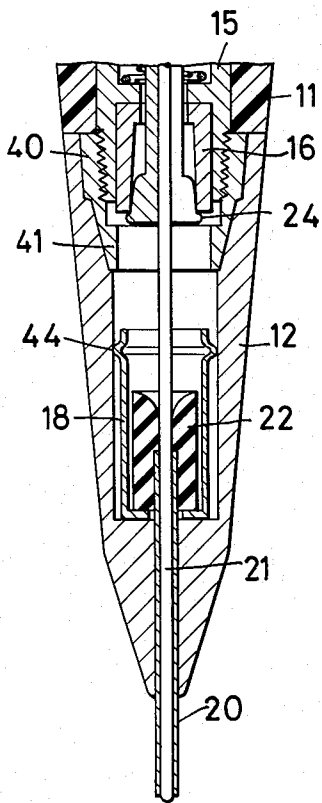
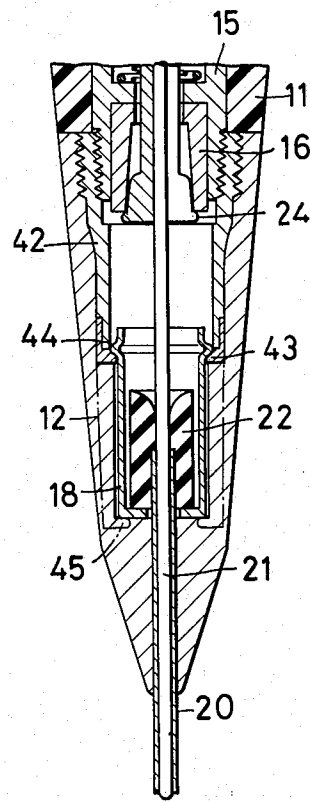

FIG. 9



MECHANICAL PENCIL

The present invention relates to a mechanical pencil characterized by having a system enabling advancement of the lead by applying repeated pressure to an actuating cap until the lead is stopped at a predetermined point suitable for writing and which further withdraws the lead with a touch on the actuating cap, and in particular a mechanical pencil comprising two springs varied in strength or length for accomplishing the mechanism as above described.

In conventional mechanical pencils, finger pressure must be applied directly to the lead while at the same time pushing the actuating cap to withdraw the lead from its projected state as required for writing.

A main object of the present invention is to discard this troublesome operation for the lead as described above.

The main and other objects of the present invention can be accomplished by the improvement, combination and operation of every part constituting the present invention, the preferred embodiments of which are illustrated in relation with the annexed drawings as follows:

FIG. 1 is a front view of a mechanical pencil of the present invention in the first embodiment.

FIG. 2 is a magnified longitudinal section of integral parts of the above-described mechanical pencil.

FIG. 3 is a magnified longitudinal section of the integral parts of the lower end of the mechanical pencil showing the chuck fully extended and engaged with the movable cylinder.

FIG. 4 is a magnified longitudinal section of the integral parts of the lower end of the mechanical pencil showing the chuck engaged and the lead partially retracted within the pencil body.

FIG. 5 is a magnified longitudinal section of the integral parts of the lower end of the mechanical pencil showing the chuck and the lead fully retracted into the pencil body.

FIG. 6 is a magnified longitudinal section of the integral parts of the mechanical pencil showing a first embodiment of the biasing springs in the pencil body.

FIG. 7 is a magnified longitudinal section of the integral parts of the mechanical pencil showing a second embodiment of the biasing springs in the pencil body.

FIG. 8 is a magnified longitudinal section of the integral parts of the mechanical pencil showing a second embodiment of the lower end of the pencil.

FIG. 9 is a magnified longitudinal section of the integral parts of the mechanical pencil showing a third embodiment of the lower end of the pencil.

In FIG. 1, the pencil proper 11 has a lower terminal cylinder 12 said pencil proper 11 contains movably therein a lead container 26 (not shown in FIG. 2); a chuck 14 which is provided therein at the lower portion of a pipe 13 fixed below said lead-container, said pipe 13 being slidably fitted to a cylinder 15 fixed at the lower terminal of said pencil proper 11; and a slidable tube 16 which is adapted outside said chuck 14 so that said tube 16 can be detachably fitted to the lower half of said cylinder 15. With the lower half of said cylinder 15 projecting from the pencil proper 11 at the lower end thereof, a male screw at the outside of said cylinder 15 screws into a female screw provided at the upper inside of said terminal cylinder 12, thereby connecting said terminal cylinder 12 with the pencil proper 11.

Said terminal cylinder 12 has an inside periphery 17 formed below said female screw, said inside periphery 17 being a bit smaller in diameter than the outer diameter of said slidable tube 16 and larger to some extent than the chuck 14 in a loosened state. Within said inside periphery 17 there is inserted a movable cylinder 18 which is provided with an inward projecting rim 19 at the lower portion thereof.

At the forward tip of said terminal cylinder 12 there is adapted a lead protecting tube 20 the upper end of which is inserted in said movable cylinder 18. Said protecting tube 20 has at the upper end thereof a rubber tube 22 of a bigger diameter firmly fitting thereto, said rubber tube 22 having a penetration hole 23 which is a bit smaller in diameter than that of the lead 21 contained in said protecting tube 20.

Said chuck 14, consisting of a plurality of expandable claws, holds the lead by the inward pressure of said claws when said chuck 14 is placed within said slidable tube 16, and the chuck 14 loosens as it goes out of said slidable tube 16, thereby releasing the lead 21 from the clutch 14. Each of said claws has a projection 24 at the lower end thereof so that said projections 24 fit into a groove 25 provided in said cylinder 18 at the upper inside thereof as said chuck 14 enters therein, thereby firmly fixing said chuck 14 therewithin.

FIGS. 6 and 7 show embodiments of two-fold coil springs incorporated between a lead container 26 and said cylinder 15 at the inward projecting rim 27 thereof.

In FIG. 6, a coil spring 28 and another coil spring 29 varying in length are shown, the longer and thinner coil spring 28 coiling around the pipe 13 and the shorter and thicker coil spring 29 coiling around thereon. Said two springs 28, 29 can also be equalized in thickness but should be varied in length so that they may be different from each other in strength.

In FIG. 7, a base metal member 30 is shown provided movably in said pipe 13 in between both ends thereof, said base metal member 30 having at the upper portion thereof a weaker coil spring 31 and at the lower portion thereof a stronger coil spring 32. The positions of said coil springs can be inverted also.

The above-mentioned lead container 26 is capped detachably at the upper terminal thereof with an actuating cap 33 projecting from the pencil proper 11 at the upper opening thereof as shown in FIG. 1, said lead container 26 being stably fixed inside the pencil proper 11 with a stopper provided therein preventing said lead container 26 from sliding off.

In the present invention as referred to heretofore, a light push on said actuating cap 33, designated in FIG. 1, forces said lead container 26 downward thereby compressing said coil spring 28 or 31. The pipe 13 and the lead container 26 come down together as a matter of course. At this time, the chuck 14 at the lower terminal of said pipe 13 is within said slidable tube 16 and is in a closed state clutching the lead therein. Said chuck 14 continues to go down under pressure of said pipe 13 even after said slidable tube 16 stops as it hits the inside periphery 17 at the upper terminal thereof, thereby separating said chuck 14 from said slidable tube 16 and loosening said chuck 14, and thereby releasing the lead 21 from its clutch. Upon release of said actuating cap 33 from the pushing pressure, said chuck 14 returns separately from the lead 21.

By repeating the above-described operation the lead 21 gradually descends followed by the descent of said lead protecting tube 20 under the effect of a friction between the lead 21 and the rubber tube 22 of said lead protecting tube 20 at the penetration hole 23 thereof.

When the lead protecting tube 20 and the lead 21 project out of the pencil proper, as shown in FIG. 2, a strong push on said actuating cap 33 brings said lead container 26 downward thereby pressing said coil springs 28, 29 or 31, 32 downward to a great extent, thereby continuing to force the said chuck 14 downward, even after it separates from the slidable tube 16 and releases the lead 21, until it goes into the movable cylinder 18 as shown in FIG. 3. The projection 24 of said chuck 14 then abuts said groove 25 formed inside said movable cylinder 18. When said actuating cap 33 is released from the strong push, said lead container 26 is bounced back by the coil springs 28, 29 or 31, 32, whereby the chuck 14 also rises together with the movable cylinder 18. The raising of said movable cylinder 18 with its inward projecting rim 19 at the lower end thereof pressing upward against said rubber tube 22 results in the raising, i.e., withdrawing, of said lead protecting tube 20 and the lead 21 into the pencil proper.

Although the chuck 14 is in a loosened state and the lead 21 is free from the chuck accordingly, the lead 21 draws back under the effect of friction between itself and the rubber tube 22 at the penetration hole 23 thereof.

The chuck 14 continues to rise even after said movable cylinder 18 stops when it hits said slidable tube 16 at the lower end thereof, thereby causing said chuck 14 to detach from said movable cylinder 18 as it is inserted into said slidable tube 16. Said chuck 14 thereby tightens and clutches the lead 21 as the result.

As described heretofore, the mechanical pencil in the present invention is characterized by the simplification of operation and availability for effectively using the lead without fail. The lead and the lead protecting tube 20 come to a forced stop when the lead reaches a predetermined projecting length suitable for writing following a light pushing of the actuating cap, and a stronger pushing of the actuating cap thereafter brings up the lead into the pencil proper as mentioned hereinbefore.

In the above described embodiments, the mechanism of "a projection 24 abutting on a groove 25" can be dispensed with by means of taking advantage of a friction between the chuck 14 of its outside and the movable cylinder 18 at its inside periphery.

FIGS. 8 and 9 show how to prevent the movable cylinder 18 from detaching from the terminal cylinder 12 when removing the terminal cylinder 12 from the pencil proper 11.

In FIG. 8, another cylinder 40 is unmovably but detachably fixed to the terminal cylinder 12 at the upper inside thereof, and a female screw of said cylinder 40 is fitted with a male screw of said cylinder 15. Said cylinder 40 also has an inward projecting rim 41 at the inside lower terminal thereof, said inward projecting rim 41 being smaller in diameter than the movable cylinder 18 at its outside projecting rim 44, thereby preventing separation of said movable cylinder 18.

In case repairs are necessary, the movable cylinder 18 can be removed from the lower terminal portion 12 by removing the detachably-fixed cylinder 40 therefrom.

In FIG. 9, a male screw at the lower end of the cylinder 15 fixes with a female screw of a cylinder 42 at its upper terminal, and the cylinder 42 has at its lower end an inward projecting rim 43 which abuts the projecting rim 44 of the movable cylinder 42 being surrounded by the terminal cylinder 12 with a male screw of the cylinder 42 at its outside screwing into a female screw of the lower terminal portion 12 at its upper inside terminal. In this structure, the movable cylinder 18 can be easily removed by means of separating the terminal portion 12 from the cylinder 15. The cylinder 42 can also abut on the movable cylinder 18 by means of providing an inward projecting rim 45 in the cylinder 42 at the lower terminal thereof with an extension of length given thereto.

What is claimed is:

1. An automatic lead pencil having a pencil body with a terminal tubular end portion at the forward end of said pencil body when said pencil is pointed downward and wherein said lead can be made to extend from and retract into said end portion comprising:

lead containing means within said pencil body for containing lead used in said pencil;

expandable chuck means connected to and below said lead containing means when said pencil is pointed downward for clutching lead coming from said lead containing means;

actuating means extending above said pencil body when said terminal end is pointed downward and operatively connected to said lead containing means for forcing said lead containing means downward, thereby actuating said chuck means, causing said chuck means to expand and allow the lead to pass therethrough;

lead protecting means surrounding and frictionally holding the lead as the lead passes through and out of the terminal end of said pencil, said lead protecting means movably mounted within said terminal end extendable therefrom and retractable thereinto with the extension and retraction of the lead into and out of said pencil body;

two springs within said pencil body positioned for biasing said lead containing means upward when said pencil is pointed downward, one of said springs being of lesser biasing strength than the other and positioned for being actuated by said actuating means before said stronger spring of the two is actuated, whereby depressing said actuating means with sufficient force to depress and actuate only the weaker of said two springs will cause said chuck means to advance to a first position below said lead containing means while clutching said lead, then advance further, expand and release said lead, thereby moving said lead downward a predetermined length from said lead containing means into and through said lead protecting means and out of said pencil, and whereby releasing said actuating means will cause said spring to expand, drawing said lead containing means and said chuck means upward, thereby causing said chuck means to close and grasp said lead once again;

slidable retracting means elevatably and freely fitted within said terminal end for holding said lead protecting means and for engaging with said chuck means when said chuck means is fully extended and expanded, whereby depressing said actuating means with sufficient force to first compress the

5

weaker spring and then the stronger spring will cause said chuck means to fully extend to a second position and engage with said retracting means and whereby releasing said actuating means will cause said springs to expand, drawing said lead containing means, said chuck means attached to said lead containing means, and said retracting means engaged with said chuck means upward, thereby withdrawing said lead protecting means and said lead within said lead protecting means into said pencil body.

2. An automatic pencil as claimed in claim 1 wherein said slidable retracting means is comprised of:

a hollow cylinder slidably fitted within the terminal end of said pencil body having an outwardly expanded rim at the upper part thereof when the pencil is pointed downward for engaging with said chuck means and having an inwardly projecting rim at the bottom thereof when said pencil is pointed downward adapted to fit and retain therein said lead protecting means; and

a rubber tube of larger diameter than said lead protecting means for fitting around and holding said lead protecting means within said hollow cylinder and having a hole therethrough for allowing said lead to pass therethrough to said lead protecting

6

means from said lead containing means, said hole being of small enough diameter to frictionally hold said lead therein, whereby advancing said lead downward when said slidable retracting means is withdrawn inside the pencil body will cause said slidable retracting means to move downward within the pencil body due to the frictional attraction between the rubber tube and the lead passing therethrough.

3. A pencil as claimed in claim 1 wherein said two springs are positioned surrounding the upper portion of said chuck means where said chuck means is connected to said lead containing means.

4. A pencil as claimed in claim 3 wherein said two springs are positioned concentric with each other around the upper portion of said chuck means, and said weaker spring is of greater length than said stronger spring.

5. A pencil as claimed in claim 3 wherein separating means is positioned around the upper portion of said chuck means between said two springs for separating said springs, said weaker spring being on one side of said separating means and said stronger spring being on the other side.

* * * * *

30

35

40

45

50

55

60

65