

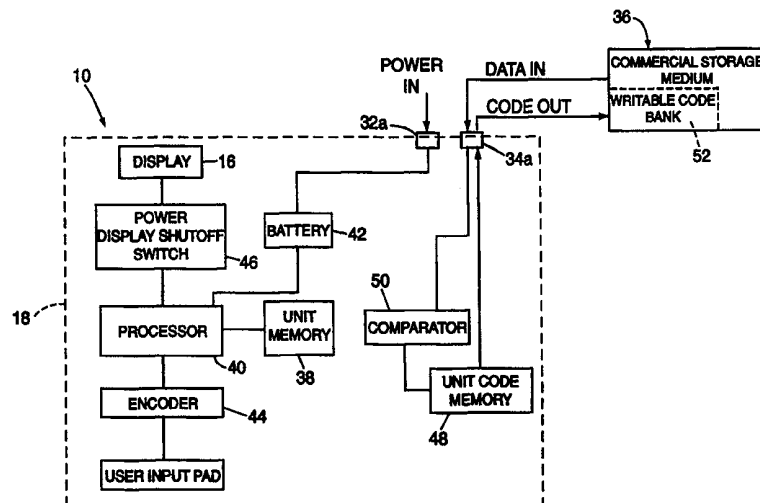

INTERNATIONAL APPLICATION PUBLISHED UNDER THE PATENT COOPERATION TREATY (PCT)

<p>(51) International Patent Classification ⁶ : H01G 4/38, G06F 12/00, 13/00</p>	<p>A1</p>	<p>(11) International Publication Number: WO 99/24994</p> <p>(43) International Publication Date: 20 May 1999 (20.05.99)</p>
<p>(21) International Application Number: PCT/US98/24361</p> <p>(22) International Filing Date: 10 November 1998 (10.11.98)</p> <p>(30) Priority Data: 08/966,511 10 November 1997 (10.11.97) US</p> <p>(71)(72) Applicant and Inventor: GASTON, Kerry [US/US]; 2474 Aberdeen Drive, Montgomery, AL 36116 (US).</p> <p>(74) Agents: BELUSH, Thomas, A. et al.; Leydig, Voit & Mayer, Ltd., Two Prudential Plaza, Suite 4900, 180 North Stetson, Chicago, IL 60601-6780 (US).</p>		<p>(81) Designated States: AL, AM, AT, AU, AZ, BA, BB, BG, BR, BY, CA, CH, CN, CU, CZ, DE, DK, EE, ES, FI, GB, GE, GH, GM, HR, HU, ID, IL, IS, JP, KE, KG, KP, KR, KZ, LC, LK, LR, LS, LT, LU, LV, MD, MG, MK, MN, MW, MX, NO, NZ, PL, PT, RO, RU, SD, SE, SG, SI, SK, SL, TJ, TM, TR, TT, UA, UG, UZ, VN, YU, ZW, ARIPO patent (GH, GM, KE, LS, MW, SD, SZ, UG, ZW), Eurasian patent (AM, AZ, BY, KG, KZ, MD, RU, TJ, TM), European patent (AT, BE, CH, CY, DE, DK, ES, FI, FR, GB, GR, IE, IT, LU, MC, NL, PT, SE), OAPI patent (BF, BJ, CF, CG, CI, CM, GA, GN, GW, ML, MR, NE, SN, TD, TG).</p> <p>Published <i>With international search report.</i> <i>Before the expiration of the time limit for amending the claims and to be republished in the event of the receipt of amendments.</i></p>

(54) Title: ELECTRONIC BOOK SYSTEM



(57) Abstract

An electronic book system including a portable display (16) unit and a mated downloading stand (60) which receives the unit in a plug-in manner so that data and ports (32a, 34a) of the unit mutually connected with respective data and power connectors of the stand (132, 134). Upon insertion, data is downloaded to a memory (48) in the unit when a data signal is supplied through the data port. The display device has a tubular shaped housing with a display screen (16) and control buttons applied to a front planar surface of the housing. The stand is modularly designed to be stacked adjacently with additional like stands in mated connection with each other for common data and power communication (32a, 34a). A system for preventing unauthorized use of stored book data is also provided wherein each unit is assigned a unique electronic code value (52), and wherein the book data on a particular storage medium (36) may be initially accessed by any coded unit, but wherein subsequently access by other units is denied.

FOR THE PURPOSES OF INFORMATION ONLY

Codes used to identify States party to the PCT on the front pages of pamphlets publishing international applications under the PCT.

AL	Albania	ES	Spain	LS	Lesotho	SI	Slovenia
AM	Armenia	FI	Finland	LT	Lithuania	SK	Slovakia
AT	Austria	FR	France	LU	Luxembourg	SN	Senegal
AU	Australia	GA	Gabon	LV	Latvia	SZ	Swaziland
AZ	Azerbaijan	GB	United Kingdom	MC	Monaco	TD	Chad
BA	Bosnia and Herzegovina	GE	Georgia	MD	Republic of Moldova	TG	Togo
BB	Barbados	GH	Ghana	MG	Madagascar	TJ	Tajikistan
BE	Belgium	GN	Guinea	MK	The former Yugoslav Republic of Macedonia	TM	Turkmenistan
BF	Burkina Faso	GR	Greece	ML	Mali	TR	Turkey
BG	Bulgaria	HU	Hungary	MN	Mongolia	TT	Trinidad and Tobago
BJ	Benin	IE	Ireland	MR	Mauritania	UA	Ukraine
BR	Brazil	IL	Israel	MW	Malawi	UG	Uganda
BY	Belarus	IS	Iceland	MX	Mexico	US	United States of America
CA	Canada	IT	Italy	NE	Niger	UZ	Uzbekistan
CF	Central African Republic	JP	Japan	NL	Netherlands	VN	Viet Nam
CG	Congo	KE	Kenya	NO	Norway	YU	Yugoslavia
CH	Switzerland	KG	Kyrgyzstan	NZ	New Zealand	ZW	Zimbabwe
CI	Côte d'Ivoire	KP	Democratic People's Republic of Korea	PL	Poland		
CM	Cameroon	KR	Republic of Korea	PT	Portugal		
CN	China	KZ	Kazakstan	RO	Romania		
CU	Cuba	LC	Saint Lucia	RU	Russian Federation		
CZ	Czech Republic	LI	Liechtenstein	SD	Sudan		
DE	Germany	LK	Sri Lanka	SE	Sweden		
DK	Denmark	LR	Liberia	SG	Singapore		
EE	Estonia						

ELECTRONIC BOOK SYSTEM

BACKGROUND

The present invention relates to hand-held display devices and more particularly relates to a system having a portable electronic book display unit and an associated power and data transfer stand.

Electronic books are disclosed, for example, in U.S. Patents 4,445,196, 4,855,725, 4,985,697, and 5,475,398. An improved electronic book system is needed, however, which meets the needs of everyday book readers. In particular, an electronic book system is needed which provides a convenient and inexpensive book display unit which is durable and resistant to a typical environment for reading, such as at the beach or pool. Additionally, a need exists for a system which facilitates the protection of text data offered for use in electronic display units. Moreover, a need exists for a system that permits the convenient battery recharging and data downloading into an electronic display unit.

SUMMARY OF THE INVENTION

The present invention meets the aforementioned needs by providing an improved electronic book system. In particular, the invention provides a hand-held portable display unit that receives and stores an amount of data and electronically displays such data in a page-like format generally resembling a page of a conventional book. The display unit has a size and shape comparable to the convenient size of a paperback book and permits a user to select a desired portion of text to be displayed, such as by advancing "pages" forward or backward.

The display unit preferably has a durable housing which holds a generally page-shaped display screen. The housing is formed to have ergonomically-shaped side portions with thumb-shaped frontal depressions for comfortable gripping. Control buttons are mounted along at least one of the side portions for easy manipulation by a users thumb. The housing is preferably formed from a soft material to enhance comfort, durability, and resistance to water, sand, drinks, etc.

The soft characteristic of the housing protects the unit from shocks and impacts. Alternatively, the housing could be formed of multiple layers, having at least one layer formed of such a soft material.

The display device is battery-powered and includes a memory which receives
5 text downloaded from a computer or from a separate loading device. For
conveniently loading data into the memory and recharging the battery, the electronic
book system includes a stand adapted to receive the display unit. This stand has a
base with side-mounted power input port connectable to a power supply and data
input port connectable to a data source, such as a parallel port of a PC. The stand
10 may be connected to an intermediate switching device to eliminate a need to allocate
a parallel port dedicated to this function. The PC delivers the book data to the stand
from any appropriate storage medium, such as a diskette, compact disc, a hard
drive, or even from a source accessible over a modem or the Internet. The stand
and book device have a pair of correspondingly matable plug connectors for
15 respectively providing power supply and data line communication to the display unit
when the display unit is inserted into the stand.

The stand has a modular design with corresponding male and female data and
power input ports mounted at opposite sides and which are through-connected. This
facilitates a side-by-side stacking of the multiple stands so that the mated power and
20 data ports of adjacent stands are connected together, permitting battery recharging
and data downloading of multiple display units simultaneously.

In an alternative embodiment which eliminates a need for downloading, the
system can include modular memory cartridges for storing discrete amounts of book
data. For example, book data can be stored on a ROM chip or other appropriate
25 storage medium housed in a cartridge that is adapted to be plugged into a mated
receptacle on the display unit. Such a system would permit publishers to offer a
particular book or novel stored on a plug-in cartridge for reading on the electronic
display unit. Solid state technology is preferred in order to maximize reliability and
minimize cost of the system, but the display unit could also be provided with a disc
30 reader to display data provided on magnetic or laser disc storage media.

For protecting book data from unauthorized copying, the electronic book system of the invention also provides a coding system that permits a one-time accessing of the data or which permits access from a particular display unit which first receives the data. More specifically, each display device may have a code
5 programmed therein that distinguishes it from all other display devices. If a user purchases a novel in disc form for downloading from a PC, or in the form of a plug-in memory cartridge, the system automatically stores the particular unit's code on the disc or memory chip. After the first use, if a comparator in the display unit detects that the disc or cartridge already contains a different code, the processor
10 restricts the use of the data or restricts loading of the data into memory.

BRIEF DESCRIPTION OF THE DRAWINGS

FIG. 1 is a perspective view of an electronic display unit constructed in accordance with teachings of the present invention;

15 FIG. 2 is a front elevational view of the display unit shown in FIG. 1;

FIG. 3 is a schematic view of a display unit according to an embodiment of the invention configured for receiving and storing downloaded data;

FIG. 4 is a flowchart illustrating an exemplary operation of the coding system according to the invention;

20 FIG. 5 is a schematic view of a display unit according to the invention configured for receiving a modular data storage cartridge;

FIG. 6 is a partial exploded perspective view of a display unit and associated stand of the present invention;

25 FIG. 7 is a left-side view of a plurality of stands shown in a stacked and interlinked manner; and

FIGS. 8 is a perspective view of a data loading device of the present invention.

DETAILED DESCRIPTION OF THE PREFERRED EMBODIMENTS

Now referring to the Figures, wherein like numerals designate like parts, FIGS. 1 and 2 illustrate a hand-held portable display unit 10 constructed in accordance with the teachings of the present invention. The display unit 10 includes a housing 18 which holds a display screen 16 to display text. The screen 16 can be any suitable display, such as an LCD display or plasma display. Preferably, the screen 16 is about 6 ½ inches by 6 ½ inches.

So that the unit 10 is convenient for reading, the housing 18 is generally book-sized, as viewed toward the screen 16, preferably having a width (w) of about ten inches, a height (h) of about 7 ½ inches, and a thickness (d) of about one inch. At opposite sides of the screen 16, the housing 18 is ergonomically formed with thumb-shaped indentations 20, 22 to comfortably receive a user's thumbs (not shown) when the device is held, permitting comfortable elevation of the device 10 such as during nighttime reading. Further indentations (not shown) for the fingers or palms may be incorporated in the design. The depressions 20, 22 assist the user to hold up the display device 10, especially during prolonged reading, by lessening gripping fatigue in a user's hand.

The housing 18 is preferably formed of a material that provides a slight cushioned feel. For example, the housing 18 may be constructed of various polymers or thermoplastics that slightly yield or flex under pressure, or the housing 18 may otherwise include multiple layers wherein an outer layer is a rubber-like or foam material. The cushioning effect adds comfort for a reader and also protects the display unit 10 from being damaged by an accidental impact.

As illustrated in FIGS. 1 and 2, a user input pad comprising a plurality of control buttons are mounted in a spaced manner along a side of the housing 18 above one of the thumb indentations. These buttons operate various display functions, and preferably include an on/off button 24, menu button 26, back button 28, and a screen/select button 30. These buttons operate the unit 10 as described below:

1) "On/off" button 24. This button 24 turns the unit 10 on and causes a selected displayed screen to be electronically marked or remembered when the unit 10 is turned off. Like a bookmark, the last-displayed screen reappears when the unit 10 is turned on again. When a book is turned on for the first time, then the
5 first screen of the book is displayed.

2) "Screen/Select" button 30. This button 30 is placed just above and to the side of the thumb indentation 22. Its precise location depends on the design and the comfort of the user, and could actually be inside the thumb indentation 22. When the screen/select button 30 is depressed, the display 16 advances to the next screen
10 of the book. The screen/select button 30 is also used for selecting a displayed menu option, as explained below in connection with the menu button 26.

3) "Back" button 28. Pressing this button 28 causes the display to move one screen or "page" at a time back through the book.

4) "Menu" button 26. Pressing this button causes a menu to be displayed
15 on the screen which lists a variety of control options. Repeatedly pressing the "Menu" button causes a cursor or highlighter to skip from one option in the list to the next, and a desired option may then be selected by the "Screen/Select" button. An exemplary list of menu options is as follows:

a) "Text size" option. When selected, the screen displays a choice
20 of text sizes from small to large. By again selecting this in a repeated manner, the user can sample the range of text sizes. The preferable text size can then be selected by pressing a "screen/select" switch.

b) "Brightness" option. Selection of this option allows for darkening or lightening the screen.

25 c) "Bookmark" option. If the user wants to place a bookmark on a particular screen, selecting this option will mark the currently displayed screen.

d) "Find" option. Selection of this option allows the user to go to a specific location in the book. For example, by selecting this option and using the "screen/select" button, the user control the display to go to a screen at the beginning
30 of the book, the end of the book, specific chapters or parts of the book (such as the

“forward” or “index”), previously marked screens, or to a specific screen or “page”. An added feature is that the user can conveniently go to the text for any reference in the index.

5 e) “Status” option. Selection of this option causes displays various information about the book data or the system. For example, the display may indicate the total number of pages in the book, battery level, etc.

f) “Which Book” option. In an embodiment wherein multiple volumes are accessibly stored, this option permits selection of an available book.

10 g) “Exit” option. Selection of “Exit” exits the menu selection screen.

Various other menus and options can be provided to facilitate desired control operations. If multiple menus are available, pressing the “Back” button causes the display to return to a previous menu selection.

15 Other embodiments may include optional features such as a left-handed models, models that have thumb and finger indentations which are custom-fit to a particular user’s hands, models having a variety of sizes and colors, models capable of responding to audible input (e.g. “turn page”) or providing audible output, such as automatically “reading” a book aloud, a receiver, such as for taking orders, e.g., “turn page”, and as a sender such as for reading the book out loud. The display
20 may animate a “page turning” effect each time the “screen/select” or “back” button is pressed. Information such as page number, title, of chapter headings, etc., can also be displayed placed on each screen of text or illustration data. Also, the unit may be equipped with an optional solar cell for recharging the battery in sunlight.

To permit connection of the unit 10 to power and data supply lines, a power
25 port 32 and a data port 34 are located at a left side of the housing 18, as shown in FIG. 1. Each of the ports 32, 34 is an appropriate type of plug connector, such as a type having pin receptacles (not shown). These ports 32 and 34 are preferably positioned at the same side of the unit 10 for convenient connection during which battery power is recharged and data is loaded as described below in connection with
30 FIGS. 6 and 7.

Now turning to FIG. 3, the display unit 10 is shown with a data source 36, which, as illustrated, is a commercial storage medium. Basically, the display unit 10 illustrated in FIG. 3 is configured to receive and store book data which may be downloaded from a personal computer (PC) or other loading device (discussed in
5 greater detail below in connection with FIGS. 7 and 8) which can access information from the data source 36 from an appropriate drive or reading device, such as from a disk drive. Accordingly, the data source 36 may be a locally-stored medium such as a CD-ROM, a magnetic diskette, a tape, etc., which is read and delivered via the PC or other loading device (as described in connection with FIGS. 7 and 8), or the
10 data source may be accessed through a network, such as the Internet. A publisher may offer many book selections available on the same type of commercial storage medium, each of which may store data for one or more books.

Among other components, the unit 10 has an internal memory 38, a processor 40 and a battery 42 mounted within the housing 18. The data is delivered
15 to the unit 10 through the data port 34 to the internal memory 38 which accessibly stores the data until purged, erased, or overwritten by loading different data at a later time. The memory 38 may be, for example, a conventional RAM chip. While the memory 38 may have a very large capacity, it may be desirable to provide the memory 38 with a limited capacity, (e.g., enough to store one typical long
20 novel) in order to minimize the cost and size of the unit. Of course, it may be desirable to provide the memory with a capacity large enough to store several books at one time, so that the user has a choice of which volume to read. The memory 38 is preferably of a type that is overwritten each time a new book is downloaded. Also, the memory 38 may be of a type which requires a small voltage to retain the
25 stored data.

The processor 40 receives the data from the memory 38 and also receives user input signals (corresponding to the above-described button operations) from the user input pad or control buttons 24, 26, 28, 30 via an appropriate encoder 44 which provide a predetermined signal for each of the buttons. The processor 40

determines an appropriate display for the conditions and delivers a display signal to the display 16.

The display screen 16 may be an LCD display, an LED display, a plasma display, a CRT, or some other appropriate type of display. Preferably, the display
5 screen 16 is of a type which is light-emitting or backlit when necessary for readably displaying in the dark.

The battery 42 provides power to the unit 10 for its independent operation. The battery 42 may be any type of a suitable size and weight with a suitable voltage and capacity to sustain operation of the unit 10 for a desirable amount of reading
10 time. The battery 42 is preferably rechargeable and is configured to receive a recharge voltage from the power port 32. In order to prolong the life of the battery 42, the processor 40 is preferably programmed to control the display with a predetermined power management features. For example, the processor 40 may be programmed such that if no user input signal is received after a predetermined
15 period of time, the display 16 will be shut down by a powersaving display shut-off switch 46. In embodiments where the memory 38 requires a voltage for data storage, the battery 42 provides a constant voltage to the memory 38.

In an optional embodiment, the unit may have an appropriate pressure sensitive touch input screen (not shown) which allows a user to make "notes" on the
20 displayed book text or in the margin. In such a unit, the memory 38 is of a type that erasably stores the written input for subsequent display.

For preventing the unauthorized dissemination of copyrighted material, the electronic book system of the invention includes a coding system for limiting the use of data of the commercial storage medium 36. For example, the coding system may
25 restrict the downloading of data to only one individual display unit 10 or to a limited number of display units 10. This is facilitated by providing each unit 10 with a unit code memory 48 that stores a unique code value, a comparator 50, and by providing each commercial storage medium 36 (such as a diskette) with a writable memory bank 52. FIG. 4 shows an exemplary program to execute the protection function of
30 the coding system in the following manner. The first time that the commercial

storage medium 36 is accessed to download data to the unit 10, the comparator 50 receives a signal corresponding with a value stored in the code bank 52, as illustrated in FIG. 3. If the code bank 52 is empty (e.g. storing a code bank value of some predetermined value such as zero) the comparator 50 recognizes that there is a differential between the code bank value and the unique unit code value stored in the unit code memory 48. The unit 10 then sends the unit code value to the writable code bank 52 where the value of the unit code memory is permanently stored. The book text and/or illustration data is then downloaded into the unit memory 38 for authorized display of the data with the unit 10.

10 The owner of a particular unit 10 may continue to re-download data to the internal memory 38 from a previously-viewed book stored on specific commercial storage medium 36. At this subsequent downloading from the same commercial storage unit 36, the comparator 50 recognizes that the values stored in the code bank 52 and unit code memory 48 are identical, and access to the data is permitted for
15 downloading. The coding system, however, prevents a subsequent downloading of data from the commercial storage medium 36 when attempted by another unit 10 having a different unit code value. The comparator 50 recognizes that a value had previously been written to the code bank 52 and that a difference exists between the values stored in the code bank 52 and the unit code memory 48, and access to the
20 data is denied. The display screen 16 is caused to display an appropriate message.

 As shown in FIG. 5, a display unit 10' is illustrated which operates in substantially the same manner as described above, except that the data source or commercial storage medium is in the form of a modular memory cartridge 36' containing an appropriate memory chip that contains a read-only memory portion
25 containing the book data and preferably also containing a writable memory portion forming a code bank 52'. Alternatively, the cartridge 36' may be a disk, tape, or some other medium with an appropriate reader contained in the unit. In the embodiment shown in FIG. 5, the unit 10' is configured to pluggably receive and removably hold the memory cartridge 36', which remains plugged into the unit 10'
30 during the period of portable display use of its data. This embodiment eliminates a

need to perform a downloading operation from a loading device, like a PC. A need is also eliminated for a dedicated internal data memory, such as the internal memory 38 of the portable display unit 10 illustrated in FIG. 3, however, the embodiment of FIG. 5 could contain an internal data memory if desired. The memory cartridge 36' also contains a writable code bank 52' to restrict its use in the manner described above in connection with FIGS. 3 and 4.

The system invention of the invention also provides a structure for conveniently downloading new data into an internal memory of the portable display unit 10 and simultaneously recharging the battery 42. Accordingly, FIG. 6 illustrates a downloading stand 60 which is configured to slidably receive the display unit 10 in mated connection with the ports 32a, 34a of the portable display unit 10. The structure of the downloading stand 60 facilitates a convenient connection to the ports 32a, 34a for delivering electricity and a data signal to the unit 10.

The stand 60, as shown in FIG. 6, has three upstanding walls 64, 66, 68 and a floor 70 above a base 71, defining an internal cavity 72 shaped to closely receive the unit 10. To provide connectability to external sources for data and electrical power, a power input socket 132 and a data input socket 134 are located in the wall 64 and are externally accessible from a side of the stand 60. The power and data input sockets 132, 134 may be of a pin receptacle type (not illustrated in detail). Within the cavity 72, a power connector 32b and data connector 34b are mounted in an upstanding fashion on the floor 70 of the stand 60 to correspondingly mate with the power port 32a and data port 34a of the portable unit 10 when it is inserted into the stand 60. The power connector 32b and data connector 34b are respectively connected with the power socket 132 and data socket 134 to transfer power and data to the unit 10 from the external data and power sources, as discussed in greater detail below in connection with FIG. 7.

Another feature according to the invention permits convenient downloading and recharging of multiple portable display units 10 simultaneously. This may be useful, for example, in a classroom or library where multiple portable display units 10 are to be downloaded with the same book data. Accordingly, still referring to

FIG. 6, the stand 60 further includes an power output socket 232 and a data output socket 234 mounted in the base 71 opposite of the input sockets 132, 132. These sockets 232, 234 are respectively connected to receive pass-through communication of voltage and data from the input sockets 132, 134. Turning to FIG. 7, the stand 5 60 is formed in a modular fashion to be stackable in a side-by-side arrangement with other stands 60, so that the output sockets 232, 234 are in mated connection with the respective input sockets 132, .134 of an adjacent stand 60. Thereby, the multiple stands 60 are in like data and power communication with each other and with the external data source and power source.

10 The data socket 134 is configured to receive a cable from the external data source, such as a PC 95, as illustrated in FIG. 7, or another suitable downloading device for downloading a text and/or illustration file into the display device 10 residing in the stand 60. The power socket 132 is connectable to a voltage source via a power cable with a plug 106 that is insertable into the socket 132, such as an 15 AC/DC transformer 100 having an output appropriately matched to the battery 42 (FIG. 3) of the display unit 10. Thereby, the battery 42 is recharged when the portable display unit 10 is inserted into the stand 60. The transformer 100 may be a conventional type which has a plug 102 that is insertable into a conventional AC wall socket (not shown). Alternatively, the stand 60 may be configured to integrally 20 include a transformer (not shown). Additionally, the stand 60 may be provided with an aesthetically pleasing cover for a permanent freestanding display near the PC, on a library or school shelf, or other location. FIG. 7 shows four stands 60 stacked together, permitting downloading and recharging of four display units 10 via the data input socket 134 and power input socket 132 of an endmost one of the stands 25 60.

So that unused data and power output sockets 232, 234 do not inconveniently protrude from an individual or endmost stand 60 (such as that at the far left of FIG. 7), these sockets 232, 234 may be combined into a removable plug-in number 200, as shown in FIG. 7, which is removable to provide a flush surface at side 68. The 30 plug-in member 200 can be provided with the unit or sold separately. When the

plug-in member 200 is not being used, it may be removed and replaced by a plug 201.

FIG. 7 also illustrates PC 95 used as the downloading device to deliver data to the stand for writing to the internal memory of each of the units 10. The PC is preferably provided with a software that controls the downloading of data from a data source, providing the user a choice as to the data (book text) to be downloaded into the display devices 10 and from which source the book file is to be retrieved, i.e. a disk drive, CD-ROM drive or some other path. A data cable 90 is connected into the input data socket 134 of the stand 60 to deliver the data signal. As illustrated, the data cable 90 is connected to a switching device 92 which is connected to the parallel port of the PC by a cable 93 to transfer the data signal. The switching device 92 permits the parallel port 94 switchably shared among other devices, such as the device 96 when the PC is not downloading data to the stands 60. Alternatively, the socket data cable 90 may be connected directly to a parallel port 94 of the PC. When the user selects a file to be downloaded via the aforementioned software, the computer downloads the selected data to the display unit(s) 10 residing in the stand(s) 60. Also, the software may operate to detect the data already stored in the memory 38 of a particular display device and forewarn a user that a particular title is about to be overwritten. The software may then display a cancel option to abort the downloading.

In an embodiment wherein multiple stands 60 are used to download data selected display units 10, the stands 60 may be provided with a unique address code which is recognized by the PC to permit addressable downloading from the PC to a selected one or more of the stands 60. The software would prompt a user to indicate which stand should receive the data.

The system of the invention may also be provided with a loading device 120, such as the exemplary embodiment illustrated in FIG. 8, which facilitates downloading to a display unit 10 without the use of a PC. This permits the display unit 10 to be used by consumers who cannot afford a PC or for use of the system in applications where a PC is not otherwise needed. The loading device 120 has an

appropriate reading device, such as a disk drive, which accepts a disk (or other medium) through a slot 130. The device 120 has a set of control buttons 126 for selecting a loading function and a display screen 124 for displaying operation messages and a menu of downloading choices to the user. A data port 128 is
5 connectable to the data input socket 34 of the stand 60 or directly to the data port 34 of the unit 10 by an appropriate connector or cable. The downloading operation of the loading device 120 is performed in a similar manner to that described above in connection with the PC and may incorporate similar software.

While the invention is described herein in connection with certain preferred
10 embodiments, there is no intent to limit it to those embodiments. On the contrary, it is recognized that various changes and modifications to the described embodiments will be apparent to those skilled in the art, and that such changes and modifications may be made without departing from the spirit and scope of the present invention. Accordingly, the intent is to cover all alternatives, modifications, and equivalents
15 included within the spirit and scope of the invention as defined by the appended claims.

WHAT IS CLAIMED IS:

1. An electronic book system comprising:
a portable display unit including: a generally book-sized, rectilinear
housing; a frontal display screen held by said housing; a memory
5 contained within the housing for storing an amount of book data; a
user input pad; a processor controlling a display of said data on the
display screen in response to signals from said user input pad; and a
data port for delivering the book data to said memory; and
a downloading stand including: a plurality of walls defining a cavity to
10 slidably receive said display unit; a data connector mounted to one of
said walls, the data connector adapted to matably connect with the
data port of the display unit when the display unit is inserted into the
downloading stand; and a data input socket mounted to one of said
walls for external access from a side of the stand, the data input
15 socket connected in communication with the data connector and being
connectable to a downloading device to deliver data to the memory.
2. The electronic book system according to Claim 1, wherein the stand
further includes a data output socket connected in signal communication with said
20 data input socket and mounted to one of the walls oppositely directed from said data
input socket.
3. The electronic book system according to Claim 2, wherein the stand
is adapted to be stackable in a side-by-side manner with at least one additional
25 generally like stand, so that the data output socket of said stand is capable of
matably connecting with the data input socket of an adjacent additional said stand.
4. The electronic book system according to Claim 1, wherein said stand
is generally book-shaped and having at least one opening to said cavity, said data
30 connector being mounted to a floor positioned oppositely of said opening.

5. The electronic book system according to Claim 1, wherein said stand has at least two adjacent sides opening to said cavity.

5 6. The electronic book system according to Claim 1, wherein said portable display unit further includes: a battery held within said housing; and a power port mounted in said housing in electrical communication with the battery; wherein said stand further includes a power connector mounted to one of said walls near said data connector to matably connect with the power port of the display unit
10 when the display unit is inserted into the downloading stand; and wherein said stand further includes a power input socket mounted to said wall of said stand near said data input socket, said power input socket being connectable with a voltage source for recharging said battery.

15 7. The electronic book system according to claim 6, wherein the stand further includes a power output socket connected in electrical communication with said power input socket and mounted to one of the walls oppositely directed from said power input socket.

20 8. The electronic book system according to Claim 7, wherein the stand is adapted to be stackable in a side-by-side manner with at least one additional generally like stand, so that the power output socket of said stand is capable of matably connecting with a power input socket of an adjacent additional said stand.

25 10. The electronic book system according to Claim 1, wherein said housing contains thumb-shaped indentations near sides of said frontal display screen.

11. The electronic book system according to Claim 1, wherein said user input pad includes a row of buttons positioned in said housing along a side of said frontal display screen.

5 12. A stand adapted for connectably receiving a book-shaped electronic display unit having a memory, a data port in communication with said memory, a battery, and a power port in communication with said battery, the stand being configured for stackable positioning in a side-by-side manner with additional like stands, the stand comprising: a plurality of walls defining a cavity shaped to closely
10 receive a book-shaped unit; an opening to the cavity; a floor opposite the opening; a power connector and a data connector mounted to the floor and positioned to matably connect with a respective power port and data port of a unit inserted into said cavity; a power input socket and a data input socket mounted to one of said walls accessible from an exterior of said stand, said power input socket and data
15 input socket being connected in communication with the power connector and data connector, respectively; a power output socket and a data output socket mounted to one of said walls oppositely directed from the input sockets and accessible from an exterior of the stand, the power output socket and data output socket being respectively connected in communication with the power input socket and data;
20 wherein the output sockets are positioned to matably connect with input sockets of an additional like stand adjacently stacked against said stand.

13. An electronic book system comprising:
a storage medium storing book data;
25 a portable display unit adapted to read and display data from said storage medium; and
coding means permitting access and display of the data stored on the storage medium by said display unit and preventing access and display of the data when the storage medium was previously read by another display
30 unit.

14. An electronic book system according to claim 13, said storage medium including a book data memory portion and a code bank memory portion, the code bank memory portion storing a code bank value, the code bank value
5 initially being set at a predetermined initial value, and wherein said the portable display unit including a unit code memory storing a predetermined unit code value and a comparator comparing the code bank value with the unit code value,

wherein when the code bank value is at said predetermined initial value, a signal indicating the unit code value is delivered to the code bank and stored
10 thereafter as the code bank value, and

wherein the portable display unit can access the data when said code bank value is equal to the unit code value and wherein access to the data is prevented when the code bank value is not equal to the unit code value.

15 15. The electronic book system according to Claim 13, wherein said display unit further comprises a unit memory, and wherein said access is a downloading of data to the unit memory from an external device reading said storage medium.

20 16. An electronic book system according to Claim 15, wherein said storage medium is a diskette.

17. An electronic book system according to Claim 13, wherein said storage medium is a cartridge with a memory chip, the cartridge being removably
25 insertable into said housing.

18. An electronic book system according to Claim 13, wherein said portable display unit includes a generally tabular-shaped, book-sized housing, and a display screen positioned at a front of said housing.

19. An electronic book system according to Claim 13, wherein said unit includes two thumb-shaped indentations in said housing positioned generally at opposite sides of said display screen.

FIG. 1

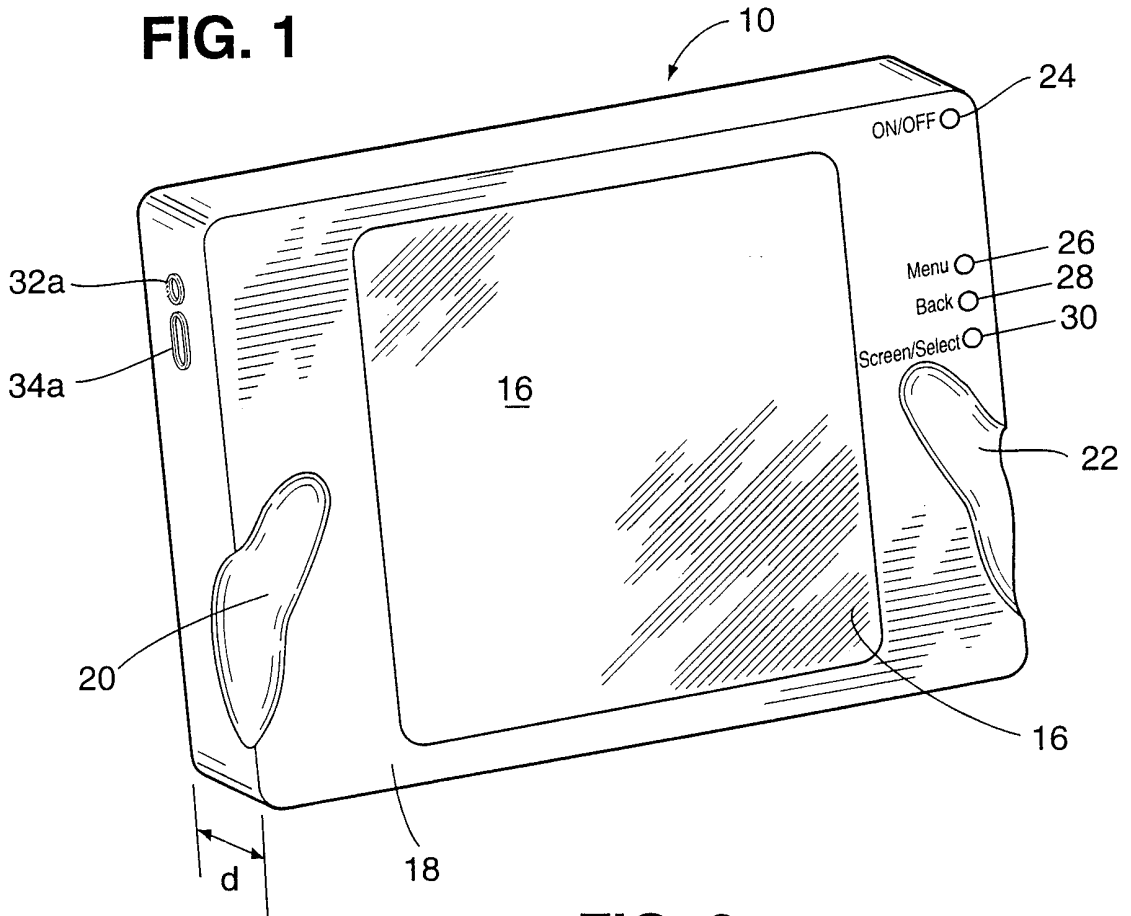
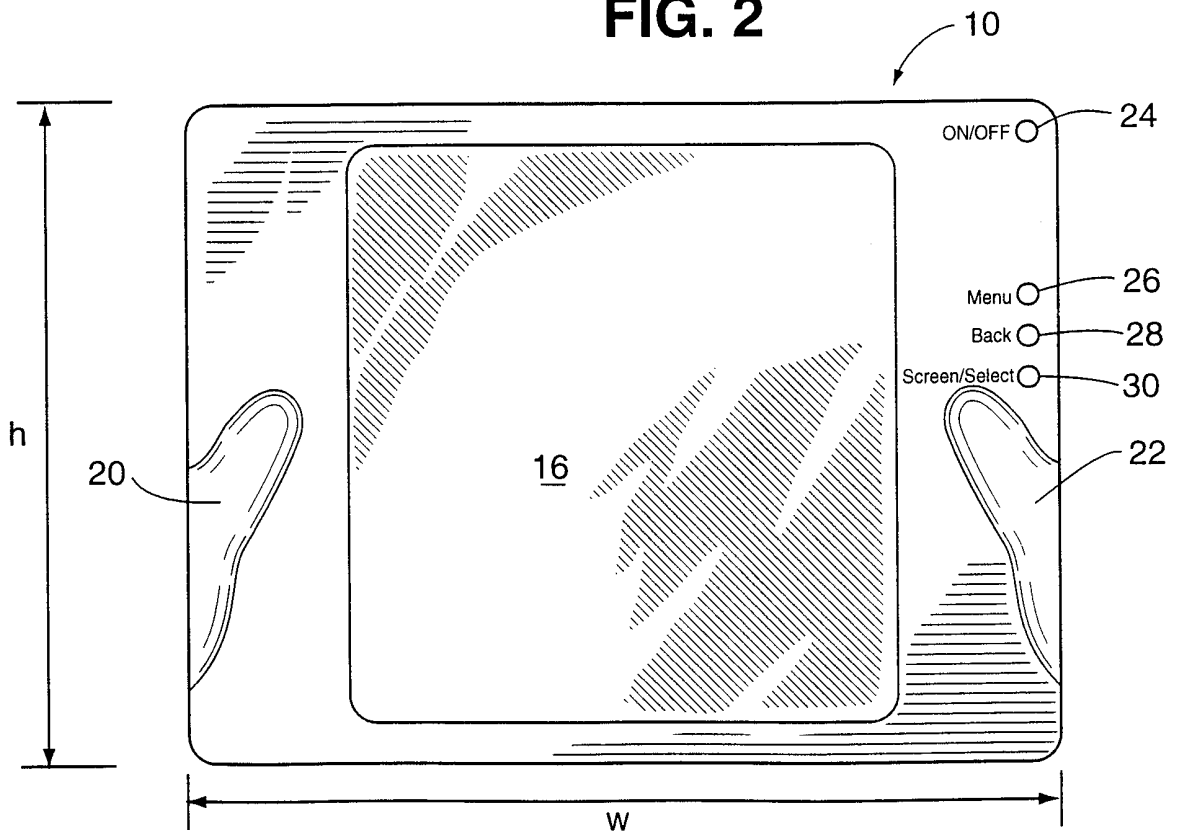

FIG. 2



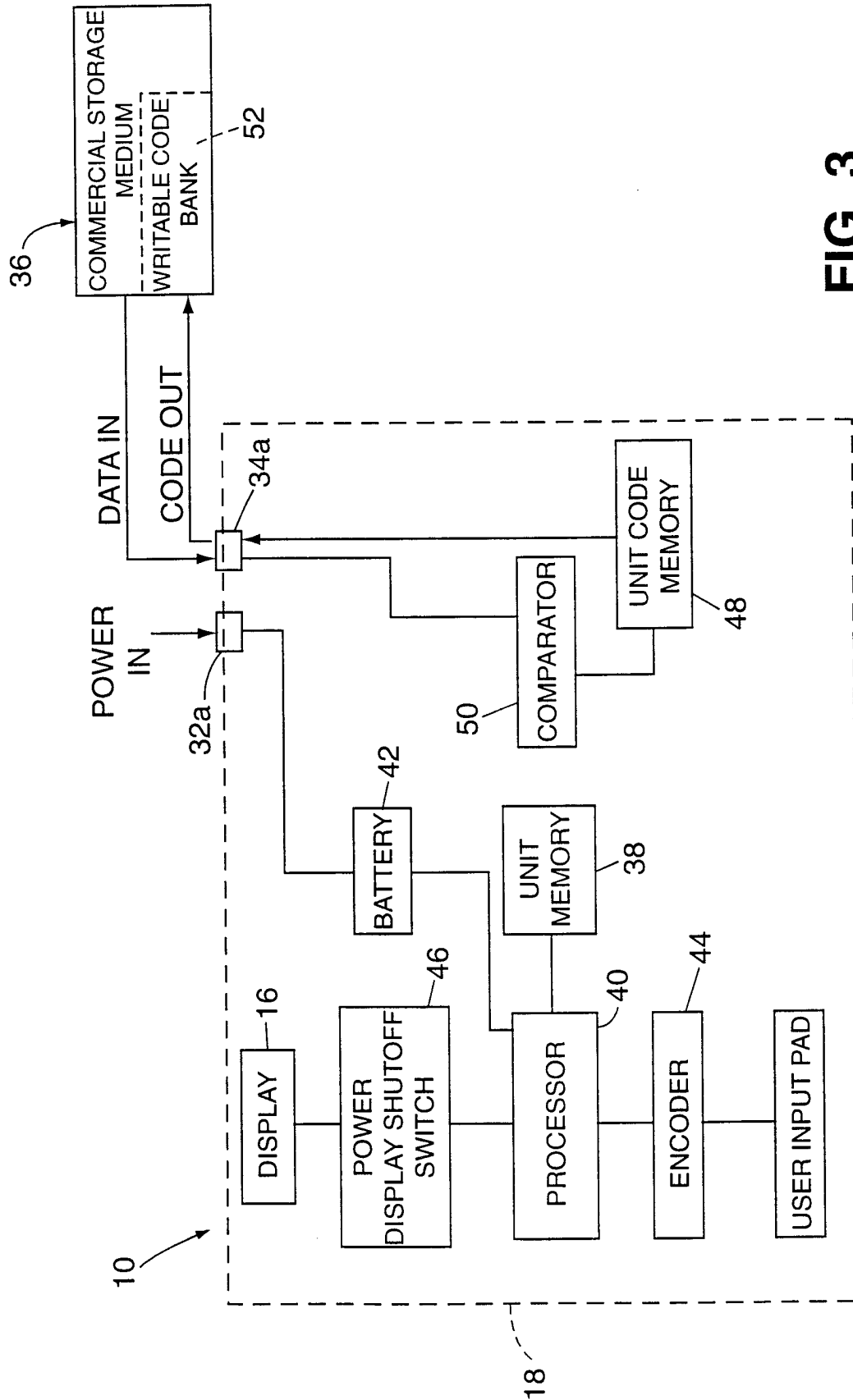

FIG. 3

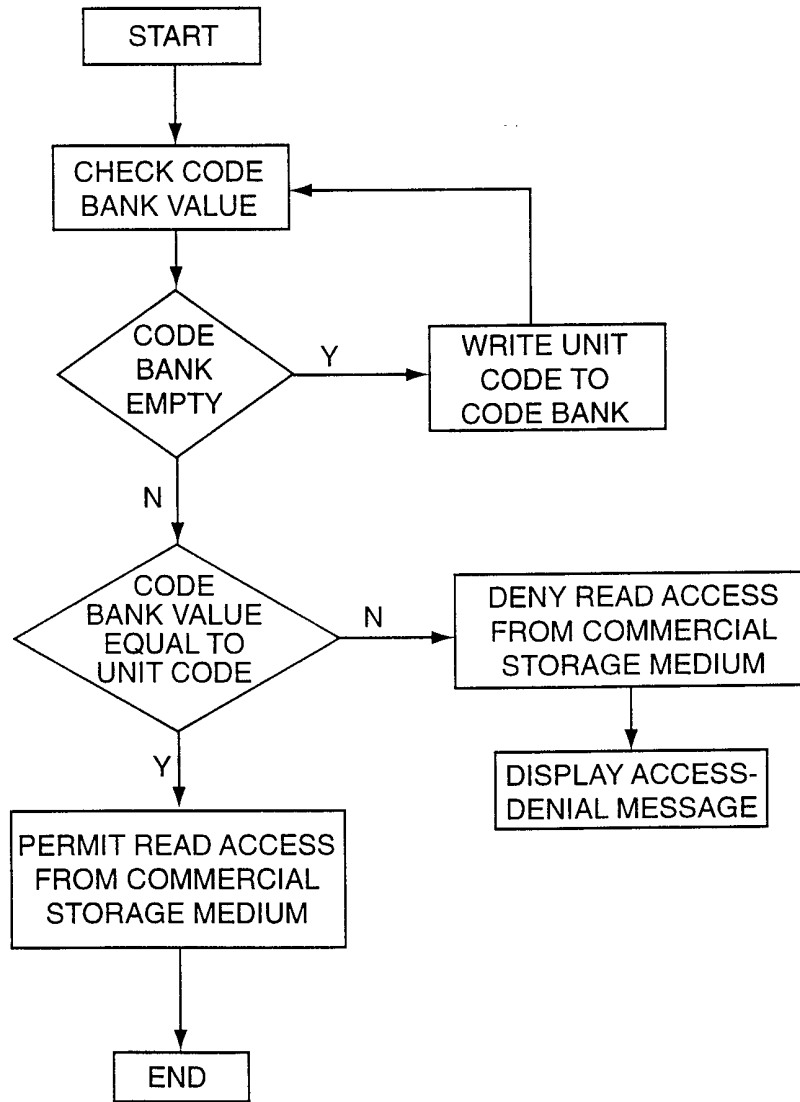

FIG. 4

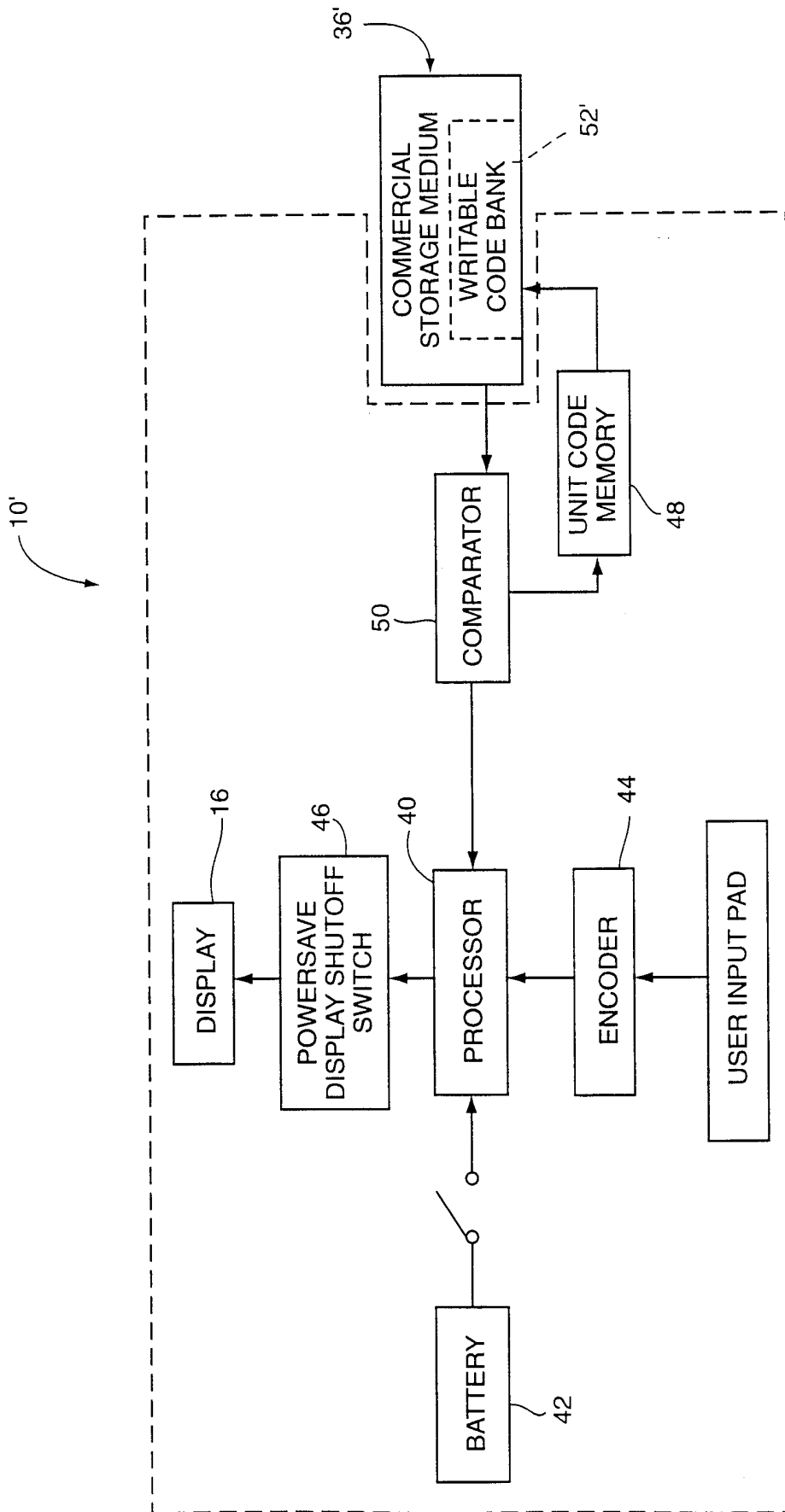

FIG. 5

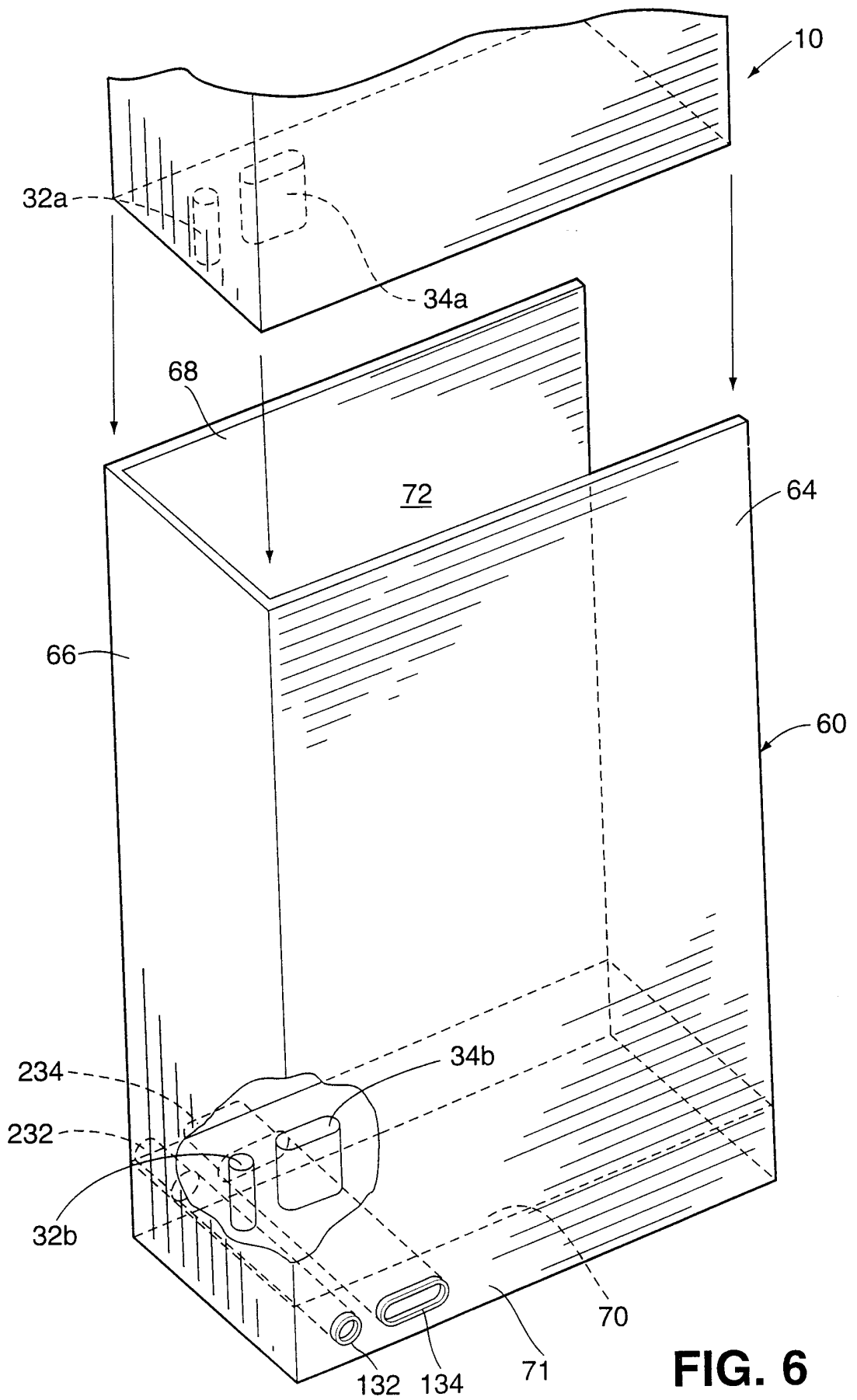
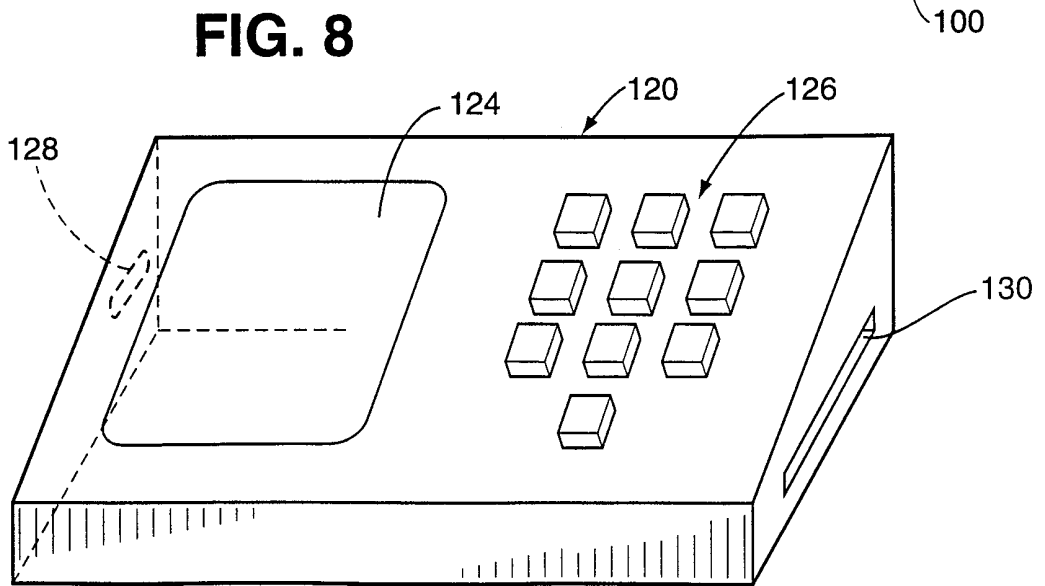
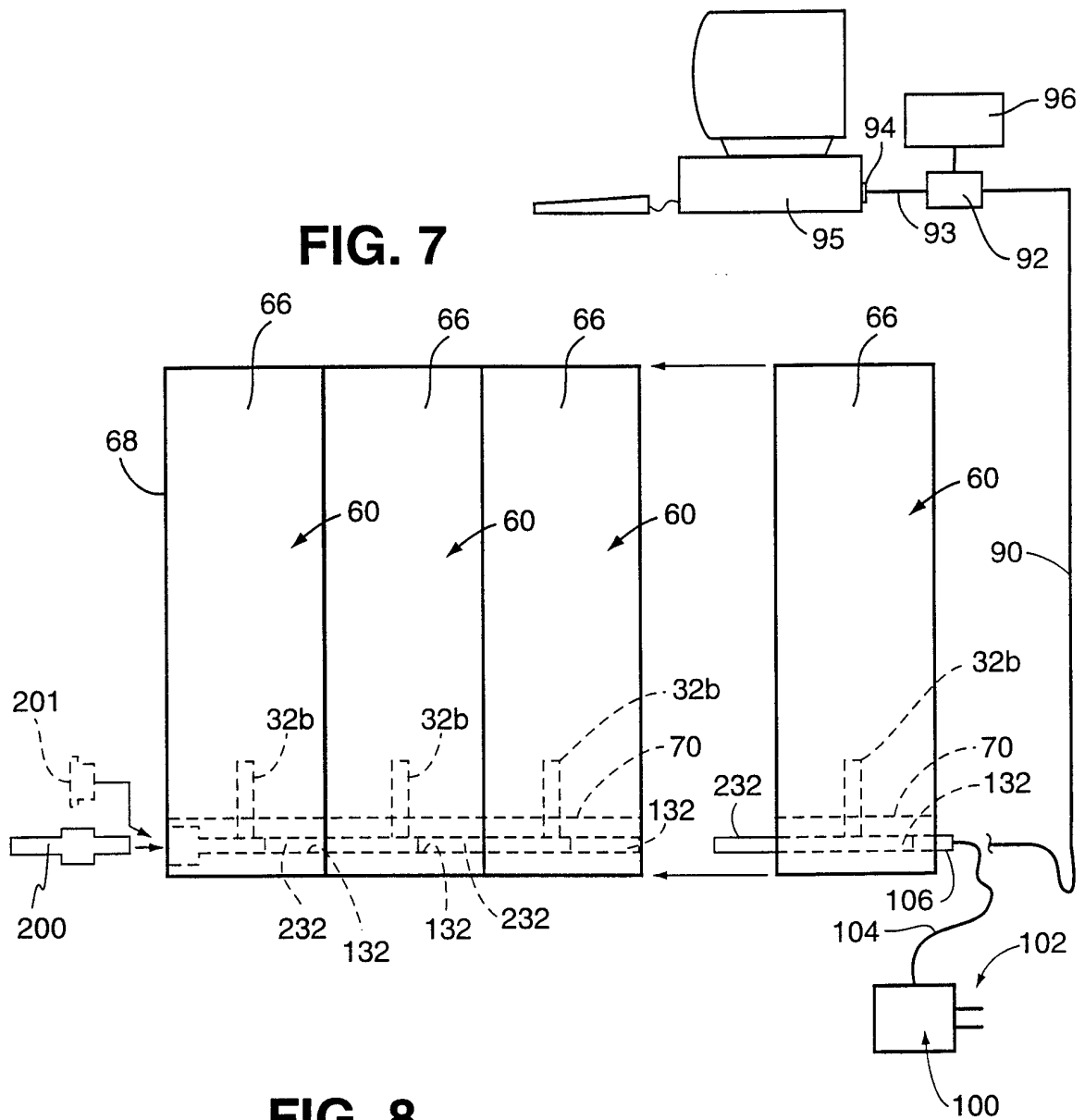

FIG. 6



INTERNATIONAL SEARCH REPORT

International application No.
PCT/US98/24361

A. CLASSIFICATION OF SUBJECT MATTER
 IPC(6) : H01G 4/38; G06F 12/00, 13/00.
 US CL : 345/901,517; 361/330-334; 395/842,849,853,854.
 According to International Patent Classification (IPC) or to both national classification and IPC

B. FIELDS SEARCHED
 Minimum documentation searched (classification system followed by classification symbols)
 U.S. : 345/901,517; 361/330-334; 395/842,849,853,854.

Documentation searched other than minimum documentation to the extent that such documents are included in the fields searched
 none

Electronic data base consulted during the international search (name of data base and, where practicable, search terms used)
 none

C. DOCUMENTS CONSIDERED TO BE RELEVANT

Category*	Citation of document, with indication, where appropriate, of the relevant passages	Relevant to claim No.
X	US, 5,467,102 A (KUNO et al) 14 November 1995, see, figs. 1-3, 11.	1-12,14-18
X	US 5,661,635 A (HUFFMAN et al) 26 August 1997, see, fig.36.	1-12,14-18
---		-----
Y		1-11
X	US 5,325,262 A (MA) 28 June 1994, see, fig.1 (24-26, 14).	1-12,14-18
---		-----
Y		1-11
X	US 5,151,997 A (BAILEY et al) 29 September 1992, see, Abstract,col.2, lines 60- col.3, lines 10.	1-12,14-18
---		-----
Y		12,14-18

Further documents are listed in the continuation of Box C. See patent family annex.

* Special categories of cited documents:	*T* later document published after the international filing date or priority date and not in conflict with the application but cited to understand the principle or theory underlying the invention
A document defining the general state of the art which is not considered to be of particular relevance	*X* document of particular relevance; the claimed invention cannot be considered novel or cannot be considered to involve an inventive step when the document is taken alone
E earlier document published on or after the international filing date	*Y* document of particular relevance; the claimed invention cannot be considered to involve an inventive step when the document is combined with one or more other such documents, such combination being obvious to a person skilled in the art
L document which may throw doubts on priority claim(s) or which is cited to establish the publication date of another citation or other special reason (as specified)	*G* document member of the same patent family
O document referring to an oral disclosure, use, exhibition or other means	
P document published prior to the international filing date but later than the priority date claimed	

Date of the actual completion of the international search 31 JANUARY 1999	Date of mailing of the international search report 31 MAR 1999
--	--

Name and mailing address of the ISA/US Commissioner of Patents and Trademarks Box PCT Washington, D.C. 20231 Facsimile No. (703) 305-3230	Authorized officer AMARE MENGISTU <i>James R. Matthews</i> Telephone No. (703) 308-4880
---	---