



(86) Date de dépôt PCT/PCT Filing Date: 2006/05/17
 (87) Date publication PCT/PCT Publication Date: 2006/11/23
 (45) Date de délivrance/Issue Date: 2014/03/18
 (85) Entrée phase nationale/National Entry: 2007/11/16
 (86) N° demande PCT/PCT Application No.: KR 2006/001834
 (87) N° publication PCT/PCT Publication No.: 2006/123888
 (30) Priorités/Priorities: 2005/05/18 (US60/681,971);
 2005/09/26 (KR10-2005-0089482);
 2006/01/19 (US60/759,963);
 2006/03/09 (KR10-2006-0022150)

(51) Cl.Int./Int.Cl. *G08G 1/0968* (2006.01),
G08G 1/0969 (2006.01)
 (72) Inventeurs/Inventors:
 LEE, JOON HWI, KR;
 SEO, CHU HYUN, KR;
 KIM, YOUNG IN, KR;
 JUNG, MUN HO, KR;
 JOE, MOON JEUNG, KR;
 YI, DONG HOON, KR
 (73) Propriétaire/Owner:
 LG ELECTRONICS INC., KR
 (74) Agent: SMART & BIGGAR

(54) Titre : FOURNITURE D'INFORMATIONS DE TRAFIC COMPRENANT LA PREDICTION DU TEMPS DE
 DEPLACEMENT POUR TRAVERSER UNE LIAISON ET LEUR UTILISATION
 (54) Title: PROVIDING TRAFFIC INFORMATION INCLUDING A PREDICTION OF TRAVEL TIME TO TRAVERSE A
 LINK AND USING THE SAME

<prediction_status_component(01)>:=: predicted travel time for a link
<intunti>(id), : identifier, id=01
<intunti>(n), : length of component data in byte (n)
<intunti>; : time (second)
<intunlo>; : predicted time (UTC)

(57) **Abrégé/Abstract:**

A method for identifying traffic information includes receiving traffic data including a first identifier, information corresponding to a predicted amount of time to traverse a particular link, and information corresponding to a location associated with the particular link, where the first identifier enables a determination of a type of the information that is included within the received traffic data. The method also includes determining a type of information included within the received traffic data based on the first identifier and determining travel time prediction information based on the predicted amount of time included in the received traffic data only if the first identifier enables a determination that the received traffic data includes a prediction related to an amount of time. The method further includes determining location information based on the information that is included in the received traffic data corresponding to the location associated with the particular link and identifying traffic information based on the determined travel time prediction information and the determined location information.



(12) INTERNATIONAL APPLICATION PUBLISHED UNDER THE PATENT COOPERATION TREATY (PCT)

(19) World Intellectual Property Organization
International Bureau(43) International Publication Date
23 November 2006 (23.11.2006)

PCT

(10) International Publication Number
WO 2006/123888 A1

(51) International Patent Classification:

G08G 1/0968 (2006.01) G08G 1/0969 (2006.01)

(21) International Application Number:

PCT/KR2006/001834

(22) International Filing Date: 17 May 2006 (17.05.2006)

(25) Filing Language: English

(26) Publication Language: English

(30) Priority Data:

60/681,971	18 May 2005 (18.05.2005)	US
10-2005-0089482		
	26 September 2005 (26.09.2005)	KR
60/759,963	19 January 2006 (19.01.2006)	US
10-2006-0022150	9 March 2006 (09.03.2006)	KR

(71) Applicant (for all designated States except US): **LG ELECTRONICS INC.** [KR/KR]; 20, Yoido-dong, Youngdungpo-gu, Seoul 150-010 (KR).

(72) Inventors; and

(75) Inventors/Applicants (for US only): **LEE, Joon Hwi** [KR/KR]; 101-2108 Samho Apt., Yangpungdong-3-ga, Youngdungpo-gu, Seoul 150-788 (KR). **SEO, Chu Hyun** [KR/KR]; 205-1706 Jugong 2-cha Apt., Sillim 10(sip)-dong, 201-206 Gwanak-gu, Seoul 151-794 (KR). **KIM, Young In** [KR/KR]; 101-102 Brown-Stone Gwanak Apt., 1721, Bongcheon 2-dong, Gwanak-gu, Seoul 151-052 (KR). **JUNG, Mun Ho** [KR/KR]; 615-701 Jeongdeunmaeul Woosung 6-danji Apt., Jeongja-dong, Bundang-gu, Seongnam-si, Gyeonggi-do 463-753 (KR).**JOE, Moon Jeung** [KR/KR]; 903-1402 Mokryeon Shindongah Apt., Beomgye-dong, Dongan-gu, Anyang-si, Gyeonggi-do 431-776 (KR). **YI, Dong Hoon** [KR/KR]; 102-104 Samsung Raemian Apt., Gireum 1-dong, Seongbuk-gu, Seoul 136-770 (KR).(74) Agent: **PARK, Lae Bong**; 2Fl., Dongun Bldg., 413-4 Dogok 2-dong, Gangnam-gu, Seoul 135-272 (KR).

(81) Designated States (unless otherwise indicated, for every kind of national protection available): AE, AG, AL, AM, AT, AU, AZ, BA, BB, BG, BR, BW, BY, BZ, CA, CH, CN, CO, CR, CU, CZ, DE, DK, DM, DZ, EC, EE, EG, ES, FI, GB, GD, GE, GH, GM, HR, HU, ID, IL, IN, IS, JP, KE, KG, KM, KN, KP, KR, KZ, LC, LK, LR, LS, LT, LU, LV, LY, MA, MD, MG, MK, MN, MW, MX, MZ, NA, NG, NI, NO, NZ, OM, PG, PH, PL, PT, RO, RU, SC, SD, SE, SG, SK, SL, SM, SY, TJ, TM, TN, TR, TT, TZ, UA, UG, US, UZ, VC, VN, YU, ZA, ZM, ZW.

(84) Designated States (unless otherwise indicated, for every kind of regional protection available): ARIPO (BW, GH, GM, KE, LS, MW, MZ, NA, SD, SL, SZ, TZ, UG, ZM, ZW), Eurasian (AM, AZ, BY, KG, KZ, MD, RU, TJ, TM), European (AT, BE, BG, CH, CY, CZ, DE, DK, EE, ES, FI, FR, GB, GR, HU, IE, IS, IT, LT, LU, LV, MC, NL, PL, PT, RO, SE, SI, SK, TR), OAPI (BF, BJ, CF, CG, CI, CM, GA, GN, GQ, GW, ML, MR, NE, SN, TD, TG).

Published:

— with international search report

For two-letter codes and other abbreviations, refer to the "Guidance Notes on Codes and Abbreviations" appearing at the beginning of each regular issue of the PCT Gazette.

(54) Title: PROVIDING TRAFFIC INFORMATION INCLUDING A PREDICTION OF TRAVEL TIME TO TRAVERSE A LINK AND USING THE SAME

<prediction_status_component(01)>:=:	predicted travel time for a link
<intunti>(id),	: identifier, id=01
<intunti>(n),	: length of component data in byte (n)
<intunti>;	: time (second)
<intunlo>;	: predicted time (UTC)

(57) Abstract: A method for identifying traffic information includes receiving traffic data including a first identifier, information corresponding to a predicted amount of time to traverse a particular link, and information corresponding to a location associated with the particular link, where the first identifier enables a determination of a type of the information that is included within the received traffic data. The method also includes determining a type of information included within the received traffic data based on the first identifier and determining travel time prediction information based on the predicted amount of time included in the received traffic data only if the first identifier enables a determination that the received traffic data includes a prediction related to an amount of time. The method further includes determining location information based on the information that is included in the received traffic data corresponding to the location associated with the particular link and identifying traffic information based on the determined travel time prediction information and the determined location information.

WO 2006/123888 A1

DESCRIPTION

PROVIDING TRAFFIC INFORMATION INCLUDING A PREDICTION OF TRAVEL TIME TO TRAVERSE A LINK AND USING THE SAME

1. TECHNICAL FIELD

5 This disclosure relates to providing traffic information including a prediction of travel time to traverse a link, and using the provided traffic information.

2. BACKGROUND ART

10 With the advancement in digital signal processing and communication technologies, radio and TV broadcasts are being digitalized. Digital broadcasting enables provision of various information (e.g., news, stock prices, weather, traffic information, etc) as well as audio and video content.

3. DISCLOSURE OF INVENTION

15 In one general aspect, a method for identifying traffic information is provided. The method includes receiving traffic data including a first identifier, information corresponding to a predicted amount of time to traverse a particular link, and information corresponding to a location associated with
20 the particular link. The first identifier enables a determination of a type of the information that is included within the received traffic data. The method also includes determining a type of information included within the received traffic data based on the first identifier and determining
25 travel time prediction information based on the predicted amount of time included in the received traffic data only if the first identifier enables a determination that the received traffic data includes a prediction related to an amount of time. The method further includes determining location

information based on the information that is included in the received traffic data corresponding to the location associated with the particular link and identifying traffic information based on the determined travel time prediction information and
5 the determined location information.

Implementations may include one or more additional features. For instance, determining travel time prediction information may include accessing received data reflecting, among other items, results of measurements made with respect
10 to traffic previously traversing the link, and computing a prediction for future travel based on the received data. Determining travel time prediction information may involve accessing information provided within the received traffic data and recognizing that data as the predicted travel time.

15 The method may include receiving information corresponding to a message management structure including information corresponding to a generation time of information reflected in the traffic data. The generation time included within the received message management structure may relate to
20 a plurality of message component structures that correspond to more than one of a predicted or current traffic tendency, a predicted or current amount of traffic, a predicted or current speed, or a predicted or current time to traverse a particular link. Each message component structure may further include an
25 identifier specific to the type of information and the first identifier may be an identifier, in a message component structure, specific to the predicted amount of time to traverse the particular link. Information corresponding to a chronological indication associated with the predicted amount
30 of time revealed by the received information may be received. The chronological indication may reflect a particular time of day for which the predicted amount of time corresponds. The chronological indication may be reflected using the universal

time co-ordinated standard.

The travel time prediction information and the location information may be determined in a single step. The location information may be determined before the travel time
5 prediction information is determined. Receiving traffic data may include decoding the traffic data such that the received traffic data is decoded traffic data. The information corresponding to a predicted amount of time to traverse a particular link may reflect the predicted amount of time.

10 In another general aspect, an apparatus for identifying traffic information is provided. The apparatus includes an interface configured to receive traffic data including a first identifier, information corresponding to a predicted amount of time to traverse a particular link, and information
15 corresponding to a location associated with the particular link. The first identifier enables a determination of a type of the information that is included within the received traffic data. The apparatus also includes a processor configured to determine a type of information included
20 within the received traffic data based on the first identifier and dependent upon whether the first identifier enables a determination that the received traffic data includes a prediction related to an amount of time, determining travel time prediction information based on the predicted amount of
25 time included in the received traffic data. The processor is further configured to determine location information based on the information that is included in the received traffic data corresponding to the location corresponding to the particular link and identify traffic information based on the determined
30 travel time prediction information and the determined location information.

Implementations may include one or more additional features. For instance, the processor may be configured to

receive traffic data including information corresponding to a version number of information reflected in the traffic data. The version number is associated with a specific syntax of the data where any one of multiple syntaxes may be used. The processor may also be configured to receive information corresponding to a message management structure including information corresponding to a generation time of information reflected in the traffic data. The processor may be configured to receive information corresponding to a data length of the received data. The processor may be configured to receive the predicted amount of time reflected in seconds. The processor may be further configured to determine the predicted travel time to traverse a particular link only if the first identifier reveals that the traffic data relates to a predicted amount of time to traverse the particular link.

In yet another general aspect, a traffic information communication device is provided. The device includes a data receiving interface and a processor configured to process information received from the data receiving interface and to determine travel time prediction information based at least in part on the information received. The received information includes a message management container that identifies a number of included message component structures and a generation time associated with the message component structures, and more than one message component structure. The message component structures includes a component identifier that identifies information corresponding to a predicted or current traffic tendency, a predicted or current amount of traffic, a predicted or current speed, or a predicted or current time to traverse a particular link, and a value associated with the component identifier that corresponds to the predicted or current traffic tendency, the predicted or current amount of traffic, the predicted or current speed, or

the predicted or current time to traverse a particular link.

Implementations may include one or more additional features. For instance, in one implementation, for at least one of the message component structures, the component
5 identifier and the value associated with the component identifier may correspond to a predicted or current traffic tendency. For at least one of the message component structures, the component identifier and the value associated with the
10 component identifier may correspond to a predicted or current amount of traffic. For at least one of the message component structures, the component identifier and the value associated with the component identifier may correspond to a predicted or
current speed. For at least one of the message component
15 structures, the component identifier and the value associated with the component identifier may correspond to a predicted or current time to traverse a particular link.

In one implementation of the device, at least one of the message component structures, the component identifier and the value associated with the component identifier correspond to a
20 predicted or current traffic tendency, at least one of the message component structures, the component identifier and the value associated with the component identifier correspond to a predicted or current amount of traffic, for at least one of
the message component structures, the component identifier and
25 the value associated with the component identifier correspond to a predicted or current speed, and for at least one of the message component structures, the component identifier and the value associated with the component identifier correspond to a
predicted or current time to traverse a particular link.

30 The processor may be configured to receive traffic data including information corresponding to a version number of information reflected in the traffic data. The version number is associated with a specific syntax of the data where any one

of multiple syntaxes may be used. The processor may be configured to receive information corresponding to a data length of the received data.

5 In accordance with one aspect of the invention there is provided a method for processing traffic information. The method involves receiving the traffic information in a message structure including a number identifier corresponding to the number of traffic information structures in the message structure. The message structure also includes one or several
10 traffic information structures, wherein a first traffic information structure among the traffic information structures has a predicted travel time for a particular road and a first identifier for enabling a determination that the predicted travel time for the particular road is included in the first
15 traffic information structure. The message structure also includes a location information structure having location information associated with the particular road, the location information including coordinates of a start position and an end position of the road. The method also involves decoding
20 the received traffic information in the message structure, and displaying the decoded traffic information.

The predicted travel time and the location information may be determined in a single step.

25 The location information may be determined before the predicted travel time is determined.

The method may involve a second traffic information structure, the second traffic information structure among the traffic information structures including a prediction of average speed for the particular road.

30 In accordance with another aspect of the invention there is provided a method for processing traffic information. The method involves receiving the traffic information in a message

structure including one or several traffic information structures, wherein a first traffic information structure among the traffic information structure has a predicted average speed information for a particular road and a first identifier for enabling a determination that the predicted average speed for the particular road is included in the first traffic information structure. The message structure also includes a location information structure having location information associated with the particular road, the location information including coordinates of a start position and an end position of the road. The message structure further includes a message management structure including information corresponding to a generation time of information reflected in the traffic information. The method also involves decoding the received traffic information in the message structure, and displaying the decoded traffic information. Decoding the received traffic information includes determining the predicted average speed information included in the first traffic information structure based on the first identifier, and determining a location of the particular road based on the location information. The information corresponding to the generation time of information relates to a plurality of components of traffic information that correspond to more than one of a predicted or current traffic tendency, a predicted or current amount of traffic, a predicted or current speed, or a predicted or current time to traverse a particular road.

Each component may be associated with an identifier specific to the type of information.

An additional information structure may include language code information which may be indicative of language used for additional information included in the traffic information.

The message management structure may further include a version number of the traffic information.

5 A second traffic information structure among the traffic information structures may include a prediction of travel time for the particular road, and a second identifier for enabling a determination that the predicted travel time for the particular road may be included in the first traffic information structure.

10 The details of one or more implementations are set forth in the accompanying drawings and the description below. Other features will be apparent from the description and drawings, and from the claims.

15 **4. Brief Description of Drawings**

The accompanying drawings illustrate various implementations.

In the drawings:

FIG. 1 illustrates a schematic diagram of a network through which traffic information is provided;

20 FIG. 2a illustrates a syntax of wirelessly transmitted traffic information;

FIG. 2b illustrates a syntax of TPEG-CTT messages;

FIG. 2c shows syntax of formats of components carrying congestion status information;

25 FIGS. 2d and 2e show syntax of a CTT component carrying CTT events and location information, respectively;

FIG. 2f shows syntax of a CTT component carrying additional information of congestion status information;

30 FIG. 3a illustrates a syntax of the traffic/congestion information included in the CTT event container;

FIGS. 3b through 3e illustrate syntaxes of the average link speed, the link travel time, the link delay, and the congestion type included in the status component shown in FIG. 3a, respectively;

5 FIG. 4a illustrates a syntax of the traffic/congestion prediction information included in the CTT event container;

FIGS. 4b through 4d illustrate syntaxes of the predicted average link speed, the predicted link travel time, and the tendency information included in the status component shown in

10

FIG. 4a, respectively;

FIG. 5a illustrates an example of a database storing the history of traffic status at each link for providing the traffic/congestion prediction information;

5 FIG. 5b illustrates an example of a graphical user interface configured to predict the average speed at a specific link using the database shown in FIG. 5a;

FIG. 6 illustrates a block diagram of a navigation terminal installed in a car for receiving traffic information
10 transmitted from a server in accordance with one implementation;

FIGS. 7a through 7c illustrate examples of graphical user interfaces configured to display the average speed at each link; and

15 FIG. 8 illustrates an example of a graphical user interface configured to display the average speed predicted for a selected link.

5. MODES FOR CARRYING OUT THE INVENTION

One such use for digital broadcasts is to satisfy an
20 existing demand for traffic information. Proposals that involve the use of digital broadcasts for this purpose contemplate the use of standardized formatting of traffic information to be broadcast. This approach may be used to enable the use of traffic information receiving terminals made
25 by different manufacturers, which each could be configured to detect and interpret traffic information broadcast in the same way.

FIG. 1 is a schematic diagram of a network through which traffic information is provided. A traffic information
30 providing server 100 in a broadcast station may transmit traffic information collected from various sources (e.g., operator input, or information received from another server or probe cars through a network 101) wirelessly so that a traffic

information receiving terminal (e.g., navigation system installed in a car 200) may receive the traffic information.

As shown in FIG. 2a, the traffic information wirelessly transmitted from the traffic information providing server 100 may be a sequence of TPEG-CTT (transport protocol expert group-congestion and travel-time Information) messages. A message segment of the sequence, i.e., a TPEG-CTT message, whose syntax is shown in FIG. 2b, may include a message management container 21, a CTT event container (or Application Event Container) 22, and TPEG-CTT location container 23. The TPEG-CTT message may also include different type of containers other than, less than, or in addition to the CTT event container as in the TPEG-CTT message 30.

The message management container 21 may be used for managing date and time information. The time information may include message generation time (e.g., a chronological time indication). The message generation time may be included in every TPEG-CTT message when the corresponding message is transmitted. The CTT event container 22 may include congestion and travel time status and predicted congestion and travel time status of links, i.e., road segments. The congestion and travel time status may include average link speed, link travel time, link delay, or congestion type, etc.

The TPEG-CTT location container 23 may employ various location reference processes. For example, a location reference process using a coordinate system or a location reference process using pre-promised links may be used. When a coordinate system is used, the coordinates (latitudes and longitudes) of the start and end positions of a link for which the TPEG-CTT message is created, may be transmitted. When a reference process using pre-promised links is used, a unique identification for a specific link on a receiving device may be transmitted. For example, a receiving device may include a

locally stored network of links, wherein each link may be identified by a unique identifier. A link may refer to a road segment which starts and ends at junctions and has no junction in between. The coordinate system may be the WGS 84 model. A
5 text formatted name of the link may be transmitted.

In various implementations, a CTT event container and a TPEG-CTT location container, as illustrated in FIG. 2c, are composed of one or more CTT components 201. Each of CTT components may be constructed according to the syntax shown in
10 FIG. 2d if it carries congestion status information while it may be constructed according to the syntax shown in FIG. 2e if the component carries location information.

A CTT event container 22 may be composed of one component or a plurality of CTT components. In various implementations,
15 CTT components including an ID of 80h (notation 'h' means hexadecimal) or 84h includes one or more status components including basic traffic information such as the average link speed, link travel time, link delay, or congestion type. In the description, specific IDs are described as assignments to
20 structures associated with specific information. The actual value of an assigned ID (e.g., 80h) is exemplary, and different implementations may assign different values for specific associations or circumstances.

In various implementations, CTT components including an
25 ID of 81h include one or more status components including predicted CTT status. The predicted CTT status may include predicted average link speed, predicted link travel time, or congestion acceleration tendency. The congestion acceleration tendency may include information indicative of the tendency of
30 congestion status. The congestion acceleration tendency will be described as a type of prediction information as the congestion status in the near future may be predicted from it.

In various implementations, the TPEG-CTT message may

comprise CTT components structured as FIG. 2f to deliver additional information of traffic information. As shown, an identifier 8Ah may be assigned to the CTT component carrying additional information, and a language code that is indicative of language used for the additional information may also be included in the CTT component.

FIG. 3a shows an example of a syntax of the CTT component included in the CTT event container, which delivers the current congestion and travel time status. The CTT component may be assigned an ID 3a including a value of 80h or 84h and may include m status components 3c and a field 3b indicative of the length of the data included in the status components included therein, the length being expressed in the unit of byte. Other units, such as bit, may be used.

The status components 3c may include information on the average link speed, the link travel time, the link delay, and/or the congestion type. The syntax, according to one implementation, of each of which, is shown in FIGS. 3b, 3c, 3d, and 3e, respectively. In one implementation, status components delivering the average link speed, the link travel time, the link delay, and the congestion type are assigned IDs of '00', '01', '02', and '03', respectively. The link delay may be, for example, the delay in the time required to pass through the link under current traffic condition with respect to the time required to pass through the link at a limit speed specified in the link. The link delay may be expressed in the unit of minute, second, tens or tenths of seconds, or another unit. The link delay may be calculated with respect to the average time required to pass the link on the same days or in the same time slot. The link delay may enable traffic information receiving terminals that do not have information on each link (e.g., speed limit in the link, length of the link, etc) to expect the time required to pass a link.

FIG. 4a shows an example of a syntax of the CTT component included in the CTT event container, which delivers the predicted congestion and travel time status. The CTT component may be assigned an ID 4a including a value of 81h and may
5 include m status components 4c and a field 4b indicative of the length of the data included in the status components included therein, the length, may be, for example, expressed in the unit of byte.

The status components 4c may include information on the
10 predicted average link speed, the predicted link travel time, and/or, the congestion acceleration tendency, the syntax, according to one implementation, of each of which, is shown in FIGS. 4b, 4c, and 4d, respectively. The status components delivering the predicted average link speed, the predicted
15 link travel time, and the congestion acceleration tendency may be assigned IDs of '00', '01', and '02', respectively.

Alternatively, the predicted congestion and travel time status may be delivered by the CTT component that delivers the current congestion and travel time status (e.g., average link
20 speed, link travel time, link delay, congestion type) including an ID of 80h or 84h. In this case, the status components delivering the predicted congestion and travel time status may be assigned IDs different from the IDs of the status components delivering the current congestion and travel
25 time status.

The server 100 may create predicted status information shown, according to one implementation, in FIGS. 4b through 4d based on the traffic information which may be collected from various sources and/or its own traffic information database,
30 which will be described in detail below.

To provide predicted traffic information, the server 100 may store the average speed at each link according to day, time slot, week, month, or year. For example, in one

implementation, the server 100 may store the average speed at each link at intervals, such as every 30 minutes, as shown in FIG. 5a. The unit of the values shown in FIG. 5a is km/h, though other units, such as m/s, may be used.

5 Additionally, in one implementation, the server 100 may store the average speed, or other information, such as travel time or congestion, of links for which the traffic information is currently provided at intervals for a predetermined period of time (e.g., 3 hours) and compare the pattern of change in
10 the average speed for the period of time with the pattern of change in the same time slot of the same day stored in the database. For example, if FIG. 5b shows the pattern of change in the average speed for the past 3 hours from 4:30 pm on a Monday afternoon (A), the server 100 compares the data with
15 the average speeds of from 1:30 pm to 4:30 pm stored in the database (B). If the difference (e.g., the sum of the absolute values of the difference in average speeds at each corresponding time or a weighted sum thereof) is less than a predetermined threshold, the server 100 reads the average
20 speed B1 at 30 minutes after the current time (i.e., the average speed at 5:00 pm) from the database and transmits the value as the predicted average speed in the corresponding link according to the syntax shown in FIG. 4b. The predicted average link speed may be expressed in the unit of km/h, for
25 example. The predicted time (e.g., 5:00 pm in the previous example) may also be transmitted in the form of the syntax shown in FIG. 4b, for example in UTC (Universal Time Coordinated) format.

Explaining FIG. 4b in more detail, the predicted time in
30 UTC format may be indicative of a target time or date in the future, and the predicted speed indicates average speed (in km/h, for example) on a link at the target time or date, such as, a day of year, month of year, year, holiday, time of day,

rush hour, event, morning/afternoon/evening. For example, the link may be an inter-road between cities, a bridge, or a road between intersections. The data may be incorporated into the component in units of a byte unit, and/or it may be
5 incorporated in units of a bit or a long byte, according to data size. In addition, the speed may be expressed in various units, for example, m/sec, mile/hour, etc.

In one implementation, if the calculated difference exceeds the predetermined threshold, i.e., it is determined
10 that the pattern of change in the average speed stored in the database does not match the pattern of change in the measured average speed, the server 100 may not provide the predicted average link speed, or alternatively, the server 100 may estimate the predicted average link speed A1 from the average
15 link speeds extracted for the past 3 hours and provide the estimated value as the predicted average link speed. Various processes may be used to estimate the average speed from the measured average speed values. One process, for example, involves calculation of a weighted sum which gives the latest
20 sample value the highest weight and gives the oldest sample value the lowest weight. For example, the predicted speed A1 in FIG. 5b can be extracted by calculating $0.5 \times \text{current speed} + 0.2 \times \text{speed of 30 minutes ago} + 0.1 \times \text{speed of 1 hour ago} + 0.1 \times \text{speed of 1.5 hours ago} + 0.05 \times \text{speed of 2 hours ago} +$
25 $0.05 \times \text{2.5 hours ago, etc.}$

After calculating the predicted average link speed in the aforementioned way, the server 100 may calculate the predicted travel time of each link and transmit the predicted travel time of each link along with associated predicted time
30 according to the syntax shown in FIG. 4c. The predicted travel time may be calculated by multiplying the predicted average speed at each link by the length of the corresponding link stored in the database. The predicted travel time may be

expressed in the unit of minutes, tens of seconds, second, or a unit smaller than seconds, for example.

When providing the average speed in a particular link, the server 100 may compare the current average speed with the
5 average speed at the previous time slot and provide the tendency of change in the average link speeds 41 according to the syntax shown in FIG. 4d. In one implementation, the information, which is called the congestion acceleration tendency, may have one value among several values defined by a
10 table shown in FIG. 4d. For example, the information may be assigned 1 if the current average speed is higher than the average speed of 30 minutes ago. The congestion acceleration tendency may be assigned 2 if the current average speed is lower than the average speed of 30 minutes ago. The congestion
15 acceleration tendency may be assigned 3 if the average speed remains unchanged. If there is no available data to compare, the congestion acceleration tendency may be assigned 0. The congestion acceleration tendency information may enable a driver to choose a route that shows improvement in the traffic
20 congestion from among several possible routes showing similar average speeds. Instead of providing the congestion acceleration tendency in the form of a number (e.g., 1, 2, 3, etc.), the server 100 may provide the rate of change of the average speed, i.e., the slope in the graph shown in FIG. 5b
25 as the congestion acceleration tendency, or other indicia or descriptors.

In one implementation, the server 100 may prevent the size of information which it should transmit from becoming excessively large by maintaining the ratio of the current
30 congestion and travel time status to the predicted congestion and travel time status below an appropriate level (e.g., 3:1).

FIG. 6 is an example of a block diagram of a navigation terminal for receiving traffic information transmitted from

the server 100. Figs. 6-8 are example implementations of systems for receiving and utilizing traffic information, and interfaces used to output information generated by such systems. Other systems may be organized differently or include 5 different components.

As illustrated by Fig. 6, the navigation terminal comprises a tuner 1 for receiving modulated traffic information signals by resonating at the required frequency band, a demodulator 2 for outputting traffic information 10 signals by demodulating the modulated signals from the tuner 1, a TPEG-CTT decoder 3 for extracting traffic information by decoding the demodulated traffic information signals, a GPS module 8 for calculating the current position (i.e., latitude, longitude, and altitude) by receiving signals from a plurality 15 of low-orbit satellites, storage structure 4 for storing various graphic data and an electronic map including information on links and nodes, an input device 9 for receiving user input, a navigation engine 5 for controlling screen display based on the user input, the current position, 20 and extracted traffic information, a memory 5a for storing data temporarily, an LCD panel 7 for displaying data, and an LCD drive 6 for driving the LCD panel 7 according to data to be presented. The input unit 9 may be a touch screen incorporated into the LCD panel 7.

25 The tuner 1 tunes to the frequency of the signals transmitted by the server 100 and the demodulator 2 demodulates the tuned signals in a predetermined manner. The TPEG-CTT decoder 3 decodes the demodulated signals into a TPEG-CTT message sequence as shown in FIG. 2, interprets each 30 TPEG message included in the TPEG-CTT message sequence, and sends necessary information and/or control signals to the navigation engine 5. For purposes of brevity, the following description focuses on basic congestion and travel time status

shown in FIGS. 3b through 3e and predicted congestion and travel time status shown in FIGS. 4b through 4d though other status information is involved, such as, for example, speed, is involved.

5 The TPEG-CTT decoder 3 extracts date/time and message generation time included in the message management container of each TPEG message and determines if the following container is a CTT event container based on 'message element' information (i.e. an identifier). If it is determined that the
10 following container is a CTT event container, the TPEG-CTT decoder 3 provides the navigation engine 5 with the information extracted from the CTT component included in the CTT event container so that the navigation engine 5 may display congestion and travel time status and predicted
15 congestion and travel time status, which will be described below. Providing the navigation engine 5 with the information may include determining, based on identifiers, that the traffic information includes a message management container including status information within various message components
20 within the message management container. The components may each include different status information associated with different links or locations and identifiers associated with the different status information. The containers and components may each include information associated with a
25 generation time, version number, data length, and identifiers of included information.

The TPEG-CTT decoder 3 then extracts information on the link location for which the previously extracted information is intended from the following TPEG-CTT location container.
30 The position information may be, for example, the coordinates (i.e., latitudes and longitudes) of the start and end positions or an ID that is uniquely assigned to each link, depending on the type of the TPEG-CTT location container. If

the navigation terminal is equipped with the storage structure 4, the navigation engine 5 finds the location of the link for which the received traffic information is intended with reference to the information on each link and node stored in the storage structure 4. The navigation engine 5 may convert the coordinates of a link into a link ID or vice versa.

The navigation engine 5 reads a part of the electronic map centered around the position coordinates received from the GPS module 8 from the storage structure 4 and displays the map on the LCD panel 7 via the LCD drive 6. A particular graphic symbol is displayed at the location corresponding to the current position on the LCD panel 7.

The navigation engine 5 displays the average link speed received from the TPEG-CTT decoder 3 at a location corresponding to the coordinates or link ID delivered via the TPEG-CTT location container following the container delivering the average link speed. There are various processes for the navigation engine 5 to display the traffic information. For example, the navigation engine 5 may show links in different colors according to the average speed at the links as shown in FIGS. 7a and 7b, where the colors red, orange, green, and blue (colors themselves not shown) may be used to indicate average speeds of 0~10 km, 10~20 km, 20~40 km, over 40 km, respectively. Alternatively, the navigation engine 5 may show the average link speed in numbers at each link as shown in FIG. 7c, or a combination of colors and numbers may be used. In addition or as an alternative, the navigation engine 5 may use similar display tools to display the congestion acceleration tendency received from the TPEG-CTT decoder 3 at the corresponding link, or through the use of other display tools such as through the use of an icon or a string (e.g., 'improved' if the value of the congestion acceleration tendency is 1 and 'deteriorated' if the value is 2). In this

case, the navigation engine 5 maintains the status unchanged if the value of the congestion acceleration tendency is 0 or 3. If the congestion acceleration tendency is received in the form of the rate of change of the average speed, the navigation engine 5 displays the value only when a request from the user is received to prevent visual confusion of the user. The rate of change may be displayed together for a user-chosen route or a front link.

If the navigation terminal is not equipped with the storage structure 4 for storing an electronic map, the terminal may show the average link speed at links located in front of the current position in different colors, as shown in FIG. 7b, or in numbers, as shown in FIG. 7c. If the route of the vehicle with the navigation terminal installed is determined, the navigation terminal may show the average speed at the links included in the determined route instead of the links located in front of the current position.

The navigation engine 5, responsive to user input, may display the link travel time, the link delay, and the congestion type received from the TPEG-CTT decoder 3 on the LCD panel 7 instead of or simultaneously with the average link speed.

If the user requests predicted congestion and travel time status through the input unit 9, the navigation engine 5 displays the predicted average link speed at each link received from the TPEG-CTT decoder 3 in colors or in numbers instead of the current average link speed. In this case, the colors or numbers describing the predicted status may be displayed simultaneously with the current average link speed but the location or used colors may be different. If the user switches the display mode to see the predicted link travel time instead of the predicted average link speed, the navigation engine 5 displays the predicted link travel time on

the electronic map or graphics on the LCD panel 7.

If the navigation engine 5 is capable of routing, the navigation engine 5 may search or research the desirable route based on the received predicted average link speed or 5 predicted link travel time. For example, the navigation engine 5 finds the shortest time path to the destination by using the predicted link average time or predicted link travel time at each link to be reached 30 minutes later at the current speed.

If the terminal in FIG. 6 is equipped with a voice output 10 capability, the terminal may audibly output the received predicted status or congestion tendency information for a specified link or links.

The information and/or control signals received from the TPEG-CTT decoder 3 are temporarily stored in the rewritable 15 memory 5a and used by the navigation engine 5. After using the information stored in the memory 5a, the navigation engine 5 may store the average link speed or link travel time at intervals of, such as, for example, 20 minutes (e.g., 1:00, 1:20, 1:40) for the last 1 hour. The interval of storage may 20 differ depending on the storage capacity of the memory 5a. By automatically expiring the information from within memory, the system may be assured that it is working with recent information when consulting the contents of the memory, and thus may be able to represent information as current with 25 confidence without having to otherwise maintain or check information reflecting when the stored data was collected/aggregated/stored.

If a specific link is selected by the user while the average speed at each link is stored in the memory 5a, the 30 navigation engine 5 controls the LCD drive 6 so that the history of the average link speed or the history of the link travel time at the specified link is displayed as a graph shown in FIG. 8. In the graph, the unit of the displayed

numbers is km/h and the name 81 of the link is displayed on the graph. The link name is received along with the coordinates of the link or link ID through the TPEG location container 23 or included in the electronic map stored in the storage structure 4. The current congestion status, predicted congestion status, or other status may be displayed in other or different ways.

If the predicted congestion status is not included in the received traffic information, the navigation engine 5 may predict the average speed using the current average speed and the history of the average link speed stored in the memory 5a and display the predicted average link speed, as shown in FIG. 8a. The method for predicting the average link speed may be the same as the aforementioned prediction method executed in the server 100.

While the disclosure has discussed a limited number of implementations, those skilled in the art having the benefit of this disclosure will appreciate numerous modifications and variations therefrom. It is intended that all such modifications and variations fall within the spirit and scope of this disclosure.

THE EMBODIMENTS OF THE INVENTION IN WHICH AN EXCLUSIVE PROPERTY OR PRIVILEGE IS CLAIMED ARE DEFINED AS FOLLOWS:

1. A method for processing traffic information, the method comprising:

receiving the traffic information in a message structure including:

5 a number identifier corresponding to the number of traffic information structures in the message structure;

one or several traffic information structures wherein a first traffic information structure among the traffic information structures has a predicted travel time for a particular road and a first identifier for enabling a determination that the predicted travel time for the particular road is included in the first traffic information structure; and

10

a location information structure having location information associated with the particular road, wherein the location information includes coordinates of a start position and an end position of the road;

15

decoding the received traffic information in the message structure; and

displaying the decoded traffic information.

2. The method of claim 1, wherein the predicted travel time and the location information are determined in a single step.
- 20
3. The method of claim 1, wherein the location information is determined before the predicted travel time is determined.

4. The method of claim 1, further including a second traffic information structure, wherein the second traffic information structure among the traffic information structures comprises a prediction of average speed for the particular road.

5. A method for processing traffic information, the method comprising:

5 receiving the traffic information in a message structure including:

10 one or several traffic information structures wherein a first traffic information structure among the traffic information structure has a predicted average speed information for a particular road and a first identifier for enabling a determination that the predicted average speed for the particular road is included in the first traffic information structure;

15 a location information structure having location information associated with the particular road, wherein the location information includes coordinates of a start position and an end position of the road; and

a message management structure including information corresponding to a generation time of information reflected in the traffic information;

decoding the received traffic information in the message structure; and

20 displaying the decoded traffic information;

wherein decoding the received traffic information includes determining the predicted average speed information included in the first traffic information structure based on the first identifier, and determining a location of the particular road based on the location information.

6. The method of claim 5, wherein the information corresponding to the generation time of information relates to a plurality of components of traffic information that correspond to more than one of a predicted or current traffic tendency, a predicted or current amount of traffic, a predicted or current speed, or a predicted or current time to traverse a particular road.
5
7. The method of claim 6, wherein each component is associated with an identifier specific to the type of information.
8. The method of claim 5, further including an additional information structure including language code information which is indicative of language used for additional information included in the traffic information.
10
9. The method of claim 8, wherein the message management structure further includes a version number of the traffic information.
10. The method of claim 8, further including a second traffic information structure, wherein the second traffic information structure among the traffic information structures includes a prediction of travel time for the particular road, and a second identifier for enabling a determination that the predicted travel time for the particular road is included in the first traffic information structure.
15

FIG. 1

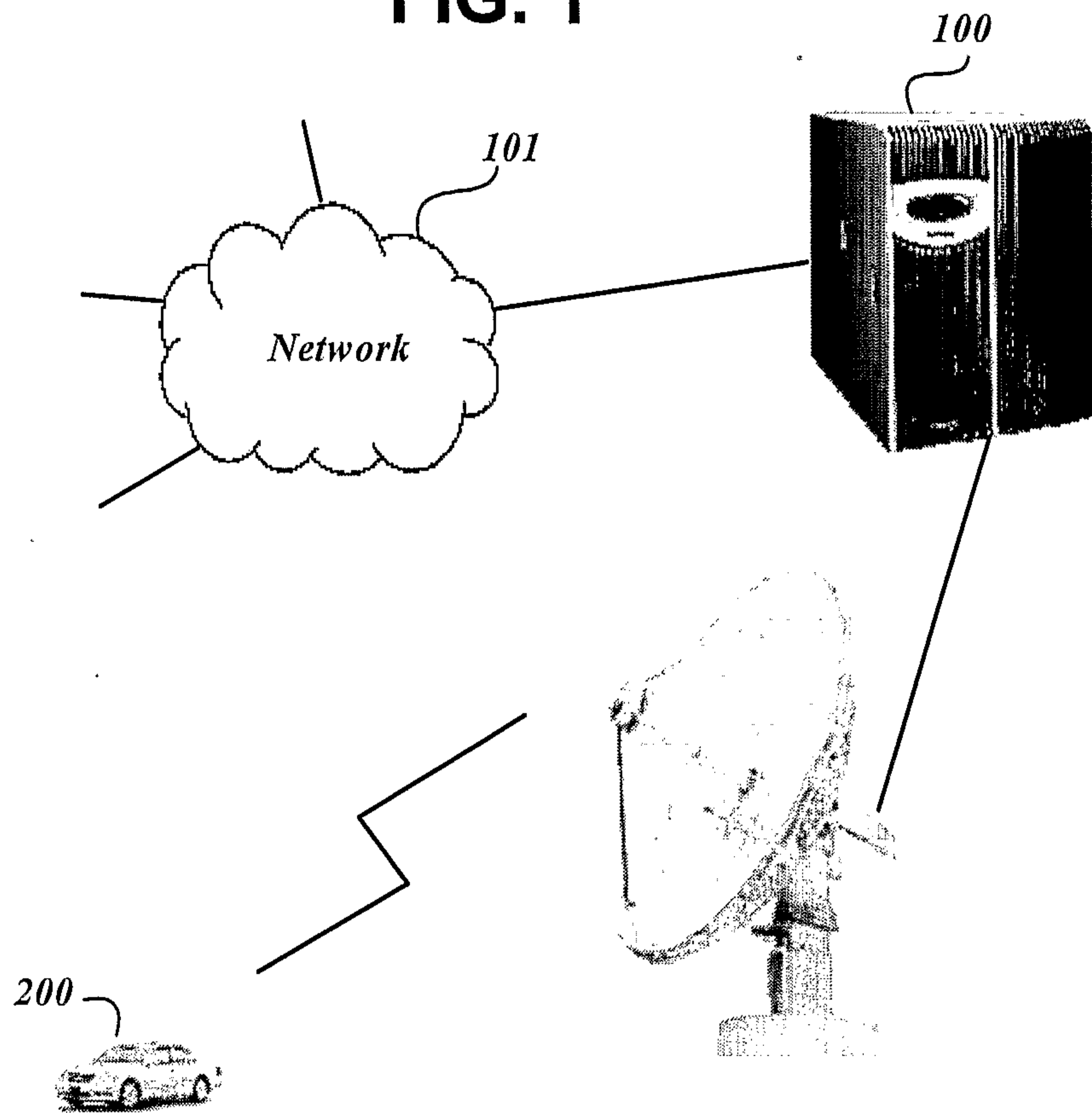
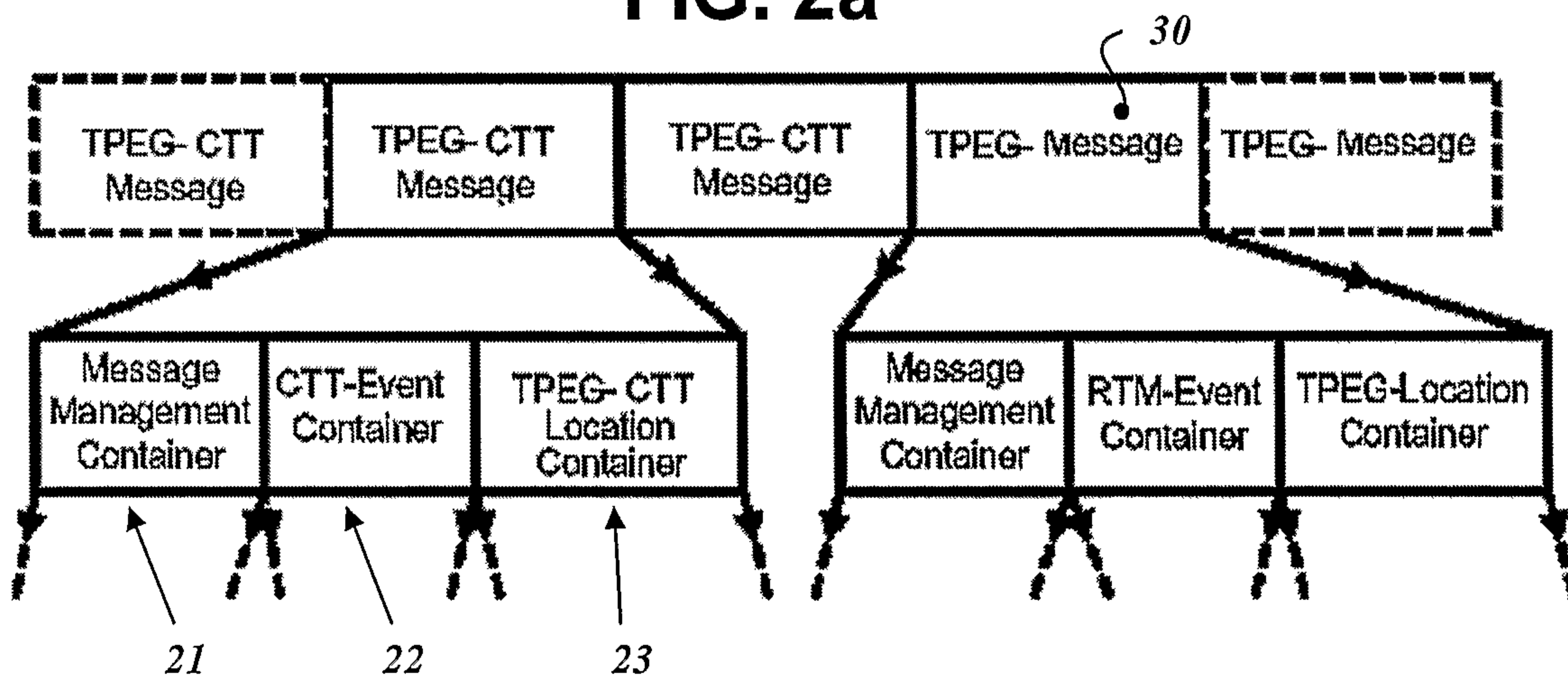

FIG. 2a



2/10

FIG. 2b

<ctt_message> :=	
<intunli>(mid),	: message identifier
<intunti>(ver),	: version number
<intunli>	: message length in expressed in byte
<bitswitch>(selector),	: message element
if(selector=xxxxxx1)<time_t>,	: generation time of message
if(selector=xxxxxx1x)<intunlo>,	: Reserved for future use
if(selector=xxxxx1xx)<intunlo>,	: Reserved for future use
if(selector=xxxx1xxx)<intunlo>,	: Reserved for future use
if(selector=xxx1xxxx)<intunlo>,	: Reserved for future use
if(selector=xx1xxxx)<intunlo>,	: Reserved for future use
if(selector=x1xxxxxx)<intunlo>,	: Reserved for future use
if(selector=1xxxxxxx)<ctt_components>,	: message component of CTT information

FIG. 2c

<ctt_components>:=	
<intunti>(n),	: the number of components
n*<ctt_component()>;	: message component of CTT information

201

FIG. 2d

<ctt_component (x)>:=	: Template of component of CTT message
<intunti>(id),	: identifier
<intunti>(n),	: length of component data in byte (n)
n*<bytes>;	: component data

3/10

FIG. 2e

<ctt_component (x)>:=	: CTT – Loc
<intunti>(id),	: identifier
<intunli>(n),	: length of component data in byte (n)
<tpeg_loc_container>;	: TPEG location container

FIG. 2f

<ctt_component (8A)>:=	: Congestion and Travel Time
<intunti>(id),	: identifier, id=8A
<intunli>(n),	: length of component data in byte (n)
<ctt41>,	: language code
<short_string>;	: Additional information

4/10

FIG. 3a**FIG. 3b****FIG. 3c****FIG. 3d**

FIG. 3e

<status_component(03)>:=	: congestion type
<intunti>(id),	: identifier, id=03
<intunti>(n),	: length of component data in byte (n)
<cti01>;	: congestion type

FIG. 4a

<cti_component (81)>:=	: Prediction of Congestion and Travel Time Status
<intunti>(id),	: identifier, id=81
<intunti>(n),	: length of component data in byte (n)
m*<prediction_status_component()>;	: status component

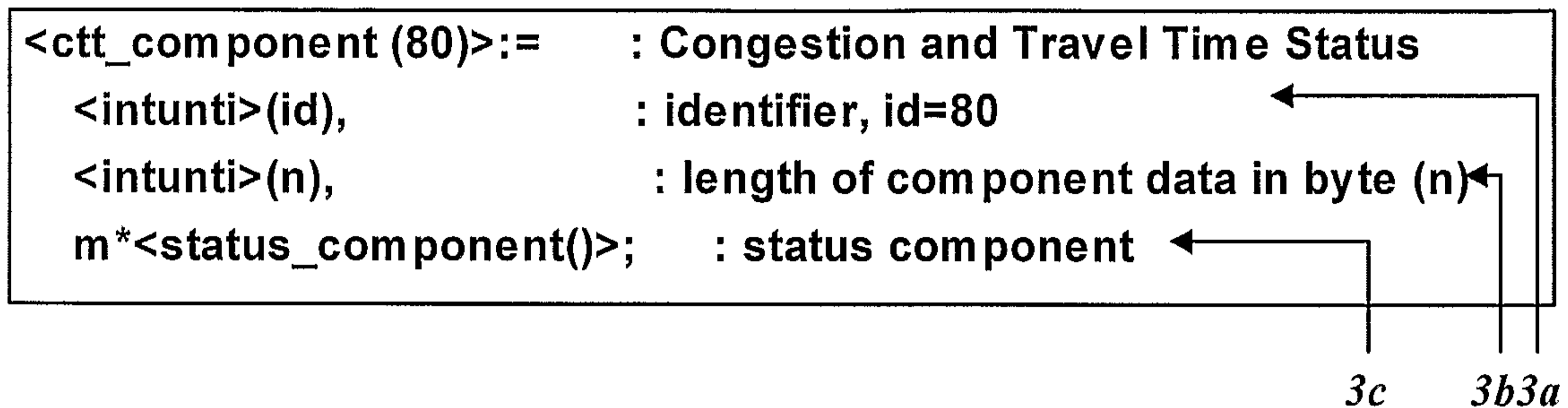
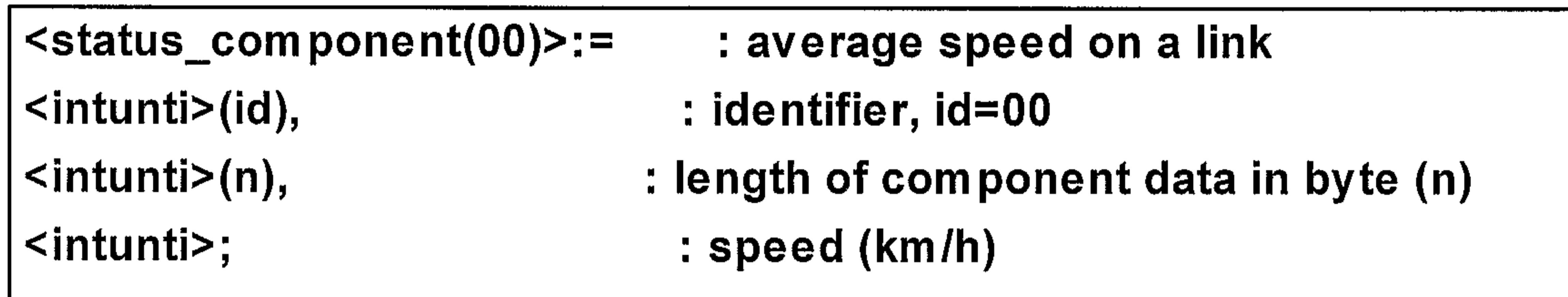
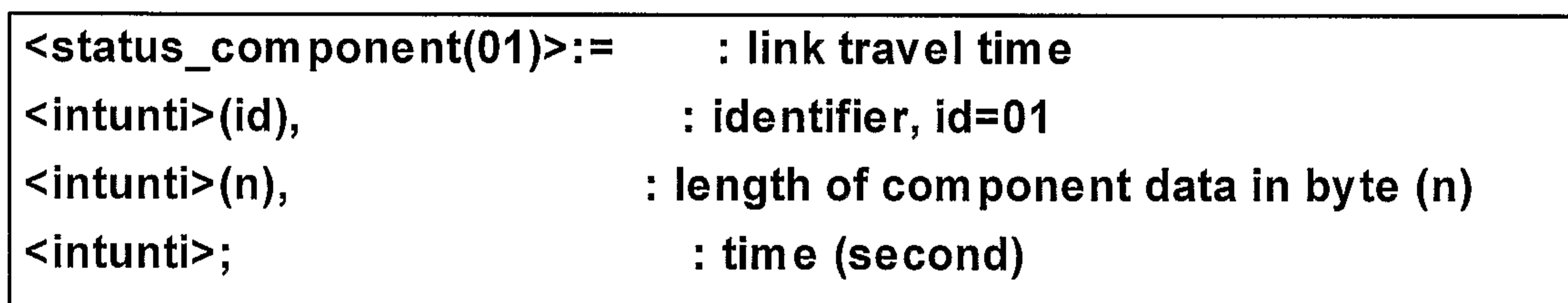
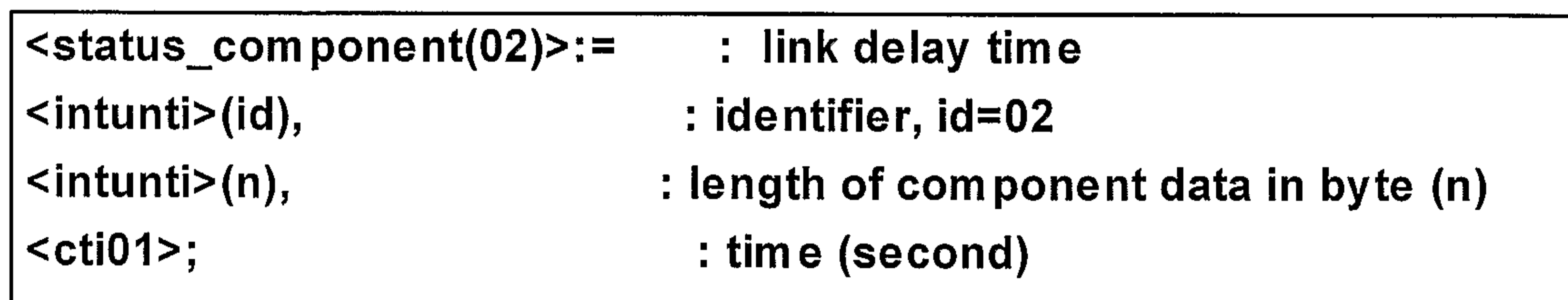
4c 4b 4a

FIG. 4b

<prediction_status_component(00)>:=	predicted average speed for a link
<intunti>(id),	: identifier, id=00
<intunti>(n),	: length of component data in byte (n)
<intunti>;	: speed (km/h)
<intunlo>;	: predicted time (UTC)

FIG. 4c

<prediction_status_component(01)>:=	predicted travel time for a link
<intunti>(id),	: identifier, id=01
<intunti>(n),	: length of component data in byte (n)
<intunti>;	: time (second)
<intunlo>;	: predicted time (UTC)

FIG. 4d

<prediction_status_component(02)>:= congestion type
<intunti>(id), : identifier, id=02
<intunti>(n), : length of component data in byte (n)
<ctt04>; : congestion tendency

41

TPEG Table CTT Information 04(CTT 04) congestion tendency

code	meaning	description	example
0	unknown		
1	drawing		
2	eliminating		
3	constant		
	End of version k		
:	:	:	:
255			

FIG. 5a

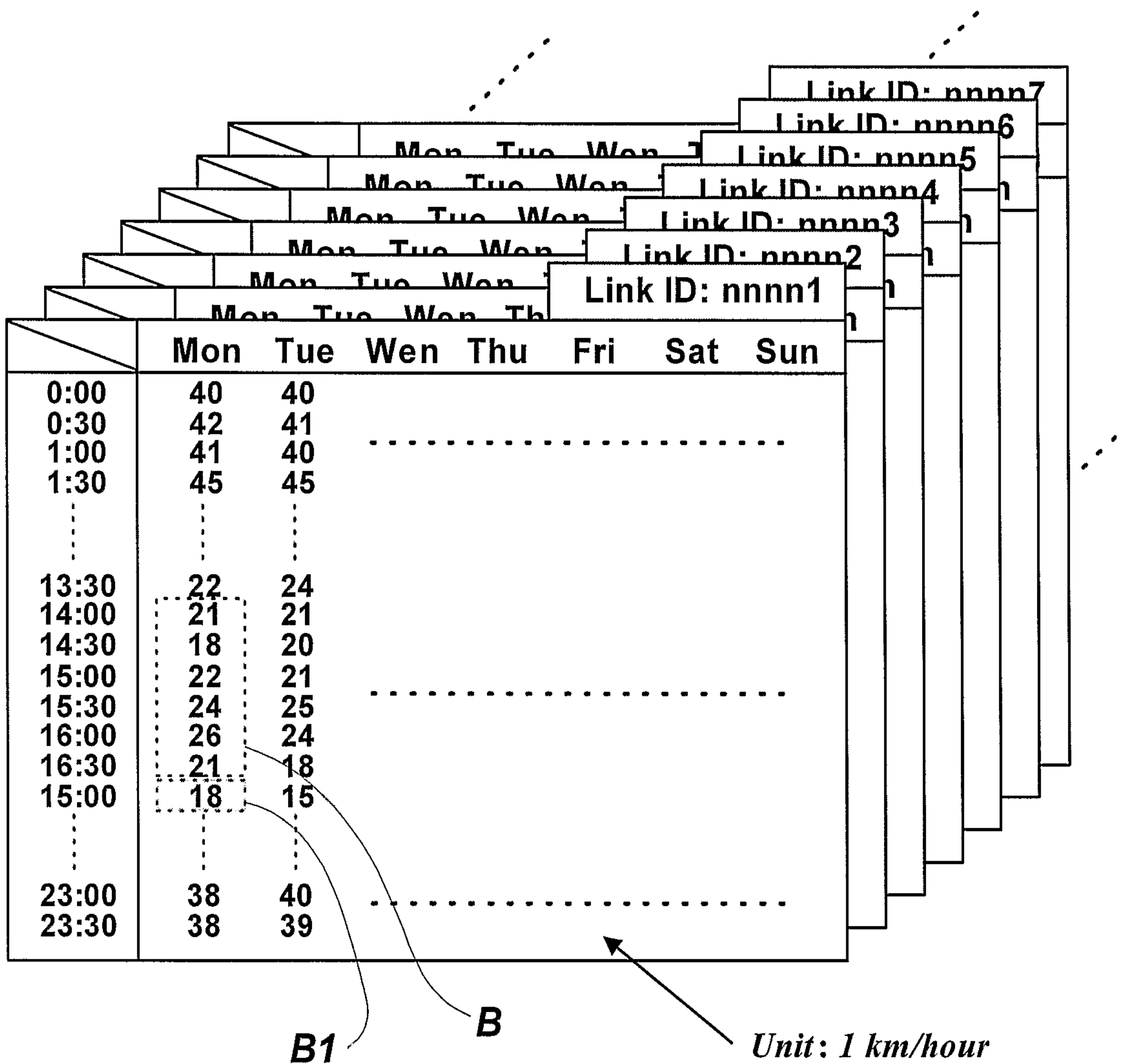

FIG. 5b

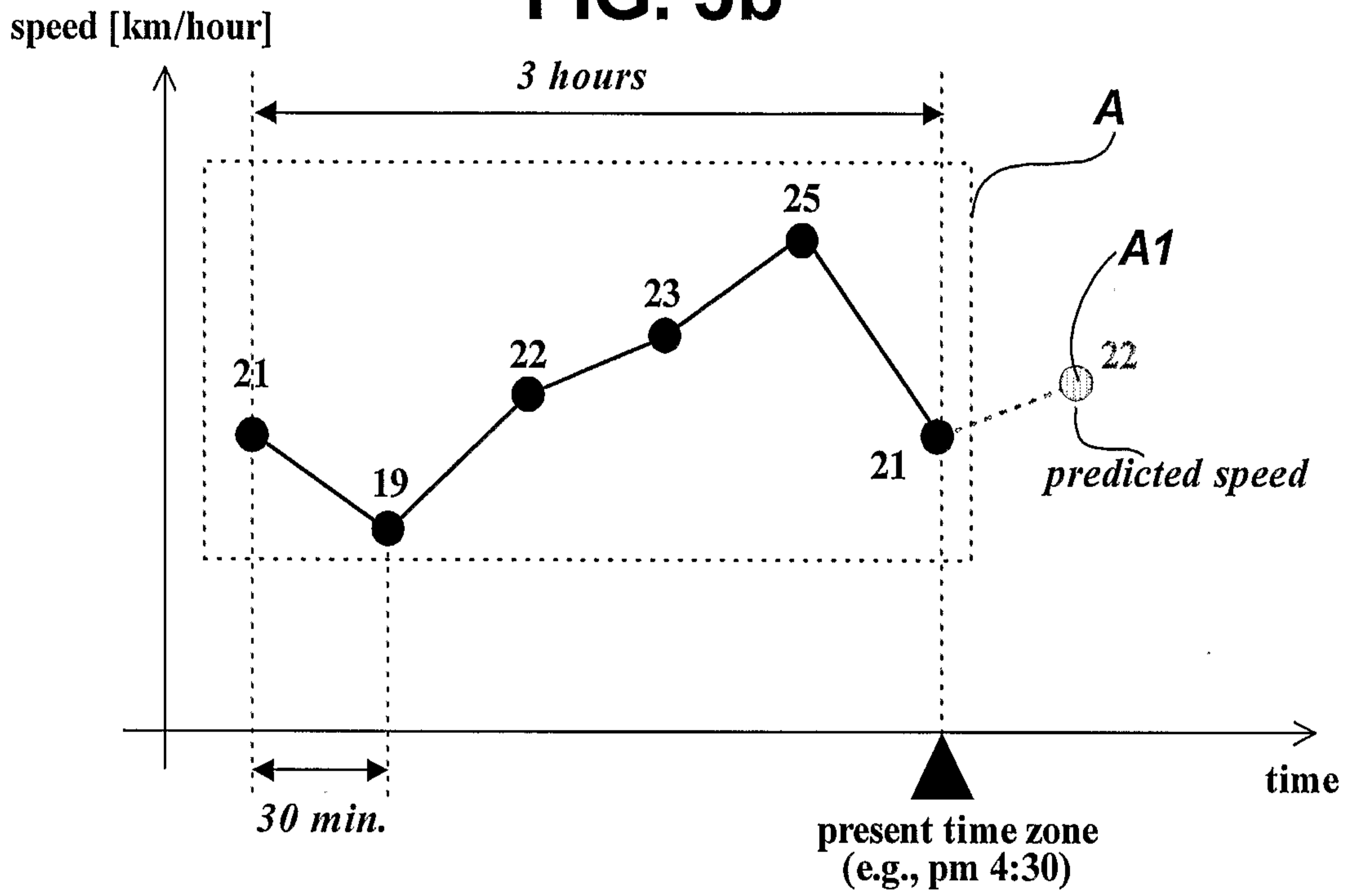

FIG. 6

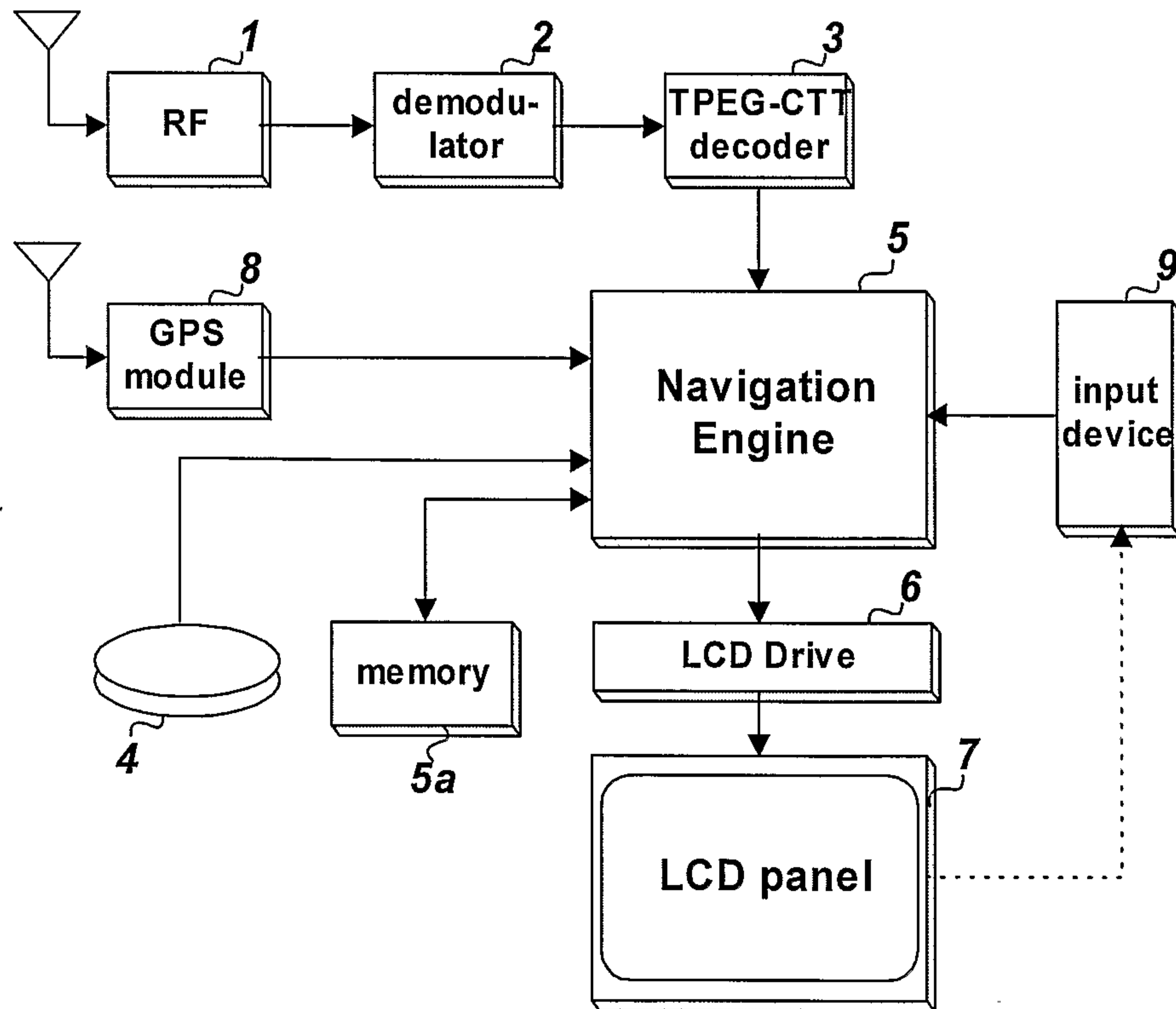

FIG. 7a

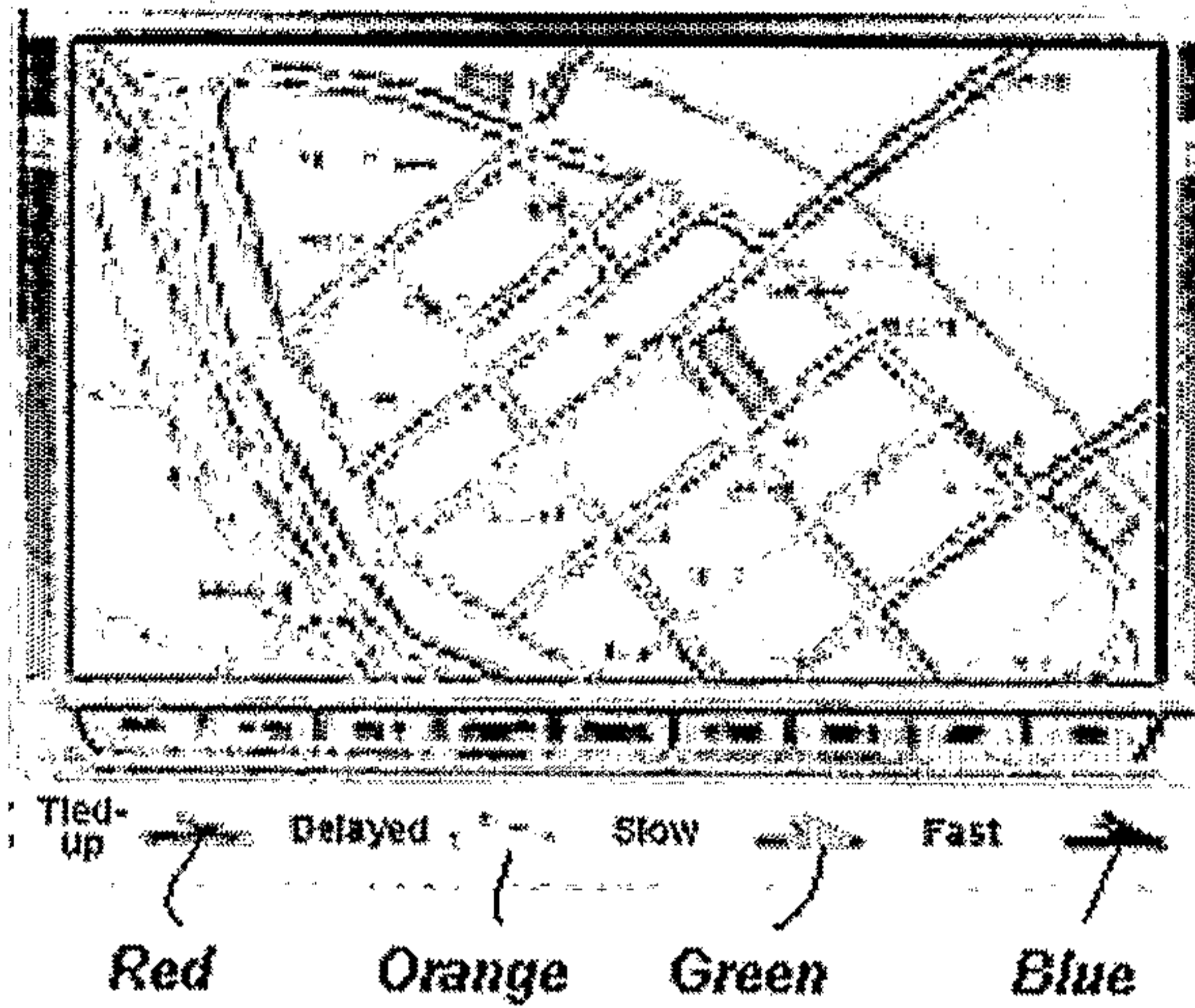

FIG. 7b

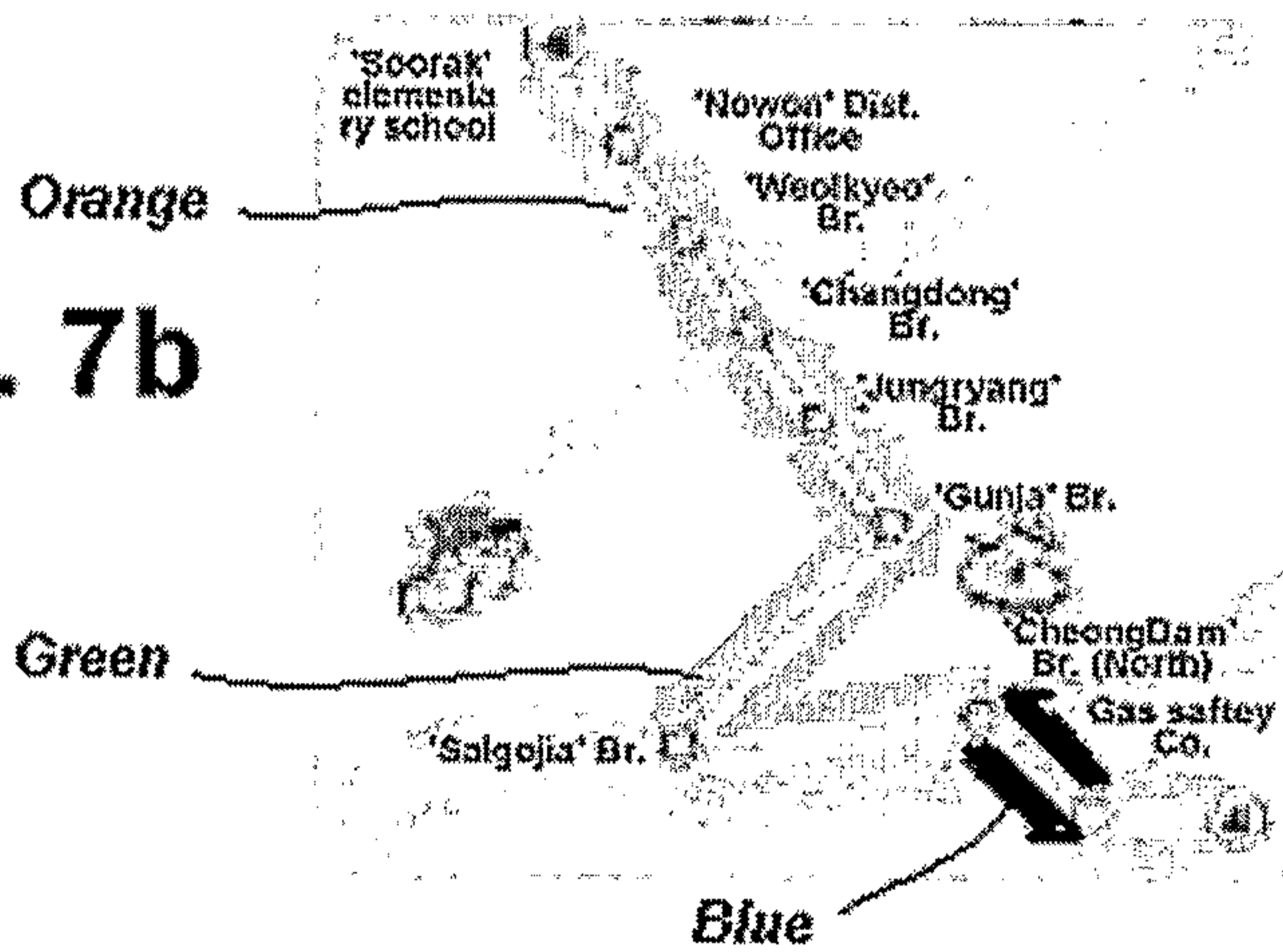

FIG. 7c

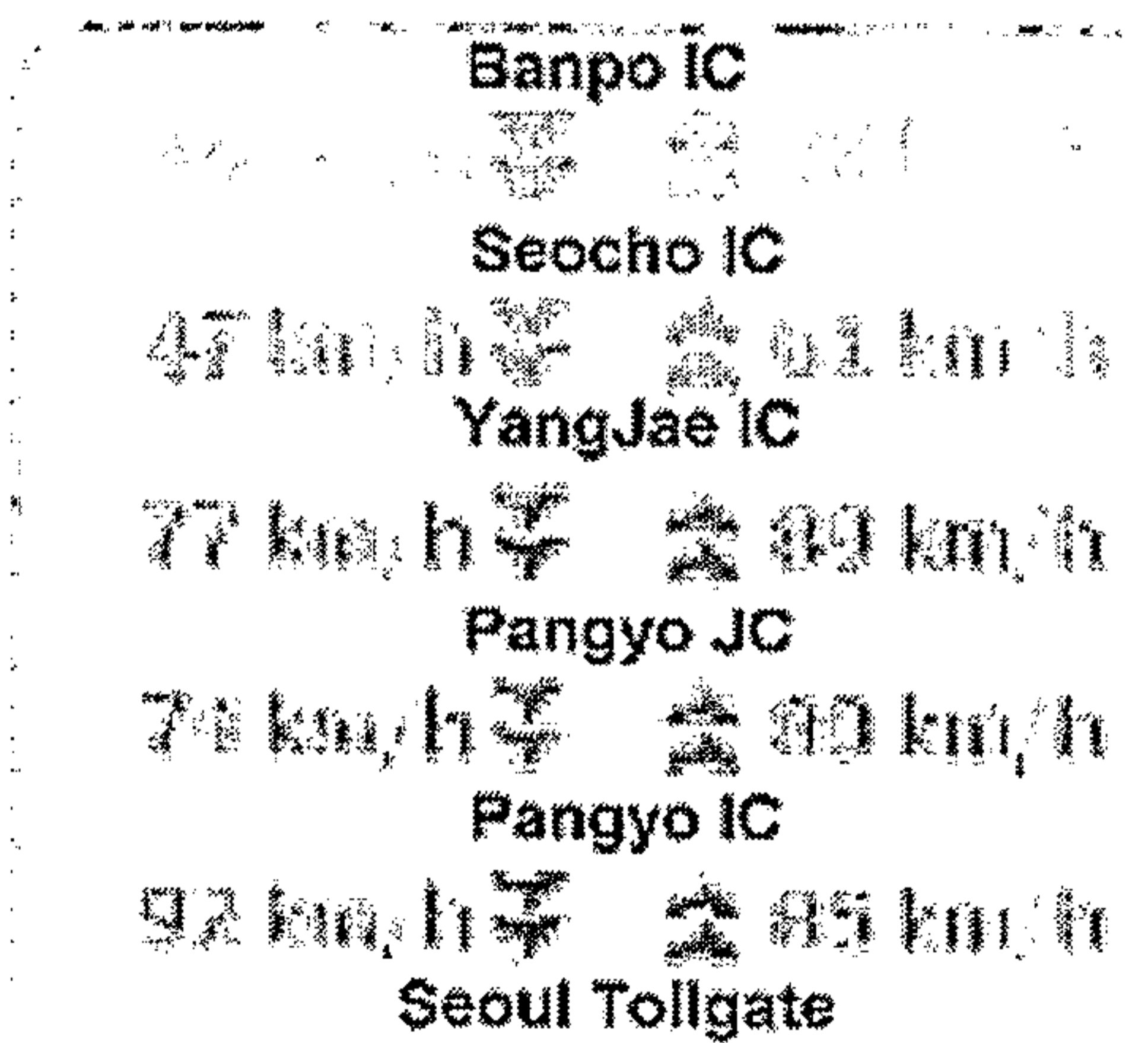

FIG. 8

