



- (51) **International Patent Classification:**
F25J 3/04 (2006.01) *E04H 5/10* (2006.01)
- (21) **International Application Number:**
PCT/US2018/014972
- (22) **International Filing Date:**
24 January 2018 (24.01.2018)
- (25) **Filing Language:** English
- (26) **Publication Language:** English
- (30) **Priority Data:**
62/450,181 25 January 2017 (25.01.2017) US
- (71) **Applicant: PRAXAIR TECHNOLOGY, INC.** [US/US];
10 Riverview Drive, Danbury, CT 06810 (US).
- (72) **Inventors: SABODA, Kevin J.**; 421 W. Broadway, Apt.
#2165, Long Beach, CA 90802 (US). **KIBLER, Karl
K.**; 9 Monarch Drive, Amherst, NY 14226 (US). **DE-
GENSTEIN, Nick J.**; 11 E. Sunlit Forest Drive, The Wood-
lands, TX 77381 (US).
- (74) **Agent: HAMPSCH, Robert J.** et al.; Praxair, Inc., 10
Riverview Drive, Danbury, CT 06810 (US).
- (81) **Designated States** (*unless otherwise indicated, for every
kind of national protection available*): AE, AG, AL, AM,

AO, AT, AU, AZ, BA, BB, BG, BH, BN, BR, BW, BY, BZ,
CA, CH, CL, CN, CO, CR, CU, CZ, DE, DJ, DK, DM, DO,
DZ, EC, EE, EG, ES, FI, GB, GD, GE, GH, GM, GT, HN,
HR, HU, ID, IL, IN, IR, IS, JO, JP, KE, KG, KH, KN, KP,
KR, KW, KZ, LA, LC, LK, LR, LS, LU, LY, MA, MD, ME,
MG, MK, MN, MW, MX, MY, MZ, NA, NG, NI, NO, NZ,
OM, PA, PE, PG, PH, PL, PT, QA, RO, RS, RU, RW, SA,
SC, SD, SE, SG, SK, SL, SM, ST, SV, SY, TH, TJ, TM, TN,
TR, TT, TZ, UA, UG, US, UZ, VC, VN, ZA, ZM, ZW.

- (84) **Designated States** (*unless otherwise indicated, for every
kind of regional protection available*): ARIPO (BW, GH,
GM, KE, LR, LS, MW, MZ, NA, RW, SD, SL, ST, SZ, TZ,
UG, ZM, ZW), Eurasian (AM, AZ, BY, KG, KZ, RU, TJ,
TM), European (AL, AT, BE, BG, CH, CY, CZ, DE, DK,
EE, ES, FI, FR, GB, GR, HR, HU, IE, IS, IT, LT, LU, LV,
MC, MK, MT, NL, NO, PL, PT, RO, RS, SE, SI, SK, SM,
TR), OAPI (BF, BJ, CF, CG, CI, CM, GA, GN, GQ, GW,
KM, ML, MR, NE, SN, TD, TG).

Declarations under Rule 4.17:

- *as to applicant's entitlement to apply for and be granted a
patent (Rule 4.17(ii))*
- *as to the applicant's entitlement to claim the priority of the
earlier application (Rule 4.17(iii))*

- (54) **Title:** STRUCTURAL SUPPORT ASSEMBLY FOR COLD BOX STRUCTURES IN AN AIR SEPARATION UNIT

(57) **Abstract:** A pre-fabricated or shop-built structural support assembly cold box structures containing distillation columns or other cold box equipment in an air separation unit is provided.

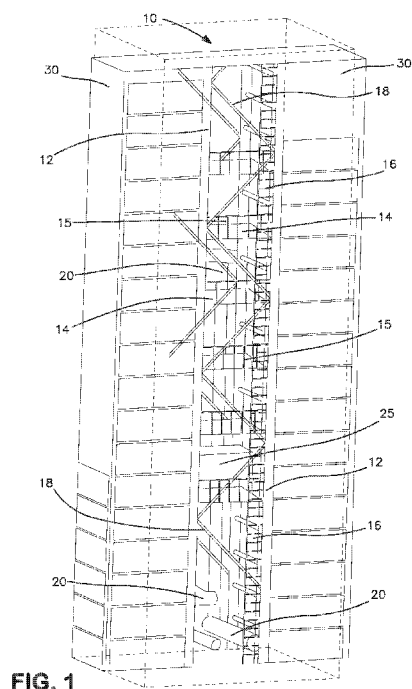

FIG. 1



WO 2018/140445 A1

Published:

— *with international search report (Art. 21(3))*

**STRUCTURAL SUPPORT ASSEMBLY FOR COLD BOX STRUCTURES
IN AN AIR SEPARATION UNIT**

Technical Field

(0001) The present invention relates to a pre-fabricated structural support assembly for cold box structures containing distillation columns or other cold box equipment for an air separation unit.

Background

(0002) The use of pre-fabricated packages that are readily transportable to a facility site for the construction of a cryogenic air separation unit has been previously described in United States Patent Application Publication Nos. 2015/0096327 and 2007/0199344 as well as United States Patent No. 5,461,871. Such pre-packaged units or modular units described in the prior art all are directed to operational or functional equipment (e.g. ‘cold-end’ equipment or ‘warm-end’ equipment) required for the cryogenic separation of air.

(0003) For example, in United States patent application publication No. 2015/0096327, the transportable package is a cold-box package unit that does not include the high pressure column or low pressure column of the air separation unit, the main heat exchanger or auxiliary columns such as the argon column, but rather includes a separate cold box that houses other cold-end equipment and accessories for the air separation unit such as condensers, piping/conduits and terminals for connecting the conduits to the high pressure column, low pressure column, auxiliary columns and to the main heat exchanger.

(0004) Likewise, in United States patent application publication No. 2007/0199344, the modular unit or package is a cold box package unit that specifically includes the rectification columns of the air separation unit and ancillary cold-end equipment such as the main heat exchanger.

(0005) The modular units described in United States Patent No. 5,461,871 also include operational or functional equipment required for the separation of air. However, the described modular units include both warm-end modules for warm-end

equipment such as air compression equipment, and air purification equipment as well as cold box modules containing cold-end equipment such as heat exchangers, subcoolers, cryogenic valves, cryogenic pumps, turbines, and rectification columns.

(0006) In the aforementioned prior art references, the pre-fabricated or shop built cold box packages for the 'cold-end' equipment are operatively coupled together via site work and field piping connections. The required site work further requires installing the cold box package, attaching the ladders, stairs, etc. to the modular or pre-packaged cold box and other finishing work. What is needed is a means to further reduce the field construction time of an air separation unit, and particularly, reduce field construction time of a cold box arrangement for an air separation unit by also providing a shop constructed or pre-fabricated structural support assembly which functions as a cold-box integration module.

Summary of the Invention

(0007) The present invention may be characterized as a pre-fabricated structural support assembly for an air separation unit, the pre-fabricated structural support comprising: (i) a structural frame; (ii) a plurality of platforms connected to the structural frame; (iii) at least one ladder or stairway connected to the structural frame or one or more of the plurality of platforms; and (iv) a plurality of piping or ducts connected to the structural frame or to the one or more of the plurality of platforms, the plurality of piping or ducts configured to be fluidically interconnected to one or more cold box structures of the air separation unit. The pre-fabricated structural support assembly is configured to be transported to a location of the air separation unit and further configured to be affixed and fluidically interconnected to one or more cold box structures of the air separation unit. The platforms are configured to support one or more persons and the at least one ladder or stairway is configured to connect the plurality of platforms and allow one or more persons to move between platforms and access to selected locations on the cold box structures. The plurality of piping or ducts are arranged or configured to fluidically interconnect the cold box structures of the air separation unit.

(0008) The pre-fabricated structural support assembly also may include a plurality of braces configured to provide partial structural support of the cold box structures against seismic forces and wind forces acting on the cold box structures. The plurality of platforms may also include one or more extendable platform that are configured to be retracted during transportation to keep an in-transit height and/or an in-transit width below a prescribed dimension, and further configured to be extended when affixed to the cold box structures of the air separation unit.

(0009) The pre-fabricated structural support assembly also may include one or more insulated enclosures that are configured to house cold-end equipment that is fluidically interconnected to at least one of the cold box structures of the air separation unit. Some or all of the plurality of piping or ducts as well as the insulated enclosure may be insulated with aerogel insulation.

Brief Description of the Drawings

(0010) While the specification concludes with claims specifically pointing out the subject matter that Applicant regards as the invention, it is believed that the invention will be better understood when taken in connection with the accompanying drawings in which;

(0011) Fig. 1 is an illustration of a pre-fabricated structural support assembly disposed between two cold box structures in an air separation unit in accordance with an embodiment of the present invention; and

(0012) Fig. 2 is a schematic illustration of a pre-fabricated structural support assembly supporting or connected to a plurality of cold box structures in an air separation unit in accordance with an alternate embodiment of the present invention.

Detailed Description

(0013) As well known in the art, oxygen, nitrogen and argon products are often produced from a compressed and purified feed air stream through a cryogenic rectification process in an air separation unit. Typically, such gaseous and/or liquid products are produced in an air separation unit for on-site customers or pipeline customers, with any excess products often converted to merchant liquid products for

nearby customers. An air separation unit commonly employs a Linde-type double column cryogenic air separation arrangement that includes a lower pressure distillation column, a higher pressure distillation column coupled together in a heat exchange relationship to recover oxygen and nitrogen, and optional third and/or fourth distillation columns (e.g. low ratio column and/or superstage column) to recover argon. In addition to the distillation columns, the air separation unit also includes pre-purification systems, compression equipment, a primary heat exchanger, one or more condensers, one or more auxiliary heat exchangers, a turbine based refrigeration system, as well as a plurality of pumps, valves, storage tanks, conduits/piping, etc.

(00014) As portions of the air separation process are conducted at cryogenic temperatures, air separation units will typically have one or more cylindrical or rectangular shaped cold boxes to house the distillation columns, heat exchangers, and other ‘cold-end’ equipment. Such cold box structures are typically designed and constructed to withstand the expected wind and/or seismic loads and in accordance with local building code requirements. Such cold box structures for air separation units may be shop built or, in many cases, field erected. In some cases, a hybrid construction approach may be employed where portions of the cold box structure are shop fabricated in a plurality of modules and then the modules are assembled together in the field to erect the final cold box structure.

(00015) Cold box structures for air separation units also typically have multiple access panels distributed along the height of the coldbox structure. To access these access panels, and thus the distillation column or other equipment disposed within the cold box structure, the cold box structures must have a series of stairs or ladders to allow personnel to climb up to the various access panels. Some air separation units use stairs that circumnavigate the cold box structures in a spiral pattern while other air separation units use ladders that are directly attached to the outer surface of the cold box structures.

(00016) Distillation columns for an air separation unit are also either shop built or field assembled. With shop fabrication, the distillation column for the air separation unit (including column internals) is fully assembled, piped, and often pre-

installed into a shop fabricated cold box structure. This final assembled cold box structure (including the distillation column) is then shipped to the field site and erected on a foundation. With field assembly of a distillation column, an empty or bare column shell is shipped to the field site in one or more pieces and then installed into a cold box structure. The required column internals and associated piping are typically installed after the distillation column is positioned in the cold box structure. Shop fabricated and assembled columns are generally preferred to field constructed columns, since shop fabrication and assembly is generally less expensive than field construction and assembly.

(00017) A hybrid alternative of distillation column construction is to install most of the required piping and column internals on-site but at ground level before the distillation column is raised and installed into the cold box structure. The advantage of installing piping and column internals at ground level in a field construction project is that it avoids elevated assembly and welding work in tight spaces. A disadvantage associated with installing the piping and column internals at ground level of the field site is the possibility of damaging the piping upon installation into the cold box structure and the crane weight loading requirements are increased.

(00018) As discussed in more detail below, the present invention is a pre-fabricated or shop-built structural support assembly configured to be disposed adjacent to or even between the cold box structures of an air separation unit. The structural support assembly is further configured to provide access to the cold box structures and the equipment contained therein and provides partial structural support for adjacent cold box structures as well as interconnecting piping between the cold box structures.

(00019) Turning now to Fig. 1, there is shown an illustration of a pre-fabricated structural support assembly supporting two cold box structures in an air separation unit. The pre-fabricated structural support assembly 10 for cold box structures 30 of an air separation unit, includes a structural frame 12 as well as a plurality of platforms 14 and railings 15 connected to the structural frame 12 to allow personnel to access selected locations on the cold box structures 30 during construction and operation of the air separation unit. The pre-fabricated structural support assembly 10 further

includes a plurality of stairways and/or ladders 16 (see also Fig. 2) connecting the plurality of platforms 14 such that personnel can climb up and down the structural support assembly 10 to access selected locations on the cold box structures 30 during construction and operation of the air separation unit. The pre-fabricated structural support assembly 10 preferably also includes pre-fabricated piping, ducts and/or conduits 20 to move the gas and fluid streams between selected locations on the cold box structures 30 and an insulated enclosure 25. As shown, the illustrated structural support assembly is preferably anchored in the ground or to a concrete foundation. A plurality of structural braces 18 connecting portions of the structural frame 12 are also shown.

(00020) The pre-fabricated structural support assembly 10 functions as a stand-alone cold-box integration module during both construction and operation that structurally and operatively couples the cold boxes of the air separation unit. As a pre-fabricated or shop built structure, the structural support assembly 10 is also configured to be transported to the site of the air separation unit via truck or other commercial carrier and is further configured to be easily lifted and then lowered into place between the cold box structures and then rigidly affixed to the separate cold box structures 30 of the air separation unit.

(00021) In Fig. 2, there is shown a schematic illustration of another embodiment of the pre-fabricated structural support assembly. As seen therein, the pre-fabricated structural support assembly 10 is connected to and/or supports multiple cold box structures 30 of an air separation unit, including the lower pressure distillation column, a higher pressure distillation column, a primary heat exchanger 36, and an argon or low ratio column. This embodiment of the pre-fabricated structural support assembly 10 also includes a structural frame 12; a plurality of fixed platforms 14 with railings 15 connected to the structural frame 12; a plurality of stairways and/or ladders 16 connecting the plurality of platforms 14; a plurality of extendable platforms 17; a plurality of structural braces 18 connecting portions of the structural frame 12; one or more insulated enclosures 25; and a series of pre-fabricated piping, ducts and/or conduits 20 (not shown in Fig. 2 but see Fig. 1)

arranged or configured to move gas and/or fluid streams between selected locations on the multiple cold box structures 30.

(00022) As with the previously described embodiment, the plurality of stairways and/or ladders 16 connecting the plurality of platforms 14 are arranged or configured such that personnel can climb up and down the structural support assembly 10 to the various platforms 14 (and extendable platforms 17) to access selected locations on the cold box structures 30 during construction and operation of the air separation unit.

(00023) The plurality of fixed platforms 14 together with the extendable platforms 17 (which are connected to the fixed platforms) allow personnel to access selected locations on the cold box structures 30 during construction and operation of the air separation unit. During transport of the pre-fabricated structural support assembly 10 to the installation site, the extendable platforms 17 are in a retracted position adjacent to the fixed platforms 14 and retained within the boundaries of the structural frame 12. Once the structural support assembly 10 is lowered into place at the installation site adjacent to two of the cold box structures, the extendable platforms 17 are slid outwardly from the structural frame extending towards the cold box structures in an extended position and bolted to the cold box structures. In situations where the structural support assembly 10 provides partial structural support to the cold box structures 30, the structural support assembly 10 preferably includes structural braces extending between portions of the structural frame 12 and/or the cold box structures 30.

(00024) In the illustrated embodiment of Fig. 2, the structural support assembly 10 is shown positioned on top of and anchored to a raised structure of the air separation unit, which could be another cold box structure. In addition, the structural support assembly 10 includes an elevated support base 19 proximate the top of the structural support assembly 10. The elevated support base 19 is configured to support one of the cold box structures 30 so as elevate a distillation column within the cold box structure to take advantage of gravity feed of one or more streams from the distillation column and eliminate the use of a pump (e.g. liquid reflux pump).

(00025) The external dimensions of the pre-fabricated structural support assembly usually determine the in-transit dimensions of the package. One such dimension is the height (h) of the structural support assembly 10 which is understood to represent the dimension in the vertical direction from the ground based on the orientation and positioning of the structural support assembly 10 when finally assembled as part of the air separation unit. The other salient dimensions are the width (w) and depth (d) of the structural support assembly 10 which are understood to represent the dimensions of the structural support assembly 10 as measured on a line or plane perpendicular to the vertical direction. In transit, the height of the structural support assembly determines the in-transit length while the width of the structural support assembly and depth of the structural support assembly defines the in-transit height and in-transit width.

(00026) The structural support assembly 10 is preferably pre-fabricated in a shop or factory which is generally remote from the installation site of the air separation unit. Such shop based pre-fabrication allows some minimization of the construction requirements and activities at the installation site, where environmental conditions are often much more difficult. Since the pre-fabricated structural support assembly 10 is typically transported from the shop or factory to the installation site via commercial vehicles such as a tractor trailer truck, there are various Department of Transportation (DOT) regulations and local restrictions as to the in-transit length, in-transit width, and in-transit height of the transported item.

(00027) In situations where the structural support assembly 10 includes pre-fabricated ducts, conduits, or other piping, such pre-fabricated piping 20 only needs to be welded on the ends to the associated piping of the cold box structures 30. Since a majority of this welding of the interconnecting piping could be done from the platforms¹⁴ (or extended platforms 17) on the structural support assembly 10 it would eliminate much of the elevated site work and scaffolding requirements currently used during construction of an air separation unit. In addition, where the structural support assembly 10 includes pre-fabricated piping, ducts or conduits, such items may be pneumatically pressure tested in the shop during fabrication thereby eliminating or minimizing the pneumatic test requirements that need to be performed on-site.

(00028) The structural frame 12 is preferably constructed from steel frame members and is arranged to define a generally open interior space. The pre-fabricated ducts, conduits, or other piping 20 of the structural support assembly 10 are generally arranged in the open interior space and terminate near edges of the structural frame 12 at locations that align with the locations of the corresponding piping in the cold box structures 30.

(00029) The structural frame 12 also preferably defines the dimensions of the structural support assembly 10 and allows the structural support assembly 10 to be efficiently packaged, shipped and lifted into place without damaging the piping 20 disposed in the open interior spaces. Using a pre-fabricated structural support assembly 10 that provides partial structural support of the cold box structures 30, it may be possible to reduce the height to base ratio of the cold box structures 30, which lowers the construction cost of the cold box structures 30 while still meeting the wind load requirements and other requirements of the local building codes. The lower construction costs are realized as a result of the significant reductions in the amount of structural steel in each cold box structures, making them less expensive, lighter, and easier to install.

(00030) One or more insulated enclosures 25 can be optionally designed into the pre-fabricated structural support assembly 10. The insulated enclosures 25 are preferably disposed on a platform 14 and sized to accommodate cold-end equipment that is too large or too heavy to install with the field interconnecting piping. Cold-end equipment such as superheaters, subcoolers, argon refineries, condensers, and liquid storage tanks can be located within the insulated enclosures 25 of the structural support assembly 10 along with the any required interconnecting piping which could free up space in the cold box packages for larger distillation columns or larger primary heat exchanger cores.

(00031) While the present invention has been described with reference to one or more preferred embodiments and operating methods associated therewith, it should be understood that numerous additions, changes and omissions to the disclosed system and method can be made without departing from the spirit and scope of the present invention as set forth in the appended claims.

Claims

What is claimed is:

1. A pre-fabricated structural support assembly for an air separation unit, the pre-fabricated structural support comprising:
 - a structural frame;
 - a plurality of platforms connected to the structural frame;
 - at least one ladder or stairway connected to the structural frame or one or more of the plurality of platforms; and
 - a plurality of piping or ducts connected to the structural frame or to the one or more of the plurality of platforms, the plurality of piping or ducts configured to be fluidically interconnected to one or more cold box structures of the air separation unit;wherein the platforms are configured to support one or more persons and the at least one ladder or stairway is configured to connect the plurality of platforms and allow one or more persons to move between platforms;
 - wherein the pre-fabricated structural support assembly is configured to be transported to a location of the air separation unit and further configured to be affixed and fluidically interconnected to one or more cold box structures of the air separation unit.
2. The pre-fabricated structural support assembly of claim 1, wherein the structural support assembly is configured to be anchored to a concrete foundation at the location of the air separation unit.
3. The pre-fabricated structural support assembly of claim 1, wherein the structural frame further comprises one or more braces configured to provide partial support of the one or more cold box structures against seismic forces and wind forces acting on the one or more cold box structures.

4. The pre-fabricated structural support assembly of claim 1, wherein at least one of the plurality of platforms further comprise at least one extendable platform that is configured to be retracted during transportation to keep an in-transit height and/or an in-transit width below a prescribed dimension, and the at least one extendable platform further configured to be extended when affixed to the one or more cold box structures of the air separation unit.
5. The pre-fabricated structural support assembly of claim 1, further comprising: one or more insulated enclosures disposed on at least one of the plurality of platforms.
6. The pre-fabricated structural support assembly of claim 5, wherein the one or more insulated enclosures are configured to house cold-end equipment selected from the group consisting of heat exchangers, subcoolers, condensers, expansion joints, storage vessels, cryogenic valves, cryogenic pumps, and cryogenic piping or combinations thereof.
7. The pre-fabricated structural support assembly of claim 1, wherein some or all of the plurality of piping or ducts are insulated with aerogel insulation.
8. The pre-fabricated structural support assembly of claim 1, wherein at least one of the plurality of piping or ducts is configured to be fluidically interconnected with at least two cold box structures of the air separation unit.
9. The pre-fabricated structural support assembly of claim 1, wherein at least one of the plurality of piping or ducts is configured to be fluidically interconnected between at least two locations on a single cold box structure of the air separation unit.

10. The pre-fabricated structural support assembly of claim 1, wherein the pre-fabricated structural support assembly is configured to fit on a trailer and transported via truck to the location of the air separation unit.

11. The pre-fabricated structural support assembly of claim 1, wherein the pre-fabricated structural support assembly is configured to fit on a rail car and transported via train to the location of the air separation unit.

12. The pre-fabricated structural support assembly of claim 1, further comprising one or more structural bases and configured to provide a base for the one or more cold box structures of the air separation unit wherein the one or more cold box structures of the air separation unit are disposed on the one or more structural bases such that the one or more cold box structures of the air separation unit are elevated off the ground.

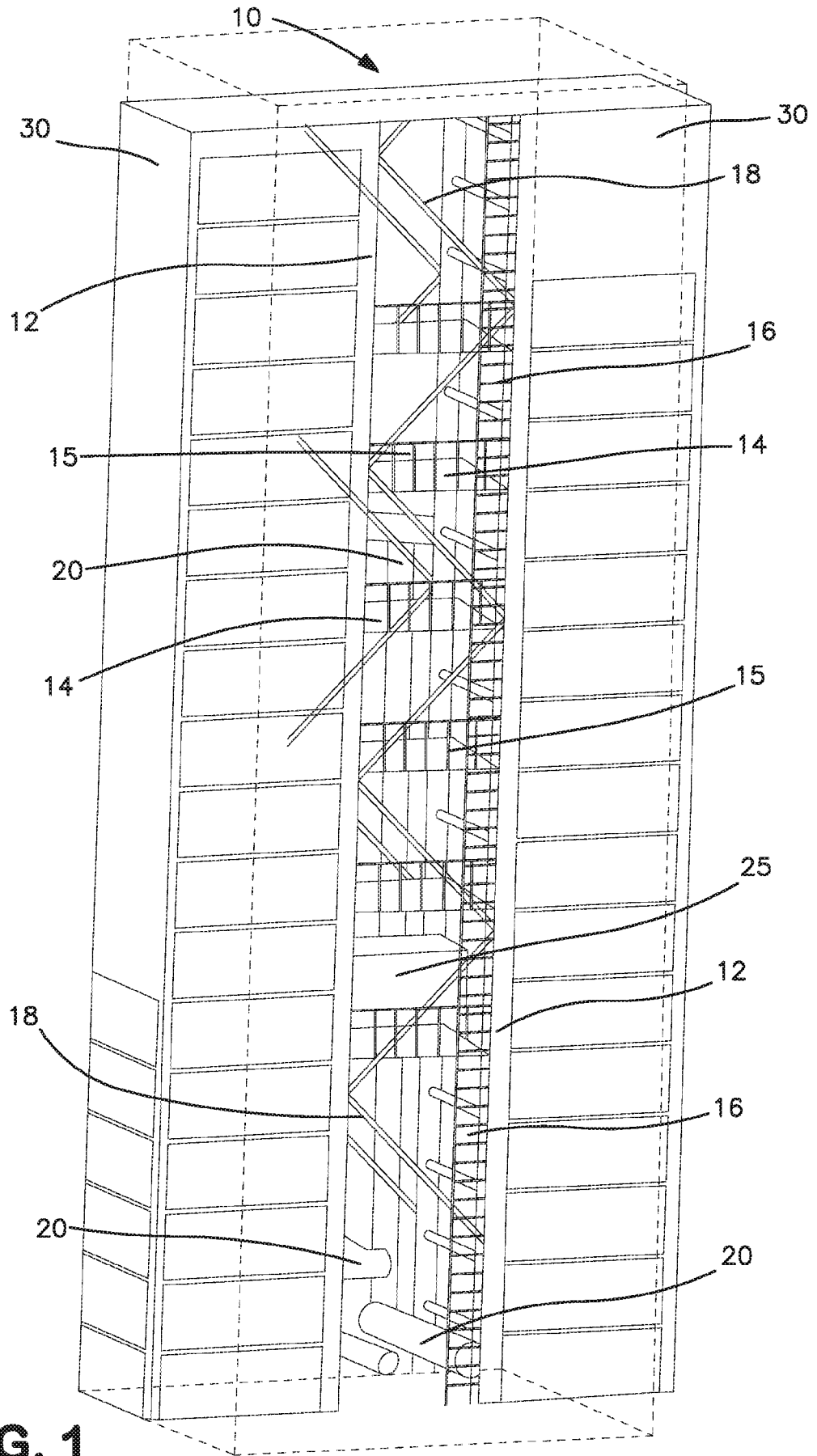

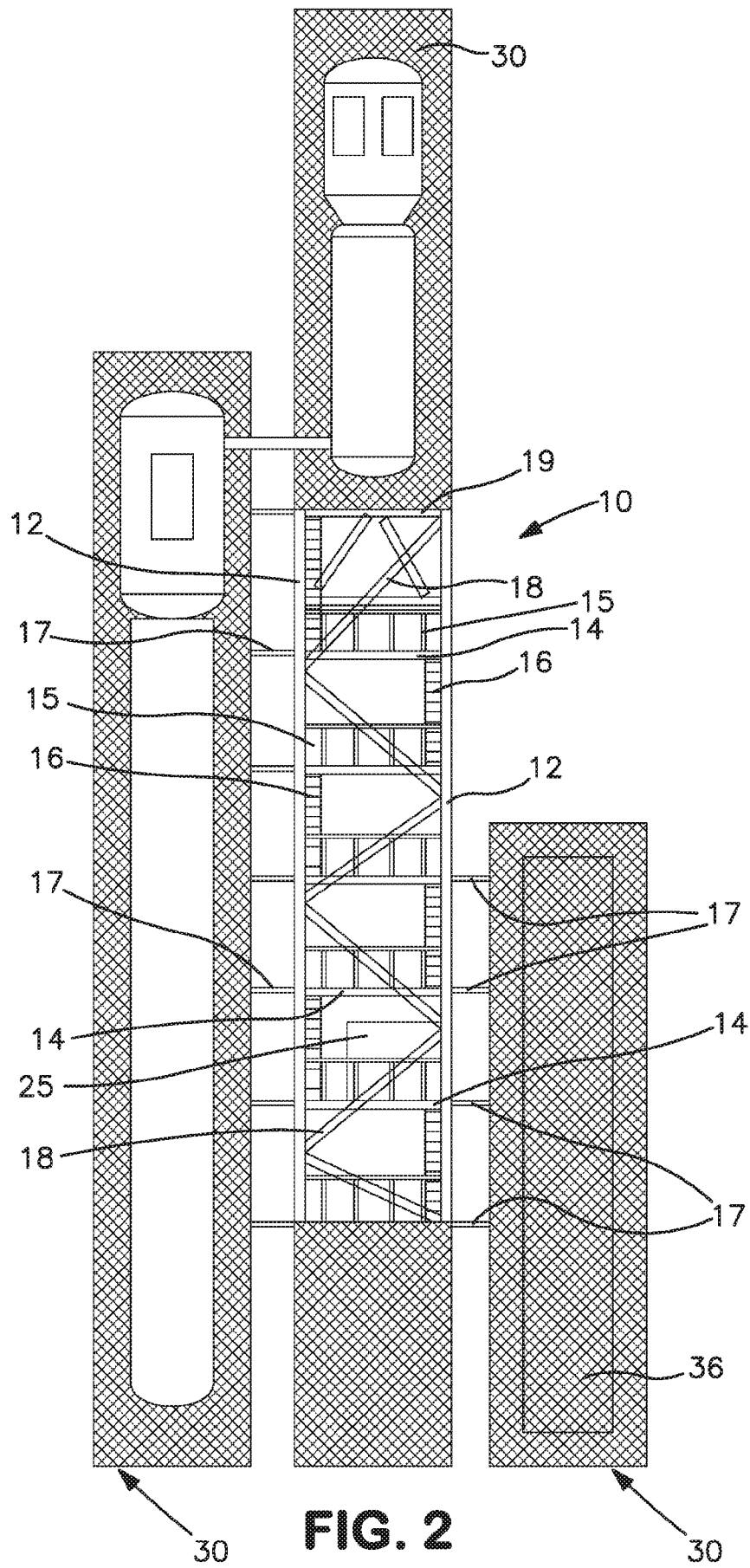

INTERNATIONAL SEARCH REPORT

International application No
PCT/US2018/014972

A. CLASSIFICATION OF SUBJECT MATTER
INV. F25J3/04 E04H5/10
ADD.
According to International Patent Classification (IPC) or to both national classification and IPC

B. FIELDS SEARCHED
Minimum documentation searched (classification system followed by classification symbols)
F25J E04H

Documentation searched other than minimum documentation to the extent that such documents are included in the fields searched

Electronic data base consulted during the international search (name of data base and, where practicable, search terms used)
EPO-Internal, WPI Data

C. DOCUMENTS CONSIDERED TO BE RELEVANT

Category*	Citation of document, with indication, where appropriate, of the relevant passages	Relevant to claim No.
X	US 9 051 749 B2 (AIR LIQUIDE PROCESS AND CONSTR) 9 June 2015 (2015-06-09)	1-3,5-12
A	column 3, line 46 - line 67; figure 2 column 2, line 66 - column 3, line 11 column 1, line 63 - line 67	4
A	GB 2 398 516 A (AIR PROD & CHEM [US]) 25 August 2004 (2004-08-25) page 3, line 25 - line 31	3
X	US 6 711 868 B1 (FAURE MARCEL [FR] ET AL) 30 March 2004 (2004-03-30) page 3; figures 1-4	1
A	JP 2002 347507 A (AIR WATER INC) 4 December 2002 (2002-12-04) figures 1,3	10,11
	----- -/--	

Further documents are listed in the continuation of Box C.

See patent family annex.

* Special categories of cited documents :

- "A" document defining the general state of the art which is not considered to be of particular relevance
- "E" earlier application or patent but published on or after the international filing date
- "L" document which may throw doubts on priority claim(s) or which is cited to establish the publication date of another citation or other special reason (as specified)
- "O" document referring to an oral disclosure, use, exhibition or other means
- "P" document published prior to the international filing date but later than the priority date claimed

"T" later document published after the international filing date or priority date and not in conflict with the application but cited to understand the principle or theory underlying the invention

"X" document of particular relevance; the claimed invention cannot be considered novel or cannot be considered to involve an inventive step when the document is taken alone

"Y" document of particular relevance; the claimed invention cannot be considered to involve an inventive step when the document is combined with one or more other such documents, such combination being obvious to a person skilled in the art

"&" document member of the same patent family

Date of the actual completion of the international search 7 March 2018	Date of mailing of the international search report 14/03/2018
--	---

Name and mailing address of the ISA/ European Patent Office, P.B. 5818 Patentlaan 2 NL - 2280 HV Rijswijk Tel. (+31-70) 340-2040, Fax: (+31-70) 340-3016	Authorized officer Schopfer, Georg
--	--

INTERNATIONAL SEARCH REPORT

International application No
PCT/US2018/014972

C(Continuation). DOCUMENTS CONSIDERED TO BE RELEVANT		
Category*	Citation of document, with indication, where appropriate, of the relevant passages	Relevant to claim No.
A	WO 2014/094288 A1 (AIR LIQUIDE [FR]; KURTZ Remy [CN]) 26 June 2014 (2014-06-26) figure 1	1-12
X	----- JP H07 158300 A (CHIYODA CHEM ENG CONSTRUCT CO) 20 June 1995 (1995-06-20) figures 1-4 -----	1

INTERNATIONAL SEARCH REPORT

Information on patent family members

International application No

PCT/US2018/014972

Patent document cited in search report	Publication date	Patent family member(s)	Publication date	
US 9051749	B2	09-06-2015	CA 2744363 A1	17-06-2010
			CN 102239303 A	09-11-2011
			EP 2376725 A1	19-10-2011
			ES 2391252 T3	22-11-2012
			JP 5657562 B2	21-01-2015
			JP 2012511649 A	24-05-2012
			KR 20110114534 A	19-10-2011
			US 2010139208 A1	10-06-2010
			WO 2010067253 A1	17-06-2010

GB 2398516	A	25-08-2004	AT 339571 T	15-10-2006
			AU 2004213622 A1	02-09-2004
			CN 1751163 A	22-03-2006
			DE 602004002389 T2	20-09-2007
			EP 1595042 A1	16-11-2005
			GB 2398516 A	25-08-2004
			US 2006144684 A1	06-07-2006
			WO 2004074603 A1	02-09-2004
			ZA 200507104 B	29-11-2006

US 6711868	B1	30-03-2004	AR 016959 A1	01-08-2001
			AU 736839 B2	02-08-2001
			BR 9803895 A	14-12-1999
			CA 2249888 A1	14-04-1999
			CN 1216819 A	19-05-1999
			DE 69814792 D1	26-06-2003
			DE 69814792 T2	18-03-2004
			EP 0913653 A1	06-05-1999
			FR 2769656 A1	16-04-1999
			JP 4248632 B2	02-04-2009
			JP H11190588 A	13-07-1999
			US 6711868 B1	30-03-2004
			ZA 9809248 B	17-06-1999

JP 2002347507	A	04-12-2002	NONE	

WO 2014094288	A1	26-06-2014	NONE	

JP H07158300	A	20-06-1995	JP 3242775 B2	25-12-2001
			JP H07158300 A	20-06-1995
