

(19) World Intellectual Property Organization
International Bureau



(43) International Publication Date
1 September 2011 (01.09.2011)

(10) International Publication Number
WO 2011/106197 A2

- (51) International Patent Classification:
G06F 17/26 (2006.01) *G06F 17/30* (2006.01)
- (21) International Application Number:
PCT/US2011/024878
- (22) International Filing Date:
15 February 2011 (15.02.2011)
- (25) Filing Language: English
- (26) Publication Language: English
- (30) Priority Data:
61/307,702 24 February 2010 (24.02.2010) US
12/828,200 30 June 2010 (30.06.2010) US
- (71) Applicant (for all designated States except US): **DEMAND MEDIA, INC.** [US/US]; 1333 Second Avenue, Suite 100, Santa Monica, California 90401 (US).
- (72) Inventors; and
- (75) Inventors/Applicants (for US only): **YEHASKEL, David M.** [US/US]; 2606 Cascade Drive, Austin, Texas 78757 (US). **KJALLBRING, Henrik M.** [US/US]; 2106-A Glendale Place, Austin, Texas 78704 (US).
- (74) Agent: **WARD, John P.**; Greenberg Traurig, LLP, 2450 Colorado Avenue Suite 400 East, Santa Monica, California 90404 (US).

- (81) Designated States (unless otherwise indicated, for every kind of national protection available): AE, AG, AL, AM, AO, AT, AU, AZ, BA, BB, BG, BH, BR, BW, BY, BZ, CA, CH, CL, CN, CO, CR, CU, CZ, DE, DK, DM, DO, DZ, EC, EE, EG, ES, FI, GB, GD, GE, GH, GM, GT, HN, HR, HU, ID, IL, IN, IS, JP, KE, KG, KM, KN, KP, KR, KZ, LA, LC, LK, LR, LS, LT, LU, LY, MA, MD, ME, MG, MK, MN, MW, MX, MY, MZ, NA, NG, NI, NO, NZ, OM, PE, PG, PH, PL, PT, RO, RS, RU, SC, SD, SE, SG, SK, SL, SM, ST, SV, SY, TH, TJ, TM, TN, TR, TT, TZ, UA, UG, US, UZ, VC, VN, ZA, ZM, ZW.
- (84) Designated States (unless otherwise indicated, for every kind of regional protection available): ARIPO (BW, GH, GM, KE, LR, LS, MW, MZ, NA, SD, SL, SZ, TZ, UG, ZM, ZW), Eurasian (AM, AZ, BY, KG, KZ, MD, RU, TJ, TM), European (AL, AT, BE, BG, CH, CY, CZ, DE, DK, EE, ES, FI, FR, GB, GR, HR, HU, IE, IS, IT, LT, LU, LV, MC, MK, MT, NL, NO, PL, PT, RO, RS, SE, SI, SK, SM, TR), OAPI (BF, BJ, CF, CG, CI, CM, GA, GN, GQ, GW, ML, MR, NE, SN, TD, TG).

Declarations under Rule 4.17:

- as to applicant's entitlement to apply for and be granted a patent (Rule 4.17(ii))

[Continued on next page]

(54) Title: RULE-BASED SYSTEM AND METHOD TO ASSOCIATE ATTRIBUTES TO TEXT STRINGS

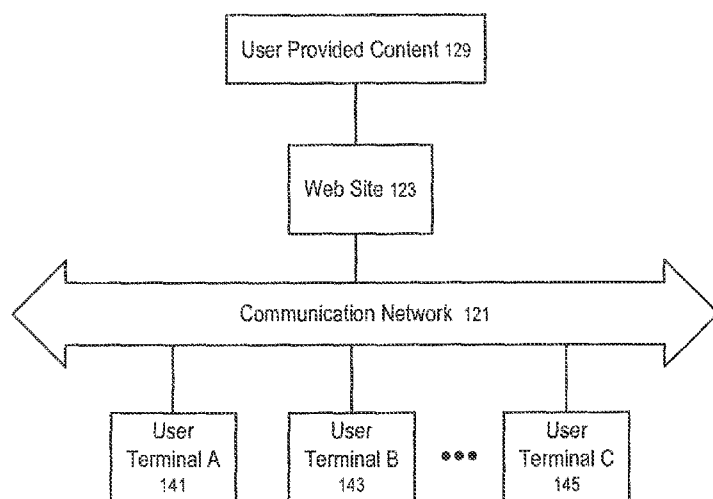

FIG. 1

(57) Abstract: In one embodiment, a title is selected for content to be published online. A method implemented in a data processing system includes receiving a plurality of text strings. A plurality of rules are applied to the text strings. If a condition specified in one of the rules exists in a given text string, one or more attributes are associated to that text string as metadata. One or more of the text strings are selected, using the metadata, as a potential title for the content. A final title is prepared based on the potential title, and the content is published online under the final title.

WO 2011/106197 A2

Published:

- *without international search report and to be republished upon receipt of that report (Rule 48.2(g))*

RULE-BASED SYSTEM AND METHOD TO ASSOCIATE
ATTRIBUTES TO TEXT STRINGS

CROSS-REFERENCE TO RELATED APPLICATIONS

[0001] This application claims benefit of Provisional Application Ser. No. 61/307,702, filed Feb. 24, 2010, and U.S. Application No. 12/828,200 filed June 30,2010, both entitled “Rule-Based System and Method to Associate Attributes to Text Strings,” the entire contents of which are incorporated by reference as if fully set forth herein.

FIELD

[0002] At least some embodiments disclosed herein relate generally to the field of electronic information processing and, more particularly but not limited to, associating one or more attributes to text strings (e.g., search queries) that satisfy one or more conditions in a plurality of rules.

BACKGROUND

[0003] The Internet provides a convenient way to interact and to request various types of information. People can use the Internet, for example, to communicate with each other, share information, and organize virtual communities (e.g., a social network).

[0004] One way of requesting information using the Internet is by using a search tool on a web site (e.g., Google search service). Some search tools allow a user to search using a search query. For example, a user may enter a location and a query for “Italian restaurants” to identify Italian restaurants in a specified area or location. Various web sites, including some social networks, are able to accept search queries from users. A search query indicates the information that a user is seeking.

[0005] Search services typically log search queries executed on such services. These query logs can provide a rich source of information which can be mined to gain insight into topics that are of interest to users. Such information, however, can be voluminous, potentially involving millions of queries. The identification of matter of interest in such query logs can therefore, be greatly facilitated by automated processing.

BRIEF DESCRIPTION OF THE DRAWINGS

[0006] The embodiments are illustrated by way of example and not limitation in the figures of the accompanying drawings in which like references indicate similar elements.

[0007] **Figure 1** shows a system including a web site accessible by user terminals according to one embodiment.

[0008] **Figures 2A-2B** show an example of a set of rules and corresponding attributes to be added to matching search queries according to one embodiment.

[0009] **Figures 3A-3D** show exemplary dictionary lists used in search query processing according to one embodiment.

[0010] **Figures 4A-4B** show an exemplary list of attributes and their mappings to other attributes according to one embodiment.

[0011] **Figures 5A-5B** show exemplary tags or attributes for output search queries according to one embodiment.

[0012] **Figure 6** shows a block diagram of a data processing system which can be used in various embodiments.

[0013] **Figure 7** shows a block diagram of a user device according to one embodiment.

DETAILED DESCRIPTION

[0014] The following description and drawings are illustrative and are not to be construed as limiting. Numerous specific details are described to provide a thorough understanding. However, in certain instances, well known or conventional details are not described in order to avoid obscuring the description. References to one or an embodiment in the present disclosure are not necessarily references to the same embodiment; and, such references mean at least one.

[0015] Reference in this specification to “one embodiment” or “an embodiment” means that a particular feature, structure, or characteristic described in connection with the embodiment is included in at least one embodiment of the disclosure. The appearances of the phrase “in one embodiment” in various places in the specification are not necessarily all referring to the same embodiment, nor are separate or alternative embodiments mutually exclusive of other embodiments. Moreover, various features are described which may be exhibited by some embodiments and not by others. Similarly, various requirements are described which may be requirements for some embodiments but not other embodiments.

[0016] Systems and methods to associate one or more attributes to text strings (e.g., search queries) that satisfy one or more conditions in a plurality of rules are described herein (e.g., use of these attributes and rules to select a title or to select a user recommendation). The disclosure includes methods and apparatuses which perform these methods, including data processing systems which perform these methods, and computer readable media containing instructions which when executed on data processing systems cause the systems to perform these methods. Other features will be apparent from the accompanying drawings and from the detailed description which follows.

[0017] In one embodiment, a title is selected for content (e.g., an article or video) to be published online. A method is implemented in a data processing system that includes receiving a plurality of text strings (e.g., search queries previously entered by users on affiliated websites). A plurality of rules are applied to the text strings, including parsing each of the respective text strings (e.g., into parts of speech) in order to apply the rules. Types of text strings may include, for example, a keyword phrase or a text string corresponding to an online search query previously received by a website.

[0018] If a condition specified in one of the rules exists in a given text string, one or more attributes (e.g., tags) are associated to that text string as metadata. One or more of the text

strings are selected, using the metadata, as a potential title for the content. A final title is prepared based on the potential title, and the content is published online under the final title. For example, the final title may be prepared by further human editing of the potential title, by selection of the potential title by a human from a short list of possible titles, and/or by further transformative processing using additional linguistic or other rules. For example, in some embodiments, prior to publishing the content, the potential title may be transformed (e.g., further automatically modified or edited) in preparation for use as a final title using an additional, separate set of rules. One of these rules may associate a plurality of similar word variations with a single attribute that is then associated with the search query.

[0019] The online content to be published may include, for example, text, music, pictures, graphics, cartoons, audio narratives, videos, movies, and the like. The content may be published, for example, on a website accessible over the Internet and/or a private intranet. Other forms in which content may be published to be available for online access include, for example, blogs, real simple syndication (RSS) feeds, audio streams, video streams, File Transfer Protocol (FTP) sites, and the like.

[0020] In one embodiment, the content is created by freelance writers or content creators. A final title is sent to a creator with a request to author the content. The content is created to be consistent with the final title and to be consistent with predefined guidelines provided to the creator. Articles that are related may be provided as background information. Metadata, such as key words obtained from some of the text strings to which the rules have been applied may be provided to the creator for inclusion in the content. An editorial team may then approve the completed article prior to publication. The creator may be paid for the content based on actual online viewings by users of the Internet or other electronic forms of access.

[0021] In one embodiment, in order to determine desirable potential titles, search queries used by users may be obtained from a large number of various web sites. For example, search queries may come from a company's affiliated web sites, bulk data purchased from search engines, Internet marketing firms, and/or Internet Service Providers (ISPs).

[0022] **Figure 1** shows a system including a web site 123 accessible by user terminals according to one embodiment. In **Figure 1**, the user devices or terminals (e.g., 141, 143, ..., 145) are used to access a web site 123 over a communication network 121 (e.g., the Internet, a wide area network, or a local area network). The web site 123 may include one or more web servers

(or other types of data communication servers) to communicate with the user terminals (e.g., 141, 143, ..., 145).

[0023] The web site 123 may be connected to a data storage facility to store user provided content 129, such as multimedia content, or preference data, etc. Search queries or text strings received from users may be stored in the data storage facility.

[0024] In some embodiments, the web site 123 also may provide search results in response to a searching user's search query or other information request. For example, the web site 123 may select information that is most relevant based on the search query.

[0025] In other embodiments, web site 123 may receive text strings from many different sources. For example, web site 123 may be coupled via communication network 121 to other web sites or servers that receive search queries or text strings (e.g., from data provided manually or automatically by user devices). Web site 123 may be configured to automatically receive or periodically request these text strings, which are stored for text string processing as described below. For example, a data processing system may automatically receive a plurality of search queries previously submitted by users on a plurality of websites. The data processing system is communicatively coupled (e.g., by Internet connections) to receive search queries from each server associated with one of the websites. In some embodiments, the text strings are aggregated from existing content (e.g., numerous short articles or stories).

[0026] In yet other embodiments, web site 123 may be used to publish content having a final title based on selected potential titles as described herein. The final title is derived from a selected potential title. Humans may be presented with several potential titles using a user terminal in order to select the final title. Each presented potential title may have been selected using the rules approach described herein.

[0027] In another embodiment, prior to selecting a final title and publishing the content, the online monetization values of a potential title and one or more alternative titles is compared. In one embodiment, the monetization value of search titles can be represented as a lifetime value (LTV). Techniques for calculating the LTV of a potential title are described in detail in U.S. Patent Application Ser. No. 12/826,524, filed Jun. 29, 2010, entitled "System and Method for Evaluating Search Queries to Identify Titles for Content Production," the entire contents of which are incorporated by reference as if fully set forth herein. Techniques for calculating the LTV of search terms are described in detail in U.S. Patent App. No. 12/337,550, entitled

“Method and System for Ranking of Keywords,” the entire disclosure of which is included by reference herein in its entirety.

[0028] In some embodiments, a combination of client server architecture and peer to peer architecture can be used, in which one or more centralized server may be used to provide some of the information and/or services and the peer to peer network is used to provide other information and/or services. Embodiments of the disclosure are not limited to a particular architecture.

[0029] **Figures 2A-2B** show an example of a set of rules (listed in the leftmost column) and corresponding attributes (in the corresponding rows in the columns to the right) to be added to matching search queries according to one embodiment. Here, the attributes are Deliver, Intent, Query, and Tags. Here, the text strings are a plurality of search queries. These attributes are associated with a search query if a condition in a rule is satisfied (i.e., the rule “fires”). As an example, the rules may be implemented in various forms of expert systems.

[0030] In one embodiment, before the set of rules are applied, the search queries may be treated to a small extent. For example, this treatment may include correcting commonly misspelled words. Also, some text may be normalized. Many queries are very similar and share the same informational goals. Rules may be written for specific instances. For example, several search queries (e.g., “get rid of ants”, “get rid ants”, “how to get rid of ants”) may be simplified into a single query (e.g., “How to Get Rid of Ants”). The rules are then applied to this single, treated query.

[0031] In one embodiment, the plurality of search queries (either fully un-structured, or as treated as discussed above) are parsed (e.g., the text is tokenized) and each search query is run against a subset or all of the rules. The parsing may include, for example, identifying one or more of the following: patterns in text strings, parts of speech, one or more specific words, and word combinations. These rules may contain one or more of the following: text strings, wildcards, word count, parts of speech, and dictionary matches. Rules may in some cases be fairly basic (e.g., look or test for one specific text string), or may be more detailed (e.g., look for multiple variables and conditions). Examples of various rules are described below.

[0032] Typically, the rules permit learning various types of information about the individual search queries, and further permit a selection of one or more search queries as potential titles (titles more or most likely to be turned into or used as final titles for published content). The

rules are an input used to identify specific conditions and then to assign the relevant attributes as an output when those conditions are met. This input/output process may sometimes be referred to herein as the “Keyword Processor.”

[0033] **Figures 3A-3D** show exemplary dictionary lists used in search query processing according to one embodiment. As mentioned above, some rules may test for the existence of one or more words from a search query that match a word in one or more dictionaries as defined in the particular rule. In one example, approximately 350 dictionaries (e.g., lists of words, text, numbers, and/or phrases) are used by the rules to discover, disambiguate and identify attributes of search queries. Many additional dictionaries may be used (e.g., thousands or potentially hundreds of thousands or more).

[0034] In some embodiments, disambiguation assists in determining what a word is referring to so that a decision can be made about the viability of the title and also its categorization. For example, the word “bills” could be a possessive noun/name, a financial document, a part of a hat, or a football team. Each of these contexts is significantly different, so knowing the meaning of “bills” that is intended by a person using it (e.g., a user doing a search) is helpful to selecting potential titles.

[0035] In one embodiment, dictionaries are named for reference. Dictionaries may be, for example, lists that contain one or more words or phrases, making it easier for rules to reference that group of words or phrases, without having to enumerate each and every one of those words or phrases repeatedly. Dictionaries may also contain further specifications than just the word or phrase itself. For example, the word or phrase may contain a wildcard character, symbolized by a % (percent sign) symbol, to serve as a substitute for any other text characters. For example, the text string “birth%” would match any word that merely started with the letters “b-i-r-t-h” such as “birthing”, ”births”, ”birthday”, ”birthdays”, etc.

[0036] As one specific example, in **Figure 3A** “babies-supplies” is one dictionary of many illustrated that may be referenced by a rule. For this particular dictionary, a rule may look for the word “baby” (or alternatively, babies, infant, infants, etc.) and in addition also look for another one of the many ambiguous words in the “babies-supplies” dictionary in order to infer that the search query is indeed about a product for babies. The foregoing may also be combined with other common words in another dictionary that lists shopping-related words in order to conclude that the query is transactional in nature and topically about baby supplies.

[0037] In some embodiments, dictionaries may consist of ambiguous and/or unambiguous words that share a general or specific theme. For example, the three dictionaries cars-make, cars-model, cars-year may include the following entries:

<i>cars-make</i>	<i>cars-model</i>	<i>cars-year</i>
Acura	Acadia	01
Alfa Romeo	Accent	02
Audi	Acclaim	03
Bentley	Accord	04
BMW	Achieva	05
Buick	Aerio	06
Cadillac	Aerostar	07
Chevrolet	Alero	08
Chrysler	Allante	09
Daewoo	allroad	'01
Daihatsu	Alpina	'02
Dodge	Altima	'03
Eagle	Amanti	'04
Ferrari	Amigo	'05
Ford	APV	'06
Geo	Aries	'07
GM	Armada	'08
GMC	Ascender	'09
Honda	Aspen	2001
Hummer	Aspire	2002

[0038] Now discussing rules and attributes in more detail, when the conditions of a rule are met, descriptive attributes get appended to matching search queries. A few types of attributes are now discussed below. In one embodiment, the attributes associated with a search query may be one or more of the following: one or more text tags; an indication of intent; a query type; an indication of suitability for use as a title; or one or more “extracted tags” (e.g., text extracted from a search query when and in response to a rule being satisfied, as discussed further below).

[0039] The query types may include, for example, the following types: informational, transactional, and navigational. For example, in a search context these are conventional type names that refer to informational goals sought by users of search engines. The following are specific examples of certain types: (i) the informational type typically relates to what persons want (e.g., people looking for information about something); (ii) the transactional type typically relates to shopping (e.g., “Tickets to New York”); and (iii) the navigational type typically relates to searches in which a person is looking for a website (e.g., “Google” or “best buy web site” or “best buy Austin texas”).

[0040] Regarding the Deliver attributes, queries marked with “Y” (e.g., see **Figure 2A**) are to be sent for further human review and editing; these queries generally have a much higher likelihood of being turned into final titles (e.g., 60-70% probability). Queries marked with an “N” are specifically undeliverable or unusable as a title because the search query has been identified as containing an undesirable element (e.g., as listed in a predefined list of undesirable elements).

[0041] Regarding the Intent attributes, queries marked with a “Y” attribute have clear and discernable intent (i.e., the person that submitted the search query had an intent to do something as discerned by one or more rules). Queries marked with an “N” attribute specifically lack clear intent. In one embodiment, only queries that are marked Deliver = Y and Intent = Y will be used as potential titles. In other embodiments, the remaining queries not so marked may be used for other purposes such as general Topic Pages or other forms of content (e.g., pictures, downloads, etc.).

[0042] Regarding the Query attributes, one or more rules identify if the search query fits into the three main types of search: Informational, Transactional or Navigational. The query is marked with the appropriate attribute.

[0043] Regarding the Tags attributes: tags may be free-form text used to identify other attributes of search queries. Various exemplary tag attributes may be used as follows:

1. Topical tags (e.g., pets, home, kids, health, etc.)
2. Type tags: objective (e.g., history or instructions) and subjective (e.g., reviews or advice) groupings
3. Action tags (e.g., building, repairing, finding, etc.)
4. Format tags: search query matches a potential title with a predefined template

[0044] Regarding the Extracted Tags attributes, specific, individual words are extracted from relevant rules-fired dictionaries (i.e., the one or more dictionaries for which a rule’s condition has been satisfied). The words are automatically appended as additional information to the search query. An extracted tag differs from a tag above in that the appended word is extracted from the search query itself in response to at least one rule condition involving a dictionary being

satisfied. In contrast, the tags above append a word as additional information to the search query that was predefined in the rule itself.

[0045] In one embodiment, a first plurality of rules to be applied includes a first rule. If a condition specified in the first rule exists in a search query, one or more words are extracted from the first search query. The one or more extracted words are associated with the search query as one or more attributes (i.e., extracted tags).

[0046] In one example regarding the use of dictionaries, the car dictionaries discussed earlier above are used in the following example rule:

Rule	Deliver	Intent	Query	Tags
InDictionary(2,"cars-make","cars-model","cars-year")	-	-	-	cars

This rule states that if a search query contains at least one word from each of at least two of the dictionaries listed (make+model, make+year, or model+year), then it is highly likely that the search query is about a specific car. For example, in the absence of any specific context the word “cherokee” might possibly refer to several different meanings. However, when accompanied by “jeep” or “2003”, the word “cherokee” almost always refers to a car model.

[0047] This particular rule only adds the “cars” tag, because the author of the rule determined that this is all that is that can be known from the conditions in that rule. However, multiple rules can apply or fire for any given query, and the attributes may sometimes overlap to form an automated, improved source of intelligence about the search queries.

[0048] Additional rules leveraging previously-applied rules may also be added to form a chain reaction of rules. As an example, consider the following:

Rule	Deliver	Intent	Query	Tags
InDictionary(2,"cars-make","cars-model","cars-year")	-	-	-	cars
HasTag("cars") AND InDictionary("words-fixing")	Y	Y	I	cars, problems, fixing

[0049] The second rule above states that if a query has already been given the tag “cars” and it also contains a word/phrase from the “words-fixing” dictionary, then the following characteristics are likely: the matching search query should be considered further by human editors as a potential title, the query is very likely to have intent, and the query expresses an informational goal.

[0050] In another example, the output for the search query, “1999 dodge intrepid 3.2 clicking sound when turn key”, would return the following metadata:

Deliverable	Y
Intent	Y
Tags	repairing; problems; specific; automotive
Extracted Tags	%ing sound%; 1999; Dodge; Intrepid
Rules Fired	InDictionary(2,"cars-make","cars-model","cars-year") AND ContainsPos("RB VB%","WRB") InDictionary(2,"cars-make","cars-model","cars-year") AND InDictionary("words-fixing") InDictionary(2,"cars-make","cars-model","cars-year")

The first rule listed in the “Rules Fired” section in the table above uses parts of speech combined with dictionary words and combinations as its criteria.

[0051] The various forms of metadata described above may be used, for example, in various ways. Some example uses are as follows:

1. Begin processing the search query as a title
2. Use tags to group this title with other titles that are also about, for example, one of the following:
 - a. Automotive
 - b. Problems
 - c. Repairing
 - d. Automotive + Problems
 - e. Automotive + Problems + Repairing
3. Use tags and extracted tags to group other titles together (e.g., in topic pages or automated recommendations)
 - a. All titles about Repairing + Dodge + Intrepid
 - b. All titles about Automotive + Problems + ___ing sounds
 - c. All titles about 1999 + Dodge + Intrepid

[0052] **Figures 4A-4B** show an exemplary list of attributes and their mappings to other attributes according to one embodiment. After applying the rules and associating tags to queries as described above, in some embodiments additional post-processing may be used. One form of post-processing that may be used is tag mapping, in which associated tags are mapped to new tag values. Such mapping may allow automatically shaping tags, such as for the following:

1. Consistency: Misspellings and spacing issues due to disparate work by multiple analysts may be corrected. For example, “cars”, “auto”, “autos”, and “automotive” all may be mapped to a single “automotive” tag.

2. Organization: Tags may be name-spaced with prefixes (e.g., “D-”, “T-”, etc.) to group like tags together into one or more categories. For example, all action tags like “fixing”, “making”, “installing”, etc., may be assigned a “D-” prefix indicating that these tags have something in common with each other (in this example, the D- tags are all action-based concepts). Prefix namespaces may also be used to create an ad-hoc hierarchy (e.g., “T-software” is a type of “TT-computers”). This ad-hoc hierarchy may be used, for example, to see or use a category (e.g., “computers”) after it has been broken down into more detail (e.g., “software” and “hardware”).

3. Hiding/Showing More Detail: Tags may be mapped to hide currently unnecessary details (i.e., detail not needed for an existing title selection process), but the detail may be retained as hidden associated tags and shown or used later if the need arises. For example, the tags “chemistry”, “biology” and “science fair” may all be mapped to a “Science” tag because no further tag is necessary in the existing process. In a later process, those tags can be reverse-mapped so that the higher-level, general “Science” tag is comprised of the now visible, science-specific tags.

[0053] **Figures 4A-4B** show a section of a tag-mapping table where tags in the left column get mapped to the tags in the right column. The word “contains” in the table indicates a correspondence, and this may be used for programmatic purposes (e.g., in a program to instruct a data processing system to look for instances of a particular word in the left column).

[0054] For example, the tag “age” is mapped, as shown in **Figure 4A**, to the new tag values “I-amounts” and “A-facts”. The tag “age” may have been used extensively throughout the plurality of rules, but rather than modifying each rule, tag-mapping may be used to change the tag attached to relevant queries in a separate step. As the table indicates, the “age” tag was modified to represent two different attributes of the matching queries: (i) an “amount” of something is likely being sought by the searcher; and (ii) those matching queries are seeking factual information.

[0055] As a specific example of the organization of attributes into categories, consider an action category and an item category. Attributes such as buying, using, fixing, identifying, and

creating may be organized into the action category. Attributes such as computers, pets, home, health, and sports may be grouped together since these attributes describe the topical nature of the query. Search queries may be selected based on the selection of an attribute from the action category and the selection of an attribute from the item category. The data processing system then may identify search queries having both of these attributes (and also other attributes). The set of identified search queries may be used for further processing and/or presented to a user on a display for manual review and/or initiating other action.

[0056] In one embodiment, the data processing system stores a first list of attributes in a first category, and the metadata includes a first attribute chosen from the first category. A second list of attributes may be stored in a second category, and the metadata may also include a second attribute chosen from the second category. The first category may correspond to intended actions and the second category may correspond to items.

[0057] In some embodiments, search queries may be sorted in numerous ways based on selected attributes and/or selected categories. For example, to assist in selecting a search query, the search queries may be sorted based on a combination of two or more attributes (e.g., a logical AND combination, or even more complicated logical combinations).

[0058] In yet other embodiments, rules may be chained so that the combination of two attributes leads to the addition of yet another attribute. For example, search queries previously submitted by users on other websites may be received. A first plurality of rules is applied to the search queries. The first plurality of rules includes a first rule, a second rule, and a third rule.

[0059] If a condition specified in the first rule exists in a first search query of the plurality of search queries, a first word is extracted from the first search query. If a condition specified in the second rule exists in the first search query, a second word is extracted from the first search query. Finally, if a condition that is dependent upon the first word and the second word, specified in the third rule exists in the first search query, an attribute is associated to the first search query. The associated attribute is used as part of the process of selecting one of the search queries (e.g., as a potential title for online content or as an online recommendation).

[0060] **Figures 5A-5B** show exemplary tags or attributes for search queries that are provided as output from the text string rules processing described above according to one embodiment. The illustrated tags are grouped using prefixes “a-”, “i-”, etc., as discussed above. The search queries may be used, for example, in further post-processing analysis (e.g., as discussed herein).

This analysis may be based, for example, on selections by a user of certain specific ones of these tags in order to present (e.g., on a display of a user terminal) various selections and organizations of search queries to the user (e.g., a user that is studying the search queries to discern useful patterns or correlations of information or to create additional rules for future use).

[0061] A specific, non-limiting example of the use of a set of rules to process search queries in one embodiment is now discussed below. A large number of unstructured search queries (e.g., tens to hundreds of millions or more) are received by a data processing system. Rules are applied to associate attributes to search queries as discussed above. Note that some search queries may not have any attribute associated if no rule is satisfied for the query.

[0062] Processing of the search queries is performed to assess the nature and type of the inquiries being made by the users that submitted the queries. This processing includes the following:

1. Disambiguate common words that could reasonably relate to multiple topics (e.g., *arm* as part of the body or *ARM* as a type of mortgage)
 - a. Use custom dictionary lists and accompanying rules to disambiguate the queries (e.g., if *arm* [*body part*] appears in the same query as *swelling* [*medical symptom*], then the word *arm* is very likely referring to a *body part*).
2. Using dictionary lists, text strings, parts of speech, word counts, and other conditions, use rules to infer at least one element of a search query and tag appropriately with one or more of the following:
 - a. Type of query, including but not limited to:
 - i. Query is a question
 - ii. Query expresses a problem
 - b. Goal of query, including but not limited to:
 - i. fact
 - ii. opinion
 - iii. instruction
 - c. Topic of query (e.g., sometimes one level deep, other times many levels down)
 - Health
 - Human

- Medical
 - Symptoms
 - *Swelling*
 - Body part
 - *Arm*

[0063] Next, certain search queries are selected as potential titles that could be turned into final content titles. For example, several thousand potential titles might be selected from millions of input search queries. Based on the associated tags and other characteristics, another layer of tags may also be associated with the search queries using rules that relate to the following aspects of a query:

1. Intent (e.g., *frozen strawberries* versus *freezing strawberries*)
 - a. The likelihood of a query being an information-based title, suitable for creating content around the query, may be assessed based on the following traits:
 - i. Individual words
 - ii. Text strings
 - iii. Placement of words or text strings in the query
 - iv. Part of speech strings
 - v. Placement of parts of speech strings in the query
2. Deliverability

Assess whether a potential title is likely to be consistent with predefined editorial standards and requirements (e.g., a policy manual provided to a contractor hired to review potential titles in order to select a final title).
3. Query type
 - a. Informational
 - b. Transactional
 - c. Navigational

Particular combinations of the above tags may be utilized as an additional indicator of the viability of a query to be used as part of a specific group of potential titles.

[0064] Selected search queries may next be transformed to prepare content titles. Many queries are similar and share common informational goals. Rules may be encoded for rewriting queries into more desirable forms.

[0065] In other embodiments, the metadata as discussed above may be used to assess how similar types of content perform (e.g., perform when used as a title) regardless of its topical attributes. For example, the performance of titles about “repairing” relative to “installing” may be assessed, or the performance of “advice”-based titles relative to fact-based titles may be assessed. The methods described above may be used to analyze this kind of information.

[0066] In other embodiments regarding related content, based on various tags, intelligence may be applied based on the tags to suggest related content to a user (e.g., to make recommendations regarding related content). For example, a user reading online published content about “How to Repair the Brake System in a 1993 Honda Accord” is likely not interested in reading about repairing brakes in any other car, but is more likely interested in other titles that share, for example, the following tags: “auto+repair+Honda+Accord”; or “Honda+Accord+brakes”.

[0067] In yet other embodiments, contextual and semantic metadata is automatically added to text strings (e.g., search queries, or groups of existing web page titles). A rule-based expert system parses text strings and looks for specific, predefined text patterns, parts of speech, words and word list combinations. These patterns may range from basic and explicit to complex and implicit, conditional patterns.

[0068] The rules are written as implied if/then statements; if a defined condition exists in a search query, for example one to a dozen or more attributes (and kinds of attributes) are added to that query as metadata. This metadata provides improved understanding of the search query (e.g., topic, search goal, search strategy and more may exist in the metadata, which may be further categorized by the kind of attributes the metadata represents).

[0069] In one embodiment, a software process may be used to analyze the resulting output metadata using combinations or permutations of the search query data and metadata. As a result, one is able to browse search queries by any or all of their associated attributes. This may allow finding other, different groups of desirable search queries, which may then be used to inform content strategy and production of content. This metadata and software process may also be used to find other, unobvious correlations in very large datasets of search queries or web page titles. This may go beyond topical categorization or other usually available data.

[0070] In alternative embodiments, the text strings to be processed may be existing titles that have already been used for published content. Further, one of these titles may be selected to be used as a recommendation or as related content (e.g., presented to a user visiting an informational or shopping website). The recommendation or related content may be provided to a user device that is accessing a website.

[0071] In other embodiments, the text strings to be processed are obtained from an existing online shopping website (e.g., text strings obtained from search queries or product purchase requests entered by a shopper on the website), and one of the text strings is selected to be used as a recommendation for a different online shopping website. The recommendation is provided to a user device of a user accessing the different shopping website.

[0072] **Figure 6** shows a block diagram of a data processing system which can be used in various embodiments to implement the application of rules to text strings as discussed above. While **Figure 6** illustrates various components of a computer system, it is not intended to represent any particular architecture or manner of interconnecting the components. Other systems that have fewer or more components may also be used.

[0073] In **Figure 6**, the system (201) includes an inter-connect (202) (e.g., bus and system core logic), which interconnects a microprocessor(s) (203) and memory (208). The microprocessor (203) is coupled to cache memory (204) in the example of **Figure 6**.

[0074] The inter-connect (202) interconnects the microprocessor(s) (203) and the memory (208) together and also interconnects them to a display controller and display device (207) and to peripheral devices such as input/output (I/O) devices (205) through an input/output controller(s) (206). Typical I/O devices include mice, keyboards, modems, network interfaces, printers, scanners, video cameras and other devices which are well known in the art.

[0075] The inter-connect (202) may include one or more buses connected to one another through various bridges, controllers and/or adapters. In one embodiment the I/O controller (206) includes a USB (Universal Serial Bus) adapter for controlling USB peripherals, and/or an IEEE-1394 bus adapter for controlling IEEE-1394 peripherals.

[0076] The memory (208) may include ROM (Read Only Memory), and volatile RAM (Random Access Memory) and non-volatile memory, such as hard drive, flash memory, etc.

[0077] Volatile RAM is typically implemented as dynamic RAM (DRAM) which requires power continually in order to refresh or maintain the data in the memory. Non-volatile memory

is typically a magnetic hard drive, a magnetic optical drive, or an optical drive (e.g., a DVD RAM), or other type of memory system which maintains data even after power is removed from the system. The non-volatile memory may also be a random access memory.

[0078] The non-volatile memory can be a local device coupled directly to the rest of the components in the data processing system. A non-volatile memory that is remote from the system, such as a network storage device coupled to the data processing system through a network interface such as a modem or Ethernet interface, can also be used.

[0079] In one embodiment, a data processing system as illustrated in **Figure 6** is used to implement one or more affiliated web sites. In other embodiments, the data processing system is used to store rules and apply them to text strings as described herein.

[0080] In another embodiment, a data processing system as illustrated in **Figure 6** is used to implement a user terminal, which may receive a search query from a user. A user terminal may be in the form of a personal digital assistant (PDA), a cellular phone, a notebook computer or a personal desktop computer.

[0081] In some embodiments, one or more servers of the system can be replaced with the service of a peer to peer network of a plurality of data processing systems, or a network of distributed computing systems. The peer to peer network, or a distributed computing system, can be collectively viewed as a server data processing system.

[0082] Embodiments of the disclosure can be implemented via the microprocessor(s) (203) and/or the memory (208). For example, the functionalities described can be partially implemented via hardware logic in the microprocessor(s) (203) and partially using the instructions stored in the memory (208). Some embodiments are implemented using the microprocessor(s) (203) without additional instructions stored in the memory (208). Some embodiments are implemented using the instructions stored in the memory (208) for execution by one or more general purpose microprocessor(s) (203). Thus, the disclosure is not limited to a specific configuration of hardware and/or software.

[0083] **Figure 7** shows a block diagram of a user device according to one embodiment. In **Figure 7**, the user device includes an inter-connect (221) connecting the presentation device (229), user input device (231), a processor (233), a memory (227), a position identification unit (225) and a communication device (223).

[0084] In **Figure 7**, the position identification unit (225) is used to identify a geographic location for user content sent to web site 123. The position identification unit (225) may include a satellite positioning system receiver, such as a Global Positioning System (GPS) receiver, to automatically identify the current position of the user device.

[0085] In **Figure 7**, the communication device (223) is configured to communicate with a web site or an online social network to provide user data or content. A response to a search query, or published content for viewing by a user, can be presented at least in part via the processor (233) and the presentation device (229).

[0086] In one embodiment, the user input device (231) is configured to generate user data content which is to be tagged with data provided by the user. The user input device (231) may include a text input device, a still image camera, a video camera, and/or a sound recorder, etc.

[0087] In this description, various functions and operations may be described as being performed by or caused by software code to simplify description. However, those skilled in the art will recognize what is meant by such expressions is that the functions result from execution of the code by a processor, such as a microprocessor. Alternatively, or in combination, the functions and operations can be implemented using special purpose circuitry, with or without software instructions, such as using an Application-Specific Integrated Circuit (ASIC) or a Field-Programmable Gate Array (FPGA). Embodiments can be implemented using hardwired circuitry without software instructions, or in combination with software instructions. Thus, the techniques are limited neither to any specific combination of hardware circuitry and software, nor to any particular source for the instructions executed by the data processing system.

[0088] While some embodiments can be implemented in fully functioning computers and computer systems, various embodiments are capable of being distributed as a computing product in a variety of forms and are capable of being applied regardless of the particular type of machine or computer-readable media used to actually effect the distribution.

[0089] At least some aspects disclosed can be embodied, at least in part, in software. That is, the techniques may be carried out in a computer system or other data processing system in response to its processor, such as a microprocessor, executing sequences of instructions contained in a memory, such as ROM, volatile RAM, non-volatile memory, cache or a remote storage device.

[0090] Routines executed to implement the embodiments may be implemented as part of an operating system, middleware, service delivery platform, SDK (Software Development Kit) component, web services, or other specific application, component, program, object, module or sequence of instructions referred to as “computer programs.” Invocation interfaces to these routines can be exposed to a software development community as an API (Application Programming Interface). The computer programs typically comprise one or more instructions set at various times in various memory and storage devices in a computer, and that, when read and executed by one or more processors in a computer, cause the computer to perform operations necessary to execute elements involving the various aspects.

[0091] A machine readable medium can be used to store software and data which when executed by a data processing system causes the system to perform various methods. The executable software and data may be stored in various places including for example ROM, volatile RAM, non-volatile memory and/or cache. Portions of this software and/or data may be stored in any one of these storage devices. Further, the data and instructions can be obtained from centralized servers or peer to peer networks. Different portions of the data and instructions can be obtained from different centralized servers and/or peer to peer networks at different times and in different communication sessions or in a same communication session. The data and instructions can be obtained in entirety prior to the execution of the applications. Alternatively, portions of the data and instructions can be obtained dynamically, just in time, when needed for execution. Thus, it is not required that the data and instructions be on a machine readable medium in entirety at a particular instance of time.

[0092] Examples of computer-readable media include but are not limited to recordable and non-recordable type media such as volatile and non-volatile memory devices, read only memory (ROM), random access memory (RAM), flash memory devices, floppy and other removable disks, magnetic disk storage media, optical storage media (e.g., Compact Disk Read-Only Memory (CD ROMS), Digital Versatile Disks (DVDs), etc.), among others.

[0093] In general, a machine readable medium includes any mechanism that provides (e.g., stores) information in a form accessible by a machine (e.g., a computer, network device, personal digital assistant, manufacturing tool, any device with a set of one or more processors, etc.).

[0094] In various embodiments, hardwired circuitry may be used in combination with software instructions to implement the techniques. Thus, the techniques are neither limited to

any specific combination of hardware circuitry and software nor to any particular source for the instructions executed by the data processing system.

[0095] Although some of the drawings illustrate a number of operations in a particular order, operations which are not order dependent may be reordered and other operations may be combined or broken out. While some reordering or other groupings are specifically mentioned, others will be apparent to those of ordinary skill in the art and so do not present an exhaustive list of alternatives. Moreover, it should be recognized that the stages could be implemented in hardware, firmware, software or any combination thereof.

[0096] In the foregoing specification, the disclosure has been described with reference to specific exemplary embodiments thereof. It will be evident that various modifications may be made thereto without departing from the broader spirit and scope as set forth in the following claims. The specification and drawings are, accordingly, to be regarded in an illustrative sense rather than a restrictive sense.

CLAIMS

What is claimed is:

1. A method, comprising:
receiving a plurality of text strings;
applying, via a data processing system, a first plurality of rules to the plurality of text strings;
if a condition specified in at least one of the rules exists in one of the respective text strings, associating at least one attribute to the one respective text string as metadata; and
automatically selecting, based on the metadata, one of the plurality of text strings.
2. The method of claim 1, wherein the selecting comprises automatically selecting one of the text strings as a potential title for corresponding content, and the method further comprises publishing the content, under a final title based on the potential title, in an electronic publication.
3. The method of claim 2, further comprising storing a first list of attributes in a first category, wherein the metadata further comprises a first attribute chosen from the first category.
4. The method of claim 3, further comprising storing a second list of attributes in a second category, wherein the metadata further comprises a second attribute chosen from the second category.
5. The method of claim 4, wherein the first category corresponds to intended actions and the second category corresponds to items.

6. The method of claim 1, further comprising prior to the selecting of the one text string, sorting the plurality of text strings based on a combination of two or more of the at least one attribute.
7. The method of claim 2, wherein the first plurality of rules comprises a first rule, and further comprising:
if a condition specified in the first rule exists in a first text string of the plurality of text strings, extracting one or more words from the first text string; and
associating the one or more extracted words to the first text string as one or more attributes for selecting the potential title.
8. The method of claim 1, further comprising prior to publishing the content, preparing the content to include one or more key words selected from the plurality of text strings.
9. The method of claim 1, further comprising prior to publishing the content, comparing the online monetization values of the potential title and at least one alternative title.
10. The method of claim 1, further comprising prior to publishing the content, transforming the potential title in preparation for use as a final title using a second plurality of rules.
11. The method of claim 10, wherein the second plurality of rules comprises at least one rule that associates a plurality of similar word variations with a single attribute.
12. The method of claim 1, wherein each respective text string is selected from one of the following text strings: a keyword phrase; a text string corresponding to an online search query previously received by a website; an existing title for published online content; and a text string obtained from an online shopping website.

13. The method of claim 1, wherein applying the first plurality of rules to the plurality of text strings comprises identifying one or more of the following: patterns in text strings, parts of speech, one or more specific words, and word combinations.
14. The method of claim 13, wherein identifying one or more specific words comprises identifying one or more words found in one or more dictionaries.
15. The method of claim 1, wherein the metadata comprises one or more of the following: at least one tag; an indication of intent; query type; and an indication of suitability for use as a title.
16. The method of claim 1, wherein the at least one attribute comprises a query type selected from one of the following types: informational, transactional, and navigational.
17. The method of claim 1, wherein the text strings are existing titles for published online content, and the selecting comprises selecting one of the text strings as a recommendation, and the method further comprises providing the recommendation to a user device.
18. The method of claim 1, wherein the text strings are obtained from a first online shopping website, and the selecting comprises selecting one of the text strings as a recommendation for a second online shopping website, and the method further comprises providing the recommendation to a user device of a user accessing the second shopping website.
19. A machine-readable media embodying instructions, the instructions causing a data processing system to perform a method, the method comprising:
receiving a plurality of search queries previously submitted by users on a plurality of websites;

applying, via the data processing system, a first plurality of rules to the plurality of search queries, wherein the first plurality of rules comprises a first rule, a second rule, and a third rule;

if a condition specified in the first rule exists in a first search query of the plurality of search queries, extracting a first word from the first search query;

if a condition specified in the second rule exists in the first search query, extracting a second word from the first search query;

if a condition, dependent upon the first word and the second word, specified in the third rule exists in the first search query, associating an attribute to the first search query; and

automatically selecting, based on the attribute, one of the plurality of search queries as a potential title for online content or as an online recommendation.

20. A method, comprising:

automatically receiving, via a data processing system, a plurality of search queries previously submitted by users on a plurality of websites, wherein the data processing system is communicatively coupled to receive a portion of the search queries from a respective server associated with each of the websites;

applying a first plurality of rules to the plurality of search queries, wherein the first plurality of rules comprises a first rule;

if a condition specified in the first rule exists in a first search query of the plurality of search queries, extracting one or more words from the first search query;

associating the one or more extracted words to the first search query as metadata;

automatically selecting, based on the metadata, one of the plurality of search queries as a potential title for corresponding content; and

publishing the content, under a final title based on the potential title, in an electronic publication.

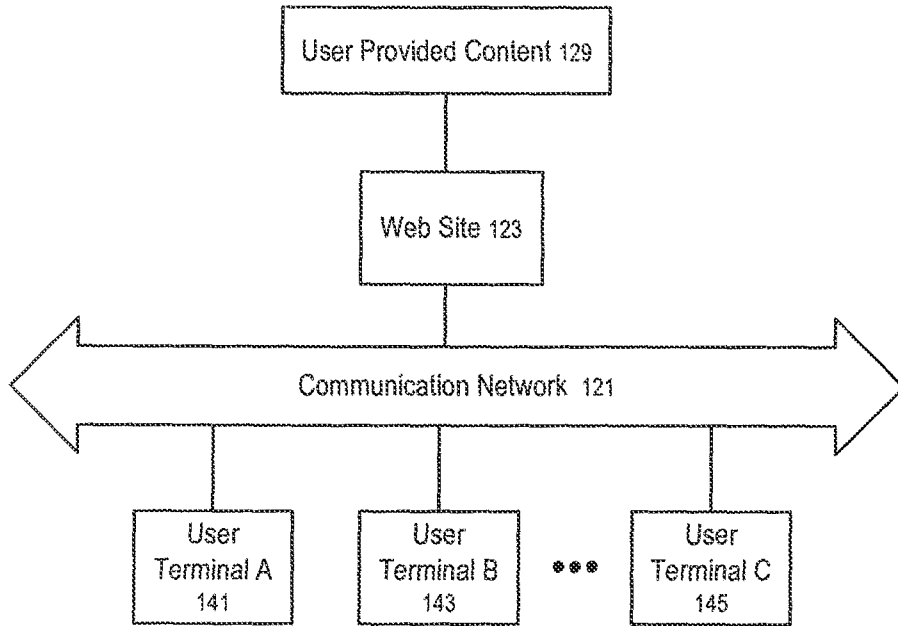

FIG. 1

Rule	Deliver	Intent	Query	Tags
Contains("plant nurser%") and InDictionary("all-geo")	N	Y		local,gardening,plants,yellowpages,shopping
InDictionary(2,"garden-plants","garden-modifiers") and NOT InDictionary("garden-bad","beauty-bodyparts")				outdoors,gardening
InDictionary(2,"garden-broad","garden-modifiers") and NOT InDictionary("garden-bad")				outdoors,gardening
InDictionary(2,"garden-broad","garden-plants") AND NOT InDictionary("garden-bad","med-bodyparts")				outdoors,gardening,plants
InDictionary(2,"garden-broad","garden-plants-latin") AND NOT InDictionary("garden-bad")				outdoors,gardening,plants
InDictionary(2,"garden-broad","garden-verbs") AND NOT InDictionary("garden-bad") AND NOT Contains("lawn care")				outdoors,gardening
InDictionary(2,"garden-features","garden-modifiers") AND NOT InDictionary("garden-bad")				outdoors,gardening
InDictionary(2,"garden-features","garden-verbs") AND NOT InDictionary("garden-bad")	Y	Y		outdoors,gardening
InDictionary(2,"garden-modifiers","garden-plants") AND NOT InDictionary("garden-bad","games-video")				outdoors,gardening,plants
InDictionary(2,"garden-modifiers","garden-plants-latin") AND NOT InDictionary("garden-bad","games-video")				outdoors,gardening,plants
InDictionary(2,"garden-plants-latin","garden-problems") AND NOT InDictionary("med-diseases","garden-bad")	Y	Y		outdoors,gardening,plants,problems,about
Contains(2,"leaf","identif%")	Y	Y		plants,identification,factsheet,informational,how-to
InDictionary(2,"garden-features","garden-plants") AND NOT InDictionary("garden-bad")				outdoors,gardening
InDictionary(2,"garden-features","garden-plants-latin") AND NOT InDictionary("garden-bad")				outdoors,gardening
In Dictionary(2,"garden-features","words-verb-ing")	Y	Y		gardening,outdoors,howto,informational
Contains("soil ph","soil requirements","in soil%","of	Y	Y		outdoors,about,factsheet,gardening

FIG. 2A

Rule	Deliver	Intent	Query	Tags
soil% "soils with") and NOT InDictionary("all-geo")	Y	Y		outdoors,about,factsheet
EndsWith("soils") and Contains("layers","ratio","stability","minerals")				outdoors,gardening
Contains("lawn care")	Y	Y		gardening,tips,strategy
Contains("secrets") and Contains("garden%","yard","landscaping")	Y	Y		gardening,tips,strategy,how-to
Contains("landscaping with","landscaping for","landscaping the","landscaping a") and NOT InDictionary("all-geo")				gardening
Contains("for gardens")	Y	Y		gardening,how-to,strategy
Contains("vegetable gardens") and StartsWithPos("VBG","W%")	Y	Y		flowers,gardening
Contains("flowers that","flowers which")	Y	Y		plants,gardening
Contains("plants that","plants which")	Y	Y		gardening,plants,about,factsheet
InDictionary("garden-plants-latin") and Contains("name","names","medical use%")	Y	Y		gardening,list
Contains("plant% list%")	Y	Y		gardening,plants,about,care
Contains(2,"grow%","aloe")	Y	Y		gardening,plants
InDictionary(2,"garden-verbs","garden-plants") AND NOT InDictionary(1,"all-geo","garden-bad")	Y	Y		animals,how-to,strategy
Contains("repel") and InDictionary("all-animals")				

FIG. 2B

	computers-hardware	exercise-muscles-bodyparts	garden-plants-latin
	computers-internet	finance-business-types	garden-problems
amounts-comp	computers-profiles	finance-general	garden-verbs
amounts-dist	computers-problems	finance-govt	geography
amounts-mass	computers-software	finance-issues	hobbies-general
amounts-power	computers-spam	finance-keywords	hobbies-music-instruments
amounts-prefix	computers-video	finance-people	home-action
amounts-volume	craft-types	finance-realestate	home-appliances
animals-about	culture-ethnic	finance-verb	home-appliances-startswith
animals-action	culture-general	finance-verb-ing	home-decor
animals-bugs	culture-holidays	fishing-action	home-electronics
animals-cats	culture-religion	fishing-fishnames	home-family
animals-dogs	culture-spirituality	fishing-gear	home-furniture
animals-list	diet-general	food-action	home-kitchen-brands
animals-pets-others	diet-names	food-adjectives	home-materials
animals-problems	education-action	food-alcohol	home-parts
animals-supplies	education-classactivities	food-alcohol-main	home-rules
astrology-signs	education-degrees-types	food-bad	home-styles
astrology-unambiguous	education-disorders	food-breads-starches	home-tools
babies-supplies	education-general	food-condiments	home-utensils
bad-golf	education-grades	food-dairy	jewelry-brands
beauty-bodyparts	education-issues	food-desserts	jewelry-cuts-settings
beauty-brands	education-people	food-drink	jewelry-gemstones-metals
beauty-conditions	education-schoolplaces	food-ethnic	jewelry-modifiers
beauty-people	education-school-types-pl	food-events	law-courts
beauty-places	education-school-types-sng	food-fruit	law-crimes
beauty-products	education-subjects	food-herbs-spices	law-general
beauty-spa-equipment	education-supplies	food-howto	law-judges
beauty-treatments	education-teacher-resources	food-list-general	law-juries
beauty-verb-ing	education-testing	food-meat	law-lawyers
beauty-verb-ing-startswith	electronics-cameras	food-nutrition	law-politics

FIG. 3A

beauty-verbs	electronics-cellphones	food-places	law-types
beauty-verbs-startswith	endswith-food-desserts	food-prepared	med-bodyfunctions
cars-characteristics	endswith-food-list-general	food-vegetables	med-bodyparts
cars-make	ent-awards	games-cards	med-diseases
cars-model	ent-movies	games-general	med-diseases-endswith
cars-parts	ent-music-types	games-puzzles	med-diseases-incurable
cars-types	ent-tv	games-video	med-doctors
cars-year	environment	games-video-hardware	med-drugs
clothing-general	exclusions	garden-bad	med-drugs-deliverytypes
clothing-jewelry	exercise-activity	garden-basics	med-modifiers
colors-basic	exercise-brands	garden-broad	med-procedures
computers-action	exercise-equipment	garden-equipment	med-procedures-endswith
computers-brands	exercise-general	garden-features	med-supplements
computers-dev	exercise-martial-arts	garden-modifiers	med-symptoms
computers-extensions	exercise-muscles	garden-plants	med-types

FIG. 3B

military-branches	places-us-nat-parks	words-adverbs
music-types	random-verbs	words-colors
names-actresses	restaurant-types	words-contractions
names-boys	retail-airlines	words-contractions-neg
names-domains	retail-fashion	words-dirty
names-girls	retail-general	words-emotions
outdoor-brands	retail-trains	words-ends-general
outdoor-disasters	science-space-entities	words-equipment
outdoor-entities	shopping	words-fixing
outdoor-for-outdoors	sports-awards	words-for
outdoor-gear	sports-bike-parts	words-foreign
outdoor-hazards	sports-common	words-ing-startswith
outdoor-people	sports-fishing-squip	words-intang-nouns
outdoors-not-trails	sports-fishing-fish	words-jobs
outdoor-trails-action	sports-golf-brands	words-junk
outdoor-verb	sports-golf-clubs	words-numbers-1-10
outdoor-verb-ing	sports-golf-courses	words-numbers-Greaterthan10
outdoor-verb-ing-startend	sports-golf-ecp	words-numbers-order
people-famous	sports-golf-related	words-personal
people-famous-endswith	sports-golf-verbs	words-preposition
people-golfers	sports-hunting	words-pronouns
people-jobs	sports-other	words-small
people-relationships	sports-teams	words-test
people-weddings	terms-realstate	words-that
pets-bad	test-damage	words-tips
pets-med-conditions	test-making	words-verb-ing
pets-med-drugs	test-testing	words-verb-phrases
phrasigroups-about	time-current	words-verbs
phrasigroups-advice	time-future	words-verbs-more
phrasigroups-amounts	time-holidays	words-verbs-startswith
phrasigroups-careers	time-units	yellowpages-mixed

FIG. 3C

phrasigroups-characteristics	time-years	yellowpages-places
phrasigroups-history	travel-bad	yellowpages-service
phrasigroups-how	travel-currencies	yellowpages-travel
phrasigroups-methods	travel-equipment	yellowpages-travel-sng
phrasigroups-questions	travel-fares	
phrasigroups-rules	travel-festivals	
phrasigroups-words	travel-hotelchains	
places-cities-us	travel-people	
places-cities-world	travel-peoples	
places-countries	travel-sights-indoors	
places-information	travel-sights-outdoors	
places-states	travel-sights-startswith	
places-tourist-us	travel-types	
places-tourist-world	travel-vehicles	
places-us-golf-locals	visuals	

FIG. 3D

a-advice	Contains	ll-advice
a-amounts	Contains	A-measurements
a-characteristics	Contains	AA-characteristics
a-factsheet	Contains	AA-factsheet
a-how-it-works	Contains	A-howitworks
a-how-to	Contains	DD-howto
a-reviews	Contains	ll-reviews
a-short-answer	Contains	AA-short_answer
a-strategy	Contains	DD-strategy
a-yes-no	Contains	AA-yes-no
aa-tips	Contains	DD-tips
abbreviations	Contains	AA-definition
about	Contains	AA-about,AA-factsheet
accommodations	Contains	executable, t-accommodations, TT-travel
accomodations	Contains	executable, t-accommodations, TT-travel
action	Contains	DD-action
activities	Contains	T-activities
activity	Contains	T-activities
address	Contains	Q-hyperlocal
adoption	Contains	T-adoption
advantages	Contains	l-pros_cons
advice	Contains	ll-advice
affect	Contains	l-effects
age	Contains	l-amounts, A-facts
air-travel	Contains	TT-travel
alcohol	Contains	TT-food, t-drinks
almanac	Contains	A-facts
alternatives	Contains	l-options, d-substituting
animals	Contains	TT-animals
amounts	Contains	l-amounts, A-facts, executable
analysis	Contains	AA-about
anatomy	Contains	T-body, AA-factsheet
animals	Contains	TT-animals
antiques	Contains	TT-hobbies
application	Contains	d-instructions, DD-strategy
apply	Contains	d-instructions, DD-strategy
art	Contains	T-art
astrology	Contains	TT-culture
attractions	Contains	T-places, TT-travel
automotive	Contains	TT-automotive
autumn	Contains	T-seasonal, Q-temporal
average	Contains	A-statistics
awards	Contains	T-awards
babies	Contains	T-babies, TT-family, t-kids
backgrounds	Contains	SET-visuals, TT-computers
bad	Contains	bad-delete
bankruptcy	Contains	TT-finance

FIG. 4A

9/12

basics	Contains	A-explanations,AA-about
battles	Contains	AA-history
beaches	Contains	TT-travel,T-attractions
beauty	Contains	t-beauty
becoming	Contains	d-becoming, AA-factsheet
before	Contains	AA-factsheet
beginners	Contains	DD-tips
behavior	Contains	I-behavior
benefits	Contains	I-pros_cons,AA-factsheet
best	Contains	I-ratings,I-superlatives
biography	Contains	A-biography, AA-history, T-people, AA-about
blanktodoblank	Contains	DD-strategy
blueprints	Contains	SET-visuals
body	Contains	T-body
brands	Contains	set-retail
breeds	Contains	T-breeds, TT-animals
budgeting	Contains	TT-finance
bugs	Contains	TT-animals, t-bugs
building	Contains	d-making
business	Contains	T-business
buy	Contains	SET-shopping,T-sales
buyers	Contains	SET-shopping,T-sales
cabins	Contains	executable, t-accommodations

FIG. 4B

<p>a-concepts (1) a-discoveries (4) a-equipment (1) a-eras (1) a-examples (1) a-explanations (51) a-facts (1828) a-famous (1) a-howitworks (13) a-names (5) a-resources (3) a-rules (5) a-similarities (3) a-stages (4) a-statistics (3) a-symptoms (1567) a-types (13)</p>	<p>i-amounts (41) i-behavior (1) i-choosing (40) i-comparison (28) i-complications (2) i-dangers (6) i-effects (614) i-guides (1) i-advice (385) ii-decisions (37) ii-reviews (27) i-laws (2) i-needs (1) i-opinions (9) i-options (4) i-prevention (8) i-problems (145) i-pros_cons (6) i-ratings (5) i-safety (6) i-solutions (1) i-superlatives (29)</p>	<p>aa-about (2263) aa-characteristics (261) aa-factsheet (2488) aa-history (10) aa-list (81) aa-questions (197) aa-short_answer (98) aa-yes-no (55)</p>	<p>d-becoming (8) d-caring (94) dd-action (3) dd-howto (78) dd-strategy (132) dd-tips (16) d-finding (20) d-fixing (182) d-instructions (5) d-making (23) d-methods (224) d-recipes (2) d-removing (5) d-substituting (4) d-testing (6) d-treating (147)</p>	<p>f-advice (17) f-factsheet (263) f-how to (4) f-howto (48) f-how-to (1) f-list (407) f-opinion (3) f-other (1) f-process (16) f-review (1) f-shopping-review (1) f-strategy-problems (194) f-strategy/tip (1) f-tip (327) f-tips (3)</p>
<p>t-teams (4) t-activities (7) t-babies (15) t-beauty (211) t-body (674) t-bugs (13) t-cats (29) t-diets (21) t-doctors (8) t-dogs (75) t-exercise (6) t-fashion (1)</p>	<p>ft-animals (151) ft-careers (3) ft-clothing (1) ft-computers (6) ft-culture (3) ft-education (30) ft-entertainment (2) ft-family (20) ft-finance (5) ft-fitness (10) ft-food (75) ft-gardening (23)</p>			

FIG. 5A

<p>t-golf (1) t-herbs (11) t-insurance (1) t-internet (1) t-kids (20) t-med_treatments (3024) t-medical (3030) t-men (12) t-military (1) t-movies (2) t-nutrition (110) t-people (101) t-pets (138) t-places (1) t-plants (34) t-pregnancy (120) t-products (3) t-relationships (205) t-science (4) t-services (41) t-supplements (139) t-trails (1) t-training (1) t-video (2) t-women (161) t-words (1)</p>	<p>tt-geography (1) tt-hobbies (2) tt-home (4) tt-outdoors (25)</p>
---	--

FIG. 5B

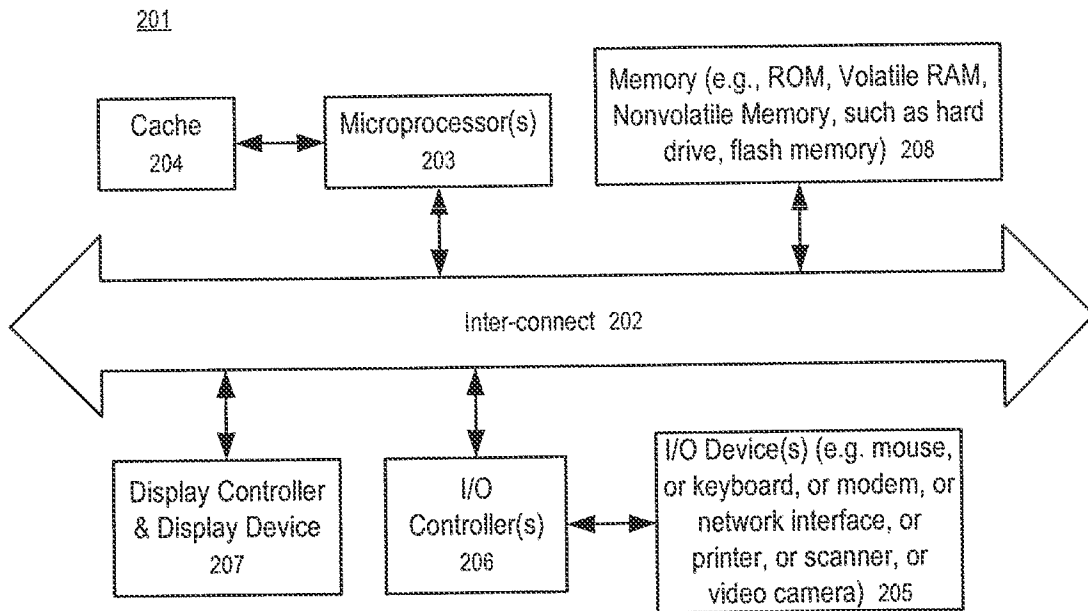

FIG. 6

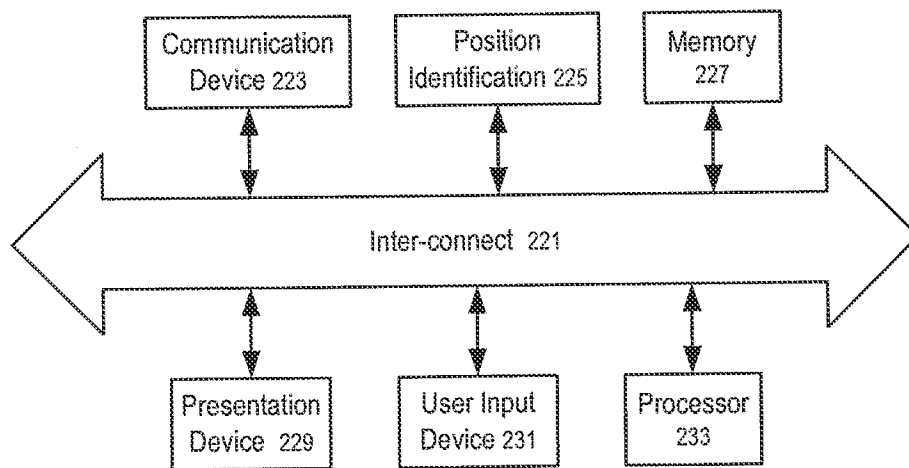

FIG. 7