

No. 679,256.

Patented July 23, 1901.

T. C. EDWARDS.
SAD IRON.

(Application filed Mar. 23, 1899.)

(No Model.)

2 Sheets—Sheet 1.

Fig. 1.

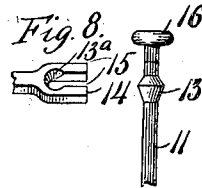
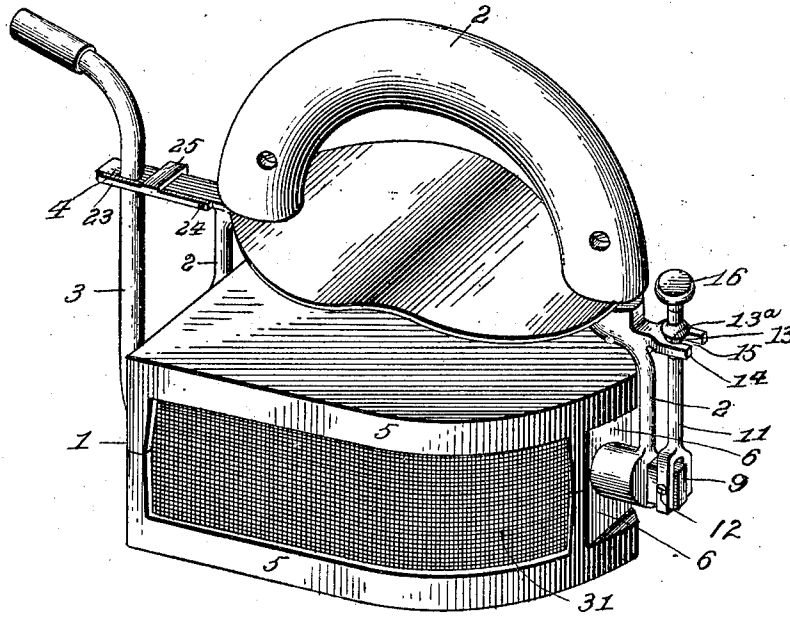
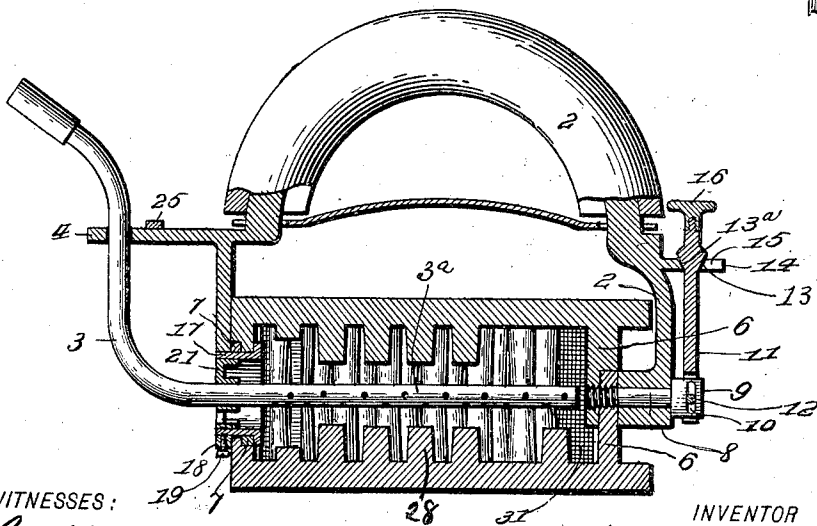

Fig. 2.



WITNESSES:

Robert Bradley
Harry A. Knight

INVENTOR

Thomas C. Edwards.

BY

Knight & Co.
ATTORNEYS.

T. C. EDWARDS.
SAD IRON.

(Application filed Mar. 23, 1899.)

(No Model.)

2 Sheets—Sheet 2.

Fig. 3.

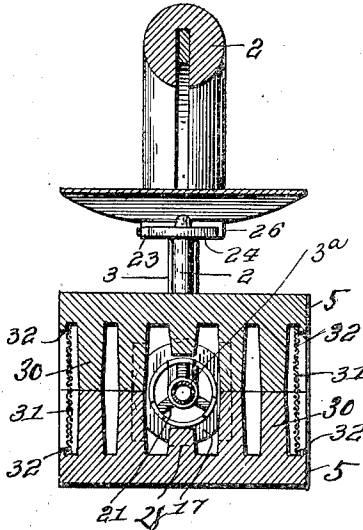

Fig. 4.

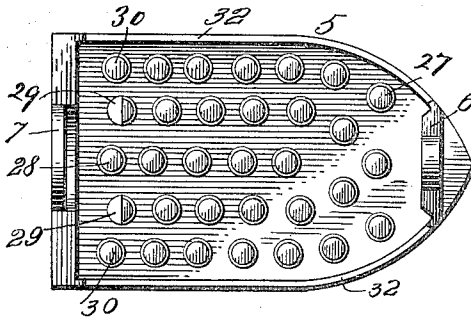

Fig. 5.

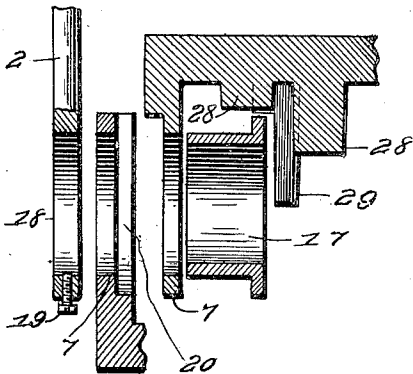

Fig. 6.

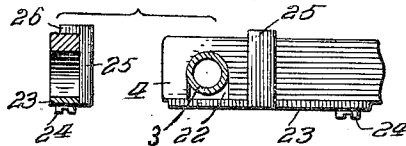
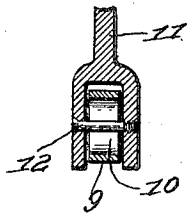

Fig. 7.



WITNESSES:

Herbert Bradley
Harry A Knight

INVENTOR

Thomas C. Edwards

BY

Knights Bros
ATTORNEYS.

UNITED STATES PATENT OFFICE.

THOMAS C. EDWARDS, OF PHILADELPHIA, PENNSYLVANIA.

SAD-IRON.

SPECIFICATION forming part of Letters Patent No. 679,256, dated July 23, 1901.

Application filed March 23, 1899. Serial No. 710,211. (No model.)

To all whom it may concern:

Be it known that I, THOMAS C. EDWARDS, a citizen of the United States, and a resident of Philadelphia, in the State of Pennsylvania, have invented certain new and useful Improvements in Sad-Irons, of which the following is a specification.

My invention relates to self-heating reversible sad-irons, and has for its object to so construct the several parts of such an implement that it will be rendered cheaper and more durable in construction and more convenient and effective in use.

My invention is an improvement on the self-heating sad-iron described, shown, and claimed in my application filed August 25, 1898, Serial No. 689,475.

My invention consists in certain novel features of construction, hereinafter fully described, and particularly pointed out in the claims, reference being had to the accompanying drawings, in which—

Figure 1 is a perspective view of a sad-iron embodying the features of my invention.

Fig. 2 is a vertical longitudinal section of the same. Fig. 3 is a vertical transverse section.

Fig. 4 is a plan view of one of the sections of the body portion or iron proper. Fig. 5 represents the segregated parts by means of which

the rear ends of the iron-sections are secured together and trunnioned in the handle. Fig. 6 is a detail view illustrating the means for holding the burner-tube in the handle and permitting its ready removal therefrom. Fig. 7 is a detail view showing the connection of the reversing-lever with the trunnion-screw of the iron. Fig. 8 is a detail perspective view showing the connection between the reversing-lever and the hanger, the parts being

disconnected.

1 represents the body of the iron, 2 a handle in which the iron is trunnioned to make it reversible, and 3 a burner-tube which enters the rear end of the iron and is held by a suitable bracket 4, projecting from the handle 2.

The body portion 1 consists of two similarly-constructed body-sections 5, having at their front and rear ends overlapping ears 6

7, respectively. As shown in Fig. 2, a screw 8 passes through the front ears 6 and forms a trunnion for one end of the handle 2. The

screw 8 is provided with an enlarged and vertically-elongated head 9, formed with a slot 10 to provide a mounting for a reversing-lever 11, which is bifurcated, as shown in Fig. 7, and secured by a screw-pin 12, so as to be vertically and outwardly movable upon the screw-head, but not transversely movable relatively thereto. The upper end of the reversing-lever 11 has a tapered enlargement 13, which rests in a correspondingly-formed socket 13^a of a hanger 14, which socket communicates with an outwardly-opening slot 15. The reversing-lever 11 terminates in a knob or handle 16, by which it may be lifted until a reduced portion of its length comes opposite the slot 15, when it is readily swung outward and released from the hanger, so that it may be moved laterally to reverse the iron. The rear ends of the sections are held together by means of a thimble 17, which passes outward through enlarged openings in the ears 7 and projects sufficiently beyond the same to form a trunnion, which enters the ring 18 on the rear end of the handle 2. The ring 18 is secured to the protruding end of the thimble 17 by means of a set-screw 19 and the parts thus locked securely in position. The rear ears 7 are halved together in such a manner that the outer ear provides a seat 20 for the inner ear 7, and by this means the parts are centered or fixed against lateral displacement, and a very much more rigid connection is provided. The thimble 17 is of sufficient size to receive the spider 21, which supports the burner 3^a within the iron and preserves sufficient space around it to permit the passage of the proper quantity of air from the rear.

The burner-tube 3 fits in a slot 22 in the bracket 4 and is secured therein by means of a latch 23, which is pivoted at 24 to swing in a vertical plane and provided with a cross-bar 25, which rests upon the bracket to hold the latch 23 across the mouth of the slot. The latch is strengthened against outward displacement by means of a projection 26 on the bar 25, which engages behind the bracket, as shown in Fig. 6.

The sections of the iron are of peculiar interior construction. The inner surface of each is covered by a number of round projections 27, arranged in rows or series and

suitably spaced apart to divide up the interior of the iron into a number of circuitous air-passages. The central row of projections 28 are terminated short of the dividing-plane of the iron for the purpose of leaving room for the burner 3^a; but the two outer series 29 and 30 on either side are extended to the dividing-plane between the sections, and the ends of the corresponding projections from the two sections meet, as shown in Fig. 3. The object of so constructing the iron is to provide, as stated, a number of circuitous air-passages in which the gases will become thoroughly mixed with the air, while the projections receive impingement of the burning gases and insure rapid and continuous conduction of the heat to the working surfaces. The sections of the iron are spaced apart by the ears 6 and 7, as well as by the projections 29 and 30. This leaves the sides of the iron open. For the purpose of dividing up the inflow of air for the support of combustion and confining the flame within the iron the sides of the iron are covered by wire-cloth 31, for the confinement of which the sections of the iron are provided with vertical flanges 32. (See Fig. 3.)

An iron constructed as above described will insure perfect combustion of the fuel which is discharged through jet-openings in the burner-tube and the heating effect will be rapid. Moreover, the meeting of the projections 29 and 30 will insure conduction of heat from the upper to the lower section and keep the latter to a working temperature for a longer period.

Having thus described my invention, the following is what I claim as new therein and desire to secure by Letters Patent:

1. In a sad-iron, the combination with a sectional body, the sections of which have overlapping lips, of handle-brackets carrying bearings which pass through said overlapping lips thus locking the sections of the body together and locking the handle to the body.

2. In a sad-iron the combination with a sectional body, the sections of which have overlapping lips, of a handle the arms or brackets of which carry bearings passing through openings in said lips and a device for locking the handle against movement.

3. In a sad-iron, the combination with a sectional body, each section having overlapping lips, of a handle the arms or brackets of which have bearings passing through openings in said overlapping lips, and a removable burner-pipe passing through one of said bearings.

4. In a self-heating sad-iron, the combination of the sections of the body portion provided with overlapping ears, the flanged thimble inserted in said ears and protruding beyond the same to form a trunnion, and the handle having a ring fitting upon the protruding end of said thimble; substantially as herein explained.

5. In a reversible sad-iron, the combination of the sections of the body portion having overlapped ears provided with coinciding openings and means passing through said openings of the ears to hold the sections of the iron together; said ears being vertically halved together, and one of them being provided with a seat in which the other rests, for the purpose of securing the sections of the iron against lateral displacement; substantially as herein explained.

6. In a self-heating sad-iron, the combination of the sections of the body portion having overlapping ears, the thimble passing through said ears and provided with a flange engaging on one side thereof, and the handle provided with a ring fitting upon a protruding end of the thimble and having a set-screw which impinges the thimble to hold the parts in position; substantially as herein explained.

7. In a reversible sad-iron, the combination of the body portion provided with overlapping ears, a trunnion-screw, whereby the ears are connected, a handle pivoted to the trunnion-screw, a reversing-lever having slot-and-pin connection with said trunnion-screw, and means for holding the reversing-lever against movement; substantially as herein explained.

8. In a reversible sad-iron, the combination of the body portion provided with overlapping ears, a trunnion-screw, whereby the ears are connected, a suitable handle in which said body portion is trunnioned, a reversing-lever having slot-and-pin connection with the trunnion-screw, and a hanger on the handle with which the reversing-lever engages by the movement permitted by its slot-and-pin connection; substantially as herein explained.

9. In a reversible sad-iron, the combination of the trunnioned body portion, having overlapping ears at each end and a suitable handle, a trunnion-screw, a reversing-lever movable in the plane of the trunnion-screw, but fixed against movement transversely thereto, and the slotted hanger in which said reversing-lever engages; substantially as herein explained.

10. In a reversible sad-iron, the combination of the body portion provided with a suitable trunnion, a handle in which said body portion is trunnioned, a reversing-lever movable relatively to the trunnion in the plane of said trunnion, but not transversely thereto, and provided with an enlargement, and a hanger for said reversing-lever provided with a socket in which the enlargement fits, and with a reduced slot through which the reversing-lever may be removed from the hanger by withdrawing the enlargement from the socket; substantially as herein explained.

11. In combination with a self-heating sad-iron, a burner-tube removably mounted in said iron, and a slotted bracket in which said burner-tube fits, provided with a latch projecting across the opening of the slot, mounted upon a suitable pivot and having the cross-

bar which rests upon the bracket to limit the movement of the latch; substantially as herein explained.

5 12. A self-heating sad-iron comprising a suitable handle and a body portion formed by two similarly-constructed hollow sections provided on their interior with outer, inner, and intermediate series of rounded projec-

tions dividing the interior of the iron into a number of circuitous air-passages and at their ends with overlapping ears; substantially in the manner and for the purposes set forth. 10

THOMAS C. EDWARDS.

Witnesses:

RODMAN L. BETTS,
CLAYTON W. PEIRSON.