



(19) **United States**

(12) **Patent Application Publication**

Lee et al.

(10) **Pub. No.: US 2006/0118274 A1**

(43) **Pub. Date: Jun. 8, 2006**

(54) **HEAT EXCHANGE UNIT INCLUDING APPARATUS TO REMOVE CONDENSED WATER**

(75) Inventors: **Kang-young Lee**, Chungcheongnam-do (KR); **Young-Ho Kim**, Osan-city (KR)

Correspondence Address:  
**SUGHRUE MION, PLLC**  
2100 PENNSYLVANIA AVENUE, N.W.  
SUITE 800  
WASHINGTON, DC 20037 (US)

(73) Assignee: **EC TECH CO., LTD.**

(21) Appl. No.: **10/525,336**

(22) PCT Filed: **Aug. 21, 2003**

(86) PCT No.: **PCT/KR03/01685**

(30) **Foreign Application Priority Data**

Aug. 22, 2002 (KR) ..... 20-2002-0025022  
Oct. 22, 2002 (KR) ..... 10-2002-0064454  
Jul. 4, 2003 (KR) ..... 20-203-0021476

**Publication Classification**

(51) **Int. Cl.**  
**F25B 29/00** (2006.01)  
(52) **U.S. Cl.** ..... **165/58**

(57) **ABSTRACT**

Disclosed is a heat exchange unit including an apparatus to remove condensed water by allowing the condensed water gathered on a cooling fin part of the heat exchange unit to be evaporated to the air within the heat exchange unit itself. According to the present invention, there is provided a heat exchange unit having a hot sink equipped with a heat discharging fan, a cool sink equipped with a cooling fan and a thermoelectric element disposed between the hot sink and the cool sink, and a condensed water-evaporating means for absorbing the condensed water gathered in the cool sink provided within the heat exchange unit and evaporating the condensed water to the air by the heat of the hot sink. The heat exchange unit according to the present invention is available for evaporating the condensed water therein, and thus, neither condensed water reservoir nor a discharging hose is separately needed, thereby reducing the production and installation costs. Also, since the condensed water is evaporated by the heat generated within the hot sink of the heat exchange unit, there is no additional energy to evaporate the condensed water.

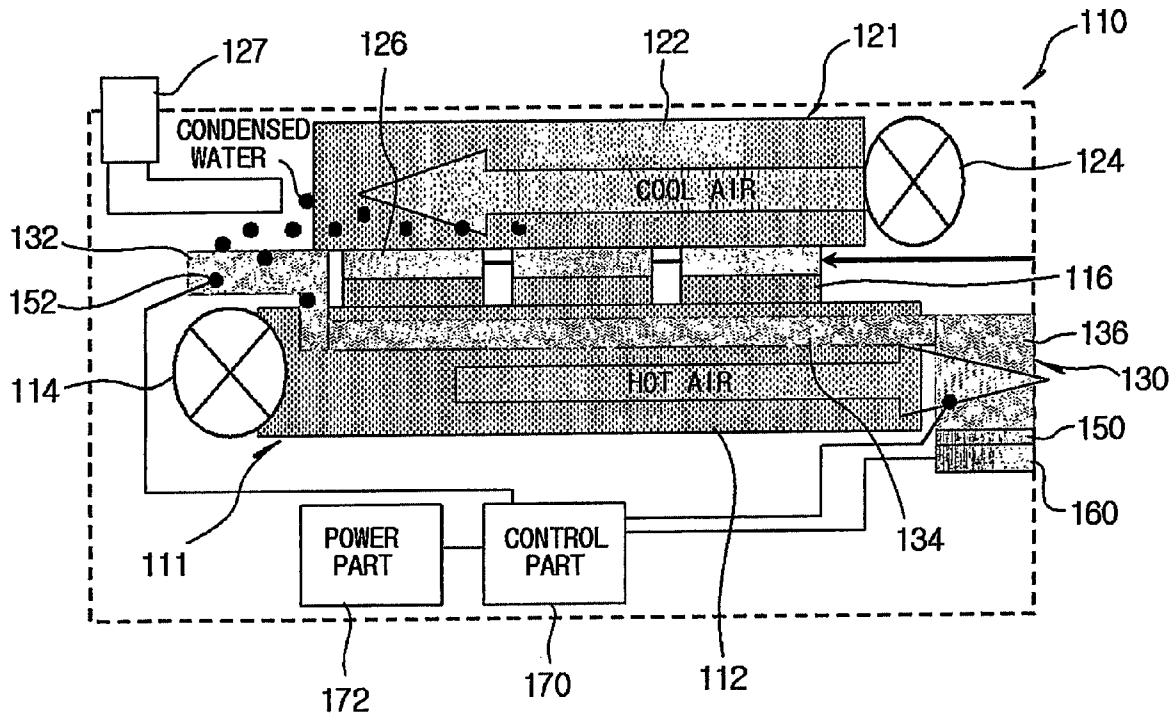

FIG. 1

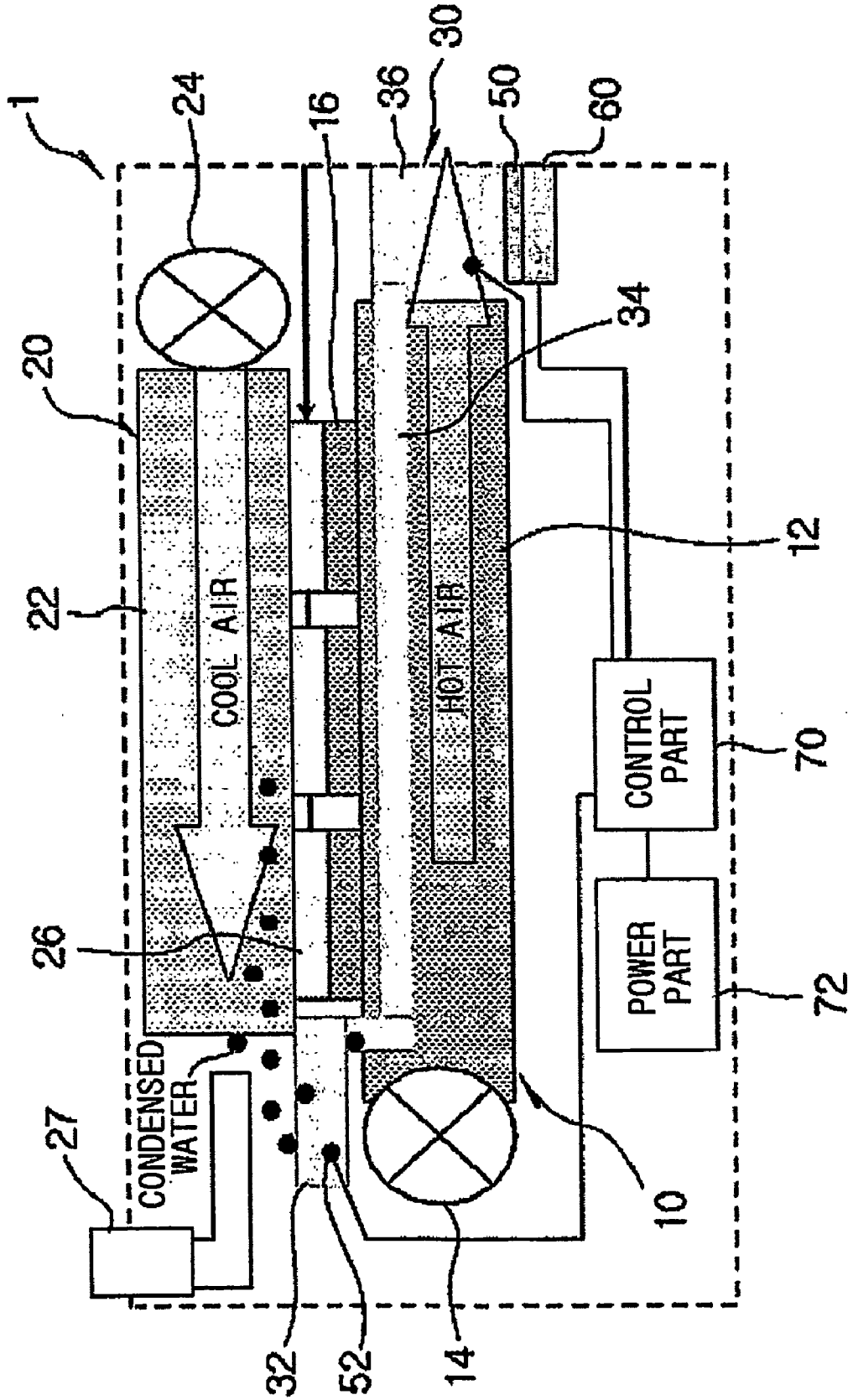

FIG. 2

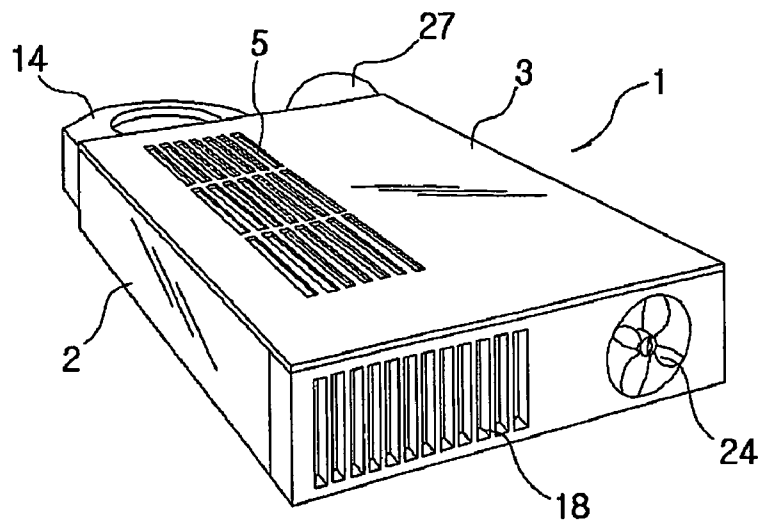

FIG. 3

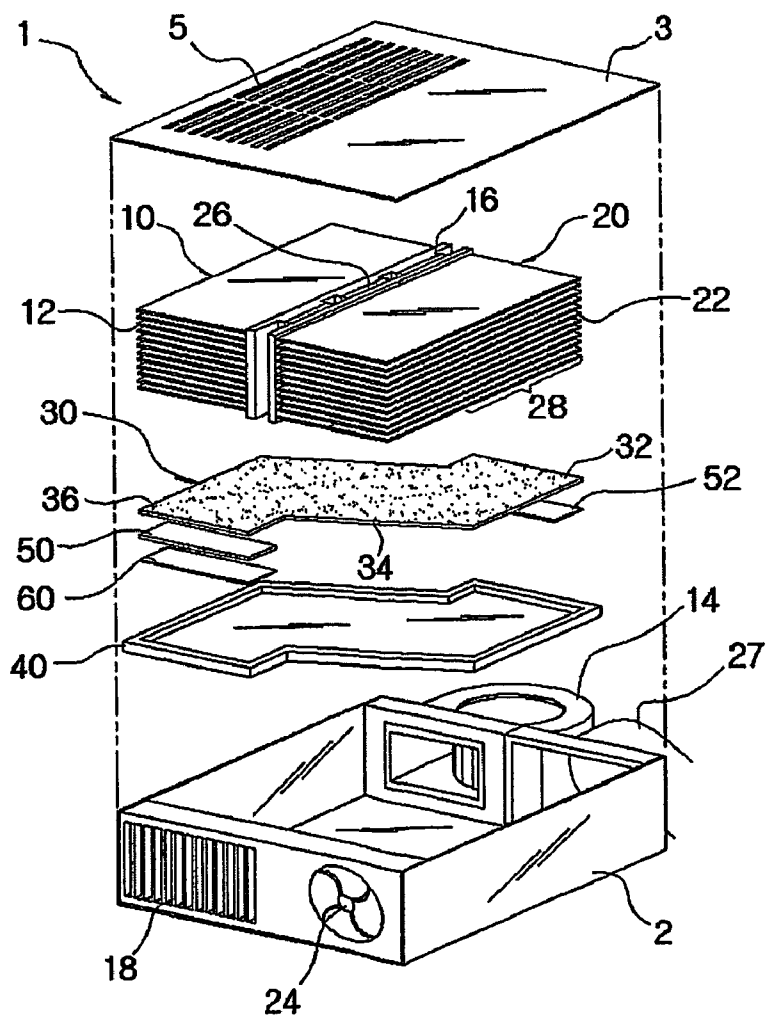

FIG. 4

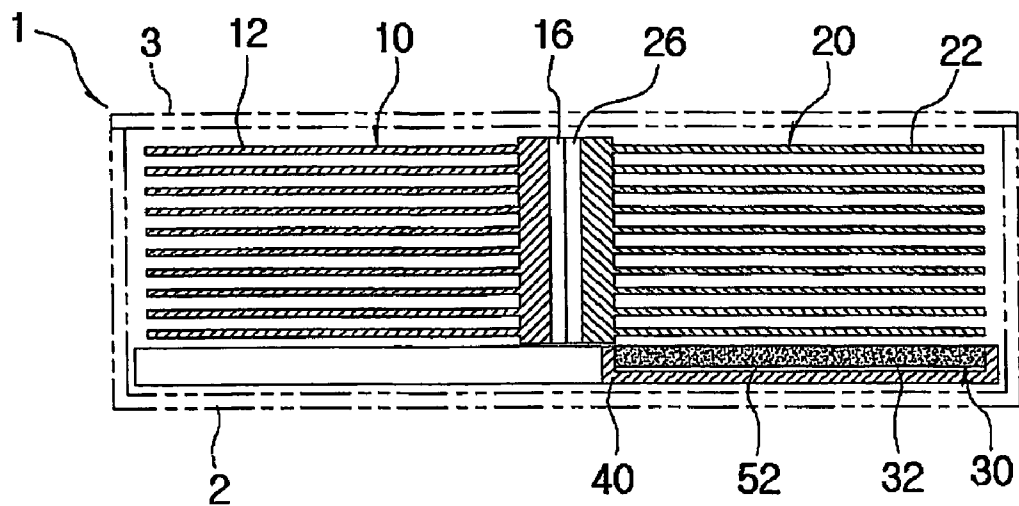

FIG. 5

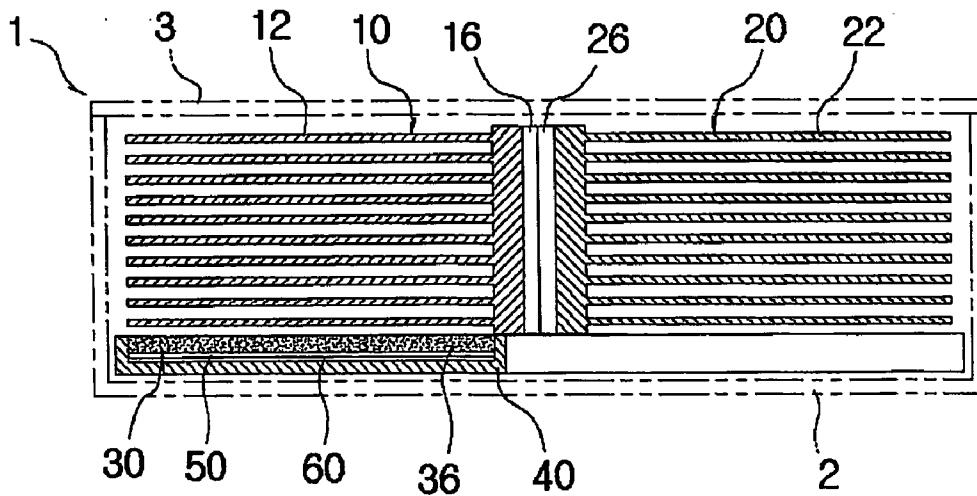

FIG. 6

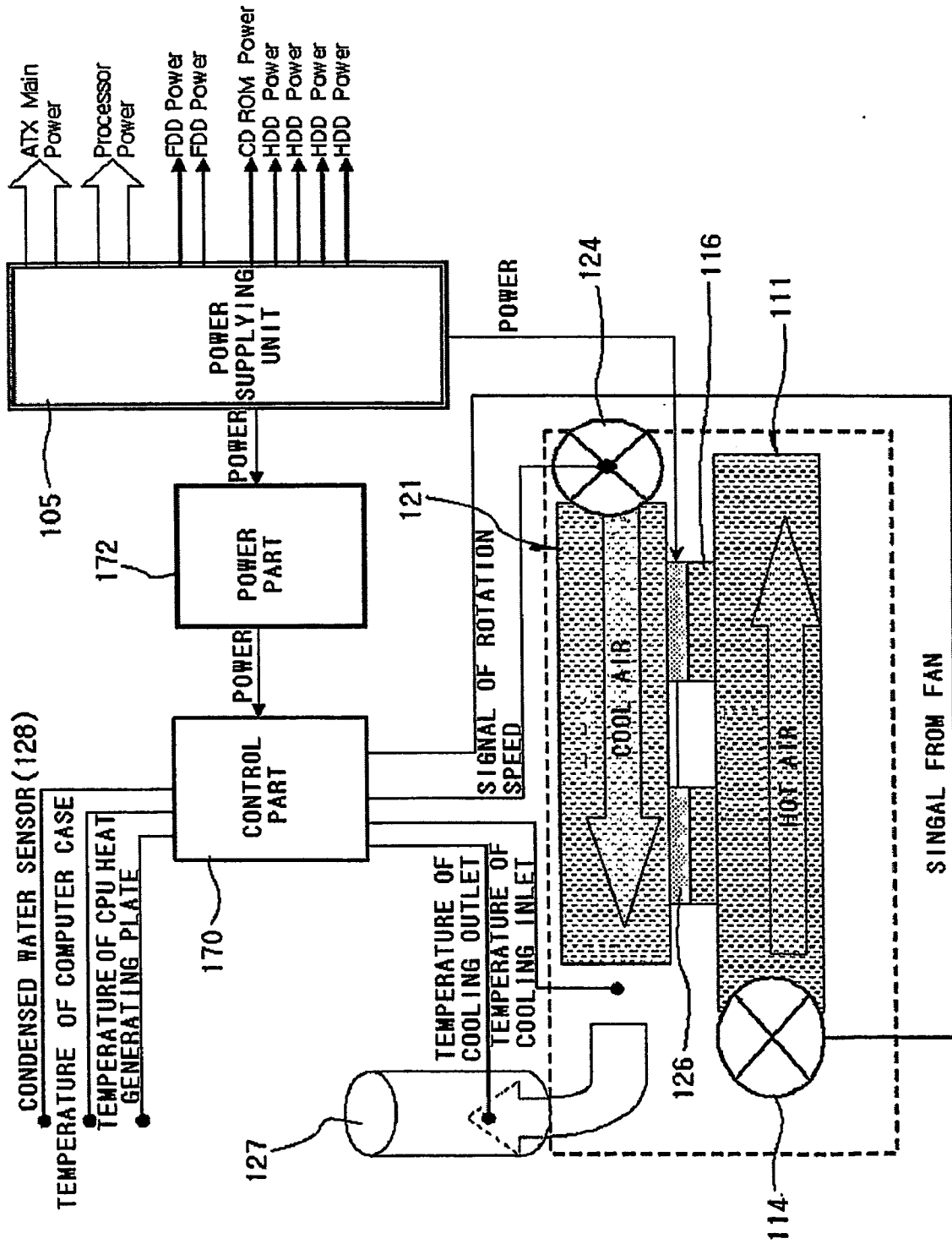

FIG. 7

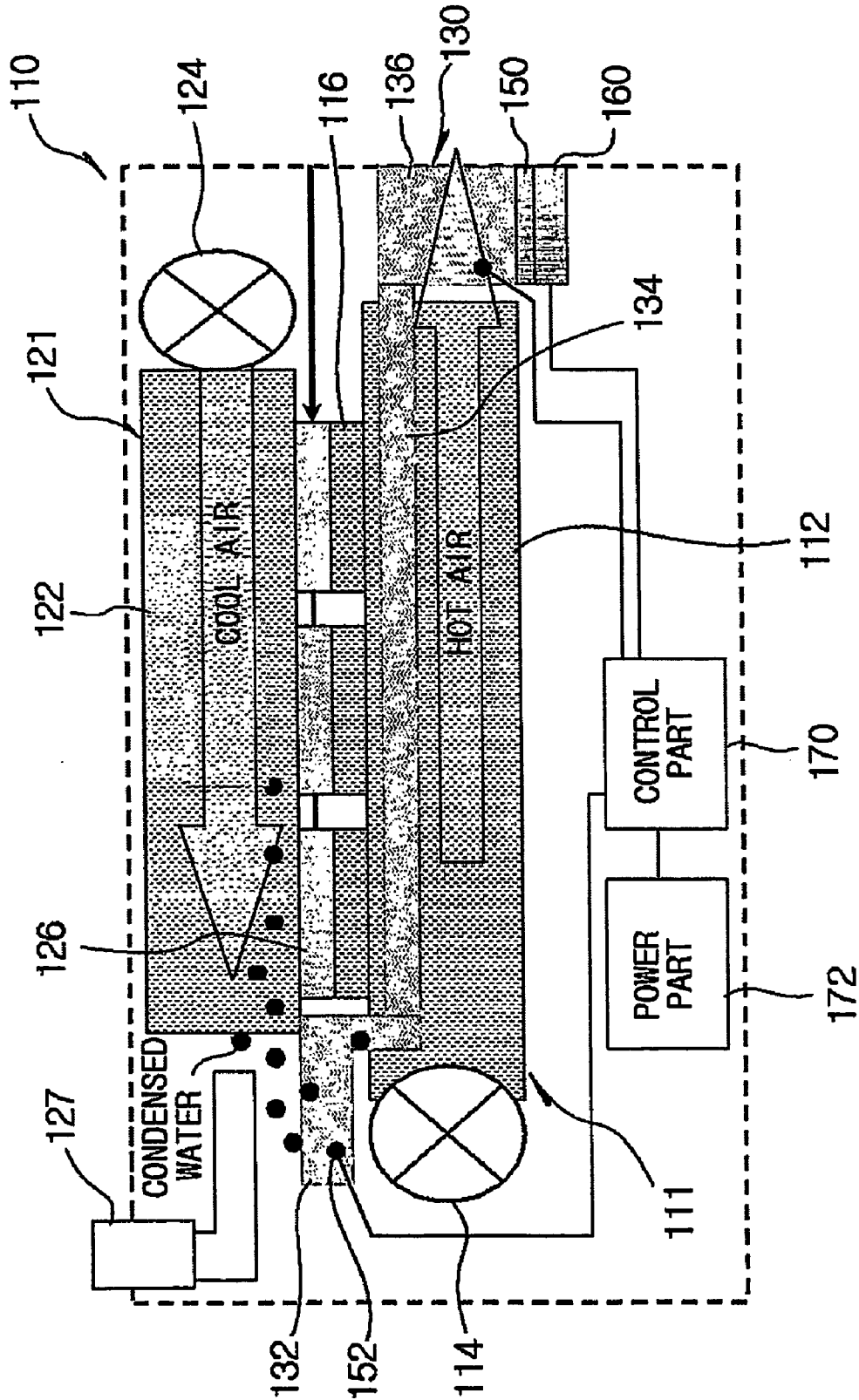

FIG. 8

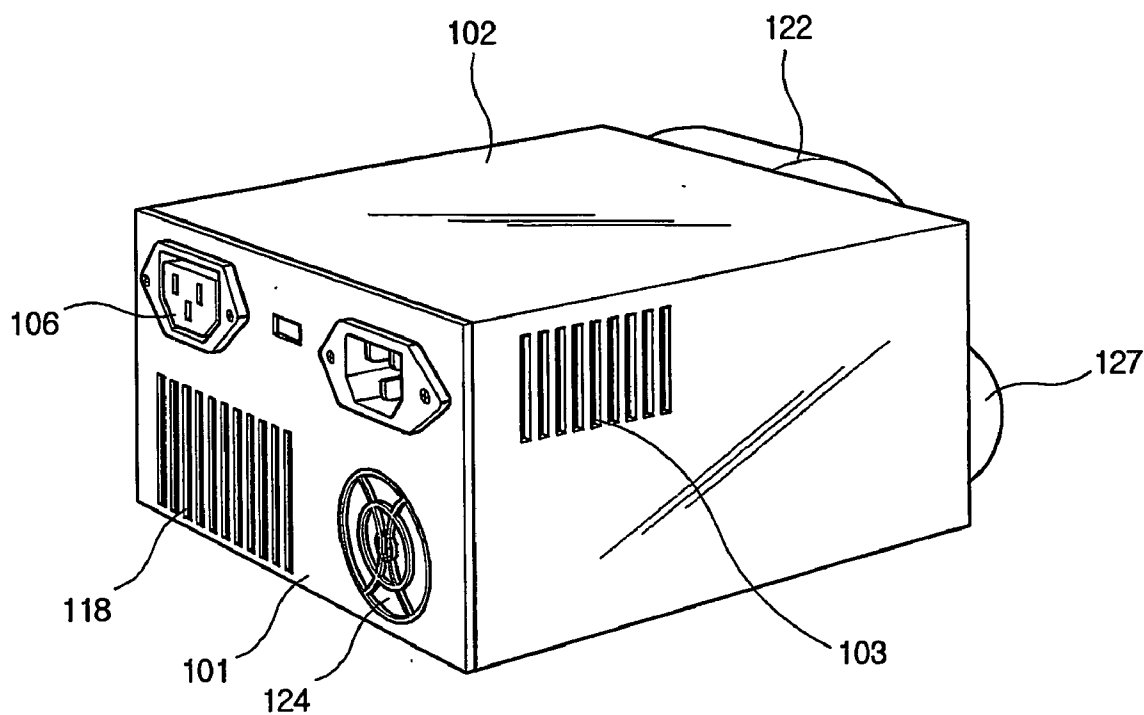

FIG. 9

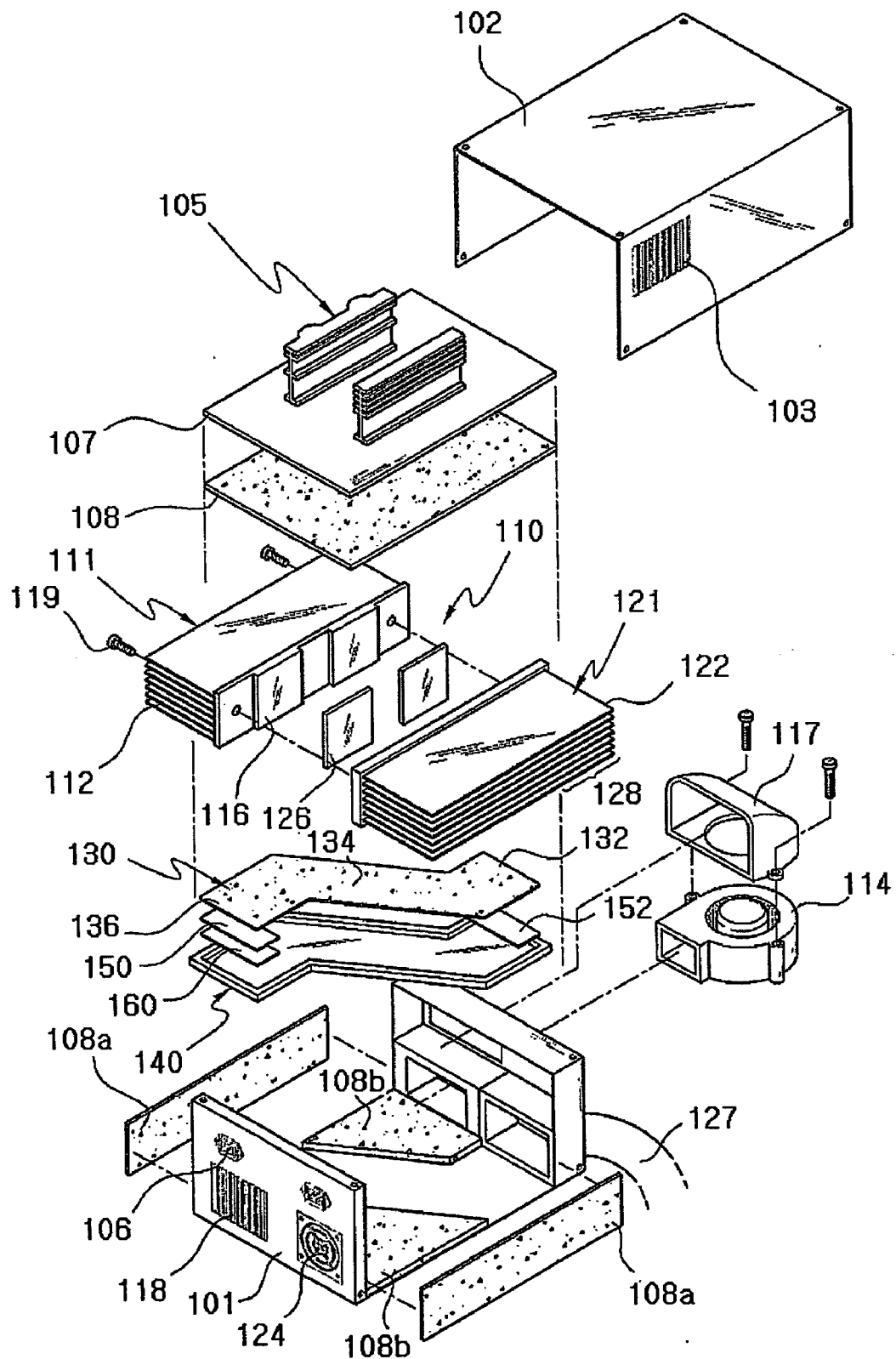



FIG. 10

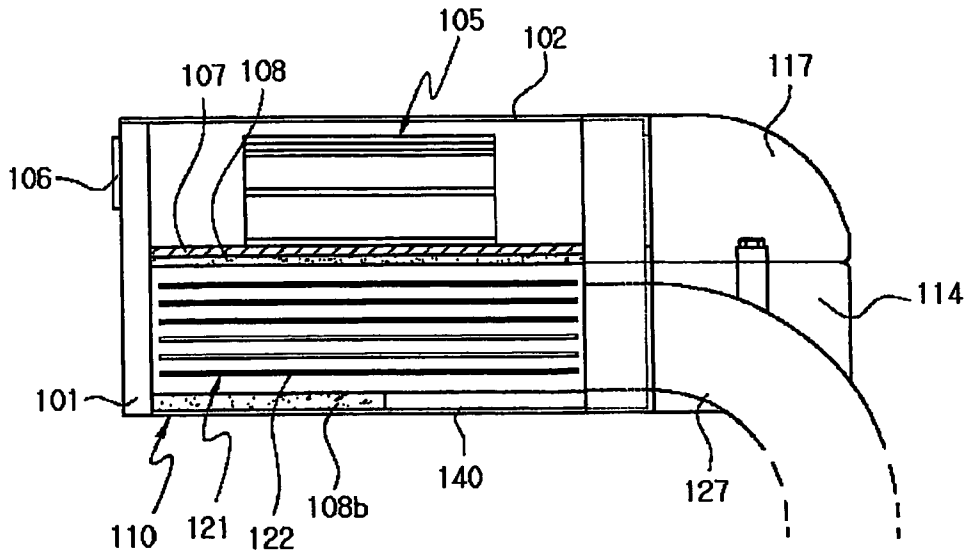

FIG. 11

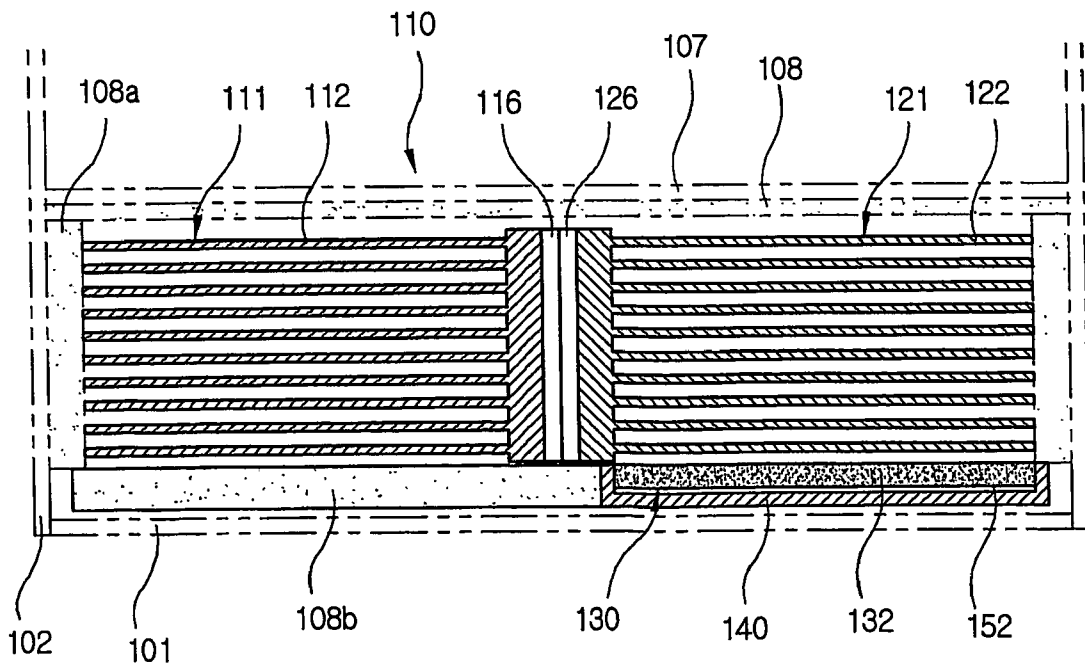

FIG. 12

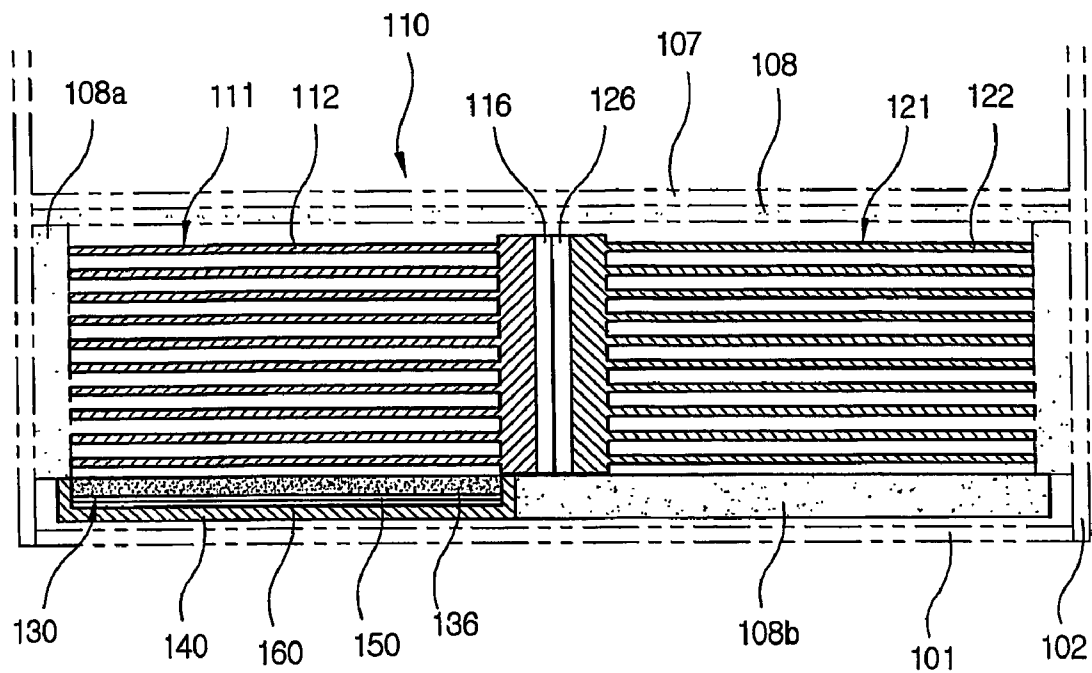

FIG. 13

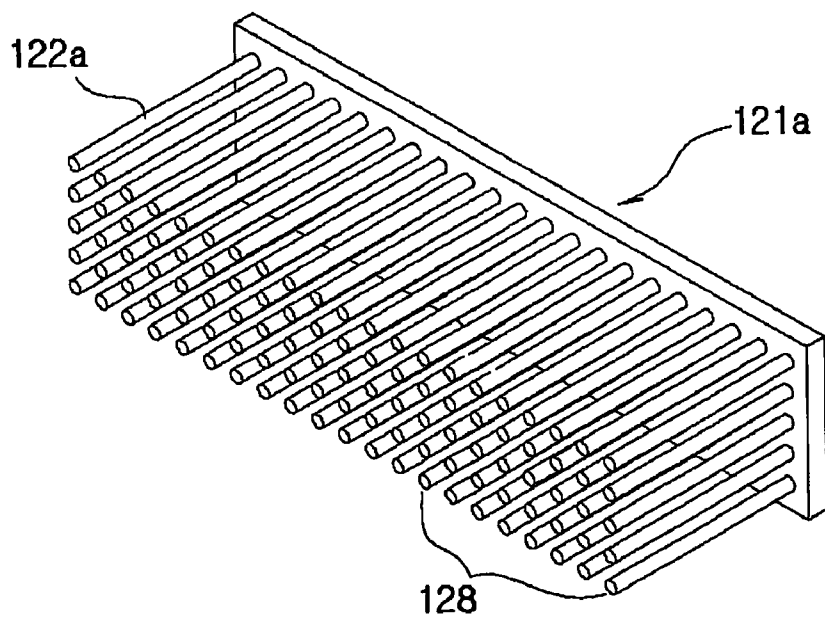

FIG. 14

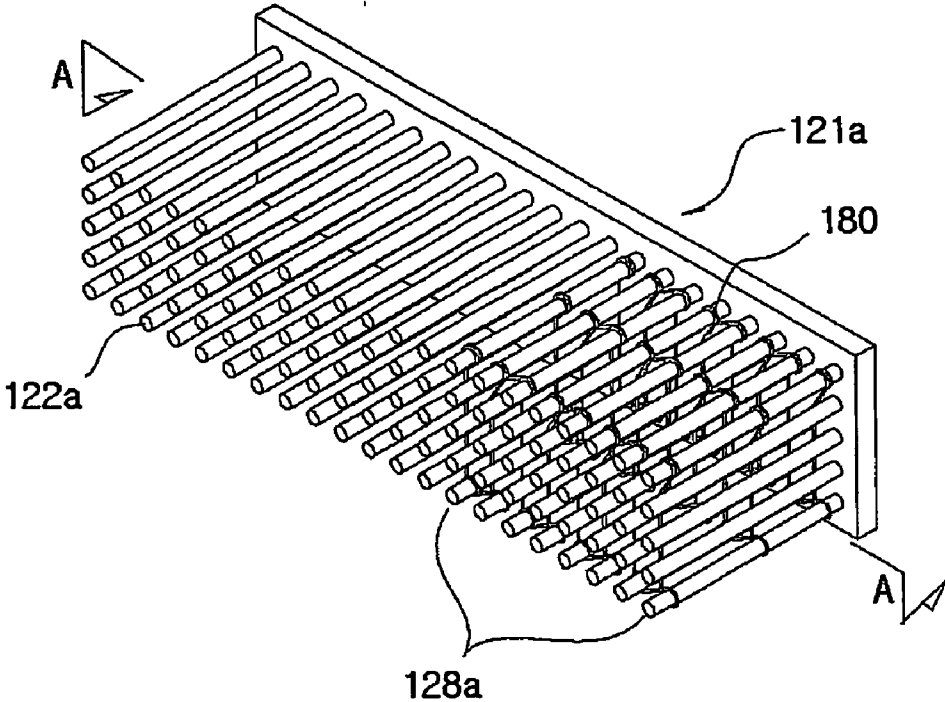

FIG. 15

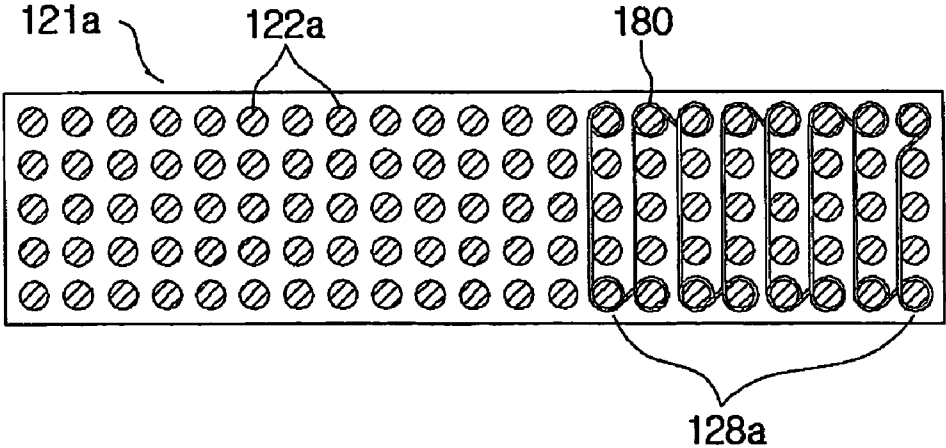

FIG. 16

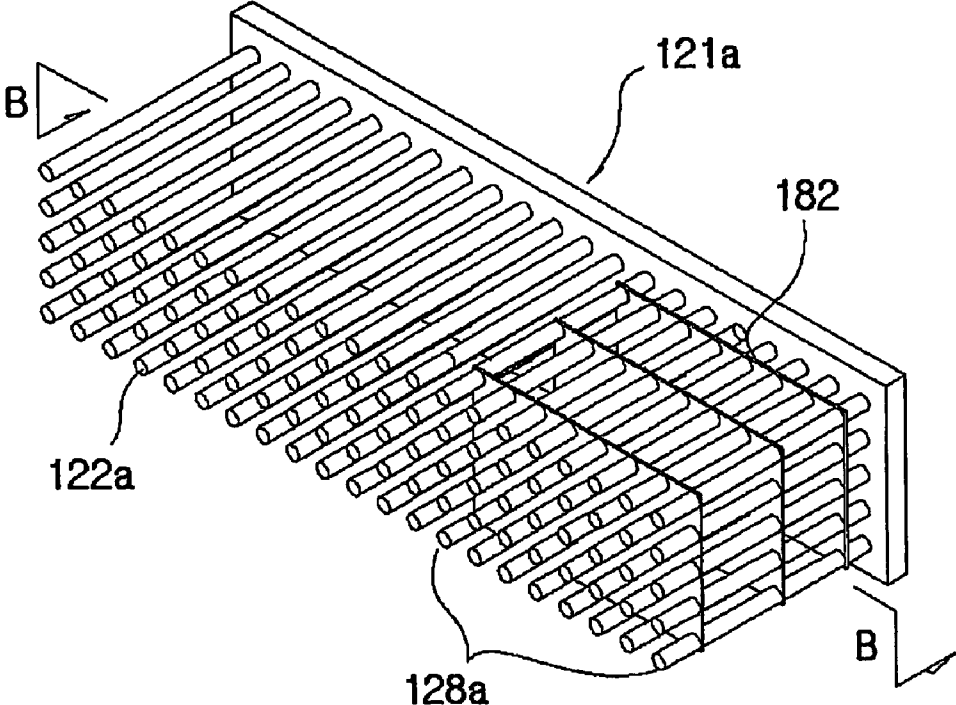

FIG. 17

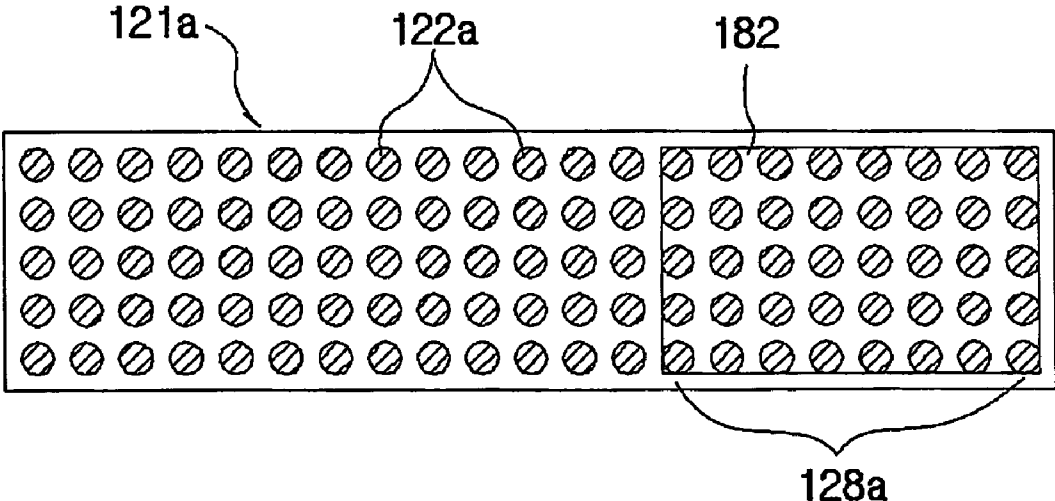

FIG. 18

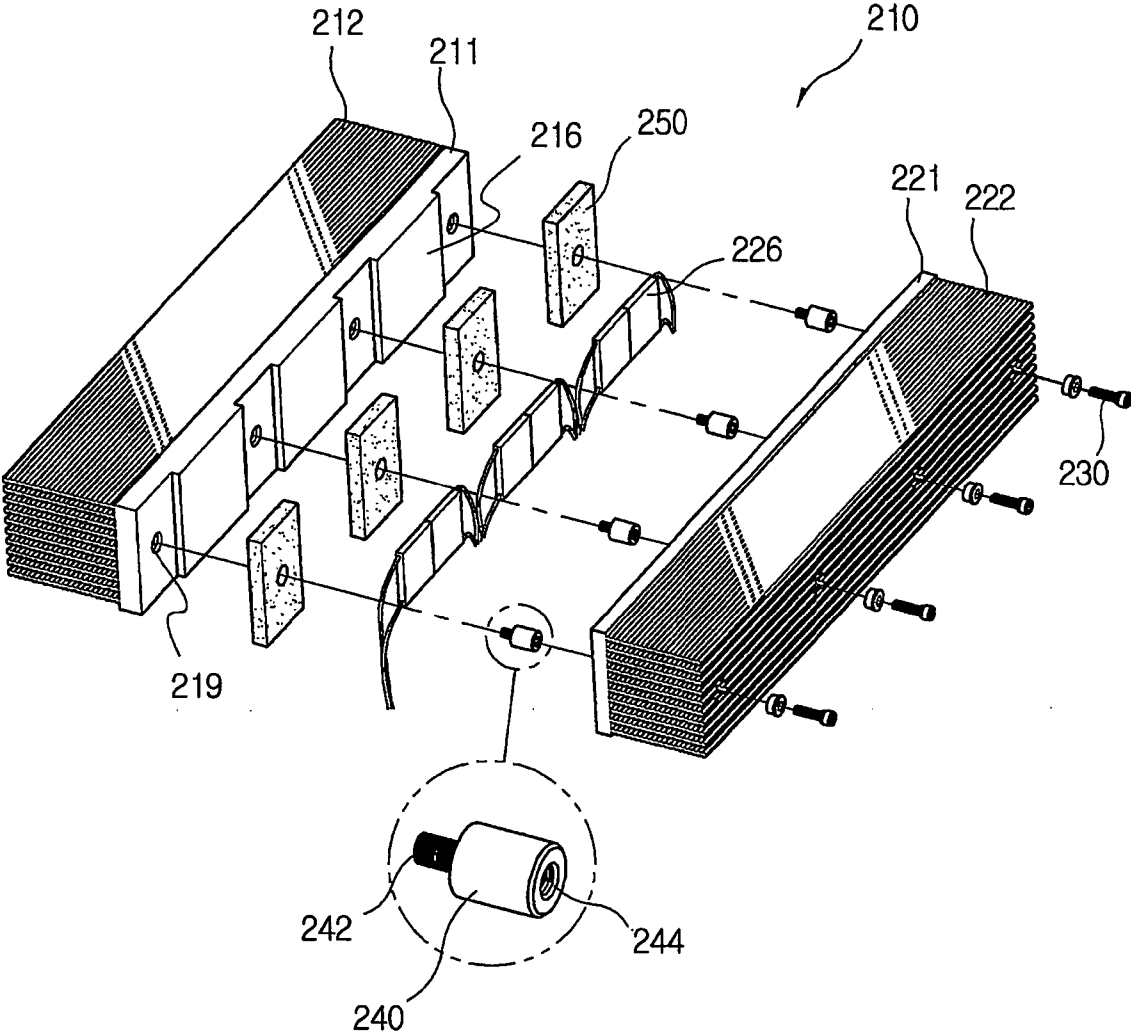

FIG. 19

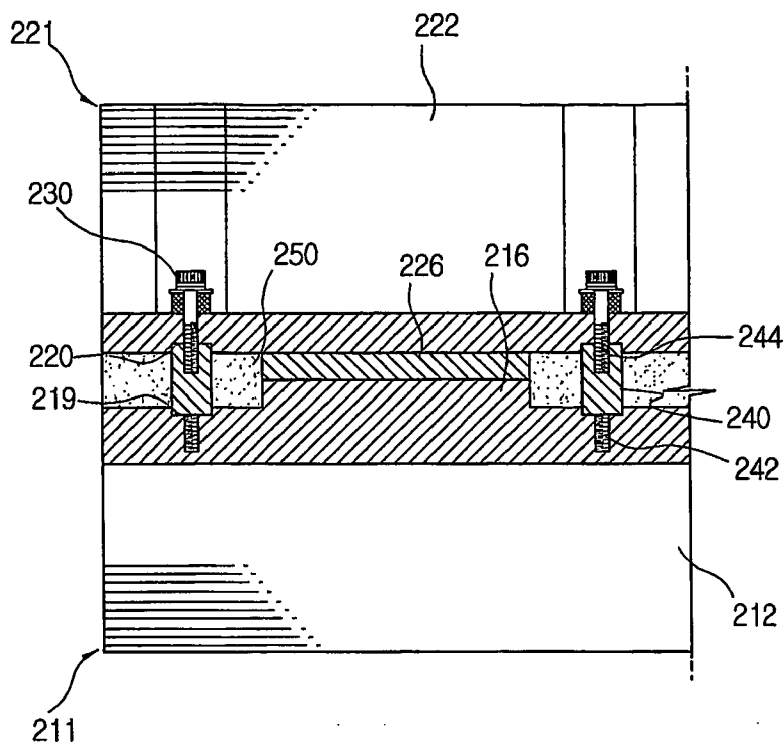
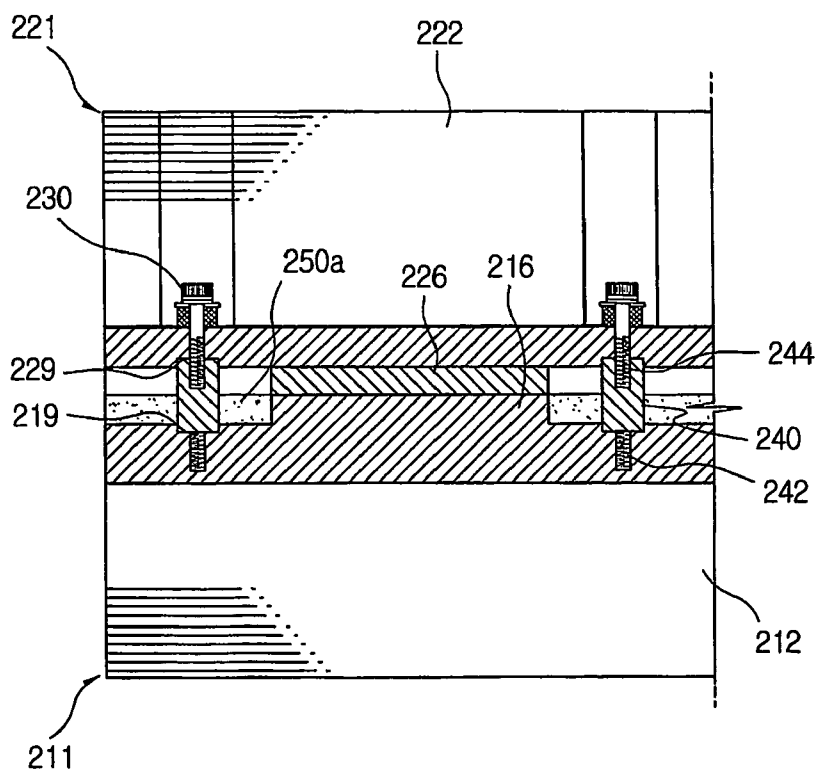

FIG. 20



**HEAT EXCHANGE UNIT INCLUDING APPARATUS TO REMOVE CONDENSED WATER**

**TECHNICAL FIELD**

[0001] The present invention relates to a heat exchange unit including an apparatus to remove condensed water, and more particularly, to a heat exchange unit including an apparatus to remove condensed water by allowing the condensed water gathered on a cooling fin part of the heat exchange unit to be evaporated to the air within the heat exchange unit itself.

[0002] Further, the present invention relates to a heat exchange unit having an apparatus to remove the condensed water, being integrally combined with the power supplying unit to supply electric current to peripheral units of a computer.

**BACKGROUND ART**

[0003] Generally, computers, communication apparatuses and electric/electronic apparatuses are constructed with a variety of parts or components each having its own function and being electrically connected by wires or cables through a printed circuit board (PCB), wherein the aforementioned apparatuses are operated or controlled according to operation of the components thereof.

[0004] While the apparatuses are being operated or controlled by operation of the components, a large amount of heat would be generated from the components if they have been used for a long time.

[0005] The heat generated from the components causes the life span of the components to be shortened and also the performances thereof to be deteriorated. Further, the heat may affect other components adjacent to a heat generating component. In a worse case, the heat may be a cause of malfunction or impossibility of data processing of the apparatuses. Therefore, a cooling device to cool down the components has been used.

[0006] The cooling device to cool down the components is provided with a hot sink having internally a projected square heat isolating part and a heat discharging fan discharging the drawn hot air to the outside.

[0007] The cooling device also comprises a cool sink having a cooling fan for supplying external air into the inside thereof to thereby generate cool air.

[0008] The cooling device is further provided a thermoelectric element disposed in the projected heat isolating part of the hot sink to transmit cool air of the cool sink, thereby cooling down the heat generated from the components of various electronic apparatuses.

[0009] For reference, the hot sink is formed with multiple heat generating fins combined with one another, and the cool sink is also formed with multiple cooling fins.

[0010] In the heat exchange unit, the cool air discharged toward discharging holes after passing through the cool sink causes condensed water to be generated due to the temperature difference from internal air.

[0011] Generation of the condensed water will be described in more detail. To describe, various electronic

apparatuses are being used under the humidity of air, which would increase by 70% or more in the season of summer.

[0012] At this time, since the temperature of cooling fins of an air conditioner decreases lower than the Dew point of air, moisture in the air is condensed on the cooling fins, to thereby generate condensed water.

[0013] Dehumidifying temperature of the air is determined depending upon a relation of temperature and humidity. The temperature of cooling fins of the cooling device used to maintain the internal temperature of the apparatuses around 20° C. is actually lower than 10° C.

[0014] The condensed water generated due to the temperature difference is flown into control parts of the various electronic apparatuses, thereby causing electric shock and malfunction thereof.

[0015] Thus, to remove the condensed water formed on the cool sink, there is a need to separately provide a discharge hose for discharging the condensed water outside and a condensed water condensing part for collecting the condensed water discharged through the discharge hose, or otherwise, to internally provide a condensed water condensing part for collecting the condensed water gathered on the cool sink.

[0016] However, if the condensed water is collected on the condensing part over the predetermined amount, the condensed water overflows and the overflowed water is flown into the control parts of the electronic apparatuses, thereby still causing electrical shock and malfunction thereof.

[0017] Also, since the power supplying unit and the heat exchange unit are respectively mounted within the computer, they need a larger space and a large number of parts to install them, thereby causing economic loss.

[0018] As a consequence, there is a need to provide separate discharging holes to discharge the heat generated within the power supplying unit and to install a separate power line to operate the heat exchange unit.

**DISCLOSURE OF INVENTION**

[0019] The present invention is conceived to solve the aforementioned problems. An object of the present invention is to provide a heat exchange unit including an apparatus to remove condensed water by allowing the condensed water gathered on a cool sink to be absorbed into a condensed water-evaporating means and the absorbed condensed water to be evaporated to the air by the hot air generated in a heat generating fin part of a hot sink.

[0020] Further, a power supplying unit to supply power to components and elements of a computer, a communication apparatus and an electric/electronic appliances is integrally combined with the heat exchange unit to cool down the heat from the components and elements of the computer, the communication apparatus and the electric/electronic appliances.

[0021] According to another object of the present invention, the inside of the power supplying unit is communicated with the heat discharging fan by a communicating tube, thereby allowing the heat generated in the power supplying unit to be discharged to the outside through the heat discharging fan.

[0022] To accomplish these and other objects, there is provided a heat exchange unit having an apparatus to remove condensed water, comprising the heat exchange unit including a hot sink equipped with a heat discharging fan, a cool sink equipped with a cooling fan, and a thermoelectric element disposed between the hot sink and the cool sink, and a condensed water-evaporating means for absorbing the condensed water gathered on the cool sink provided within the heat exchange unit and evaporating the condensed water to the air by the heat from the hot sink.

[0023] According to the present invention, the heat exchange unit including an apparatus to remove the condensed water comprises a case having internally a horizontal partition in the middle thereof, and a cover covering the top of the case.

[0024] Preferably, the heat exchange unit comprises a hot sink having a power supplying unit over the internal partition of the case and a heat discharging fan below it, a cool sink equipped with a cooling fan and a thermoelectric element disposed between the hot sink and the cool sink.

[0025] The heat exchange unit is further provided with a condensed water-evaporating means to evaporate the condensed water to the air by the heat from the hot sink after absorbing the condensed water gathered on the cool sink.

#### BRIEF DESCRIPTION OF DRAWINGS

[0026] The above and other objects and features of the present invention will become apparent from the following description of preferred embodiments given in conjunction with the accompanying drawings, in which:

[0027] **FIG. 1** is a block diagram illustrating the whole construction of a heat exchange unit including an apparatus to remove condensed water according to the present invention;

[0028] **FIG. 2** is a perspective view of the heat exchange unit including an apparatus to remove the condensed water according to the present invention;

[0029] **FIG. 3** is an exploded perspective view of the heat exchange unit including an apparatus to remove the condensed water according to the present invention;

[0030] **FIG. 4** is a sectional view illustrating an installation of an absorbing part of a condensed water-evaporating means on a cooling fin part according to the present invention;

[0031] **FIG. 5** is a sectional view illustrating an installation of an evaporating part of a condensed water-evaporating means on a heat generating fin part according to the present invention;

[0032] **FIG. 6** is a block diagram illustrating a heat exchange unit including an apparatus to remove the condensed water according to another embodiment of the present invention;

[0033] **FIG. 7** is a schematic diagram illustrating an evaporation process of condensed water in the heat exchange unit including an apparatus to remove the condensed water according to another embodiment of the present invention;

[0034] **FIG. 8** is a perspective view of the heat exchange unit including an apparatus to remove the condensed water according to another embodiment of the present invention;

[0035] **FIG. 9** is an exploded view of the heat exchange unit including an apparatus to remove the condensed water according to another embodiment of the present invention;

[0036] **FIG. 10** is a sectional view illustrating the main construction of the assembled heat exchange unit including an apparatus to remove the condensed water according to another embodiment of the present invention;

[0037] **FIG. 11** is a sectional view illustrating an installation of an absorbing part of the condensed water-evaporating means to the cooling fin part according to another embodiment of the present invention;

[0038] **FIG. 12** is a sectional view showing an installation of an evaporating part of a condensed water-evaporating means on a heat generating fin part according to another embodiment of the present invention;

[0039] **FIG. 13** is a perspective view illustrating the cooling fin part of the cool sink, being formed with annular pipes, according to another embodiment of the present invention;

[0040] **FIG. 14** is a perspective view illustrating the cooling fin part of the cool sink, being wound with wires, according to another embodiment of the present invention;

[0041] **FIG. 15** is a sectional view taken along the line of A-A of **FIG. 14**;

[0042] **FIG. 16** is a perspective view illustrating the cooling fin part of the cool sink, being combined with a partition, according to another embodiment of the present invention;

[0043] **FIG. 17** is a sectional view taken along the line of B-B of **FIG. 16**;

[0044] **FIG. 18** is an exploded perspective view illustrating a heat isolating spacer and a heat insulating member according to another embodiment of the present invention;

[0045] **FIG. 19** is a sectional view illustrating a coupling status of the heat isolating spacer and the heat insulating member of **FIG. 18**; and

[0046] **FIG. 20** is a sectional view illustrating an insulating member provided according to another embodiment of the present invention.

#### BEST MODE FOR CARRYING OUT THE INVENTION

[0047] Hereinafter, exemplary best modes of a heat exchange unit including an apparatus to remove condensed water, to carry out the present invention, will be described in detail with reference to the accompanying drawings.

[0048] **FIG. 1** is a block diagram illustrating the whole construction of a heat exchange unit including an apparatus to remove condensed water according to the present invention, **FIG. 2** is a perspective view of the heat exchange unit including an apparatus to remove the condensed water according to the present invention, **FIG. 3** is an exploded perspective view of the heat exchange unit including an apparatus to remove the condensed water according to the



present invention, **FIG. 4** is a sectional view illustrating an installation of an absorbing part of a condensed water-evaporating means on a cooling fin part according to the present invention, and **FIG. 5** is a sectional view illustrating an installation of an evaporating part of a condensed water-evaporating means on a heat generating fin part according to the present invention.

[0049] Referring to **FIGS. 1 through 5**, the heat exchange unit **1** according to the present invention comprises a hot sink **10** having internally a projected square heat isolating part **16** and a heat discharging fan **14** for discharging internal air to the outside, and a cool sink **20** having a cooling fan **24** for drawing external air and supplying the drawn air to the inside thereof.

[0050] A thermoelectric element **26** is seated on the projected heat isolating part **16** of the hot sink so as to transmit cooled air to the cool sink **20**.

[0051] The hot sink **10** and the cool sink **20** are fixed by a plurality of fixing means, and comprises respective cases **2** accommodating therein the cool sink **20** and the hot sink **10** and covers **3** covering the top parts of the cases **2**.

[0052] A condensed water-evaporating means **30** comprises an absorbing part **32** disposed below a condensed water condensing part **28** of the cooling fin part **22** on which the condensed water is collected, and an evaporating part **36** disposed below the hot sink **10** toward the discharging part **18** through which internal hot air is discharged outside.

[0053] A connection part for connecting the absorbing part **32** and the evaporating part **36** is provided, to thereby allow the condensed water absorbed through the absorbing part **32** to be transmitted to the evaporating part **36**.

[0054] A seating part **40** is positioned on the bottom of the condensed water-evaporating means **30** so as to prevent the condensed water absorbed from being flown into the inside of the heat exchange unit **1**.

[0055] To sense generation of the condensed water and facilitate evaporation of the condensed water, a structure to detect existence or non-existence of the condensed water and evaporate the condensed water according to the detection result is provided between the condensed water-evaporating means **30** and the seating part **40**.

[0056] To specify, a condensed water sensor **52** for detecting existence or non-existence of the condensed water is disposed on the bottom of the absorbing part **32** of the condensed water-evaporating means **30** and a temperature sensor **50** for detecting a temperature of the condensed water-evaporating means(?) to maintain it in a constant manner is disposed on the bottom of the evaporating part **36**.

[0057] Observing the heat exchange unit according to the present invention, if external air is drawn into the cool sink **20** by the cooling fan **24**, the drawn air is cooled down while passing through the cooling fin part **22** provided in the cool sink **20**.

[0058] The cooled air is supplied to the inside through a blowing duct **27**, to thereby cool down the heat generated in components of various electronic apparatuses.

[0059] On the surface of the cooling fin part **22** on which the cool air supplied inwardly through the blowing duct **27**

while passing through the cool sink **20** meets internal air is generated condensed water because of a temperature difference between them.

[0060] The condensed water generated so is absorbed into the absorbing part **32** below the condensed water-evaporating means **30** and moved into the evaporating part **36** of the condensed water-evaporating means **30** provided below the hot sink **10**, through the connection part **34**.

[0061] The condensed water absorbed into the condensed water-evaporating means **30** is prevented from being drawn into the inside of the heat exchange unit **1** since the condensed water-evaporating means **30** is securely seated on the seating part **40**.

[0062] At this time, the heat generated by operation of a thermoelectric element **26** is transmitted to the hot sink **10**, and the heat of the hot sink **10** heats the condensed water absorbed into the evaporating part **36** of the condensed water-evaporating means **30** to increase the temperature of 35° C. or more; on this temperature, the condensed water is well apt to be evaporated.

[0063] The condensed water heated in the evaporating part **36** of the condensed water-evaporating means **30** is evaporated to the outside through the discharging part **18**. At this time, the temperature of the hot sink **10** is in the range of about 40° C. to 50° C. or more, and the temperature of the air discharged is in the range of about 35° C. to 40° C.

[0064] The condensed water absorbed in the absorbing part **32** of the condensed water-evaporating means **30** is moved into the evaporating part **36** through the connection part **34** and the condensed water moved into the evaporating part **36** is evaporated to the outside through the discharging part **18** by the heat of a heat generating fin part **12**.

[0065] As the condensed water is evaporated in the evaporating part **36**, the condensed water absorbed into the absorbing part **32** is consecutively supplied to the evaporating part **36** through the connection part **34**.

[0066] To facilitate evaporation of the condensed water in the evaporating part **36** of the condensed water-evaporating means **30**, a heater **60** to heat the condensed water to a predetermined temperature is provided so that the condensed water is evaporated in a fast manner.

[0067] At this time, the temperature sensor **50** provided in the evaporating part **36** of the condensed water-evaporating means **30** detects the temperature of the heater **60** so that it is maintained at the temperature not harmful to humans, for example, below 60° C.

[0068] The detected temperature information is transmitted to the control part **70** so that the temperature of the heater **50** is controlled and maintained below 60° C. according to control by the control part **70**.

[0069] The control part **70** detects existence or non-existence of the condensed water in the absorbing part **32** through a condensed water sensor **52** provided in the absorbing part **36** of the condensed water-evaporating means **30**.

[0070] Information on existence or non-existence of the condensed water as sensed is transmitted to the control part **70**. Where it is determined that there is no condensed water,

the control part 70 interrupts power supply by the power supplying unit 72 to thereby interrupt operation of the heater 60.

[0071] The condensed water-evaporating means 30 is preferably made of capillary fiber having better performance in absorption and evaporation.

[0072] For reference, the capillary fiber currently in use is comprised of super infinitesimal fiber below  $\frac{1}{100}$  mm in thickness. It has been known that this kind of finely processed fiber has a water absorbing ability of three times or more higher than common fibers have.

[0073] FIG. 6 is a block diagram illustrating a heat exchange unit including an apparatus to remove the condensed water according to another embodiment of the present invention, FIG. 7 is a schematic diagram illustrating an evaporation process of condensed water in the heat exchange unit including an apparatus to remove the condensed water according to another embodiment of the present invention, FIG. 8 is a perspective view of the heat exchange unit including an apparatus to remove the condensed water according to another embodiment of the present invention, FIG. 9 is an exploded view of the heat exchange unit including an apparatus to remove the condensed water according to another embodiment of the present invention, FIG. 10 is a sectional view illustrating the main construction of the assembled heat exchange unit including an apparatus to remove the condensed water according to another embodiment of the present invention, FIG. 11 is a sectional view illustrating an installation of an absorbing part of the condensed water-evaporating means to the cooling fin part according to another embodiment of the present invention, and FIG. 12 is a sectional view showing an installation of an evaporating part of a condensed water-evaporating means on a heat generating fin part according to another embodiment of the present invention.

[0074] As illustrated in FIGS. 6 through 12, the heat exchange unit according to the present invention comprises a case 101 having a partition 107 in a horizontal direction internally installed in the middle thereof, and a cover 102 covering the top of the case 101.

[0075] On the top of the internal partition 107 of the case 101 is formed a power supplying unit 105 having a power connecting inlet 106 into which an external power line is inserted, through which the power is supplied.

[0076] According to the present invention, there is provided the heat exchange unit 110 comprising a hot sink 111 equipped with a heat discharging fan 114 below the partition 107, a cool sink equipped with a cooling fan 124, and a thermoelectric element 126 disposed between the hot sink 111 and the cool sink 121.

[0077] The power supplying unit 105 drives a computer and the heat exchange unit when the power supply line supplied externally is inserted into the power connecting inlet 106 and power is supplied to the power supplying unit 105.

[0078] At this time, the power supplied to the power supplying unit 105 is supplied respectively to a power part 172 and the thermoelectric element 126 of the heat exchange unit 100, to thereby allow the heat exchange unit 110 to be operated.

[0079] To discharge the heat generated in the power supplying unit 105 to the discharging part 118, there is provided a communicating pipe 117 communicating the power supplying unit 105 with the heat discharging fan 114 of the heat exchange unit 110.

[0080] Respective heat insulating members 108, 108a and 108b are disposed between the middle of an internal partition 107 of the case 101 and the heat exchange unit 110 and an outside of the heat exchange unit 110, that is, an inside of the cover 102, in the heat exchange unit 110, on an external face thereof and on the bottom of the heat exchange unit 110, so as to prevent loss of heat from the heat exchange unit 110.

[0081] The heat exchange unit 110 has a projected square heat insulating part 116 inside the heat exchange unit, and is provided with a hot sink having a heat discharging fan 114 to discharge internal air to the outside.

[0082] The cool sink 121 having a cooling fan 124 draws external air and supplying the drawn air into the inside is further provided.

[0083] The thermoelectric element 126 to transmit cool air to the cool sink 121 is seated on the projected heat insulating part 116 of the hot sink 111.

[0084] The hot sink 111 and the cool sink 121 are fixed by use of multiple bolts 119, and an absorbing part 132 of the condensed water-evaporating means 130 is disposed below the condensed water condensing part 128 of the cooling fin part 122 on which the condensed water is gathered.

[0085] The condensed water evaporating part 136 is disposed below the condensed water-evaporating means 130 toward the discharging part 118 of the hot sink 111 to discharge internal hot air to the outside.

[0086] The heat exchange unit 110 is provided with a connection part 134 so as to allow the condensed water absorbed in the absorbing part 132 to be transmitted to the evaporating part 136.

[0087] The bolt 119 comprises a metallic bolt 140 as a fixing means, by which the hot sink 111 and the cool sink 121 are fixed to each other.

[0088] The heat exchange unit 110 is provided with a seating part 140 on the bottom of the condensed water-evaporating means 130 to prevent the condensed water absorbed from being flown around the inside of the heat exchange unit 110.

[0089] In order to sense generation of the condensed water and facilitate evaporation of the condensed water, there is provided a structure to detect existence or non-existence of the condensed water between the condensed water-evaporating means 130 and the seating part 140 and evaporate the condensed water according to a detection result.

[0090] In other words, a condensed water sensor 152 to detect existence or non-existence of the condensed water is disposed on the bottom of the absorbing part 132 of the condensed water-evaporating means 130, and a temperature sensor to sense a temperature is disposed on the bottom of the evaporating part 136 so as to maintain it under the predetermined temperature.

[0091] A control part 170 is provided, which receives information on existence or non-use of the condensed water

from the condensed water sensor **152** to or not to operate the heater **160**, and receives information from the temperature sensor **150** to prevent excessive increase of the predetermined temperature.

[0092] The control part **170** senses an internal temperature of a computer case and a temperature of a CPU discharging fan and determines a rotation speed of the cooling fan of the cool sink and operation or non-operation of the discharging part of the hot sink based on the sensed information.

[0093] Observing the heat exchange unit according to the present invention, if external air is drawn into the cool sink **121** by the cooling fan **124**, the drawn air is cooled down while passing through the cooling fin part **122** provided in the cool sink **121**.

[0094] The cooled air is supplied inwardly through a blowing duct **127**, thereby cooling down the heat generated in components of various electronic appliances.

[0095] The cool air supplied inwardly through the blowing duct **127** after passing through the cool sink **121** generates condensed water due to the temperature difference from the internal air on the surface of the cooling fin part **122**, the point of which the cool air meets the internal air.

[0096] The generated condensed water is absorbed into the absorbing part **132** of the condensed water-evaporating means **130** and moved through the connection part **134** into the evaporating part **136** of the condensed water-evaporating means **130** provided below the hot sink **111**.

[0097] Meanwhile, since the condensed water-evaporating means **130** is seated on the seating part **140**, the condensed water absorbed into the condensed water-evaporating means **130** is blocked from being flown into the inside of the heat exchange unit **110**.

[0098] At this time, the thermoelectric element **126** supplied power from the power supplying unit is operated, and thus, generated heat is transmitted into the hot sink **111**.

[0099] Heat of the hot sink **111** serves to heat the temperature of the condensed water absorbed in the evaporating part **136** of the condensed water-evaporating means **130** to about 35° C. or more, the temperature of which better evaporation is made.

[0100] The condensed water heated in the evaporating part **136** of the condensed water-evaporating means **130** is evaporated to the outside through the discharging part **118**.

[0101] At this time, the temperature of the hot sink **111** is in the range of about 40° C. to 50° C. or more, and the temperature of the discharged air is in the range of about 35° C. to 40° C.

[0102] The condensed water absorbed into the absorbing part **132** of the condensed water-evaporating means **130** is moved to the evaporating part **136** through the connection part **134**.

[0103] The condensed water moved into the evaporating part **136** is evaporated to the outside through the discharging part **118** by the heat of the heat generating fin part **112**.

[0104] As the condensed water is evaporated in the evaporating part **136**, the condensed water absorbed into the absorbing part **132** is consecutively supplied to the evaporating part through the connection part **134**.

[0105] To facilitate evaporation of the condensed water in the evaporating part **136** of the condensed water-evaporating means **130**, a heater **160** is provided so as to heat the condensed water to a predetermined temperature and evaporate the condensed water in a fast manner.

[0106] To maintain the temperature of the heater **160** below 60° C., not harmful to human body, the temperature thereof is detected by the temperature sensor **150** provided in the evaporating part **136** of the condensed water-evaporating means **130**.

[0107] The detected temperature information is transmitted to the control part **170** and, on this basis, the control part **170** controls the heater **160**, the temperature of which is maintained below 65° C.

[0108] The control part **170** senses existence or non-existence of the condensed water in the absorbing part **132** through the condensed water sensor **152** provided in the absorbing part **136** of the condensed water-evaporating means **130**.

[0109] Information on existence or non-existence of the condensed water as sensed is transmitted to the control part **170**. Where it is determined that there is no existence of the condensed water, the control part **170** interrupts power supply to the power supplying part **172** so as to interrupt operation of the heater **160**.

[0110] The condensed water-evaporating means **130** is preferably comprised of capillary fiber having an excellent performance in absorption and evaporation.

[0111] For reference, the capillary fiber currently in use is comprised of super infinitesimal fiber below 1/100 mm in thickness(?). It has been known that this kind of finely processed fiber has a water absorbing ability of three times or more than common fibers have.

[0112] The heat generated by operation of the power supplying unit **105** is absorbed through the communicating pipe **117** by use of the absorbing ability of the heat discharging fan **116** and is discharged to the discharging part **118**.

[0113] On the cover **102** covering the top of the case **101** is formed a plurality of passing holes **103** on the position of the power supplying unit **105**.

[0114] By allowing a part of the heat generated in the power supplying unit **105** to be discharged through the passing holes **103**, when the heat is discharged through the discharging part **118** to the outside, the heat generated in the power supplying unit is discharged more smoothly.

[0115] FIG. 13 is a perspective view illustrating the cooling fin part of the cool sink, being formed with annular pipes, according to another embodiment of the present invention. As illustrated, the cooling fin part **122a** of the cool sink **121a** is formed with multiple annular pipes, making the condensed water gathered on the condensing part **128** of the cooling fin part **1221** smoothly drop to the absorbing part **132** of the condensed water-evaporating means **130**.

[0116] FIGS. 13 and 14 shows the cooling fin parts of the cool sink being formed with annular pipes according to the present invention, engaged with wires. It is designed that the condensed water generated on the condensed water condensing part **128** of the cooling fin part **122a** of the cool sink

**121** drops to the absorbing part **132** according to the amount of the condensed water generated, that is, when the condensed water reaches a water drop of predetermined size.

[0117] Therefore, a multiplicity of wires **180** wound vertically are provided in the condensed water condensing part **128** on which the condensed water from the annular pipe-shaped cooling fin part **122a** is collected.

[0118] This allows the condensed water to flow and drop to the absorbing part **132** along the wires **180** whenever generated, regardless of the amount of water drop gathered on the cooling fin part **122a**, thereby preventing the condensed water from staying on the annular pipe-shaped cooling fin part **122a**.

[0119] FIGS. 16 and 17 both illustrate partitions provided in the annular pipe-shaped cooling fin part of the cool sink according to the present invention. As illustrated, the plurality of partitions provided in the condensed water condensing part **128a** of the cooling fin part **122a** has the same effects as providing the wires **180** to the cooling fin part **122a**.

[0120] As observed above in reference to the preferred embodiments of the present invention, there is no need to provide a separate discharging device to collect and remove the condensed water, thereby preventing electric shock and false operation of the computer due to the condensed water.

[0121] FIGS. 18 and 19 both illustrate a heat insulating spacer **240** to block heat transmission between the hot sink **211** and the cool sink **221** according to another embodiment of the present invention.

[0122] The heat insulating spacer **240** is formed with a screw shaft **242** to be engaged into the hot sink **211**, a screw hole **244** in opposition, into which the bolt **230** inserted into the cool sink is engaged, and securing holes **219** and **229** through which the heat insulating spacer **240** is secured onto the hot sink **211** and the cool sink **221**.

[0123] The hot sink **211** and the cool sink **221** are not fixed by engaging the metallic bolt **230** as a fixing means to fix them each other directly into the hot sink **211**, but the hot sink **211** and the cool sink **221** are fixed by connecting the heat insulating spacer **240** effective in heat insulation, with the middle of between them, thereby having an excellent heat insulation effect.

[0124] Also, loss from heat pumping of the thermoelectric element **226** by which the heat of the hot sink **211** is transmitted toward the cool sink **221** is prevented.

[0125] Where there is no heat insulating spacer **240** between the hot sink **211** and the cool sink **221**, the metallic bolt **230** becomes to have the heat conductivity of 58.9~41.9 [w/mk].

[0126] However, by providing the heat insulating spacer **240** to block heat transmission, the heat conductivity of the metallic bolt **230** is reduced to 2.09 to 1.57[w/mk].

[0127] Accordingly, the construction of the bolt **230** coupling the hot sink **211** and the cool sink **221** has a heat insulating effect of 29 times at maximum.

[0128] Since the projected heat insulating part **216** inside the hot sink onto which the thermoelectric element **226** is seated is projected, the space between the hot sink **211** and

the cool sink **221** becomes widened, and thicker heat insulating member **240** can be disposed, thereby increasing the heat insulating effect.

[0129] Since the heat insulating member **250** is disposed in the space between the hot sink **211** and the cool sink **221**, that is, on the circumference of the projected heat insulating part **216**, transmission of the heat generated in the hot sink **211** to the cool sink **221** is blocked.

[0130] FIG. 20 illustrates a heat insulating member according to another embodiment of the present invention. As illustrated, the heat insulating member **250a** provided between the hot sink **211** and the cool sink **221** is of the same in thickness as the projected heat insulating part **219** of the hot sink **211**.

[0131] Since a space between the hot sink **211** and the cool sink **221** as thick as the thermoelectric element **226** is separately formed, transmission of the heat generated in the hot sink **211** to the cool sink **221** is first interrupted by the heat insulating member **250a**.

[0132] Then, the heat transmission is secondarily interrupted in the space between the hot sink **211** and the cool sink **221**, thereby giving double heat insulating effect.

#### INDUSTRIAL APPLICABILITY

[0133] As described above, since the condensed water is evaporated by the heat generated in the hot sink of the heat exchange unit according to the present invention, no energy to evaporate to the condensed water is separately needed, thereby increasing economical availability.

[0134] The condensed water is first evaporated by the heat generated in the heat generating part by the heater provided in the evaporating part of the condensed water evaporating part, and it is secondarily evaporated by the heat of the heater, thereby being capable of evaporating the condensed water to the external air rapidly.

[0135] Since the power supplying unit to be supplied power to drive the computer and then apply the power and the heat exchange unit are integrally combined, when this is mounted inside the computer, the space to be occupied thereby is reduced.

[0136] In addition, since a heat insulating spacer is provided between the hot sink and the cool sink, a metallic bolt engaged into the cool sink is blocked from directly contacting the hot sink, thereby reducing loss of heat.

[0137] Although the present invention has been described in connection with the preferred embodiments illustrated in the accompanying drawings, it should be understood that the present invention is not limited thereto and those skilled in the art can make various modifications and changes without departing from the scope of the invention.

1. A heat exchange unit including an apparatus to remove condensed water, comprising:

the heat exchange unit having a hot sink equipped with a heat discharging fan, a cool sink equipped with a cooling fan, and a thermoelectric element disposed between the hot sink and the cool sink; and

a condensed water-evaporating means for absorbing the condensed water gathered on the cool sink provided

within the heat exchange unit and evaporating the condensed water to the air by the heat of the hot sink.

**2.** The heat exchange unit as claimed in claim 1, wherein the condensed water-evaporating means is made of capillary fiber.

**3.** The heat exchange unit as claimed in claim 1, wherein the condensed water-evaporating means comprises:

an absorbing part positioned below a cooling fin part of the cool sink;

an evaporating part positioned below a discharging part of the hot sink; and

a connection part connecting the absorbing part and the evaporating part.

**4.** The heat exchange unit as claimed in claim 3, further comprising a seating part on which the condensed water-evaporating means is seated.

**5.** The heat exchange unit as claimed in claim 3, further comprising:

a condensed water sensor disposed in the absorbing part of the condensed water-evaporating means;

a temperature sensor disposed in the evaporating part;

a heater disposed in the evaporating part; and

a control part driving the heater according to signals from the condensed water sensor and the temperature sensor.

**6.** The heat exchange unit as claimed in claim 3, wherein the cooling fin part of the cool sink is comprised of annular pipe-shaped cooling fins.

**7.** The heat exchange unit as claimed in claim 6, wherein the annular pipe-shaped cooling fin part is wound by wires.

**8.** The heat exchange unit as claimed in claim 6, wherein the annular pipe-shaped cooling fin part comprises a plurality of partitions.

**9.** The heat exchange unit as claimed in claim 1 or 2, further comprising a case and a cover, wherein the cover has a plurality of passing holes.

**10.** A heat exchange unit including an apparatus to remove the condensed water, comprising:

a case having internally a horizontal partition in the middle thereof;

a cover covering the top of the case;

a power supplying unit disposed in the internal partition of the cover; and

the heat exchange unit disposed below the partition inside the case,

wherein the heat exchange unit includes a hot sink equipped with a heat discharging fan, a cool sink equipped with a cooling fan and a thermoelectric element disposed between the hot sink and the cool sink.

**11.** The heat exchange unit as claimed in claim 10, further comprising a condensed water-evaporating means for absorbing the condensed water gathered on the cool sink and evaporating the condensed water to the air by the heat of the hot sink.

**12.** The heat exchange unit as claimed in claim 11, wherein the condensed water-evaporating means is made of capillary fiber.

**13.** The heat exchange unit as claimed in claim 11, wherein the condensed water-evaporating means comprises:

an absorbing part positioned below a cooling fin part of the cool sink;

an evaporating part positioned below a discharging part of the hot sink; and

a connection part connecting the absorbing part and the evaporating part.

**14.** The heat exchange unit as claimed in claim 13, further comprising a seating part on which the condensed water-evaporating means is seated.

**15.** The heat exchange unit as claimed in claim 13, further comprising:

a condensed water sensor disposed in the absorbing part of the condensed water-evaporating means;

a temperature sensor disposed in the evaporating part;

a heater disposed in the evaporating part; and

a control part driving the heater according to signals from the condensed water sensor and the temperature sensor.

**16.** The heat exchange unit as claimed in claim 13, wherein the cooling fin part comprises annular pipe-shaped cooling fins.

**17.** The heat exchange unit as claimed in claim 16, wherein the annular pipe-shaped cooling fin part is wound by wires.

**18.** The heat exchange unit as claimed in claim 16, wherein the annular pipe-shaped cooling fin part comprises a plurality of partitions.

**19.** The heat exchange unit as claimed in claim 10, further comprising heat insulating members respectively in the lower part and the side part of the partition of the case,

wherein the cover is formed with multiple passing holes.

**20.** The heat exchange unit as claimed in claim 10, further comprising a communicating pipe by which the power supplying unit and the heat discharging fan are allowed for communication with each other.

**21.** The heat exchange unit as claimed in claim 10, wherein the hot sink is formed with a plurality of projected heat insulating parts on which the thermoelectric element is seated.

**22.** The heat exchange unit as claimed in claim 10, wherein a heat insulating spacer is disposed between the hot sink and the cool sink.

**23.** The heat exchange unit as claimed in claim 22, wherein the heat insulating spacer is formed with a screw shaft to be engaged with the hot sink, and a screw hole on the other side into which a bolt inserted into the cool sink is engaged.

**24.** The heat exchange unit as claimed in claim 22, wherein securing holes on which the heat insulating spacer is seated are formed on the hot sink and the cool sink.

**25.** The heat exchange unit as claimed in claim 10, wherein the heat insulating member is disposed between the hot sink and the cool sink.