

(19) World Intellectual Property Organization
International Bureau



(43) International Publication Date
10 December 2009 (10.12.2009)

(10) International Publication Number
WO 2009/149093 A1

(51) International Patent Classification:
A61F 2/08 (2006.01)

(21) International Application Number:
PCT/US2009/045985

(22) International Filing Date:
2 June 2009 (02.06.2009)

(25) Filing Language: English

(26) Publication Language: English

(30) Priority Data:
61/130,791 2 June 2008 (02.06.2008) US

(71) Applicant (for all designated States except US): **UNIVERSITY OF MEDICINE AND DENTISTRY OF NEW JERSEY** [US/US]; 1 Worlds Fair Drive, Somerset, NJ 08873 (US).

(72) Inventors; and

(75) Inventors/Applicants (for US only): **GATT, Charles, J.** [US/US]; 121 Bedens Brook Road, Skillman, NJ 08558 (US). **BALINT, Eric, A.** [US/US]; 14 Fresh Ponds Road, East Brunswick, NJ 08816 (US). **DUNN, Michael, G.** [US/US]; 10 Tall Woods Drive, Manalapan, NJ 07726 (US).

(74) Agents: **VASILYEV, Vyacheslav** et al.; Fox Rothschild Llp, 997 Lenox Drive, Bldg. #3, Lawrenceville, NJ 08648 (US).

(81) Designated States (unless otherwise indicated, for every kind of national protection available): AE, AG, AL, AM, AO, AT, AU, AZ, BA, BB, BG, BH, BR, BW, BY, BZ, CA, CH, CL, CN, CO, CR, CU, CZ, DE, DK, DM, DO, DZ, EC, EE, EG, ES, FI, GB, GD, GE, GH, GM, GT, HN, HR, HU, ID, IL, IN, IS, JP, KE, KG, KM, KN, KP, KR, KZ, LA, LC, LK, LR, LS, LT, LU, LY, MA, MD, ME, MG, MK, MN, MW, MX, MY, MZ, NA, NG, NI, NO, NZ, OM, PG, PH, PL, PT, RO, RS, RU, SC, SD, SE, SG, SK, SL, SM, ST, SV, SY, TJ, TM, TN, TR, TT, TZ, UA, UG, US, UZ, VC, VN, ZA, ZM, ZW.

(84) Designated States (unless otherwise indicated, for every kind of regional protection available): ARIPO (BW, GH, GM, KE, LS, MW, MZ, NA, SD, SL, SZ, TZ, UG, ZM, ZW), Eurasian (AM, AZ, BY, KG, KZ, MD, RU, TJ, TM), European (AT, BE, BG, CH, CY, CZ, DE, DK, EE, ES, FI, FR, GB, GR, HR, HU, IE, IS, IT, LT, LU, LV, MC, MK, MT, NL, NO, PL, PT, RO, SE, SI, SK, TR), OAPI (BF, BJ, CF, CG, CI, CM, GA, GN, GQ, GW, ML, MR, NE, SN, TD, TG).

Published:

— with international search report (Art. 21(3))

(54) Title: TISSUE ENGINEERED FIBROCARILAGE REPLACEMENT

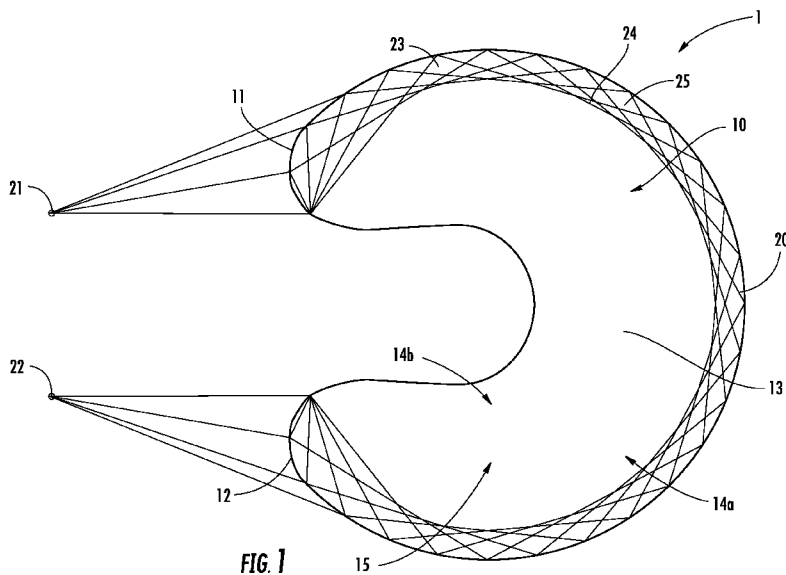

(57) Abstract: Fibrocartilage implants characterized by circumferential fiber networks embedded in arcuate or torroidal scaffolds with orthogonal fiber networks embedded therein to prevent separation of the circumferential fiber networks. The fiber networks convert axial compressive forces on the scaffolds to tensile loads on the circumferential fibers. Artificial knee meniscus and vertebral disc implants are disclosed, as well as articular disc implants for joints such as the temporomandibular joint and wrist. Methods for implanting the fibrocartilage devices are also disclosed.



WO 2009/149093 A1

TISSUE ENGINEERED FIBROCARILAGE REPLACEMENT

CROSS-REFERENCE TO RELATED APPLICATIONS

This application claims the benefit of U.S. Provisional Application Serial No. 61/130,791, filed June 2, 2008, the disclosure of which is incorporated herein by reference in its entirety.

FIELD OF THE INVENTION

This invention relates to methods and devices for replacement of severely damaged fibrocartilage tissue and, in particular, to the replacement of the lateral or medial meniscus of the knee.

BACKGROUND

The menisci are two C-shaped discs of fibrocartilage found between the condyles of the femur and the tibial plateau which play a critical role in the load transmission, load distribution, shock absorption, joint stability, and lubrication of the knee. Despite the recognized importance of the tissue, arthroscopic removal of a torn meniscus is one of the most common orthopedic procedures performed in the United States. Because the tissue has limited healing potential, the clinical outcomes of subtotal meniscectomies are generally poor. At this time, a reliable surgical procedure to replace significant loss of meniscal tissue does not exist. There is no autologous procedure to replace the meniscus and the results of allograft replacement are unreliable.

Another approach is that of tissue engineering. Current approaches include synthetic polymer scaffolds and collagen meniscus implants. With synthetic polymer

scaffolds, polyurethane sponges are used to replace the meniscus. This approach has led to inconsistent results. Fibrocartilage growth is seen in some studies using this technology while in others fibrous tissue did not remodel
5 into fibrocartilage. The underlying cartilage was protected in some studies but not protected in others.

Another type of meniscus implant uses a sponge containing collagen, hyaluronic acid and chondroitin sulfate. There is promising preliminary data for this implant, but it
10 is not widely accepted by the orthopedic community because of issues with cytotoxic byproducts of cross-linking and scaffold shrinkage.

Both of these approaches generate an amorphous structure, the mechanical properties of which may not be
15 appropriate for a device designed to replace the meniscus. Thus, while scaffold technology holds promise, no methods have met with the clinical success necessary for acceptance by the orthopedic community. There remains a need for a tissue engineered scaffold with the necessary mechanical
20 properties and biocompatibility for treatment of significant meniscal damage.

SUMMARY

This need is met by the present invention. The present
25 invention incorporates the discovery that the shortcomings of prior art implants can be overcome by reinforcement of the scaffold with a fiber matrix extending in a circumferential direction along the scaffold, the fibers of which are in turn held together by scaffold matrix fibers embedded
30 orthogonally to the circumferential fibers. The resulting configuration behaves like natural fibrocartilage that

translates an axial compressive load into a circumferential tensile load. When the implant is an artificial knee meniscus, the implant translates the axial compressive load exerted by the femur on the implant into a tensile load
5 propagated in the circumferential direction of the scaffold, like a natural meniscus.

In one aspect, the present invention thus provides a fiber reinforced implant for use as a temporary replacement for significantly damaged fibrocartilage tissue, such as
10 meniscal tissue of the knee, jaw or wrist, or an intervertebral disc. The inventive implant is constructed of resorbable natural or synthetic biomaterials which allow for infiltration, attachment and proliferation of cells from the surrounding tissues. The implant of the present invention is
15 a natural or synthetic scaffold having the shape and geometry of the original undamaged fibrocartilage with a reinforcing matrix embedded therein.

Therefore, according to one embodiment of the present invention, an artificial fibrocartilage implant is provided
20 in which an arcuate or torroidal scaffold has a circumferential fiber network embedded therein and an orthogonal fiber network embedded in the scaffold to prevent separation of the circumferential fiber network, wherein the fiber networks convert an axial compressive force on the scaffold
25 to tensile loads along the circumferential fiber network.

According to arcuate embodiments of the present invention, the arcuate scaffold has an anterior end, a posterior end and a middle section therebetween defining a curved path between the anterior and posterior ends. The circumferential
30 fiber network extends between the anterior and posterior ends along the path of the curve and exits the anterior and

posterior ends of the scaffold to form respective anterior and posterior attachment points.

According to a more specific arcuate embodiment of the present invention, the arcuate implant is fabricated in the shape of a knee meniscus. Another embodiment of this aspect of the present invention therefore provides an artificial knee meniscus implant with a c-shaped scaffold having an arcuate middle section extending between an anterior end and a posterior end and a reinforcing fiber network embedded in the scaffold, wherein the fibers of the network exit each end of the scaffold to form respective anterior and posterior attachment points and the fiber network converts an axial compressive force on the scaffold to tensile loads on the attachment points.

According to a more specific embodiment of the knee meniscus of the present invention, at least a portion the fiber network extends along the arcuate middle section in a substantially circumferential direction. According to an even more specific embodiment, the fiber network further includes an orthogonal fiber network embedded within the scaffold to prevent separation of the circumferential fiber network. In a preferred embodiment the artificial knee meniscus has a wedge-shaped cross-section substantially equivalent to a human knee meniscus.

According to another more specific embodiment of the arcuate and torroidal menisci of the present invention, the inventive implants have at least one peripheral attachment point. In a preferred embodiment, at least one peripheral attachment point coincides with a point at which the circumferential fiber network intersects with the orthogonal fiber network. In another preferred embodiment, the fiber

network(s) extend throughout the wedge-shaped cross section of the arcuate middle section.

According to one torroidal embodiment of the invention, the inventive implant is a torroidal-shaped scaffold having the circumferential and orthogonal fiber networks of the present invention. Such a device is particularly useful for replacement of intervertebral discs or temporomandibular joint discs. Artificial implants according to this embodiment of the present invention are fabricated in the shape of a vertebral disc or an articular disc for a joint.

More specific torroidal embodiments have at least one peripheral attachment point. In preferred versions of this embodiment, at least one peripheral attachment point coincides with a point at which the circumferential fiber network intersects with the orthogonal fiber network.

According to one torroidal embodiment torroidal implants are fabricated in the shape of a vertebral disc, wherein the torroidal-shaped scaffold defines an interior cavity filled with a biocompatible material with physical properties equivalent to the properties of the nucleus pulposus of a human vertebral disc. According to another torroidal embodiment, torroidal implants are fabricated in the shape of articular disc, for example, in the shape of the meniscus of the temporomandibular joint or the wrist.

In any of the inventive embodiments at least one of the scaffold, the circumferential fiber network or the orthogonal fiber network may be formed from a material selected from proteins, proteoglycans, biocompatible synthetic polymers and combinations thereof. In some embodiments the material is bioresorbable. In other embodiments the proteins

comprise collagen, and in certain of these embodiments the collagen is cross-linked.

In any of the inventive embodiments at least one of the scaffold, the circumferential fiber network or orthogonal
5 fiber network is formed from a biocompatible synthetic poly-
meric material. In some embodiments the polymeric material
is bioresorbable.

According to another aspect of the present invention, a
method is provided for replacement of a damaged knee
10 meniscus. Methods according to this aspect of the present
invention include the steps of:

replacing a damaged meniscus with a knee meniscus
implant according to the present invention by
inserting a knee meniscus implant according to the
15 present invention, having anterior and posterior
attachment points, between the tibial plateau
characterized by having anterior and posterior
anchor plugs inserted therein, and the corresponding
femur condyle; and

20 securing the anterior and posterior attachment
points of the implant to the corresponding anterior
and posterior anchor plugs.

According to yet another aspect of the present
invention, a method is provided for fabricating a soft
25 tissue repair implant such as a meniscus implant. Methods
according to this aspect of the present invention include
the steps of:

forming a reinforcement matrix with at least
one fiber; and

embedding the reinforcement matrix into a scaffold, wherein the scaffold has an arcuate middle section extending between an anterior end and a posterior end; and wherein the at least one fiber
5 exits each end of the scaffold.

By creating an implant that has the same geometry as that of the normal tissue, along with a network of embedded, reinforcing fibers, the mechanics of the natural tissue can
10 be replicated. As cells infiltrate this implant, they will experience the same mechanical environment of that of a normal tissue, thus promoting the formation of neo-fibrocartilaginous tissue which has the biological and mechanical properties to function as a load-bearing
15 structure.

BRIEF DESCRIPTION OF THE FIGURES

Figs. 1 and 2 are top views of one embodiment of the instant device;

20 Fig. 3 presents a diagram of forces on the instant device when the device is implanted;

Fig. 4 is a top view of the device in Figs. 1 and 2 with another embodiment of the reinforcing matrix;

25 Fig. 5a is a top view of a torroidal embodiment of the instant device; and Figs. 5b and 5c are elapsed time perspective views of a torroidal embodiment as it is being wound;

Fig. 6 presents a desirable degradation profiles for polymers suitable for use in instant devices;

Figs. 7a-7b show a base plate pattern for fabrication of meniscus scaffolds;

Figs. 8a-8g show the organization of embedded fibers;

Fig. 9 presents the results from a primary mechanical evaluation of the tensile strength of the scaffold of the invention;

Figs. 10a-10b present the results of an advanced mechanical evaluation for the "No Scaffold" group;

Figs. 11a-11b present the results of an advanced mechanical evaluation for the "100% Collagen Scaffold" group;

Figs. 12a-12b present the results of an advanced mechanical evaluation for the "500 Fiber Scaffold" group;

Figs. 13a-13b present the results of an advanced mechanical evaluation for the "1000 Fiber Scaffold" group;

Fig. 14 presents the results of an *in vitro* evaluation of the scaffold of the invention; and

Figs. 15a-15f present the results of an *in vivo* evaluation of the scaffold of the invention.

20

DETAILED DESCRIPTION

The instant implant improves upon current meniscus scaffolding approaches in conjunction with current tendon/ligament scaffolding approaches. With regard to tissue-type, the meniscus can be viewed as a combination of organized fibrous connective tissue predominant at its outer portion (i.e. tendon/ligament) and cartilaginous tissue at its inner portion. This extracellular matrix (ECM) organization occurs because of the way the meniscus is loaded under normal conditions.

30

For the meniscus of the knee, during static or dynamic weight-bearing the tissue is compressed by the femur. Because of the geometry of the meniscus (C-shaped with wedge-shaped cross-section), this axial load extrudes the tissue from the joint capsule. This extrusion is resisted by the anterior and posterior attachments to the tibial plateau, resulting in the generation of tensile hoop stresses directed along the circumferentially arranged collagen fibers within the tissue.

The hoop stresses are predominantly developed near the periphery of the tissue, where the ECM is more tendon-like. Near the inner margin, the tissue primarily undergoes standard compression, meaning the ECM organization is closer to that of cartilage.

Although the instant implant is described in relation to making and using a knee meniscus replacement device, the teachings of the instant disclosure may also be applied to make and use implants for replacing other tissues similar in nature and function to the meniscus, such as intervertebral discs, temporomandibular discs, wrist menisci, and the like. These tissues are similar to the knee meniscus in that they are composed of fibrocartilage and function as load transmitters and distributors to prevent high-stress bone-on-bone contact that is detrimental to the underlying cartilage. It will also be understood that the instant teachings may be applied to make and use implants for both human and animal patients.

Accordingly, one aspect of the invention provides an implant 1 comprising a scaffold 10 and reinforcing matrix 14 embedded in the scaffold 10 as shown in Fig. 1. The shape and geometry of the scaffold, and consequently the implant,

is based on the shape and geometry of the soft tissue in need of replacement. Thus, in the case of a meniscus implant, the scaffold may be constructed as a c-shaped disc with a wedge-like cross-section, similarly to a knee
5 meniscus. Furthermore, it may be shaped concave on the top, which would come in contact with femur, and flat on the bottom, which would rest on the tibial plateau. Although not necessary, the reinforcing matrix may also have the same general shape and geometry as the scaffold.

10 The scaffold 10 includes an anterior end 11, a posterior end 12 and a middle section 13 defining a path between the anterior end 11 and the posterior end 12. In a meniscus replacement device, the middle section is essentially arc-shaped and defines a curved path between
15 said anterior and posterior ends. The scaffold also has peripheral regions 14a and 14b and an inner region 15 between the peripheral regions 14a and 14b. Referring to Figs. 1-2, for the purposes of the instant disclosure, the circumferential direction of the scaffold is indicated by
20 arrow A and generally extends along the middle section of the scaffold.

Referring to Fig. 3a, in operation, a compressive force F would normally be applied on the scaffold 10 in axial direction, which is indicated by an arrow F. Referring to
25 Fig. 3b, the design of the implant is such that the compressive force F on the scaffold 10 is translated into tensile hoop stresses in circumferential direction, as shown by arrows F_h . For consistency, the same terminology is also applied in reference to the reinforcing matrix and the
30 implant as a whole.

Referring back to Fig. 1, the reinforcing matrix 20 may be formed by at least one fiber 23 extending between the anterior end 11 and posterior end 12 of the scaffold 10 and exiting each end to form an anterior attachment point 21 and a posterior attachment point 22. As used herein, the term "fiber" refers to any generally elongated member consisting of a single component, e.g. monofilament suture, or multiple components, e.g. multifilament suture. The fibers may be formed by any suitable method for forming the biocompatible materials from which they are made into a fiber or filament. The fibers may be drawn, extruded, cast, etc. The physical property of the fiber, such as tensile strength, cross-sectional area, diameter, flexibility, etc, may vary over the length of the fiber. In some embodiments, multiple fibers may be used to form the reinforcing matrix. The fibers may be made of the same or different materials and may follow the same or different paths.

Preferably, at least a portion of the fiber 21 forming the reinforcing matrix 20 is positioned substantially in circumferential direction 24. In some embodiments, the fiber 23 forming the reinforcing matrix 20 may be arranged in two different arrangements: the circumferential arrangement 24 and an orthogonal arrangement 25. As used herein, the terms "orthogonal arrangement," or "arranged orthogonally," means an arrangement of fibers extending in directions substantially parallel to arrows B in Fig. 2 at various angles in relation to the scaffold.

In reference to Fig. 4, the reinforcing matrix 20 comprises one or more circumferential fibers 24 and one or more orthogonal fibers 25. The term "circumferential fiber" refers to fiber that extends between the anterior end and posterior end of the scaffold along the middle section of

the scaffold and is positioned at least in part substantially parallel to the circumferential axis. The term "orthogonal fiber" refers to fibers that cross the circumferential fibers at various angles to keep them from separating. Keeping the circumferential fibers from separating increases the durability and longevity of the implant. For convenience, terms "circumferential fiber network" and "orthogonal fiber network" may be used herein to refer to multiple circumferential fibers or multiple orthogonal fibers, respectively.

As noted above, in operation the compressive force on the device in the axial direction is translated into tensile hoop stresses in the circumferential direction. The hoop stresses propagate along the circumferential fibers. In vivo, as meniscal tissue grows into the implant and cells attach to the fiber networks, cells on or about the circumferential fibers experience the same mechanical environment as in a normal meniscus, resulting in the formation of tissue with the essentially the same organization and directionality of collagen fibers as the original meniscus.

The reinforcing matrix may be formed with one single continuous fiber arranged both circumferentially and orthogonally, or, the matrix may be formed using multiple fibers. In such embodiments, the circumferential fibers as well as orthogonal fibers may be formed by the same or different strands of fiber or a combination thereof.

The instant implant includes an anterior attachment point 21 and a posterior attachment point 22 for attaching the implant to tissue adjacent to the implantation site. These attachment points are formed by fiber exiting from the anterior and posterior end of the scaffold, respectively.

Referring to Figs. 3a-3b, attaching the implant in place by these attachment points converts axial compressive force F on the scaffold 10 and reinforcing matrix 20 into tensile loads along the circumferential fibers and on the anterior and posterior attachment points. The forces on the anterior and posterior attachment points are presented as force F_a and force F_p , respectively.

Moreover, in some embodiments, the implant may comprise one or more additional attachment points 30 formed in the middle section of the scaffold, preferably on the exterior periphery of the middle section. Such attachment points are referred to as peripheral attachment points. In suitable embodiments, peripheral attachment points preferably coincide with points at which orthogonal fibers cross circumferential fibers.

As noted above, intervertebral discs or temporomandibular joint discs function as load transmitters and distributors to prevent high-stress bone-on-bone contact. For example an intervertebral disc comprises the annulus fibrosus and the nucleus pulposus. The nucleus pulposus is the inner gelatinous material surrounded by the annulus fibrosus. It distributes mechanical loads placed upon the disc, while the annulus fibrosus provides structural integrity and constrains the nucleus pulposus to a specific spinal region.

The annulus fibrosus has an internal structure which is very similar to the internal structure of meniscal tissue. Accordingly, torroidal concepts herein described may be utilized to construct implants for full or partial replacement of annulus fibrosus.

Referring to Fig. 5a, in one embodiment the instant implant 50 may comprise a torroidal-shaped scaffold 51 and a reinforcing matrix 52. The reinforcing matrix 52 may be constructed as is described above in reference to meniscus implants. In preferred embodiments, the reinforcing matrix comprises circumferential fibers 53 and orthogonal fibers 54 that cross the circumferential fibers to prevent separation of the circumferential fibers. However, in contrast to embodiments described above, the fibers forming the reinforcing matrix do not exit the scaffold and the implant may be secured by attaching the implant to the healthy tissues at peripheral attachment points 55. A device in the process of being wound is depicted in Figs. 5b and 5c.

According to one torroidal embodiment, torroidal implants may be fabricated in the shape of a vertebral disc, wherein the torroidal-shaped scaffold defines an interior cavity filled with a biocompatible material with physical properties equivalent to the properties of the nucleus pulposus of a patient's vertebral disc. Materials suitable for use as nucleus pulposus are known and are disclosed, for example, in U.S. Patent Nos 5,976,186; 7,004,971 and 7,214,245, all of which are incorporated herein by reference in their entirety. Alternatively, the implant is configured to replace only the annulus fibrosus or a part of the annulus fibrosus.

For both the arcuate and torroidal constructs, both the scaffold and the reinforcing circumferential and orthogonal matrix fibers may be constructed of naturally-occurring or synthetic biocompatible materials or a combination thereof so to enable infiltration, attachment and proliferation of cells from surrounding tissues once the implant is in place. The naturally-occurring or synthetic biocompatible materials may also be bioresorbable. The scaffold and the reinforcing

matrix fibers may be constructed from the same material or different materials and may be fully or partially biodegradable and may have the same or different rate of degradation.

As used herein the term "synthetic polymer" refers to
5 polymers that are not found in nature, even if the polymers
are made from naturally occurring biomaterials. The term
"natural polymer" refers to polymers that are naturally
occurring. The term "biocompatible" refers to materials that,
in the amounts employed, do not elicit a detrimental
10 response in the host. This term is intended to include
materials that may cause some inflammation, tissue necrosis
or other immune responses when introduced into the host,
provided that these effects do not rise to the level of
pathogenesis. The term "bioresorbable" refers to those
15 materials that when placed in a living body at standard
physiological conditions are degraded through either
enzymatic, hydrolytic or other chemical reactions or
cellular processes into by-products that are either
integrated into or expelled from the body. It is recognized
20 that in the literature, the terms "bioresorbable,"
"resorbable", "absorbable", "bioabsorbable" and "biodegrad-
able" are frequently used interchangeably and such inter-
changeable meaning is intended for the present application.

In preferred embodiments, the implant is formed from
25 biodegradable material or materials. The polymers for the
instant implant are selected so the implant possesses
mechanical properties which are the same or substantially
similar to the mechanical properties of the native tissue
being replaced. Moreover, as shown in Fig. 6, it is
30 desirable for the mechanical properties of the implant to
remain consistent as the implant is being remodeled.
Accordingly, the polymers are selected so their degradation

profile closely matches neo-tissue formation and remodeling, so the new tissue is afforded sufficient time to gain enough strength to compensate for the decrease in strength of the polymers. As shown in Fig. 6, this ensures that at all
5 times the implant possesses mechanical properties resembling those of native tissue, which allows the implant to assume loads experienced in the joint at all times without failure.

Examples of suitable natural polymers include, but are not limited to, collagen, hyaluronic acid, fibrin glue, bone
10 marrow, chitosan, alginates, celluloses, starches, silk, elastin, and other animal- or plant-derived proteins or polysaccharides. Suitable synthetic polymers include, but are not limited to, poly(alpha-hydroxy acids), poly(lactide-co-glycolide) (PLGA), poly(L-lactides) (PLLA), polylactides
15 (PLA), polyglycolides (PGA); polyethylene, polypropylene, polyvinyl alcohol (PVA), polyethylene oxide (PEO); poly-p-dioxanone (PDO); polyarylates, polyacrylates, polycarbonates, polyesters, polycaprolactone (PCL) and combinations thereof. Suitable polyarylates and polycarbonates include, but are
20 not limited to the tyrosine-derived polyarylates and polycarbonates disclosed by US Patent Nos. 5,099,060; 5,198,507; 5,216,115; 5,587,507; 5,658,995 and 6,048,521, the disclosures of all of which are incorporated herein by reference.

In preferred embodiments, the scaffold is an amorphous
25 structure composed primarily of Type I collagen. In addition to collagen, other types of materials may be added to alter the scaffold's properties as necessary or desired. For example, other proteins or proteoglycans may be used, including, but not limited to, glycosaminoglycans such as
30 chondroitin sulfate, keratan sulfate, dermatan sulfate, heparin, heparin sulfate and hyaluronic acid. The percentage of these materials in the scaffold may range between 0 and

about 20% of the dry weight of the scaffold. The fiber for the reinforcing matrix may preferably be made from a bioresorbable synthetic polymer, such as a polyarylate, or a non-synthetic material, such as collagen.

5 The physical characteristics of the implant may be modified by using different materials for the scaffold and/or forming the reinforcing matrix from fibers of different diameter, mechanical strength, stiffness, or durability. Moreover, the physical characteristics of the
10 implant may be modified by cross-linking the scaffold, the reinforcing matrix or both. Cross-linking may be achieved by employing a variety of known methods, including, but not limited to, chemical reaction with a carbodiimide, glutaraldehyde or formaldehyde among others; the application of
15 energy such as radiant energy, which includes irradiation by UV light or microwave energy; dehydrothermal treatment in which water is slowly removed while the bone tissue is subjected to a vacuum; and, enzymatic treatment.

 The instant implant may act as a carrier for various
20 medical agents such as therapeutic agents and biologic factors that promote the in-growth and repair of fibrocartilage tissues and vasculature networks, and the attachment of bone tissue, where needed, including various growth factors. Suitable therapeutic agents may be selected
25 from anti-inflammatory agents, antibiotic agents, immunosuppressive or immunomodulator agents, analgesics, antiapoptotic agents, or combinations thereof. Small molecule therapeutics may form part of the polymer backbone of synthetic scaffold polymers, one example of which is
30 polyaspirin, or the small molecule therapeutics may be supplied as covalent pendant polymer attachments.

The biologic factors or therapeutic agents may elute or be released from the implant as the implant degrades in the event of a bioabsorbable or a partially bioresorbable implant. Prior to elution or release by degradation, and in
5 some embodiments that do not degrade, the biological factor or therapeutic agent is expressed on a device at the polymer surface without release. Alternatively, the implant may include additional components, such as coating or embedded bioresorbable matrices loaded with the biologic factors or
10 therapeutic agents.

In addition, instant implants may be populated with cells of the type typically found in the type of tissue to be replaced or that can differentiate into such type of cells. By way of a non-limiting example, the instant
15 implants may be seeded with fibroblasts, chondrocytes or mesenchymal stem cells. The mesenchymal stem cells may be derived from essentially any stem cell source, including, but not limited to bone marrow, umbilical cord blood, muscle tissue, skeletal tissue, embryonic tissue, etc. The cells
20 may be added to the implant immediately prior to insertion of the implant into the patient's body or may be grown on the implant in the days or weeks prior to implantation. Alternatively, cells may be delivered to the implant after implantation. Techniques for preparing implants populated
25 with cells are known in the art and are disclosed for example in U.S. Patent No. 6,103,255, the disclosure of which are incorporated herein by reference.

Moreover, the instant implant may include radio-opaque, echogenic materials and magnetic resonance imaging (MRI)
30 responsive materials (i.e., MRI contrast agents) to aid in visualization of the implant under ultrasound, fluoroscopy and/or MRI. For example, a device may be made with or coated

with a composition which is echogenic or radiopaque (e.g., made with echogenic or radiopaque with materials) or, by the addition of microspheres or bubbles which present an acoustic interface). For visualization under MRI, contrast
5 agents may be incorporated into or onto the implant. In some embodiments, the instant implant may include radio-opaque or MRI visible markers.

The instant implants may, alternatively, or in addition, be visualized under visible light, using
10 fluorescence, or by other spectroscopic means. Visualization agents that can be included for this purpose include dyes, pigments, and other colored agents. In one aspect, the instant implant may further include a colorant to improve visualization of the implant in vivo and/or ex vivo.
15 Frequently, implants can be difficult to visualize upon insertion, especially at the margins of implant. A coloring agent can be incorporated into the instant implant to reduce or eliminate the incidence or severity of this problem. The coloring agent provides a unique color, increased contrast,
20 or unique fluorescence characteristics to the implant so it is readily visible (under visible light or using a fluorescence technique) and easily differentiated from its implant site.

In another aspect, a method for implantation of the
25 instant implant in place of a damaged tissue is provided. The instant devices may be implanted by surgical or arthroscopic techniques. In general, to implant the instant device the tissue in need of replacement is removed, the implant is inserted to replace the removed tissue and is
30 fixed in place to tissue adjacent the implantation site, for example, by suturing. When a compressive force is applied to the instant implant after implantation, the force is

converted into tensile loads along circumferential fibers in the reinforcing matrix.

By way of non-limiting example, the instant implant is particularly useful for treatment of anatomical variances in meniscus, such as tears or discoid meniscus. The instant
5 implant may be used in partial, sub-total, or total meniscectomy. The damaged meniscal tissue, representing a total or part of a meniscus, is removed and the instant implant, tailored to have the same size and shape as the
10 removed tissue, is placed in its place.

In total or subtotal meniscectomy, the implant is secured in place by attaching the anterior and posterior attachment points of the implant to the tibial plateau. One or more holes may be drilled in the tibial plateau,
15 preferably, at the site of the anterior and posterior attachments of the original meniscus. The anterior and posterior attachment points may be inserted into these holes and secured in place by any known techniques, such as using
20 metal or polymeric interference screws, pressure fitting, stapling, suturing, and so forth. Such tibial attachments enable generation of hoop stresses in the implant.

In addition, the implant may be further secured in place by suturing it to healthy tissue adjacent to the implantation site, namely the joint capsule, cartilage, or
25 remaining meniscal tissue, at one or more peripheral attachment points in the middle section of the scaffold. In a partial meniscectomy, the meniscus may be secured in place exclusively at one or more peripheral attachment points in addition to being sutured to the remaining meniscus tissue.

In yet another aspect, a method for fabrication of the instant device is provided. First, the reinforcing matrix is formed from one or more fibers, preferably in a shape of the soft tissue the implant is designed to replace. The
5 matrix may be formed by any method known and used in the art for physically interlacing fibers, such as, without limitation, weaving, braiding, knitting, or combination thereof. Alternatively, the fibers may be attached using chemical means such as gluing or cross-linking the fibers together.
10 Moreover, a polymer may be molded into the shape of a three-dimensional matrix.

Second, the reinforcing matrix is inserted into a mold assembly or a mold assembly is formed around the matrix. The mold preferably has the same shape as the soft tissue in
15 need of replacement. In some embodiments, the ends of the fiber forming the reinforcing matrix extend outside each end of the mold assembly to form the attachment points. Third the polymer is injected into the mold assembly to form the scaffold body, which is then solidified.

20 The process for solidifying the scaffold depends on the polymer used to form the scaffold. For example, if collagen is used, the implant assembly may be lyophilized. In some embodiments, the implant may be cross-linked to alter its physical characteristics. Moreover, additives such as cells,
25 growth factors, medical agents, and/or labels, etc., may be added to the implant at any point during the fabrication of the device according to standard techniques known and used in the field.

As noted above, in some embodiments both the fiber
30 network matrix and the scaffold have same the shape and

geometry as the soft tissue they are made to replace. For example, in embodiments for the knee, the reinforcing matrix and the mold assembly may be constructed as a c-shaped disc with a wedge-like cross-section, similar to a knee meniscus.

5

EXAMPLES

Example I: Fabrication of Meniscus implant

The mold for the scaffold was made up of a plastic base plate, outer glass tube, inner sphere, and 24 clothing pins. Twenty-four holes (0.05 mm) were drilled through the large face of the plate as shown in Fig. 7a. Twenty-two holes were at equal intervals forming a semi-circle with the remaining two holes opposite the center of the semi-circle. Twenty-four pins were pushed through the holes forming the pattern shown in Fig. 7b. For purposes of explanation, each hole of the base plate was assigned a number from 1 through 26. Holes 2 through 25 define the actual dimensions of the meniscus scaffold, while holes 1 and 26 define the anchor points for the scaffold.

Referring to Figs. 8a-8g, a continuous length of polymer fiber was wrapped around the pins in a quasi-circumferential pattern. Starting from point 1, fibers were wrapped and pivoted at one of six different off-tangent angles from the pins: (a) 11.25° , (b) 28.125° , (c) 39.375° , (d) 50.625° , (e) 61.875° , and (f) 73.125° . This continued until point 26, at which time the fiber was wrapped in reverse. For pins 2 through 5 and 22 through 25, fibers were wrapped back to point 1 or 26 for formation of anchor bundles. This process was repeated for each angle to produce a complete pattern shown in Fig. 8g. Depending on the amount of fiber desired for reinforcing, this pattern was repeated several times.

The pin pattern allows for a semi-lunar shape to be formed along with two bundles of fibers at each horn for formation of the anchor plugs. After wrapping was complete, the fibers were teased up to form a wedge shape (cross-section). The fiber wrapped assembly was then stored in a low humidity chamber until the collagen dispersion was ready for the molding step.

A collagen dispersion was made by swelling lyophilized type I bovine collagen in an acid solution (pH ~2.4). The appropriate amount of collagen was added to a volume of acid (e.g. for 1% dispersion, 1.0 g collagen added to 100 ml acid). As noted above, in different embodiments, other materials may be added to alter the properties of the matrix portion and dispersion concentrations may be modified. The collagen/acid mixture was then homogenized using a high speed blender (pulse blending to reduce possible heat denaturation effects on collagen). After about five minutes of pulse blending (mix ~5 seconds, wait for ~1 minute), the mixture was de-aerated under vacuum for about five minutes. About 8 ml of the dispersion was drawn up into a syringe using a 20 gauge needle to prevent large, non-homogenized chunks of collagen from entering scaffold.

The outer glass tube and inner sphere were placed in position around the base plate to complete the mold assembly. The collagen dispersion was injected into the mold, ensuring no air bubbles were introduced into the scaffold body. The assembly was wrapped in a thin plastic bag and submerged in an ethanol-dry ice bath (~ -30 °C) for about 10 minutes. The resultant solid was then transferred to a standard freezer for about an hour to ensure complete

freezing. After the entire assembly was frozen completely, it was lyophilized.

After lyophilization, the pins were pulled from the base plate, resulting in a fiber reinforced collagen sponge with a semi-lunar shape, a wedge-shaped cross-section, and a series of small holes around its periphery. The extra lengths of fibers from the ends of the scaffold were used to form anchor plugs which can be implanted into the tibial plateau. A medical grade polyurethane adhesive was used to form the plugs. The ends of the fiber bundles were dipped in the adhesive and formed into a bullet-shaped plug.

After construction, the scaffolds were crosslinked to increase the durability of the collagen matrix. The implant was stored dry until use.

15

Example 2: Mechanical Evaluation

A preliminary mechanical evaluation was carried out using standard tensile testing. The following four groups were tests: no scaffold, collagen scaffold without reinforcement ("100 Coll. Scaffold), collagen scaffold with a reinforcing fibers consisting of 500 fibers ("500 Fiber Scaffold"), and collagen scaffold with a reinforcing fibers consisting of 1000 fibers ("1000 Fiber Scaffold). In this evaluation the anterior and posterior fiber ends were soaked in poly-urethane glue and dried overnight. They were then loaded into an Instron Mechanical Tester (model 4202) and pulled in tension until failure at a speed of 10 mm/min. The structural properties were calculated from recorded data. The results are set forth in Fig. 9.

25

An advanced mechanical evaluation of the meniscus replacement of the invention measured pressure distribution on the tibial plateau but did not measure circumferential hoop stresses developed from axial compressive loads using
5 "indirect" measurement. The results are shown in Figs. 10-13. With regard to the contact area, no significant difference was seen between the "No Scaffold" and "100% Coll. Scaffold" groups while there were significant differences between "No Scaffold" and "100% Coll. Scaffold" groups and
10 "500 Fiber Scaffold" and "1000 Fiber Scaffold" groups.

Example 3: Biological Evaluation

The scaffold was evaluated by characterizing the *in vitro* biological response to the scaffold as well as
15 preliminary *in vivo* evaluations in rabbit models.

In an *in vitro* evaluation a fibrochondrocyte cell line was harvested from NZW rabbits and cultured until 2nd/3rd passage. Scaffolds were sectioned into 6 wedges as shown in Fig. 14a. 1×10^5 cells were seeded onto the anterior surface
20 of each section and the cell-seeded scaffolds were incubated in complete cell media for 4 hrs, 4 days, 8 days, or 16 days. The scaffolds were then analyzed with either MTS assay or standard H&E histology. A normal growth curve was observed with a significant difference between all time
25 points, as seen in Fig. 14b. There was no significant difference between the two scaffold types of the invention.

In a non-functional *in vivo* evaluation in rabbits, two sections were cut from each scaffold for 4 and 8 week time points. Two scaffold designs were studied (500 fiber and
30 1,000 fiber scaffolds). A medial parapatellar arthrotomy

created a pocket for an implant between medial joint capsule and medial femoral condyle and the scaffold was inserted. The scaffold therefore was exposed to harsh synovial environments but was under no significant load and did not
5 interfere with joint function. Both knees of each rabbit were used with the 500 fiber scaffold on one side and the 1000 fiber scaffold in the other. At sacrifice the scaffolds were excised along with 2 - 3 mm of surrounding tissue. The samples were preserved in buffered formalin and then
10 processed histologically with H&E stain. The results are shown in Figs. 15a-15f.

Although the invention herein has been described with reference to particular embodiments, it is to be understood that these embodiments are merely illustrative of the
15 principles and applications of the present invention. It is therefore to be understood that numerous modifications may be made to the illustrative embodiments and that other arrangements may be devised without departing from the spirit and scope of the present invention which is defined
20 by the following claims.

CLAIMS

What is claimed is:

1. An artificial fibrocartilage implant comprising:
5 an arcuate or torroidal scaffold;
a circumferential fiber network embedded in said scaffold;
and

an orthogonal fiber network embedded in said scaffold to prevent separation of said circumferential fiber network;

10 wherein said fiber networks convert an axial compressive force on said scaffold to tensile loads along the circumferential fiber network.

2. The implant of claim 1, wherein the scaffold is an arcuate scaffold comprising an anterior end, a posterior end
15 and a middle section therebetween defining a curved path between said anterior and posterior ends.

3. The implant of claim 2, wherein the circumferential fiber network extends between said anterior and posterior ends along the path of said curve and exits the anterior and
20 posterior ends of the scaffold to form respective anterior and posterior attachment points.

4. The artificial implant of any one of claim 2 or claim 3, wherein said implant is fabricated in the shape of a knee meniscus.

25 5. An artificial knee meniscus implant comprising:
a c-shaped scaffold having an arcuate middle section extending between an anterior end and a posterior end; and

a reinforcing fiber network embedded in the scaffold;

wherein the fibers of said network exit each end of the scaffold to form respective anterior and posterior attachment points and said fiber network converts an axial compressive force on said scaffold to tensile loads on said attachment points.

6. The artificial meniscus of claim 5, wherein at least a portion said fiber network extends along said arcuate middle section in a substantially circumferential direction.

10 7. The artificial meniscus of claim 6, wherein said fiber network further comprises an orthogonal fiber network embedded within said scaffold to prevent separation of said circumferential fiber network.

15 8. The artificial implant of claim 1 or claim 5, wherein the scaffold has a wedge-shaped cross-section.

9. The artificial implant of claim 1 or claim 6, further comprising at least one peripheral attachment point.

20 10. The artificial implant of claim 9, wherein the at least one peripheral attachment point coincides with a point at which said circumferential fiber network intersects with said orthogonal fiber network.

11. The artificial implant of claim 8, wherein the reinforcing matrix extends throughout said wedge-shaped cross section of said arcuate middle section.

25 12. A method for replacement of a damaged meniscus comprising replacing the damaged portion of said meniscus with an implant according to claim 4 or claim 5 corresponding to the damaged portion being replaced by inserting said

implant between the tibial plateau and the corresponding femur condyle.

13. The method of claim 12, wherein said method comprises a total or sub-total meniscectomy and said method
5 further includes the step of securing said attachment points to corresponding anterior and posterior anchor plugs inserted into said tibial plateau.

14. The method of claim 13, wherein said implant further comprises at least one additional attachment point
10 on the exterior periphery of said arc-shaped the middle section and said method further comprises the step of attaching the implant to the surrounding tissue wall through at least of said additional attachment points.

15. The method of claim 14, wherein at least one additional attachment point coincides with a point at which a fiber extending circumferentially along said arc-shaped middle section contacts said exterior periphery of said arc-shaped middle.

16. The method of claim 12, wherein the scaffold is
20 formed from a material selected from the group consisting of proteins, proteoglycans, biocompatible synthetic polymers and combinations thereof.

17. The method of claim 16, wherein said material is bioresorbable.

25 18. The method of claim 16, wherein the proteins comprise collagen.

19. The method of claim 18, wherein the collagen is cross-linked.

20. The method of claim 12, wherein at least one of the scaffold, the circumferential fiber network or the orthogonal fiber network comprises a biocompatible synthetic polymeric material.

5 21. The method of claim 20, where said polymeric material is bioresorbable.

22. A method for fabricating a soft tissue repair implant, the method comprising:

forming a reinforcing fiber network characterized by a
10 matrix comprising at least one fiber; and

embedding the reinforcement matrix into a scaffold, wherein the scaffold has an arcuate middle section extending between an anterior end and a posterior end; and wherein the at least one fiber exits each end of the scaffold.

15 23. The method of claim 22, wherein the network comprises a circumferential fiber network and an orthogonal fiber network that prevents separation of the circumferential fiber network.

20 24. The method of claims 22 or 23, wherein the scaffold comprises an anterior end, a posterior end and a middle section therebetween defining a curved path between said anterior and posterior ends.

25 25. The method of claim 24, wherein the circumferential fiber network extends between said anterior and posterior ends along the path of said curve and exits the anterior and posterior ends of the scaffold to form respective anterior and posterior attachment points.

26. An artificial implant comprising:
a torroidal-shaped scaffold;

a circumferential fiber network embedded in said scaffold;
and

an orthogonal fiber network embedded within said scaffold
to prevent separation of said circumferential fiber network;

5 wherein said fiber networks convert an axial compressive
force on said scaffold to tensile loads along the circumfer-
ential fiber network.

27. The artificial implant of claim 26, wherein said
implant is fabricated in the shape of a vertebral disc or an
10 articular disc for a joint.

28. The artificial implant of claim 26 or 27 further
comprising at least one peripheral attachment point.

29. The artificial implant of any one of claims 26-28,
wherein the at least one peripheral attachment point
15 coincides with a point at which said circumferential fiber
network intersects with said orthogonal fiber network.

30. The artificial implant of claim 27, characterized by
being fabricated in the shape of a vertebral disc, wherein
the torroidal-shaped scaffold defines an interior cavity
20 filled with a biocompatible material with physical
properties equivalent to the properties of the nucleus
pulposus of a human vertebral disc.

31. The artificial implant of claim 27, characterized
by being an articular disc for the temporomandibular joint
25 or the wrist.

32. The artificial implant of any one of claim 1,
claim 5, claim 30 or claim 31, wherein the scaffold is
formed from a material selected from the group consisting of

proteins, proteoglycans, biocompatible synthetic polymers and combinations thereof.

33. The method of claim 32, wherein said material is bioresorbable.

5 34. The method of claim 32, wherein the proteins comprise collagen.

35. The method of claim 34, wherein the collagen is cross-linked.

10 36. The artificial implant of any one of claim 1, claim 7, claim 30 or claim 31 wherein at least one of the scaffold, the circumferential fiber network or the orthogonal fiber network comprises a biocompatible synthetic polymeric material.

15 37. The method of claim 36, where said polymeric material is bioresorbable.

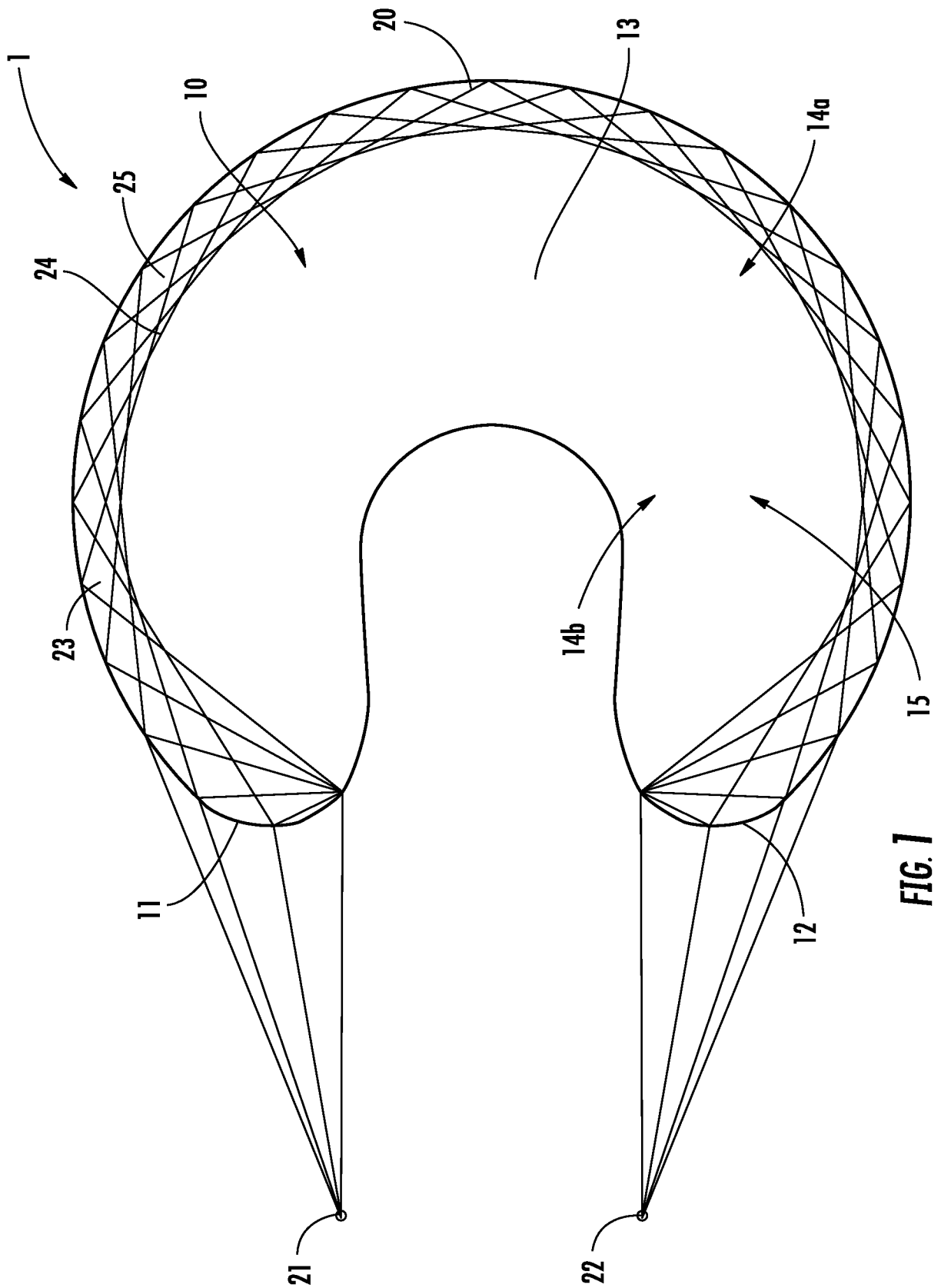

FIG. 1

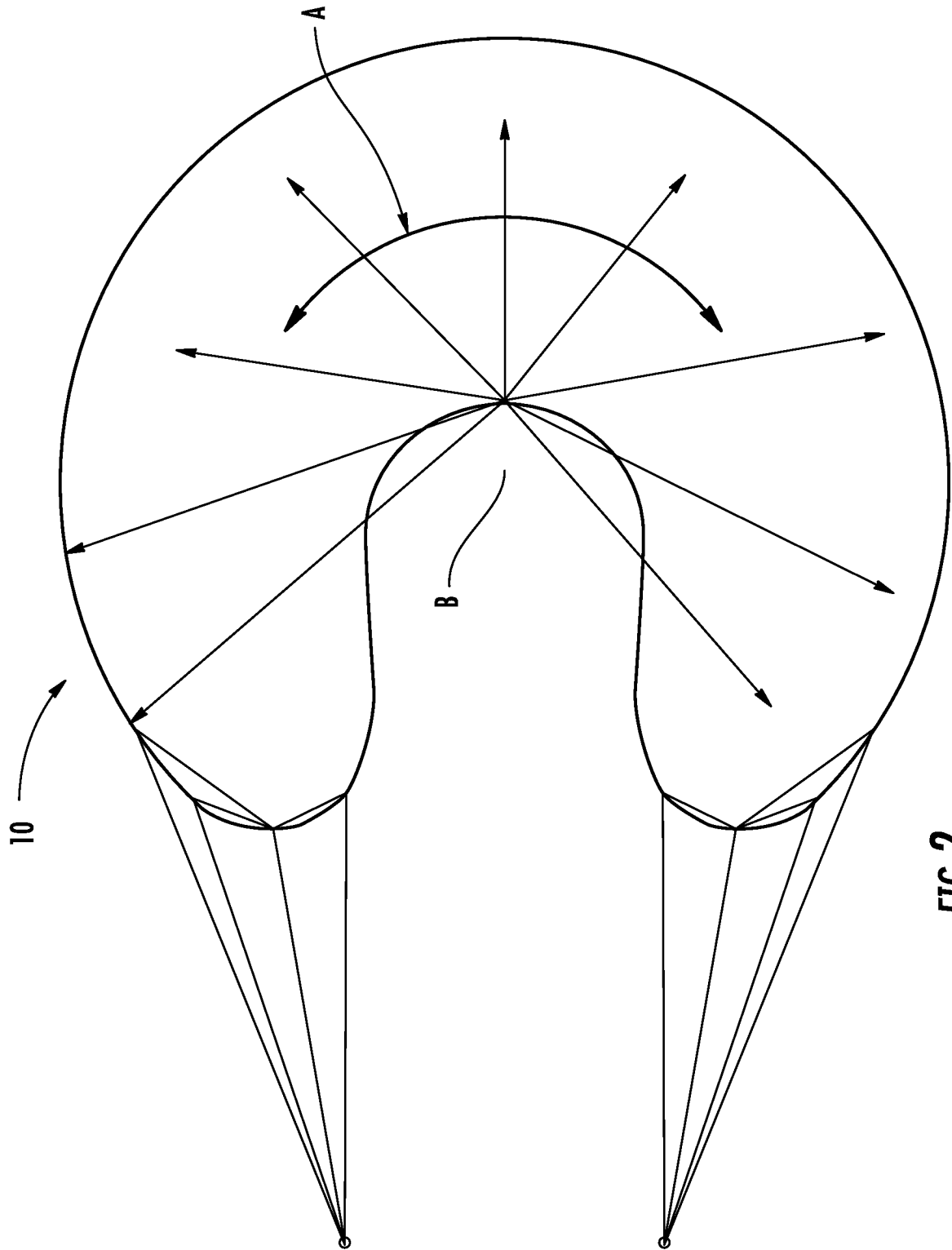

FIG. 2

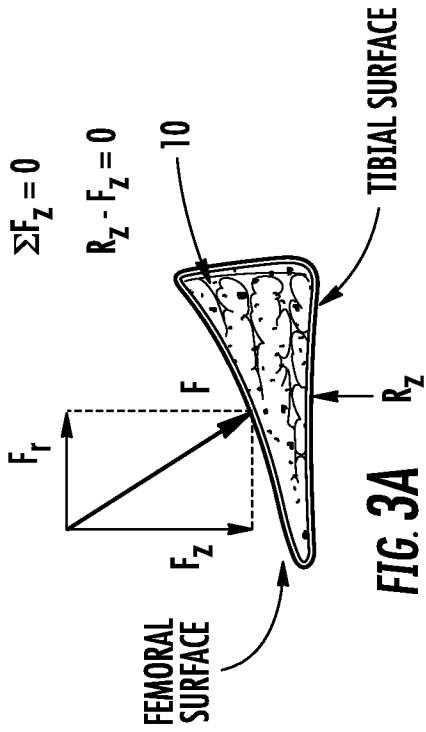

FIG. 3A

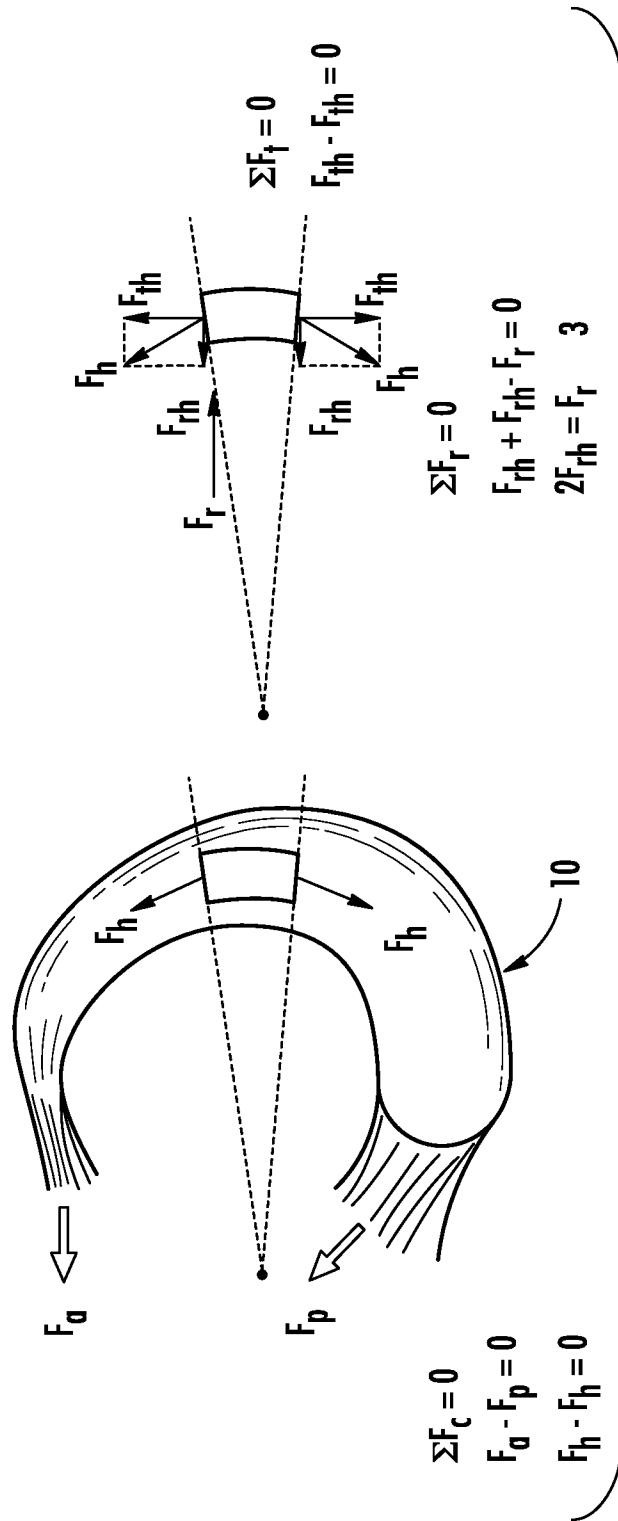

FIG. 3B

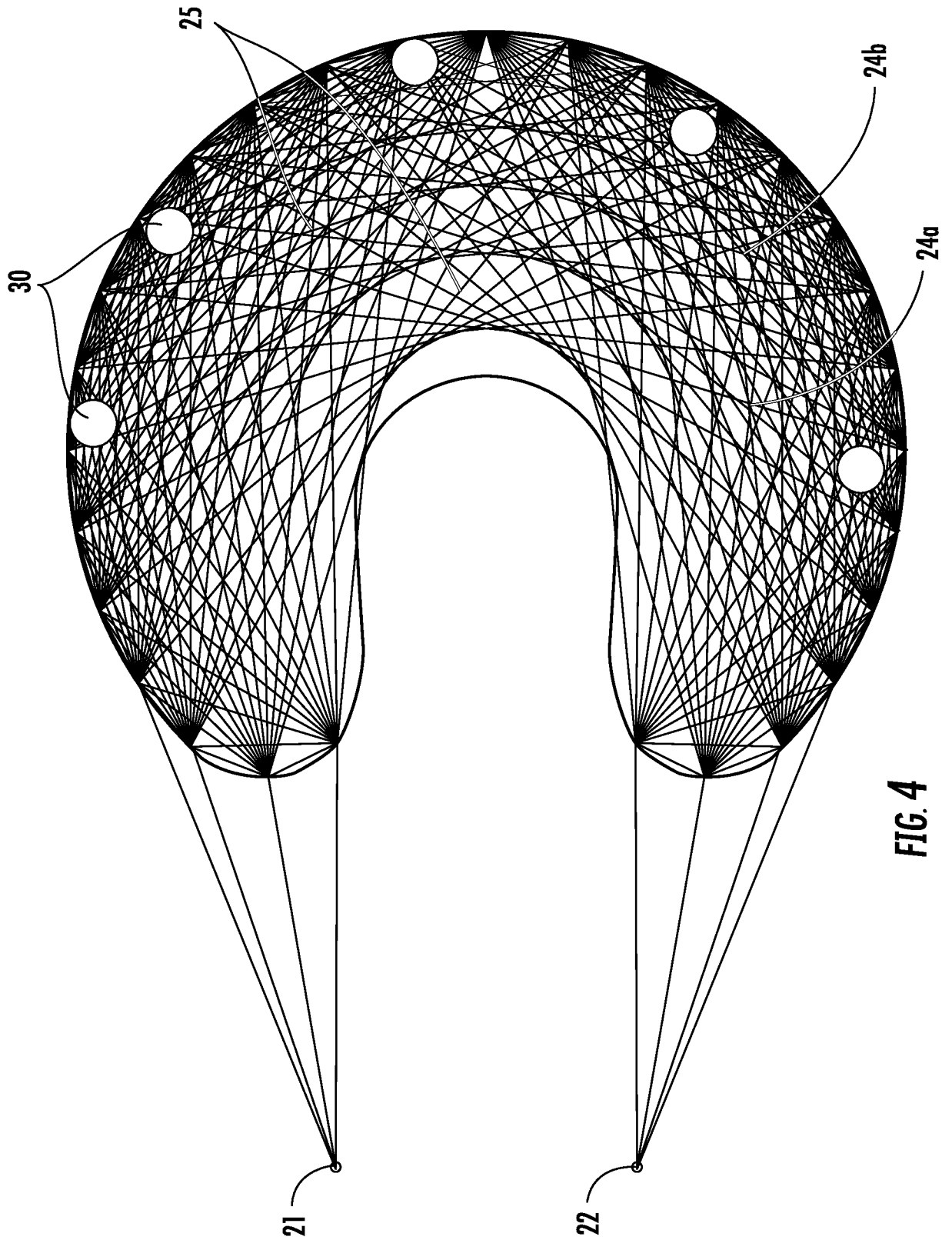

FIG. 4

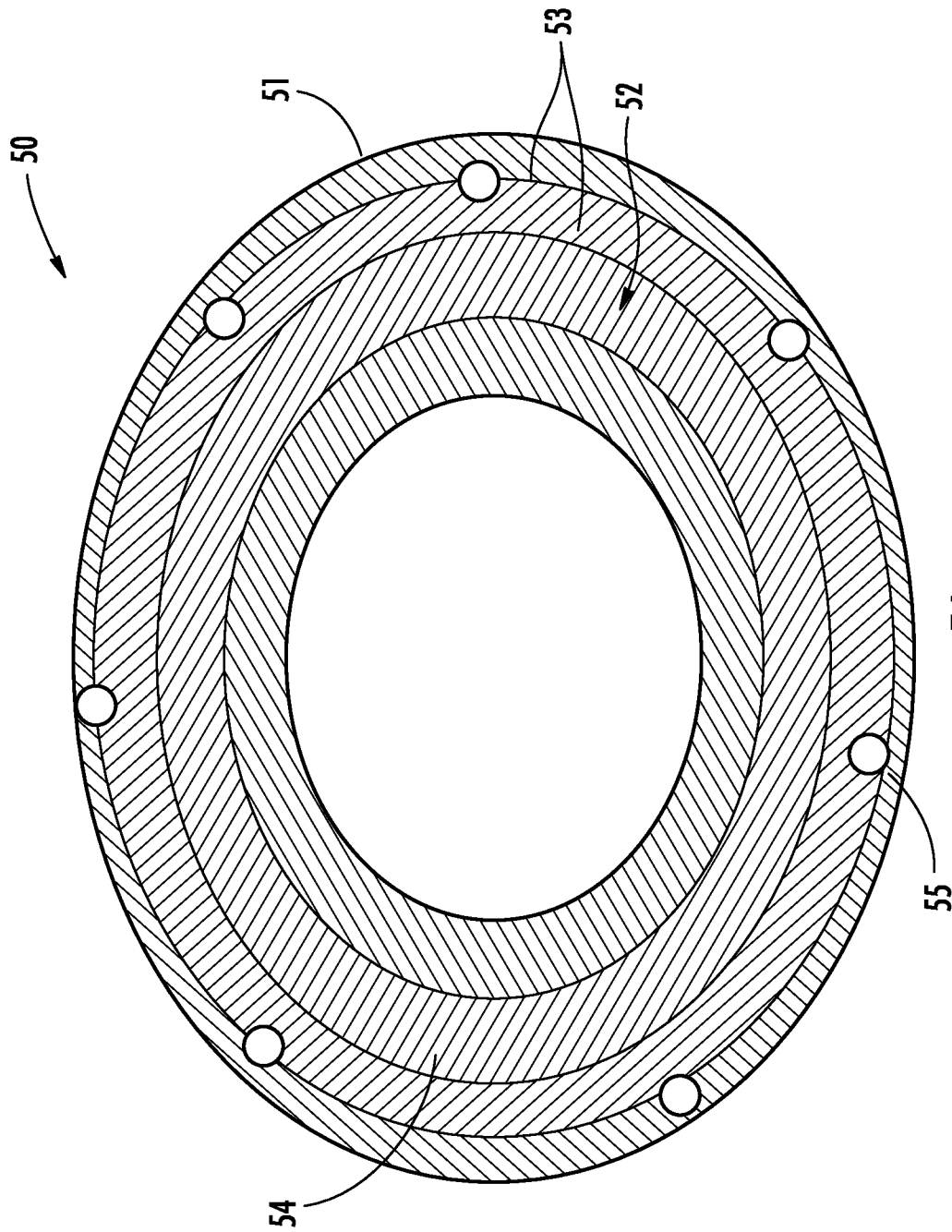

FIG. 5A

6/21

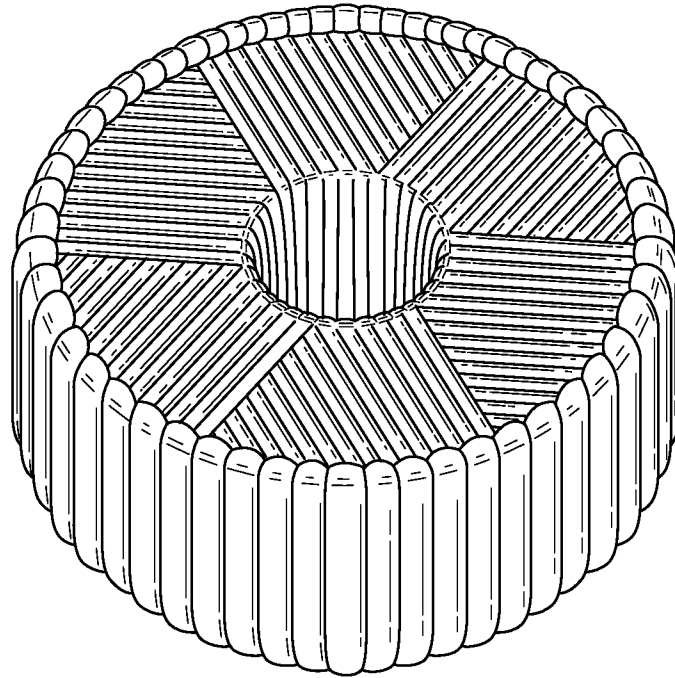

FIG. 5B

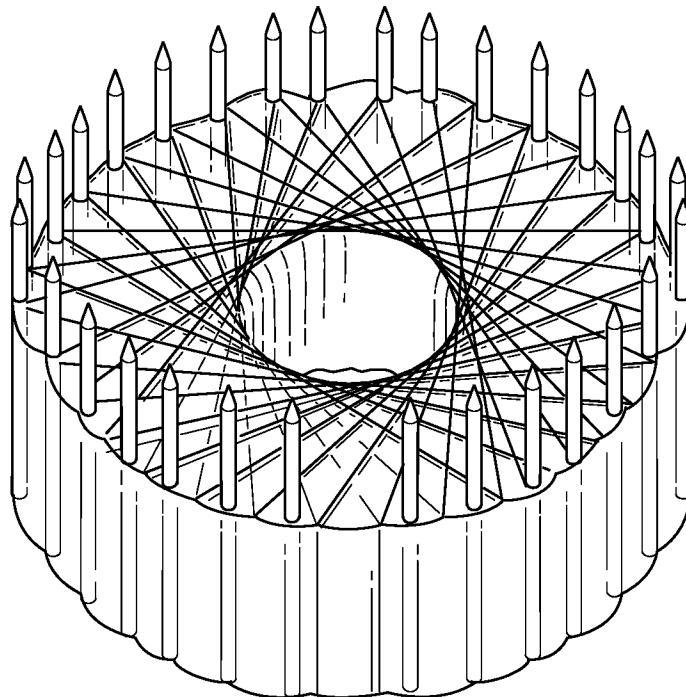

FIG. 5C

7/21

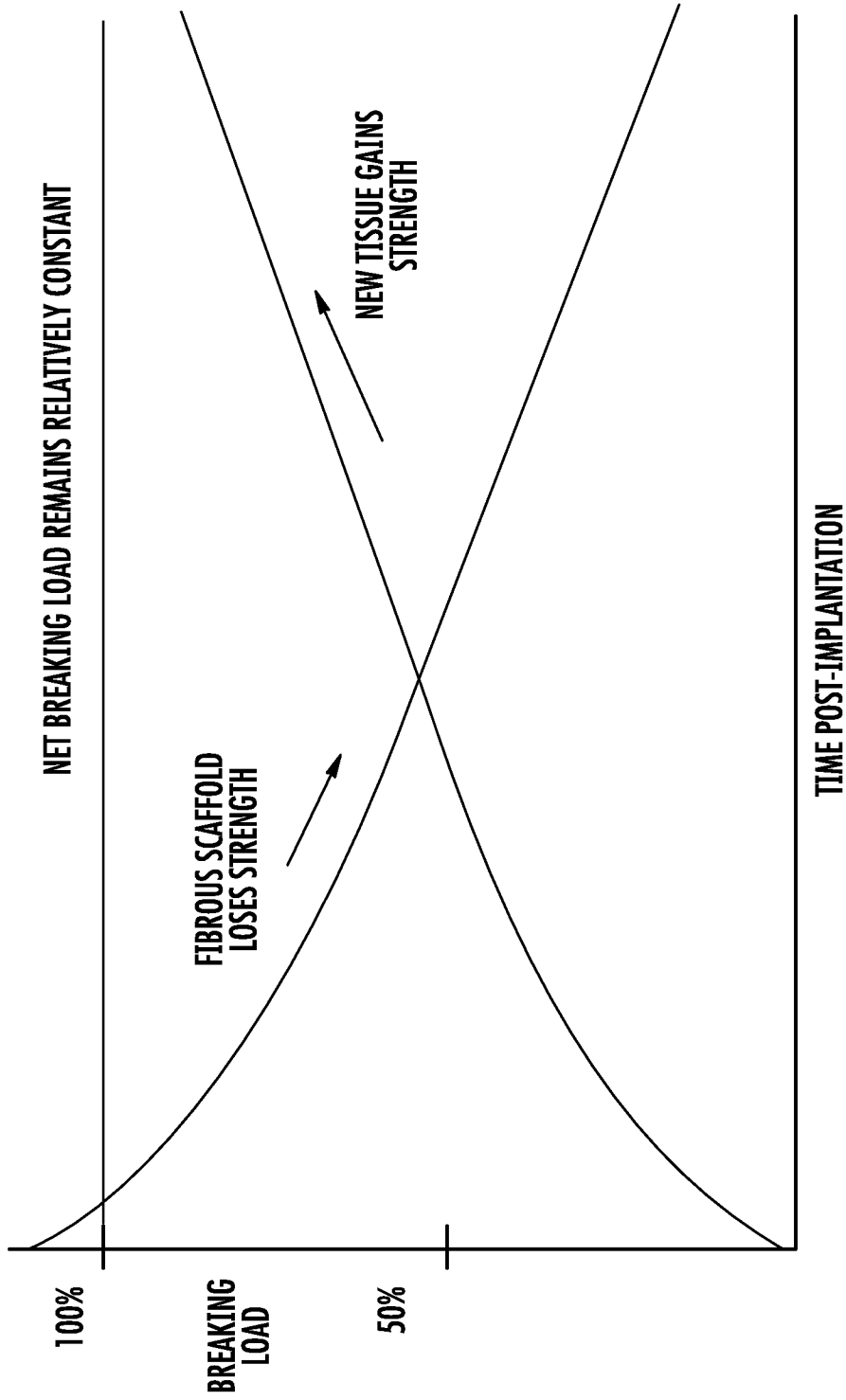

FIG. 6

8/21

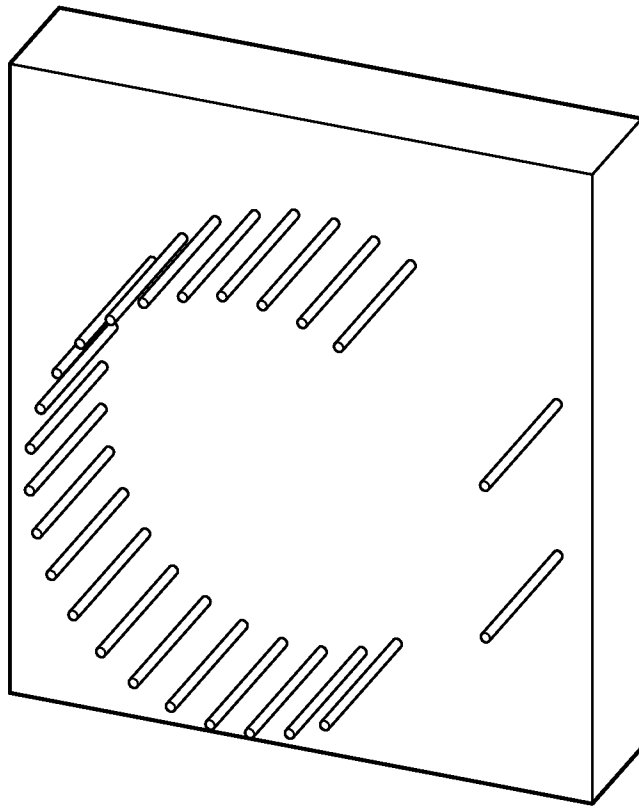

FIG. 7B

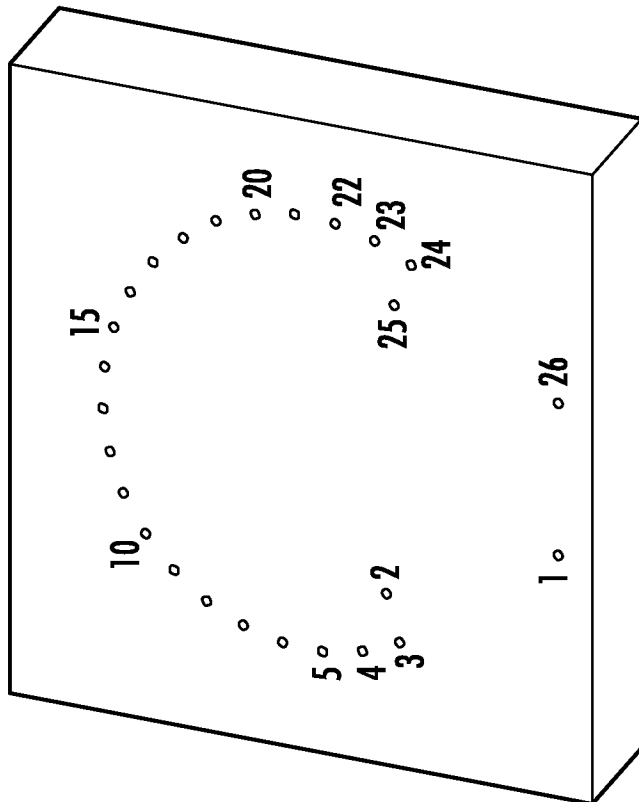

FIG. 7A

9/21

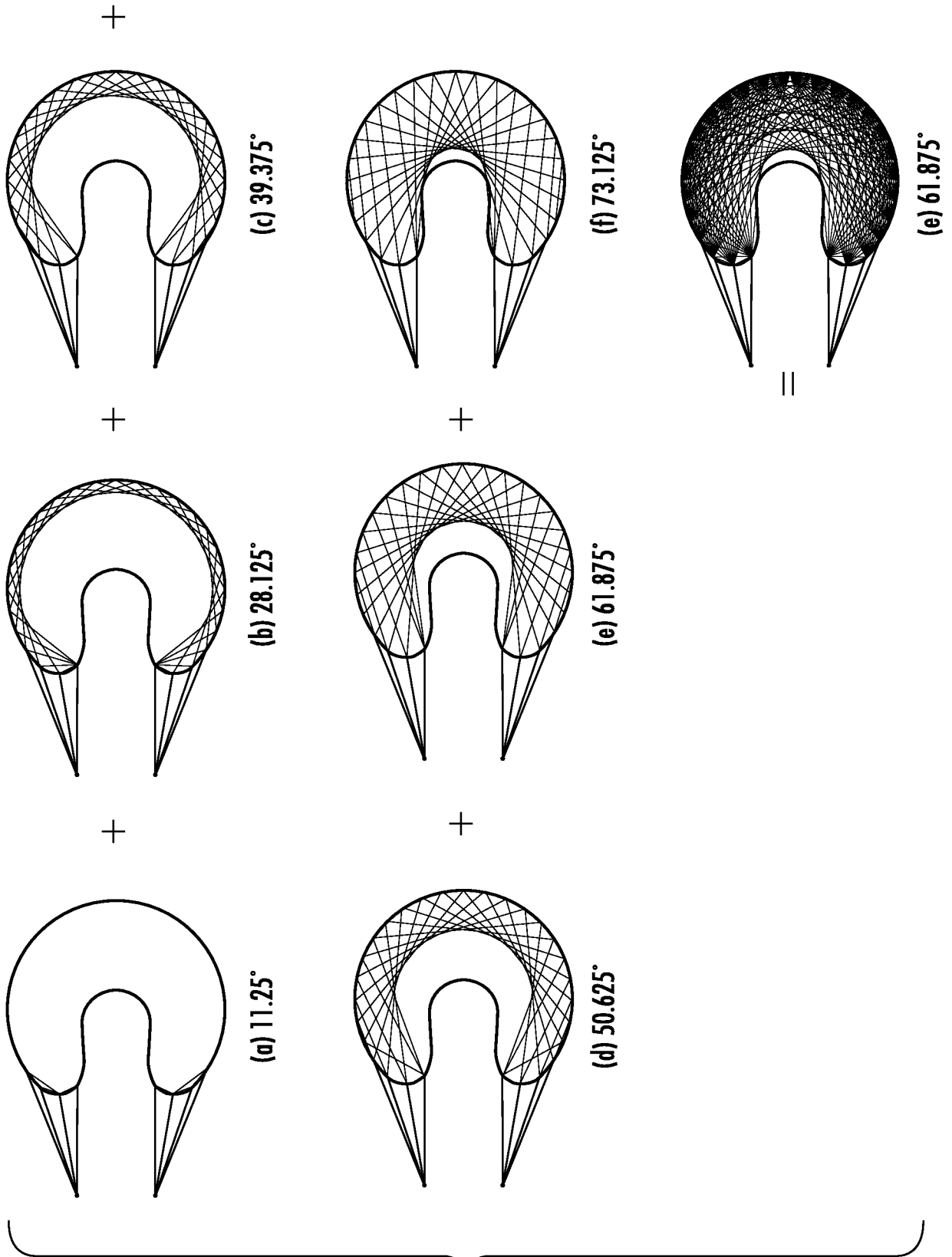

FIG. 8

10/21

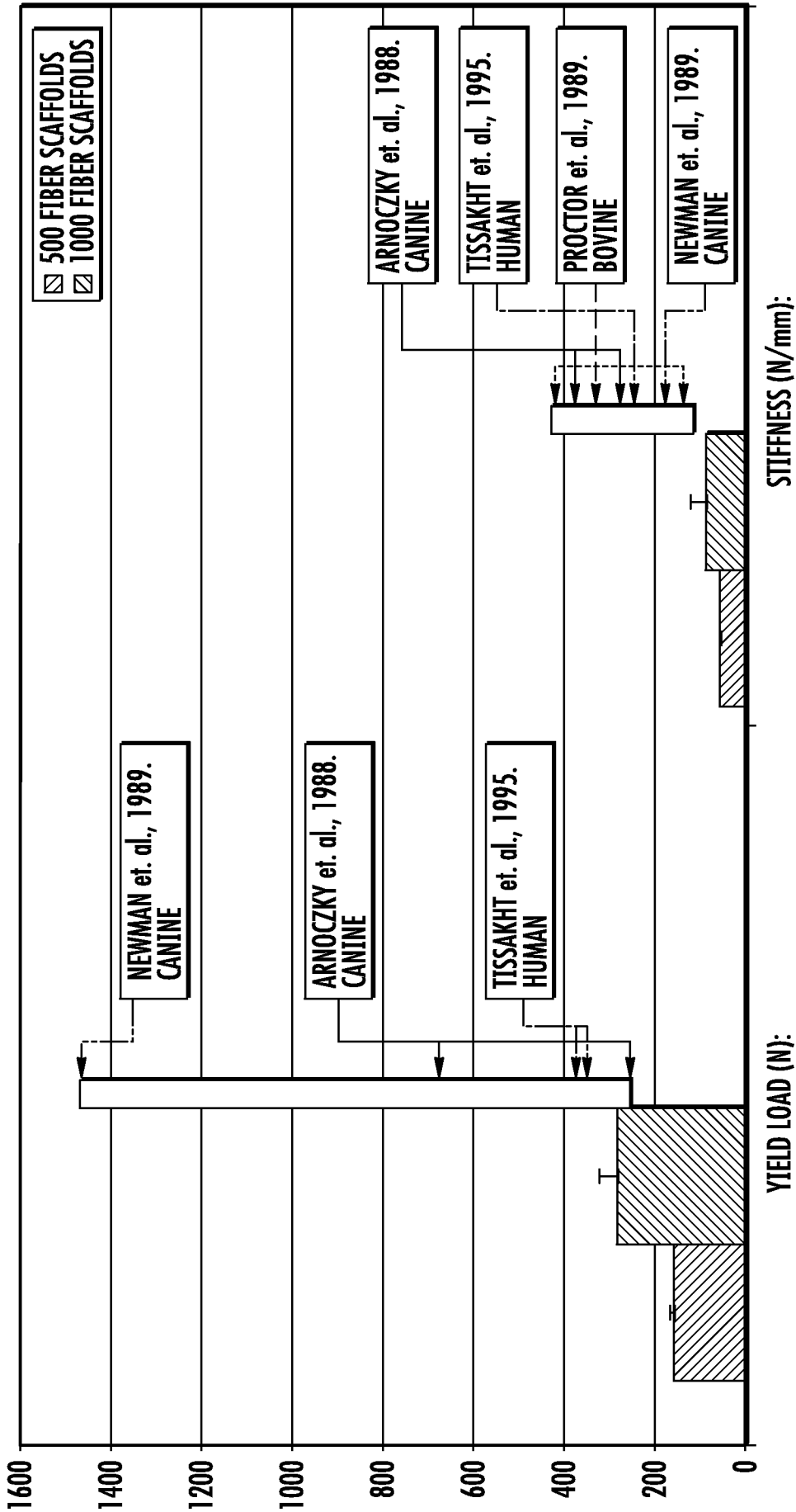
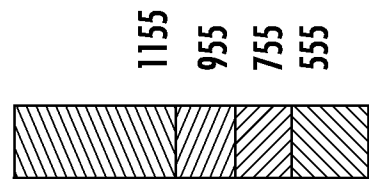
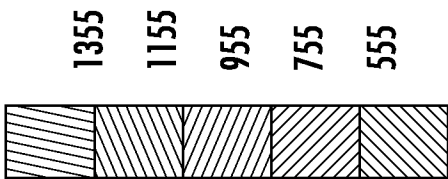
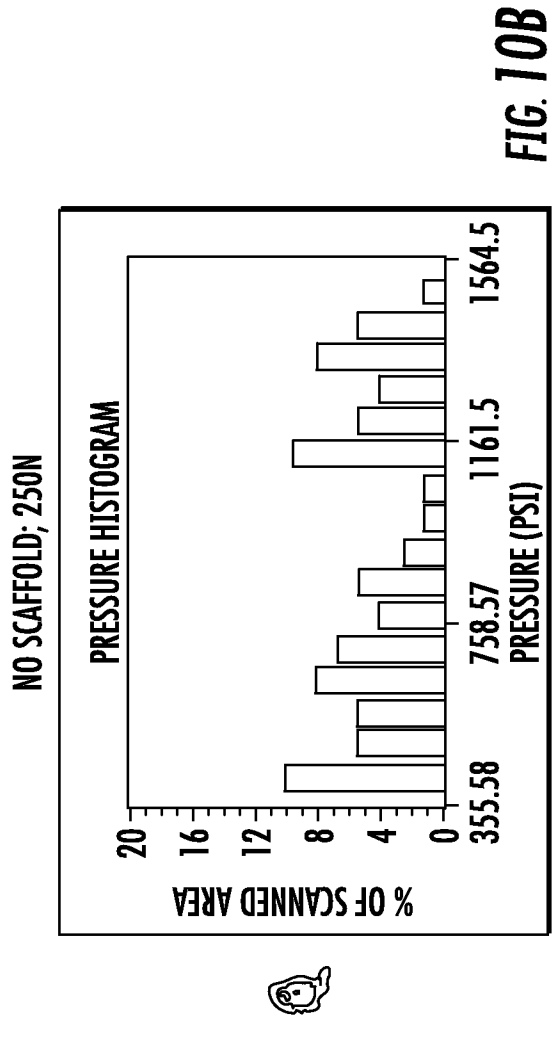
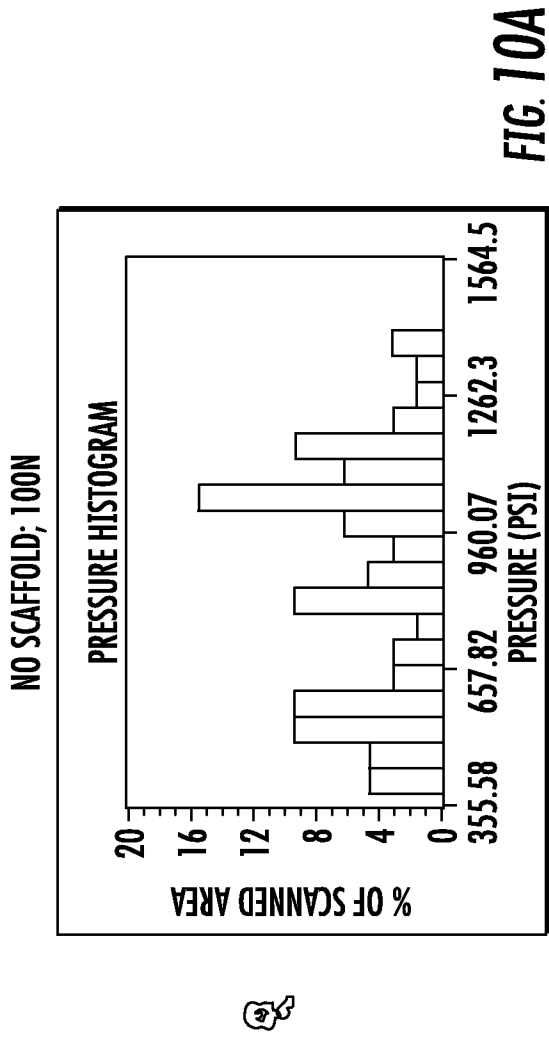

FIG. 9

11/21



12/21

100% COLLAGEN SCAFFOLD; 100N
PRESSURE HISTOGRAM
FIG. 11A

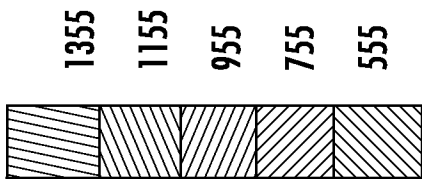
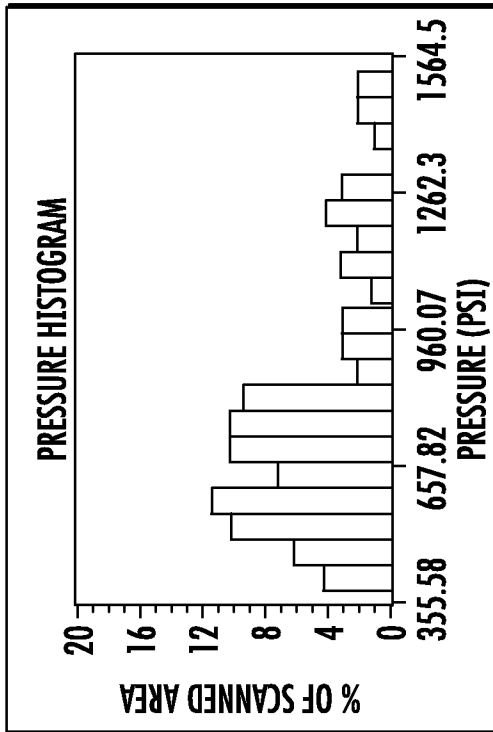

100% COLLAGEN SCAFFOLD; 250N
PRESSURE HISTOGRAM
FIG. 11B

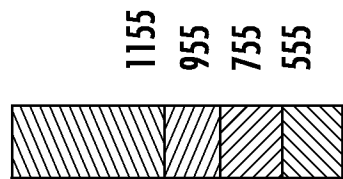
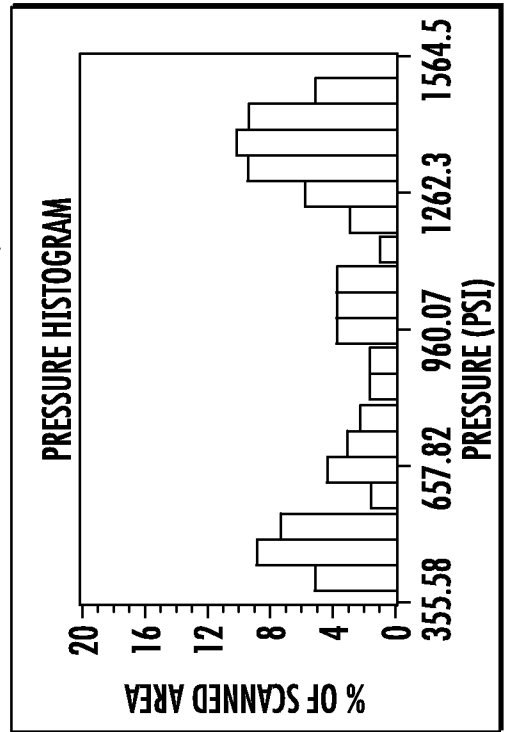

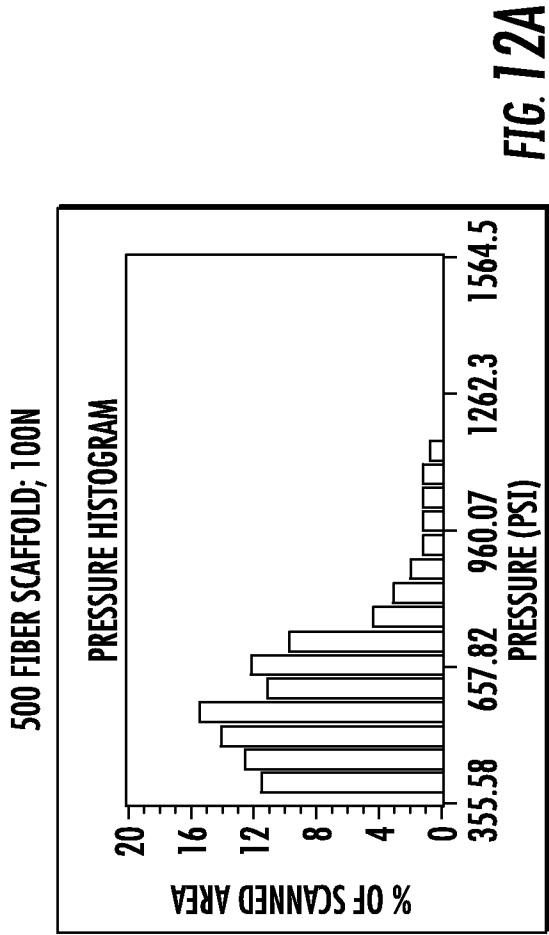

FIG. 12A

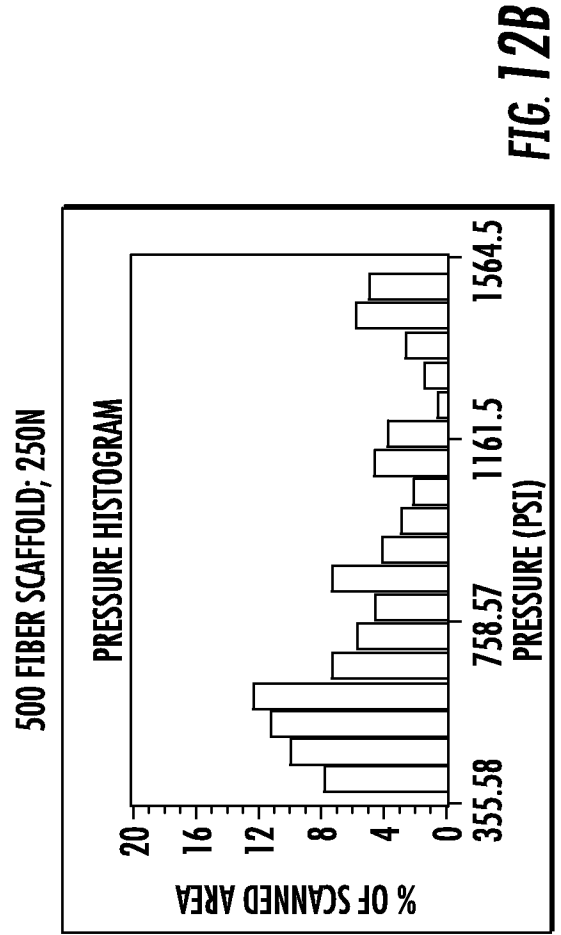
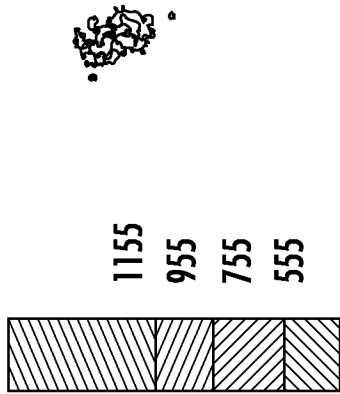
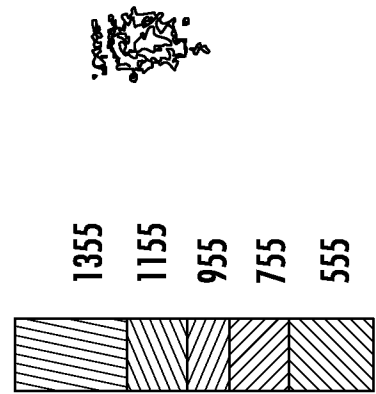

FIG. 12B



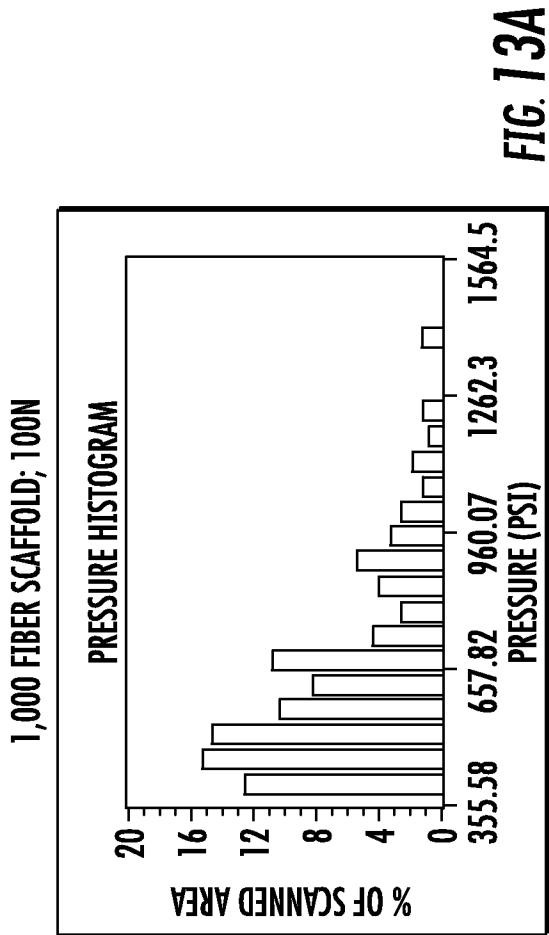

FIG. 13A

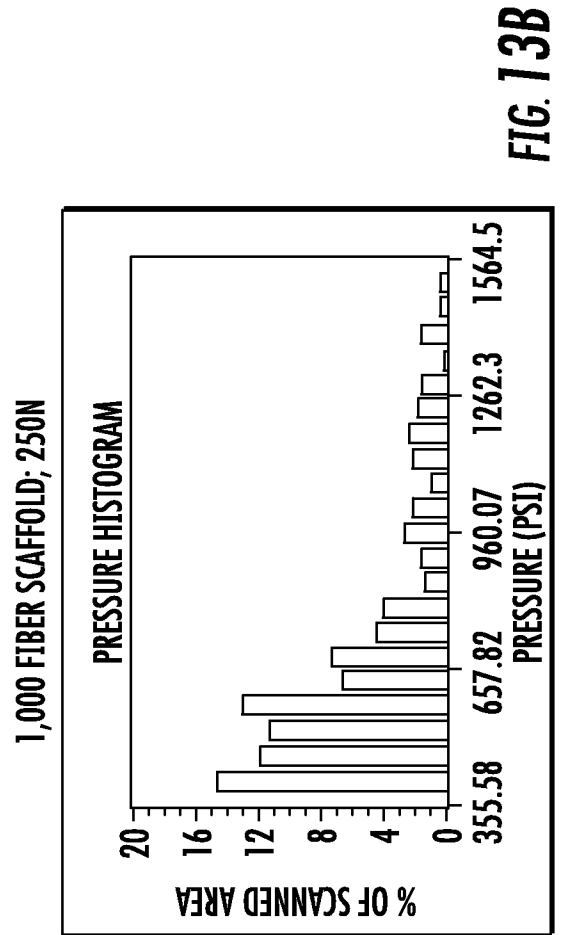
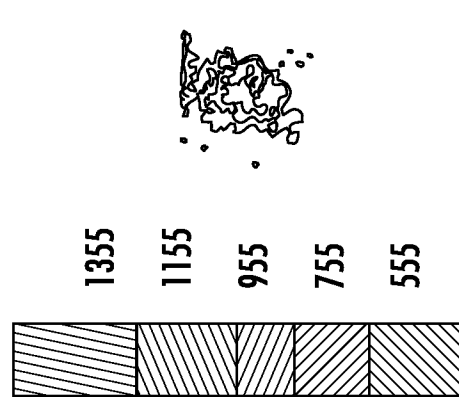
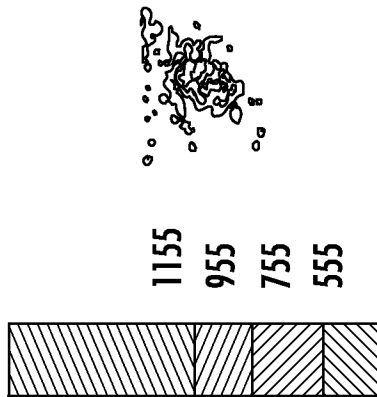

FIG. 13B



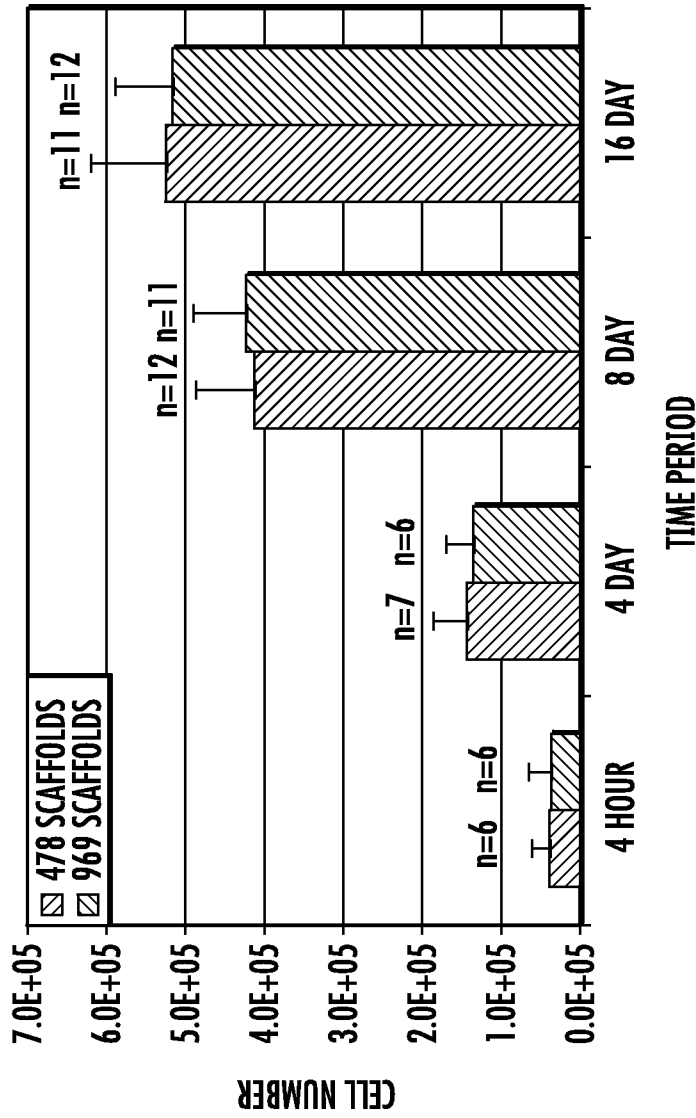

FIG. 14B

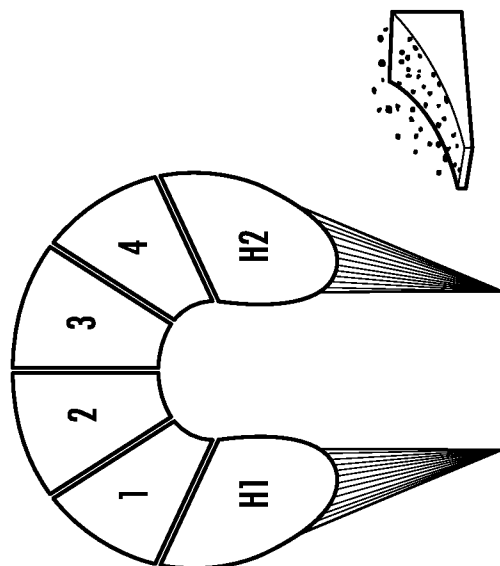

FIG. 14A

16/21

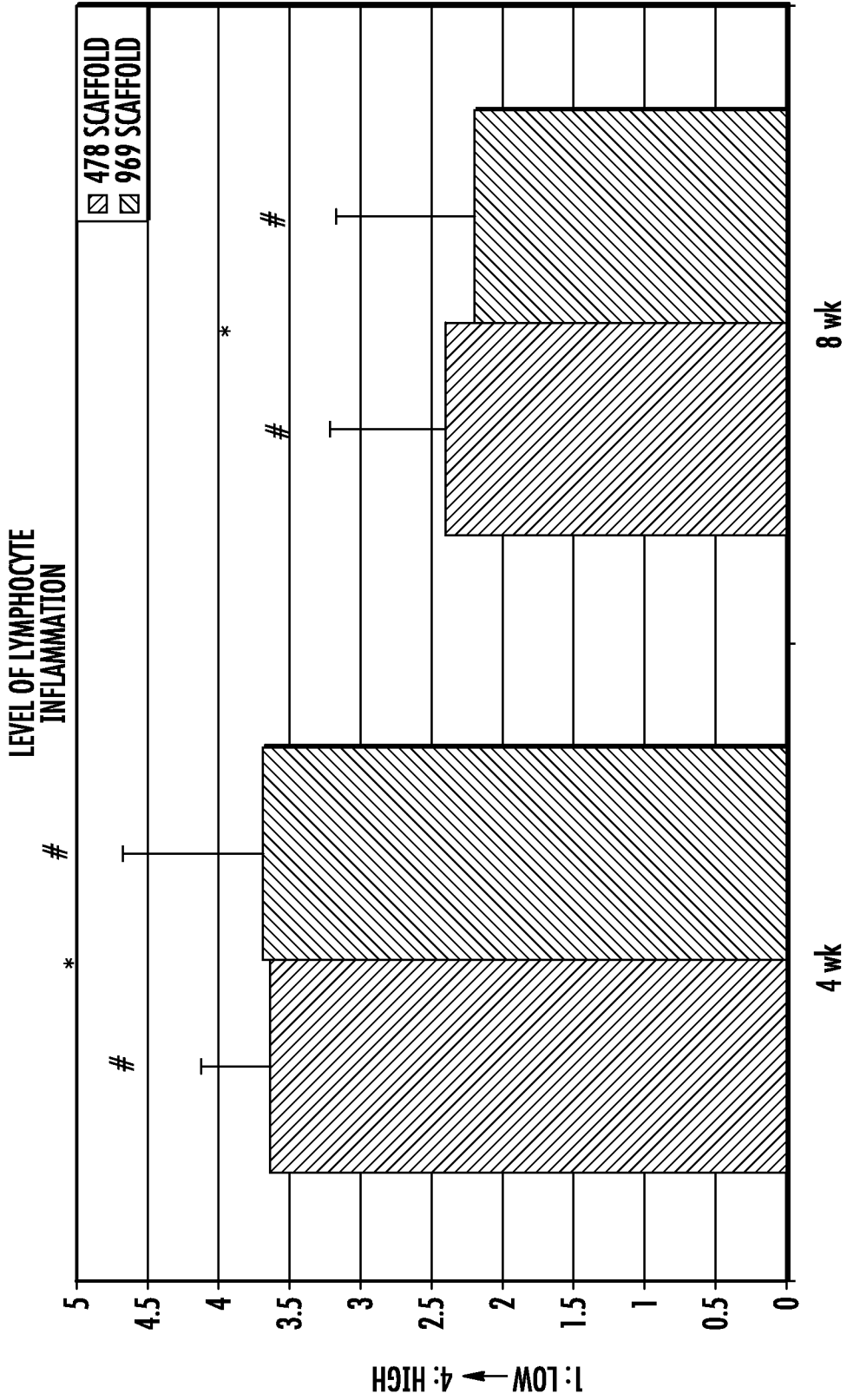

FIG. 15A

17/21

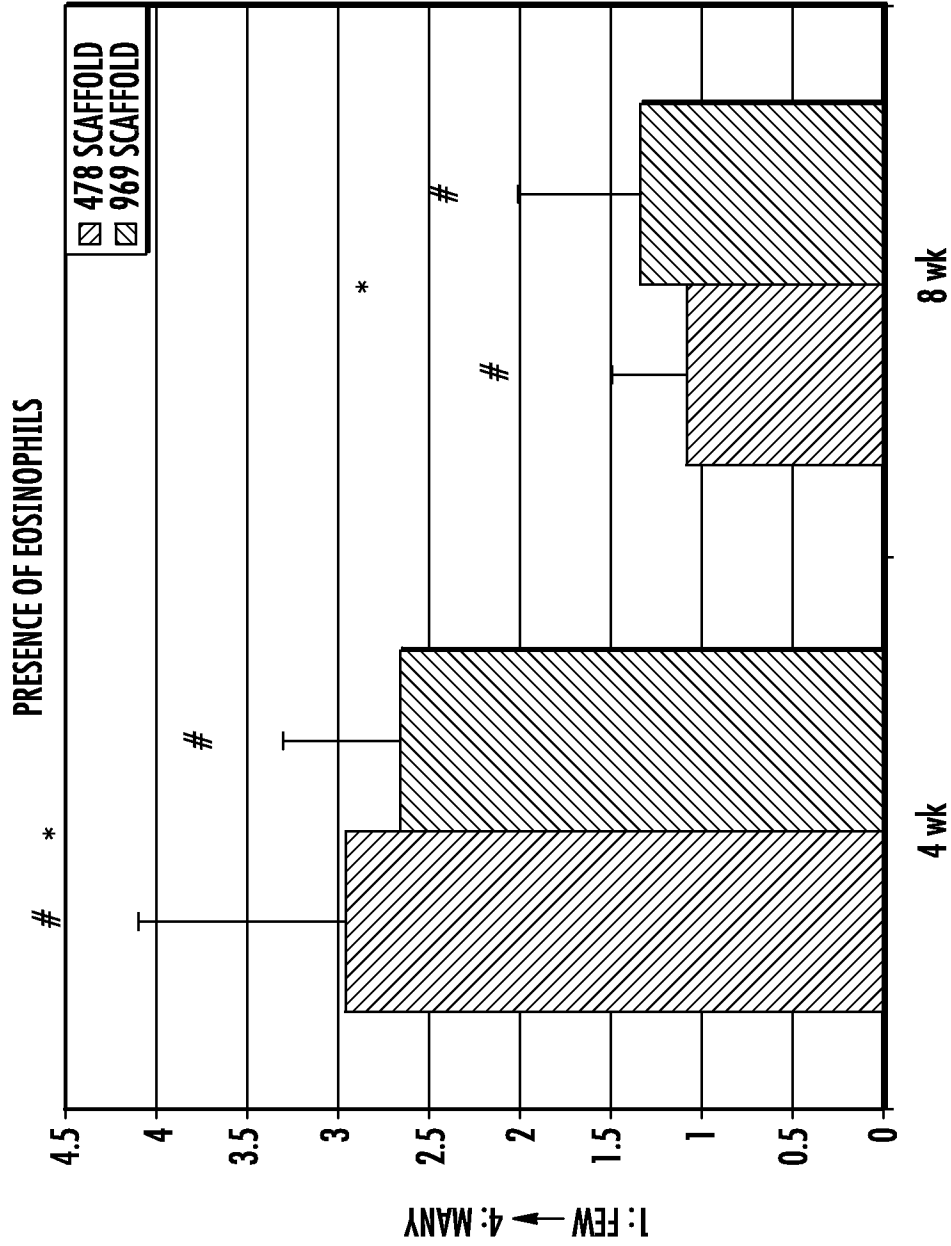

FIG. 15B

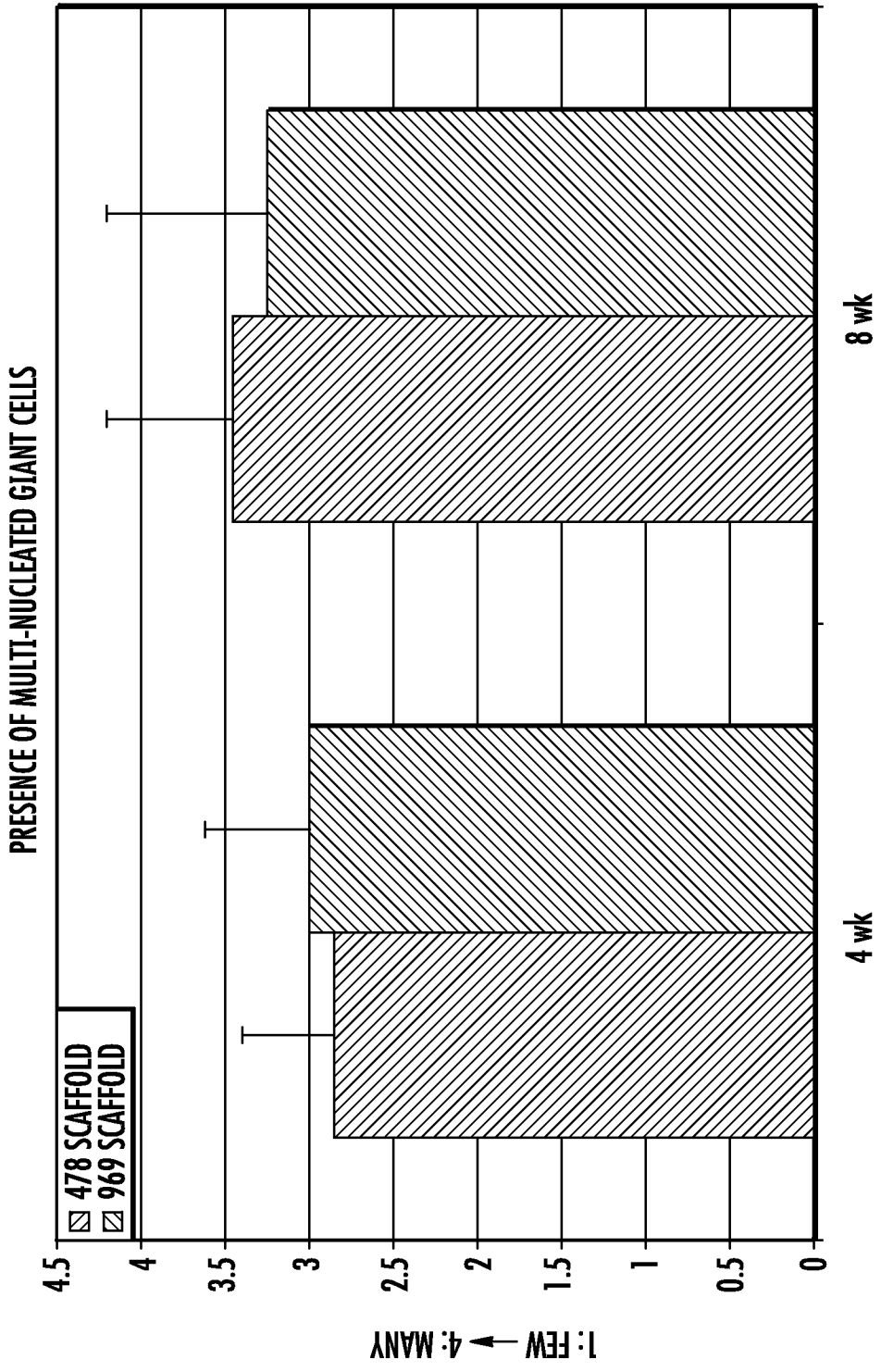

FIG. 15C

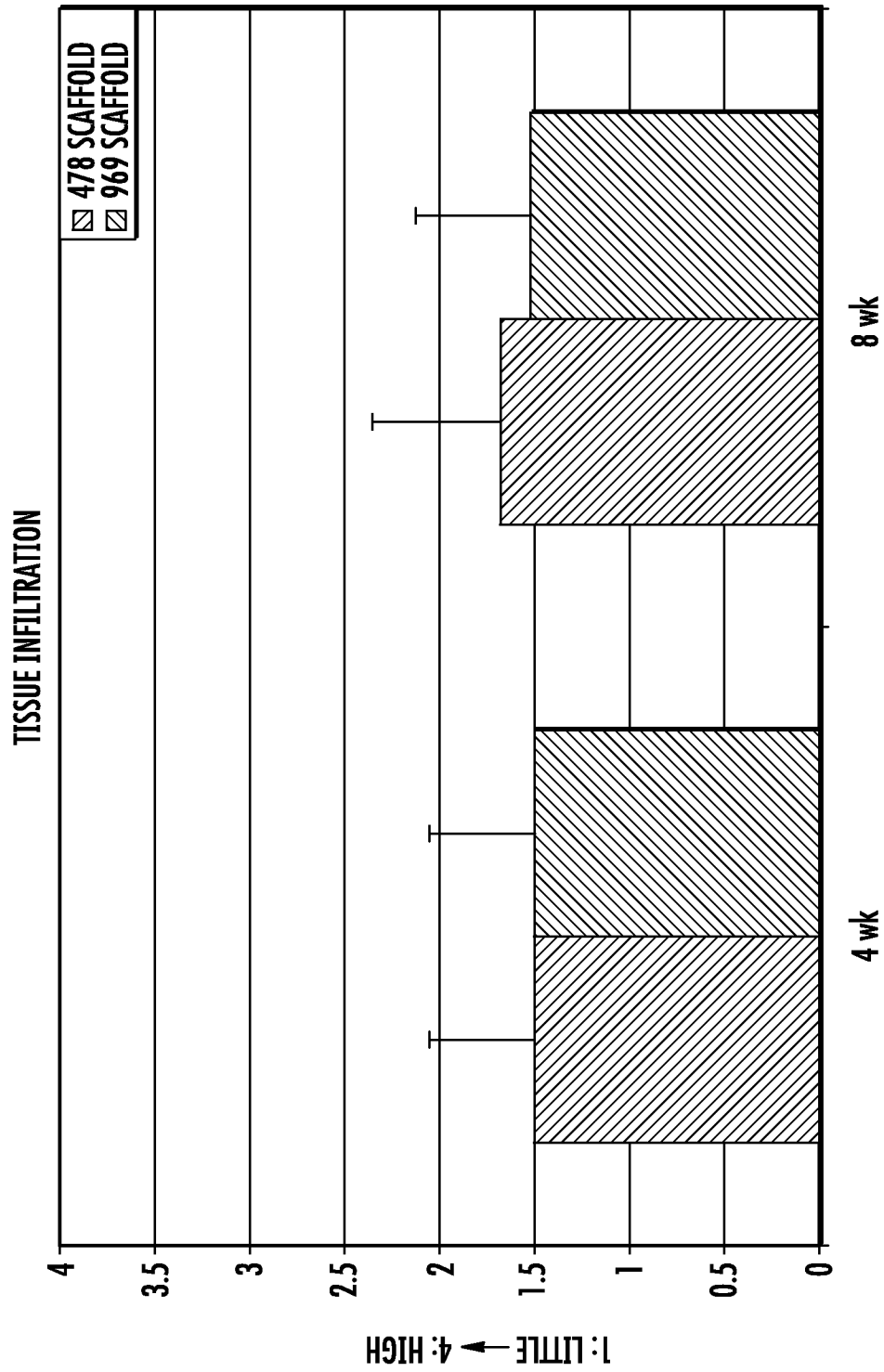

FIG. 15D

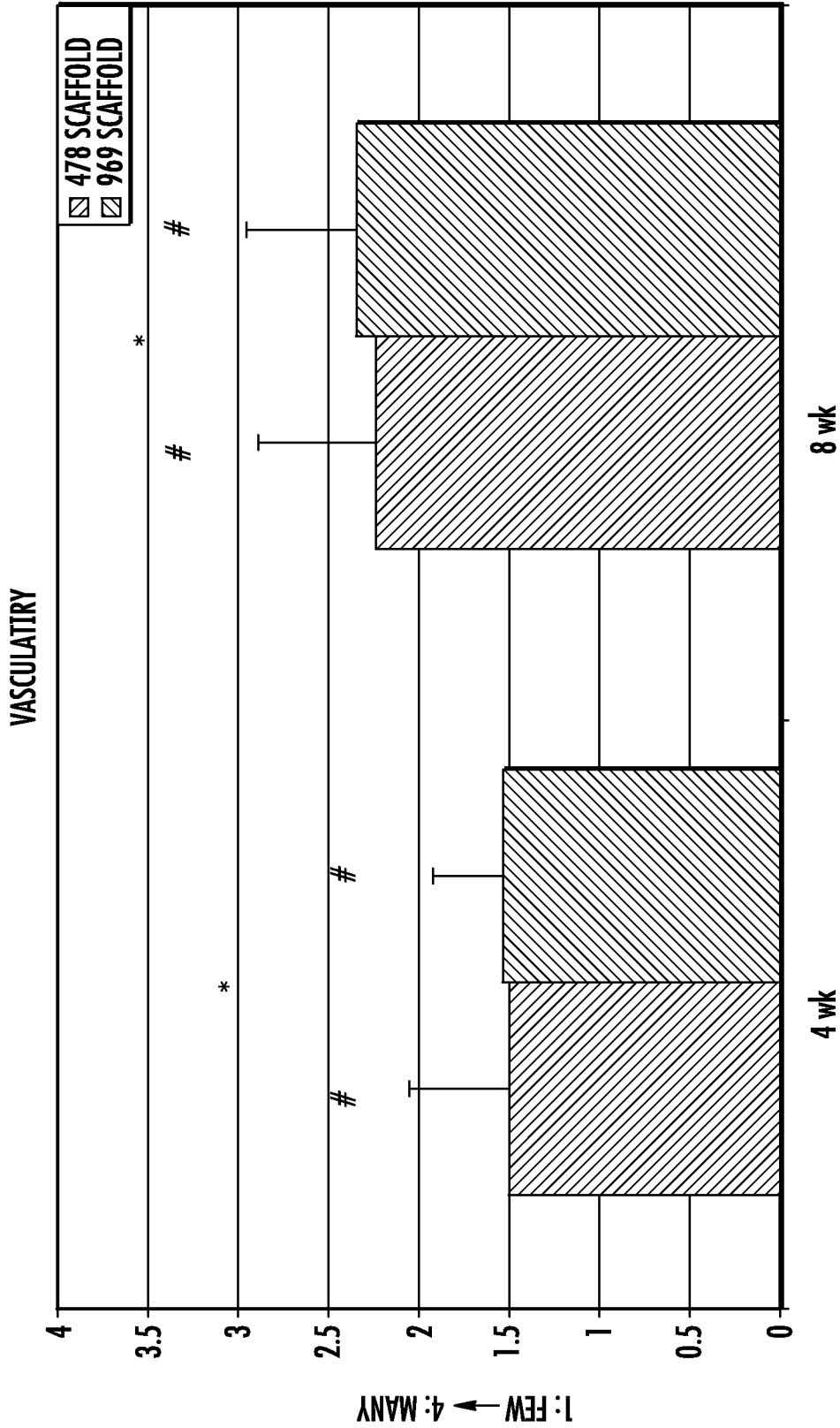

FIG. 15E

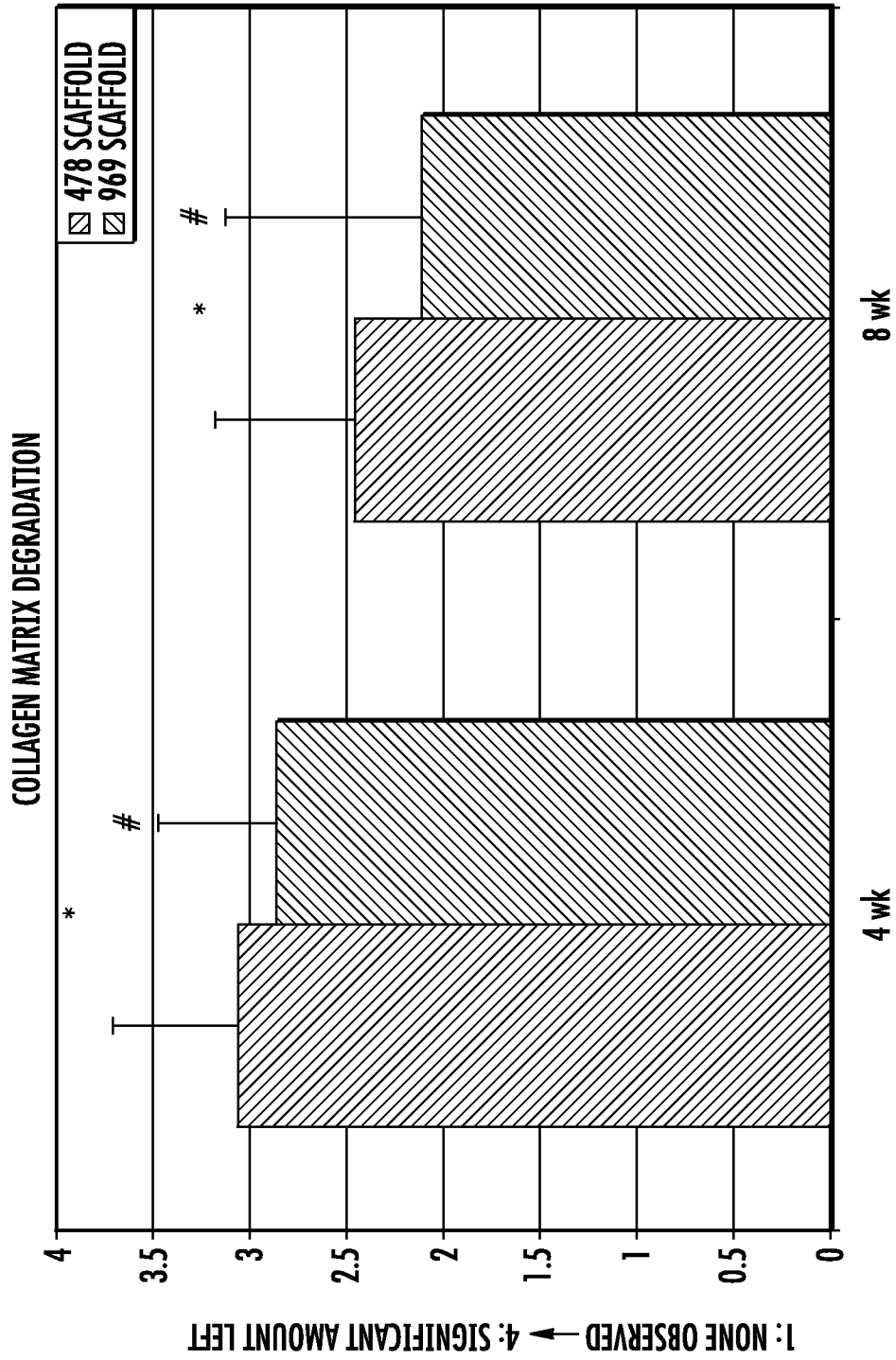

FIG. 15F

INTERNATIONAL SEARCH REPORT

International application No.

PCT/US2009/045985

A. CLASSIFICATION OF SUBJECT MATTER IPC(8) - A61F 2/08 (2009.01) USPC - 623/14.12 According to International Patent Classification (IPC) or to both national classification and IPC		
B. FIELDS SEARCHED Minimum documentation searched (classification system followed by classification symbols) IPC(8) - A61F 2/00, 2/02, 2/08 (2009.01) USPC - 424/423; 623/13.18, 14.12, 23.76 Documentation searched other than minimum documentation to the extent that such documents are included in the fields searched Electronic data base consulted during the international search (name of data base and, where practicable, search terms used) PatBase, Google Search		
C. DOCUMENTS CONSIDERED TO BE RELEVANT		
Category*	Citation of document, with indication, where appropriate, of the relevant passages	Relevant to claim No.
X	US 5,158,574 A (STONE) 27 October 1992 (27.10.1992) entire document	1-11, 22-28, 30-37
A	US 2004/0133275 A1 (MANSMANN) 08 July 2004 (08.07.2004) entire document	1-11, 22-28, 30-37
A	US 2005/0177249 A1 (KLADAKIS et al) 11 August 2005 (11.08.2005) entire document	1-11, 22-28, 30-37
<input type="checkbox"/> Further documents are listed in the continuation of Box C. <input type="checkbox"/>		
* Special categories of cited documents: "A" document defining the general state of the art which is not considered to be of particular relevance "E" earlier application or patent but published on or after the international filing date "L" document which may throw doubts on priority claim(s) or which is cited to establish the publication date of another citation or other special reason (as specified) "O" document referring to an oral disclosure, use, exhibition or other means "P" document published prior to the international filing date but later than the priority date claimed "T" later document published after the international filing date or priority date and not in conflict with the application but cited to understand the principle or theory underlying the invention "X" document of particular relevance; the claimed invention cannot be considered novel or cannot be considered to involve an inventive step when the document is taken alone "Y" document of particular relevance; the claimed invention cannot be considered to involve an inventive step when the document is combined with one or more other such documents, such combination being obvious to a person skilled in the art "&" document member of the same patent family		
Date of the actual completion of the international search 17 July 2009		Date of mailing of the international search report 27 JUL 2009
Name and mailing address of the ISA/US Mail Stop PCT, Attn: ISA/US, Commissioner for Patents P.O. Box 1450, Alexandria, Virginia 22313-1450 Facsimile No. 571-273-3201		Authorized officer: Blaine R. Copenheaver PCT Helpdesk: 571-272-4300 PCT OSP: 571-272-7774

INTERNATIONAL SEARCH REPORT

International application No.

PCT/US2009/045985

Box No. II Observations where certain claims were found unsearchable (Continuation of item 2 of first sheet)

This international search report has not been established in respect of certain claims under Article 17(2)(a) for the following reasons:

- 1. Claims Nos.:
because they relate to subject matter not required to be searched by this Authority, namely:

- 2. Claims Nos.:
because they relate to parts of the international application that do not comply with the prescribed requirements to such an extent that no meaningful international search can be carried out, specifically:

- 3. Claims Nos.: 12-21, 29
because they are dependent claims and are not drafted in accordance with the second and third sentences of Rule 6.4(a).

Box No. III Observations where unity of invention is lacking (Continuation of item 3 of first sheet)

This International Searching Authority found multiple inventions in this international application, as follows:

- 1. As all required additional search fees were timely paid by the applicant, this international search report covers all searchable claims.
- 2. As all searchable claims could be searched without effort justifying additional fees, this Authority did not invite payment of additional fees.
- 3. As only some of the required additional search fees were timely paid by the applicant, this international search report covers only those claims for which fees were paid, specifically claims Nos.:

- 4. No required additional search fees were timely paid by the applicant. Consequently, this international search report is restricted to the invention first mentioned in the claims; it is covered by claims Nos.:

- Remark on Protest**
- The additional search fees were accompanied by the applicant's protest and, where applicable, the payment of a protest fee.
 - The additional search fees were accompanied by the applicant's protest but the applicable protest fee was not paid within the time limit specified in the invitation.
 - No protest accompanied the payment of additional search fees.