

(19) World Intellectual Property Organization
International Bureau



(43) International Publication Date
27 December 2007 (27.12.2007)

PCT

(10) International Publication Number
WO 2007/147225 A2

- (51) International Patent Classification:
C02F 11/04 (2006.01)
- (21) International Application Number:
PCT/BR2007/000163
- (22) International Filing Date: 22 June 2007 (22.06.2007)
- (25) Filing Language: English
- (26) Publication Language: English
- (30) Priority Data:
BRMU 8601519-2 23 June 2006 (23.06.2006) BR
- (71) Applicant (for all designated States except US): SANSUY S/A INDUSTRIA DE PLÁSTICOS [BR/BR]; Rua dos Plásticos, 761, 42800-000 Camaçari - BA (BR).
- (72) Inventor: HONDA, Takeshi (deceased).
- (74) Agent: EDMUNDO BRUNNER ASSESSORIA EM PI LTDA; Att.:Marcelo Brunner, Av. Brigadeiro Luis Antonio, 4329, 01401-002 São Paulo - SP (BR).
- (81) Designated States (unless otherwise indicated, for every kind of national protection available): AE, AG, AL, AM,

AT, AU, AZ, BA, BB, BG, BH, BR, BW, BY, BZ, CA, CH, CN, CO, CR, CU, CZ, DE, DK, DM, DO, DZ, EC, EE, EG, ES, FI, GB, GD, GE, GH, GM, GT, HN, HR, HU, ID, IL, IN, IS, JP, KE, KG, KM, KN, KP, KR, KZ, LA, LC, LK, LR, LS, LT, LU, LY, MA, MD, MG, MK, MN, MW, MX, MY, MZ, NA, NG, NI, NO, NZ, OM, PG, PH, PL, PT, RO, RS, RU, SC, SD, SE, SG, SK, SL, SM, SV, SY, TJ, TM, TN, TR, TT, TZ, UA, UG, US, UZ, VC, VN, ZA, ZM, ZW.

(84) Designated States (unless otherwise indicated, for every kind of regional protection available): ARIPO (BW, GH, GM, KE, LS, MW, MZ, NA, SD, SL, SZ, TZ, UG, ZM, ZW), Eurasian (AM, AZ, BY, KG, KZ, MD, RU, TJ, TM), European (AT, BE, BG, CH, CY, CZ, DE, DK, EE, ES, FI, FR, GB, GR, HU, IE, IS, IT, LT, LU, LV, MC, MT, NL, PL, PT, RO, SE, SI, SK, TR), OAPI (BF, BJ, CF, CG, CI, CM, GA, GN, GQ, GW, ML, MR, NE, SN, TD, TG).

Published:
— without international search report and to be republished upon receipt of that report

For two-letter codes and other abbreviations, refer to the "Guidance Notes on Codes and Abbreviations" appearing at the beginning of each regular issue of the PCT Gazette.

(54) Title: IMPROVEMENT OF ANAEROBIC BIODIGESTER UTILIZED FOR BIOGAS CAPTATION

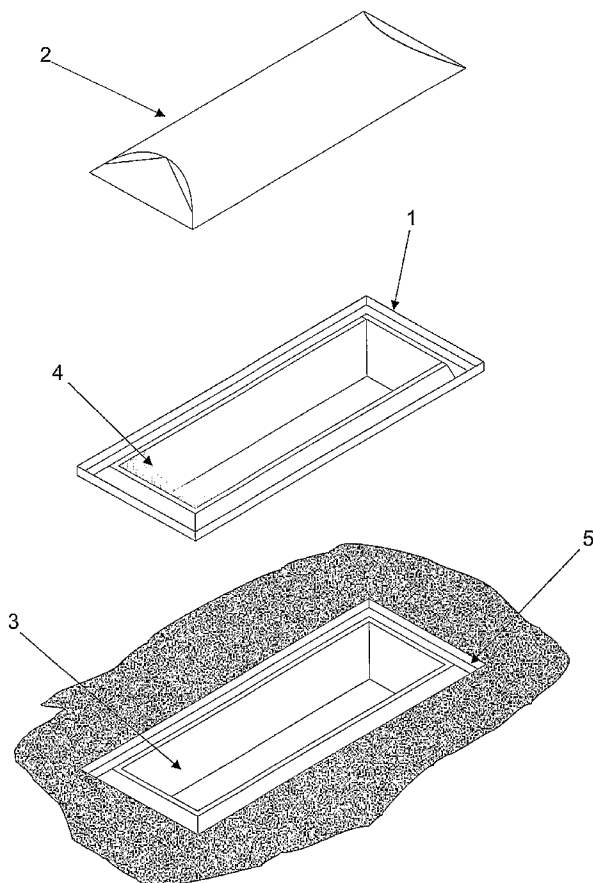

(57) Abstract: Improvement of anaerobic biodigester utilized for biogas captation, totally built with plastic blankets that make up: base (1) in the shape of a reservoir or lake for organic matter collection and cover like a dome (2), which works as an actual chamber to gather the generated gas, so that it can be collected and utilized as energy for different appliances; the referred base blanket (1) is outspread covering totally a big cove (3), molding itself against the side walls and bottom, so that it can form a reservoir or lake (4) for collection of organic matter to be processed, and this blanket also outspreads beyond the peripheral limits of the mentioned cove, where it is confined by an anchoring groove (5) with a preferably trapezoidal profile, where both blankets have overlapping stretches (9) and linked (10) and there are also means included for corrective or preventive maintenance, which are represented by at least one intermediate blanket (12).

WO 2007/147225 A2

IMPROVEMENT OF ANAEROBIC BIODIGESTER UTILIZED FOR BIOGAS CAPTATION.

Invention Field.

More specifically, this Invention refers to technical and functional
5 improvement on a particular type of biodigester totally built with plastic
blankets, preferably any color of flexible PVC acquired through calendaring
process. In general, these blankets make up the biodigester's two main
parts, the first one is a reservoir or lake for organic matter collection, whilst
the second part, also known as dome, works as an actual chamber to
10 gather the generated gas, so that it can be collected and utilized as energy
for different appliances.

The anaerobic biodigester is an equipment used to produce biogas, a
mixture of gases, mostly methane, produced by bacteria which digest
organic matter under anaerobic conditions, i.e., absence of oxygen.
15 Therefore, biodigester is a kind of chemical reactor where the reactions
have a biological origin. There are many sources of organic matter used to
feed biodigesters, always with an ecologic purpose thus, the processed
matter can derive from vegetal production residues, such as remains of
several cultures, residues from different animals, mostly manure and urine,
20 including those produced by human activity, such as: excrements, urine and
domestic waste. Thus, different organic residues, whether they are
industrial, commercial, domestic or other, may be used in a biodigester, not
only with to produce methane gas, but also so that such residues can be
treated and discharged according to an ecologically acceptable quality.

25 Biogas is a source of energy to be employed in different sectors, from
domestic to industrial, obviously as a fuel for heating, at the same time as
avoiding that this kind of gas is released into the atmosphere, causing great
damage to the environment. It can be used as a replacement fuel to natural
gas or Liquefied Petroleum Gas (LPG), both extracted from mineral reserves.
30 Biogas can be used for cooking in rural residences close to the production
sites (saving other sources of energy, particularly, firewood or LPG). It can
also be used on rural production as, for instance, lodge heating for cold
sensitive animals, or heating for vegetal production greenhouses. It can also

be used for electric power generation through electric generators attached to explosion engines adapted to gas consumption.

One cubic meter (1 m³) of biogas is energetically equal to:

1.5 m³ cooking gas;

5 0.52 to 0.6 liter of gasoline;

15 0.9 liter of alcohol;

1.43 KWh of electricity;

2.7 Kg of firewood (burnt wood).

10 The effluent (fluid that leaves the biodigester after the time needed for organic matter digestion by bacteria) has fertilizing properties. Besides water, the effluent fluid, known as biofertilizer, presents chemical elements such as nitrogen, phosphor and potassium in amounts and chemical forms that can be used directly to fertilize vegetal species by fertirrigation. The biofertilizer is 90 - 95 % water (i. e., 5 - 10% dry fraction of the fluid). In
15 this dry base, the amount of nitrogen - depending on its source material - is between 1.5 - 4% nitrogen (N), 1 - 5% phosphor (P₂O₅) and 0.5 - 3% potassium (K₂O).

The same biodigester that treats waste from cowshed or pigpen or bovine confinement can be connected to domestic sewage from residences.
20 Although they are used primarily as sources of energy and organic fertilizers for rural producers, biodigesters can also be approached as a system of human waste treatment in small urban communities.

Oxygen (O₂) from the air is lethal for anaerobic bacteria. If there is oxygen in the environment, bacteria will paralyze their metabolism and stop
25 developing. The bacteria that use oxygen produce carbon dioxide (CO₂) as final product of their breathing. On the other hand, anaerobic bacteria produce methane. Methane is a chemical energy rich gas and, therefore, can be used as fuel. CO₂ is already totally oxidized and cannot be used as fuel. If the biodigester is not hermetically sealed against air intake, there is
30 no biogas production, because the anaerobic bacteria die and the aerobic ones survive. The biogas produced will then be CO₂ rich rather than methane rich. Thus, the biodigester must ensure anaerobiosis of the bacteria environment.

The main nutrients for microorganisms are carbon, nitrogen and mineral salts. Animal waste (including human) is nitrogen rich sources. Vegetal culture remains are carbon rich sources. The mineral salts present on animal waste and vegetal residues are enough for the bacteria mineral nutrition. However, if there isn't an appropriate balance between carbon compounds (that supply energy) and nitrogen compounds (that supply nitrogen) there won't be an efficient production of biogas.

Just to illustrate, a biodigester with bovine manure stays an average of thirty to forty days sealed, without oxygen, where the only activity is gas removal. After it is opened, the remaining biomass is removed, which can be used as a natural fertilizer, and new material is added, repeating the process.

Estate of Art

Currently, different plants for the production of biogas and, therefore, for the treatment of diverse residues are known, all of which are simply referred to as "biodigesters". However, they are also classified as small, medium and big in size. This is clearly to meet different project situations, since, small size plants are useful, for example, for small production of animal waste.

Thus, this technology is already know and taught by different documents, such as those described in the following documents: BR MU 8601519-2 from 06/23/2006 compact device for treatment of animal waste and residuary water; BR MU 8502055-9 from 09/27/2005 - constructive disposition on a system for treatment of residuary water; BR MU 8403433-5 from 10/25/2004 - modular biodigester for production of biofertilizer biogas and biofood; BR PI 0403524-0 from 06/03/2004 - biodigester of interconnected containers; BR MU 8400518-1 from 03/30/2004 constructive disposition on biodigester; BR MU 8400800-8 from 02/12/2004 - fiberglass based biodigester for production of biofertilizer and biogas; BR PI 0202741-0 from 17/07/2002 - ascending flux biodigester with mud blanket and hydraulic seal for waste treatment; BR PI 8604114-2 from 08/20/1986 - biodigester comprized of wind promoted agitation reactor and hydrodynamic lung to supply constant nominal pressure; BR MU 6301380-0 from

09/21/1983 - vertical biodigester; BR MU 6200791-2 from 06/01/1982 - micro distillery-biodigester integrated system; and US 4040963 from 08/09/1977.

5 There is no doubt that plants acquired according to the instructions above are appropriate means for biogas captation as well as adequate treatment of residual organic matter, however, some biodigesters, specially that described in document BR MU 8601519-2 from 06/23/2006 compact device for treatment of animal waste and residuary water, is the type totally made of plastic blankets, preferably flexible PVC in any color, acquired by
10 calendering process. In general, these blankets make up the biodigester's two main parts, the first one is a reservoir or lake for collection of organic matter to be treated, whilst the second part is a cover, also known as dome, which works as an actual chamber to gather the generated gas, so that it can be collected and utilized as energy for different appliances.

15 This improvement is particularly related to biodigesters made of plastic blankets, where the life cycle of the set is associated to eventual corrective and preventive maintenance. On the other hand, through the years, it was noticed that the most vulnerable part of the set is exactly the cover or dome, since that is the exposed one, hence, it is subject to
20 unexpected events, mainly those caused by rough weather and, obviously, also suffers the effects of temperature variation and sun exposure. These and other factors collaborate to attack the blanket's properties, which, in turn, despite being a highly resistant material, may be subject to damages that compromise the working effectiveness of the set. Such damages may
25 be small, i.e., holes, tears and the like, occurring at isolated spots on the cover, however, there may happen greater damages which demand total replacement of the cover.

30 On conventional biodigesters, mainly the one described on document BR MU 8601519-2, the seal between cover and blanket that forms the reservoir or side is made by chemical sealing, i.e., both parts borders are hermetically bonded to each other. Although efficient, this construction has been proved as a drawback when it is time for eventual maintenances, particularly when it comes to changing the cover blanket (dome), since the

biggest trouble is to separate the two parts without damaging the one that will not be replaced (base blanket of the lake). Even though it is possible to perform different repairs, the work has become slow and expensive, demanding a more practical and effective practice that could be prepared in advance for eventual corrective or preventive maintenance.

Purposes of the Invention.

It is an improvement exactly at the binding point between the cover blanket and the blanket that forms the lake. Innovative means of "wait" were created at this binding point, which is actually a constructive preventive way designed to allow separation from the cover blanket by cutting it on a peripheral region considerably close to the base that forms the lake. It is possible to make this cut without damaging the aforementioned lake forming blanket. This cut or separation may be partial or total and, after that, the substitute cover blanket is chemically sealed again, although, in this case, a direct link with the blanket that forms the lake is not used, but rather an internal brim in the shape of a complement blanket of the same material that was previously sealed between both blankets. This constructive shape, besides being totally new, speeds up a lot eventual preventive and corrective maintenances.

The inventions also aims at transparent windows at several strategic points at the cover blanket so that it can be possible to view the whole inside part of the lake for defining eventual maintenances, specially cleaning floatsam and jetsam.

Drawings description.

For a better understanding of this Invention, there follows a detailed description of it, referring to the attached drawings, intentionally elaborated out of scale and with exaggerated dimensions, in order to make clear the different layers that make the whole; where:

FIGURE 1 represents an exploded perspective, schematically highlighting the main parts that form the biodigester's body and the place where it is set up;

FIGURE 2 shows another schematic perspective, now, of the whole assembled set;

FIGURE 3 illustrates a cross section perspective showing the different layers that make the set;

FIGURE 4 is a panoramic view schematically showing the set installed on the floor;

5 **FIGURE 5** shows a superior view;

FIGURE 6 reproduces a cross section view of the assembled set;

FIGURES 7 to 12 are schematic enlarged views showing the "A" detail pointed out on figure 6 in different constructive conditions, and

10 **FIGURE 13** shows a perspective highlighting a peculiarity of the improvement in question, which is the forecast of transparent windows at strategic points of the cover blanket.

Detailed description of the invention.

According to these illustrations and in its details, specially figures 1 to 6, this Invention, **IMPROVEMENT OF ANAEROBIC BIODIGESTER UTILIZED FOR BIOGAS CAPTATION**, is the type built totally with plastic blankets, preferably flexible PVC in any color or another equivalent material, acquired through calendering process or not. In general, these blankets, as described on document BR MU 8601519-2, make up the two main parts of the biodigester, where the first one is the base blanket (1) which forms a reservoir or lake for organic matter collection, whilst the second one is a cover blanket like a dome (2), that works as an actual chamber to gather the generated gas, so that it can be collected and utilized as energy for different appliances.

25 Traditionally, the referred base blanket (1) is outspread totally covering a big cove (3), molding itself against the bottom and side walls, so that it can form a reservoir or lake (4) for collection of organic matter to be processed, and this blanket also outspreads beyond the peripheral limits of the mentioned cove, where it is confined by a anchoring groove (5), better seen on figure 7, where it shows a preferably trapezoidal profile, defined by
30 a first inclined descending side (6), a bottom part (7) and a last inclined ascending side (8), where it ends or where the border of the base blanket that forms the lake is positioned (1), and, in the inside of the referred anchoring groove (5), preferably on its descending side (6), both blankets

present overlapping stretches (9), where they are hermetically linked by 10 preferably chemical bonds (10) and, after that, the anchoring groove (5), such as figure 8 illustrates, is filled with an appropriate material (11), such as earth, hail or a convenient ersatz, thus finishing the ways of anchoring the 5 biodigester's body, which, as mentioned, includes other numberless parts that are not illustrated and are intrinsic parts 15 of the system, mostly piping for the intake of material to be processed, piping for gas output, structural pieces, reinforcement pieces and others, however, such parts have already been thoroughly described on former patents and do not 10 comprise technical matter to be claimed in this improvement.

According to what figure 9 illustrates, this improvement is distinguished by the fact that, on the stretch (9) where both blankets overlap, there are means included for corrective or preventive maintenance, which are represented by at least one intermediate blanket (12), preferably 15 made of the same material, such as flexible PVC in any color acquired by calendering process, and this blanket also outspreads through the whole perimeter of the set, where the height of the mentioned intermediate blanket (12) is preferably something squarely proportional to the extension of the height of the descending wall (6), and the inferior border of the intermediate 20 blanket (12) is hermetically linked to the base blanket (1) by a preferably chemical bond (13) that precedes the first hermetic bond (10), so that it is preferable to keep an appropriate distance between them (d), forming an access so that, for any reason, such as illustrated by figure 10, the cover blanket (2) may be subject to a section (14), either partial or along its 25 whole perimeter, separating itself from the base blanket (1), for total replacement or repair, as well as the new cover blanket (2), as illustrated on figure 11, is directly hermetically bond to the complementary blanket (12) by means of another preferably chemical bond (16) like the other ones (10-11).

30 According to what figure 12 illustrates, more than one complimentary layer is eventually expected (12) between the base blanket (1) and the cover blanket (2), which allows for more than one section (14) and, hence, it is possible to replace the cover blanket more than once (2).

According to what figure 13 illustrates, the inventions also aims at transparent windows (17) at several strategic points at the cover blanket (2) so that it can be possible to view the whole inside part of the lake for defining eventual maintenances, specially cleaning floatsam and jetsam.

5 As it is understandable, after what was exposed and illustrated, this really is an isolated improvement liable to be applied to different biodigesters built with a base blanket (1) and a cover blanket (2). This improvement, as mentioned before, comprises "means of wait" that facilitates eventual maintenance, whether corrective or preventive, by
10 means of total or partial replacement of the cover blanket (2). These means or resources represented by the intermediate blanket (12) do not exist on prior patent requests, thereafter, the advantages given by this improvement are not found on the previous technique.

CLAIMS

1) IMPROVEMENT OF ANAEROBIC BIODIGESTER UTILIZED FOR BIOGAS CAPTATION,

totally built with plastic blankets, preferably any color of flexible PVC or other equivalent material, acquired through calendering process or not, which make up the set's two main parts, where the first one is a base blanket (1) that makes up a reservoir or lake for the collection of organic matter, whilst the second one is a cover blanket like a dome (2), which works as an actual chamber to gather the generated gas, so that this gas may be collected and employed as energy for different appliances; the referred base blanket (1) is outspread covering totally a big cove (3), molding itself against the bottom and side walls, so that it can form a reservoir or lake (4) for collection of organic matter to be processed, and this blanket also outspreads beyond the peripheral limits of the mentioned cove, where it is confined by a anchoring groove (5) with a preferably trapezoidal profile, defined by a first inclined descending side (6), a bottom part (7) and a last inclined ascending side (8), where it ends or where the border of the base blanket that forms the lake is positioned (1), and, in the inside of the referred anchoring groove (5), preferably on its descending side (6), both blankets present overlapping stretches (9), where they are hermetically linked by preferably chemical bonds (10) and, after that, the anchoring groove (5) is filled with an appropriate material (11), such as earth, hail or a convenient ersatz, thus finishing the ways of anchoring the biodigester's body which, as mentioned, includes other numberless parts that are not intrinsic parts of the system, mostly piping for the intake of material to be processed, piping for gas output, structural pieces, reinforcement pieces and others; **characterized** by the fact that, on the stretch (9) where both blankets overlap, there are means included for corrective or preventive maintenance, which are represented by at least one intermediate blanket (12), preferably made of the same material, such as flexible PVC in any color acquired by calendering process, and this blanket also outspreads through the whole perimeter of the set, where the height of the mentioned intermediate blanket (12) is preferably something squarely proportional to the extension of the height of the descending wall (6), and

the inferior border of the intermediate blanket (12) is hermetically linked to the base blanket (1) by a preferably chemical bond (13) that precedes the first hermetic bond (10), so that it is preferable to keep an appropriate distance between them (d), forming an access so that, for any reason, the cover blanket (2) may be subject to a section (14), either partial or along its whole perimeter, separating itself from the base blanket (1), for total replacement or repair, as well as the new cover blanket (2) is directly hermetically bond to the complementary blanket (12) by means of another preferably chemical bond (16) like the other ones (10-11).

2) **IMPROVEMENT OF ANAEROBIC BIODIGESTER UTILIZED FOR BIOGAS CAPTATION**, according to claim 1, distinguished by the fact that more than one complimentary layer (12) between the base blanket (1) and the cover blanket (1) is eventually expected (12).

3) **IMPROVEMENT OF ANAEROBIC BIODIGESTER UTILIZED FOR BIOGAS CAPTATION**, according to claim 1, distinguished by the fact that it foresees transparent windows (17) on several strategic points of the cover blanket (2).

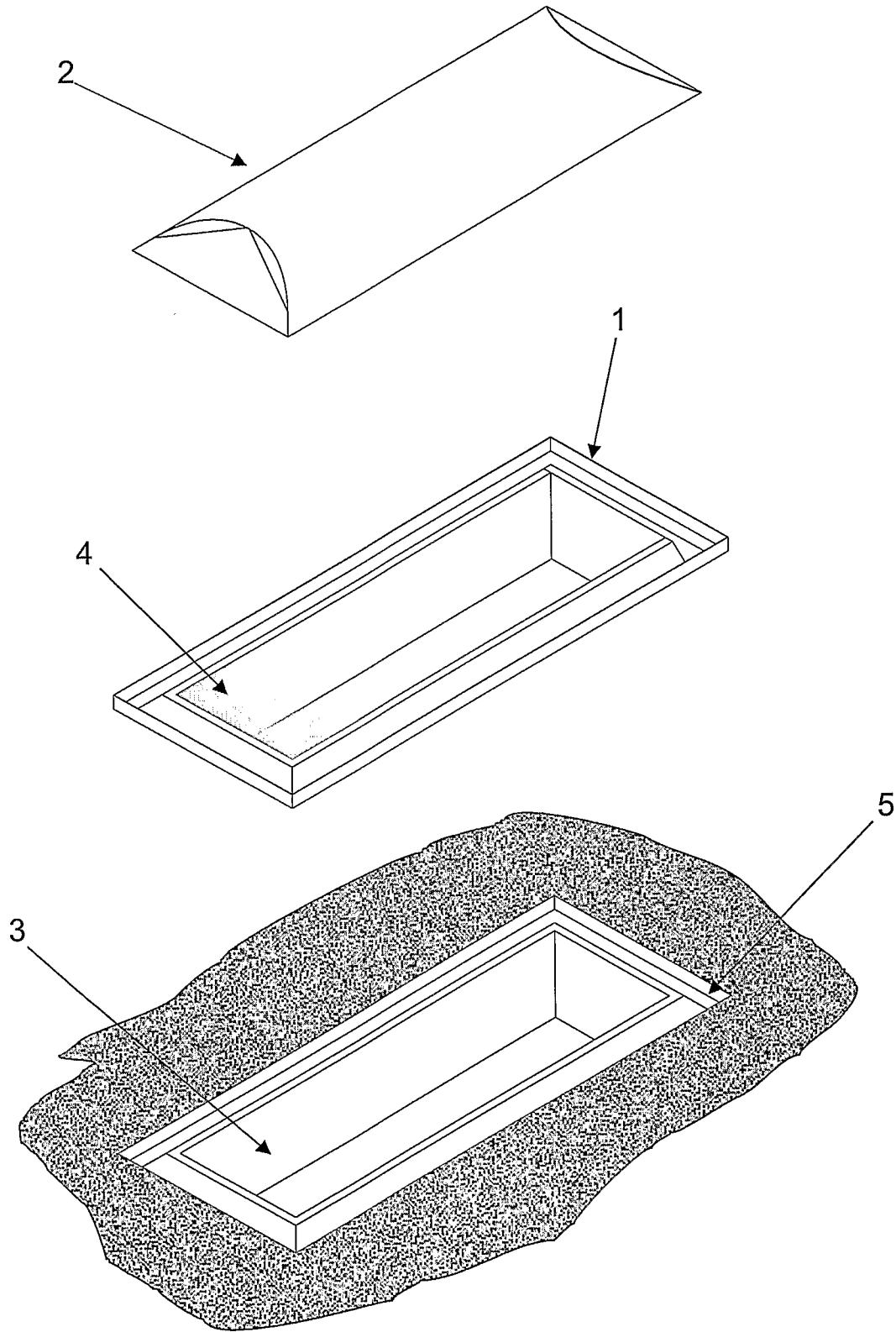

FIG. 1

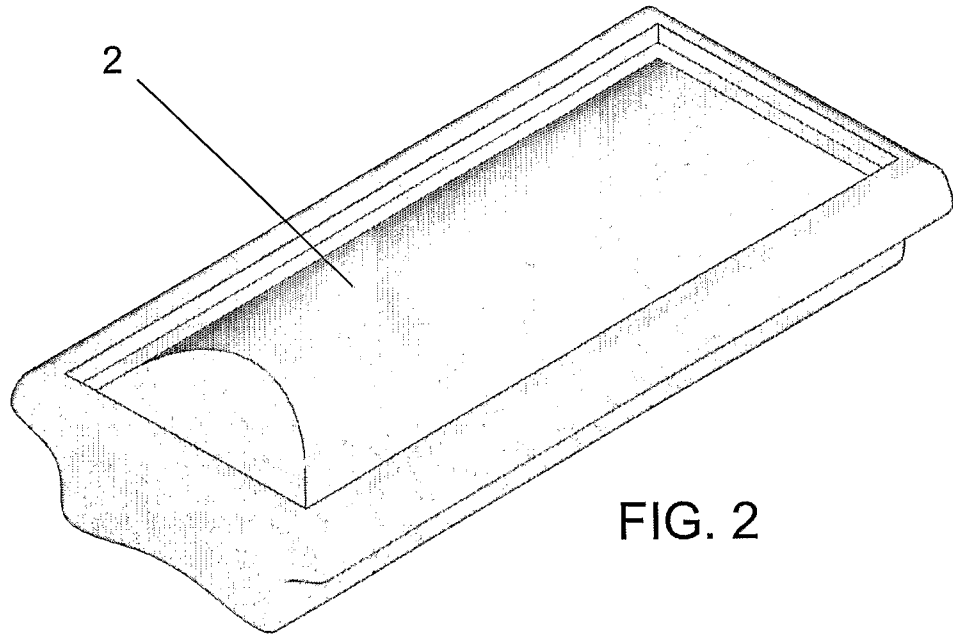

FIG. 2

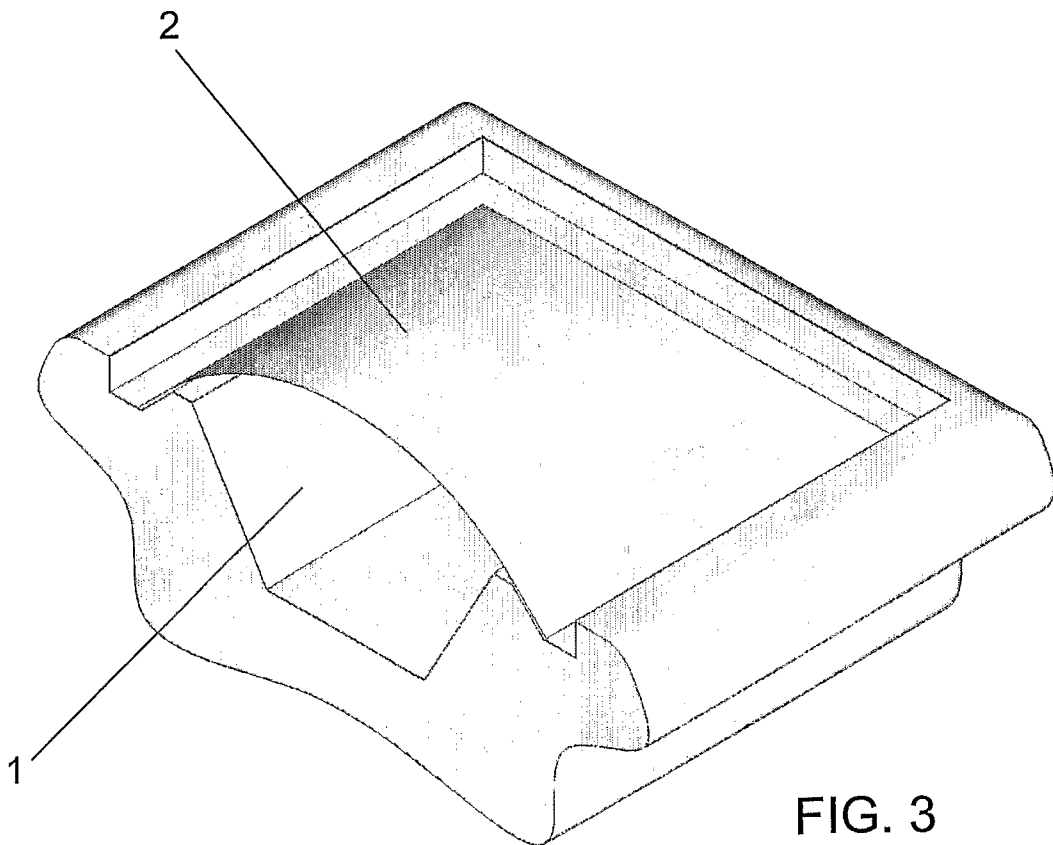

FIG. 3

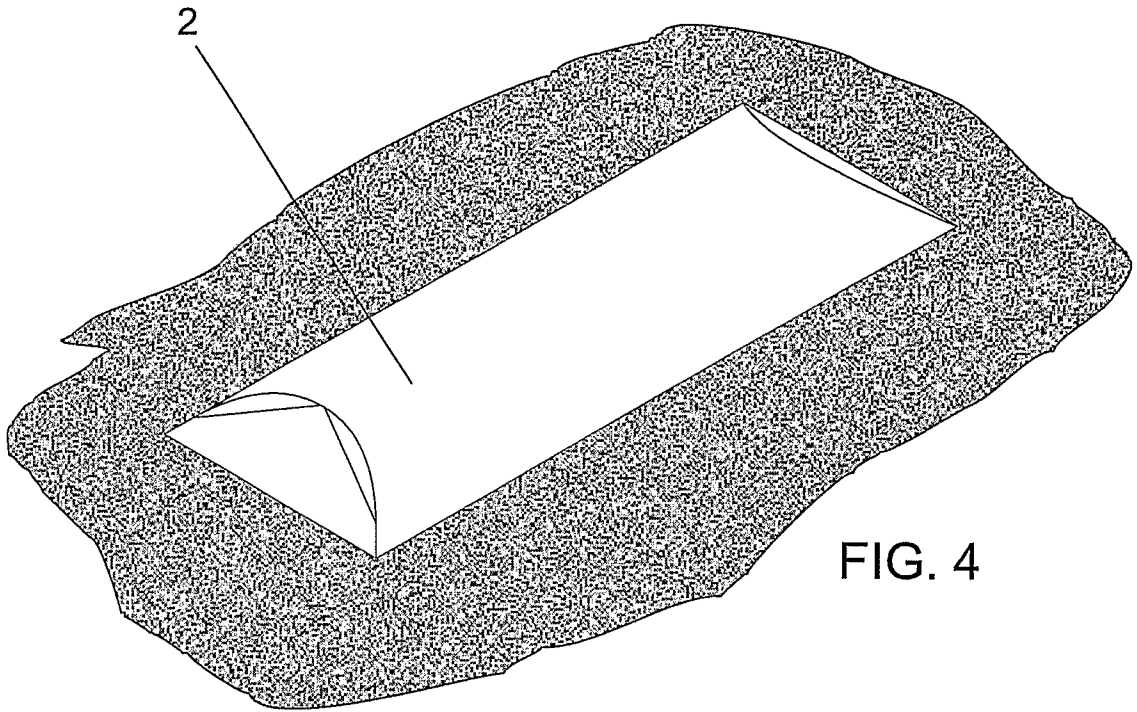

FIG. 4

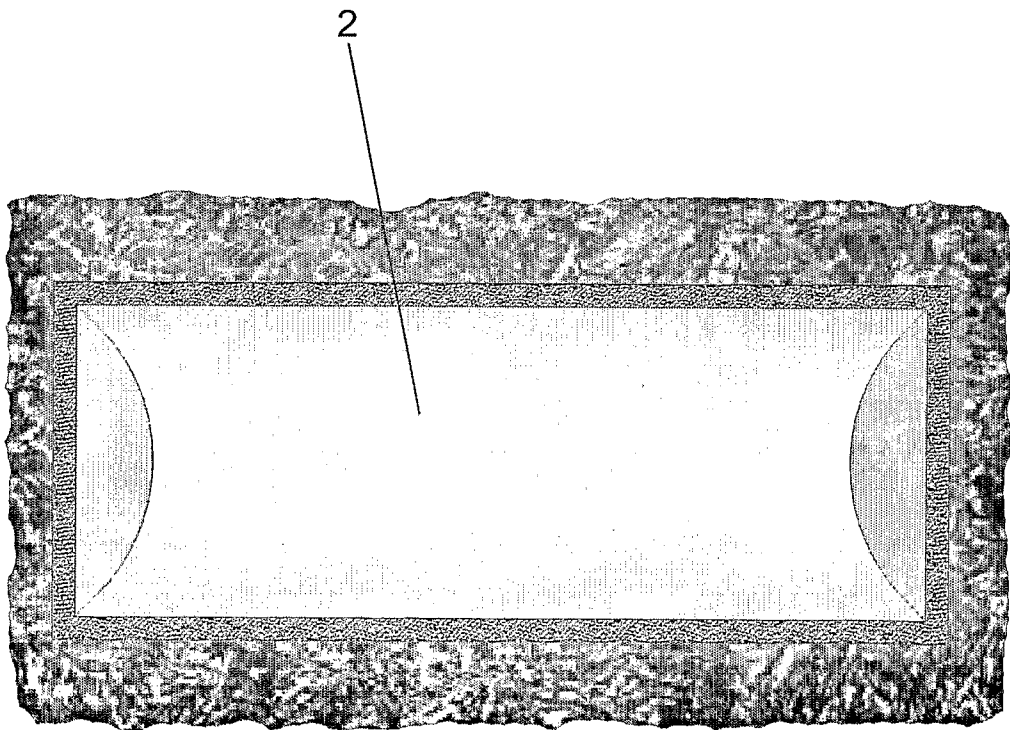

FIG. 5

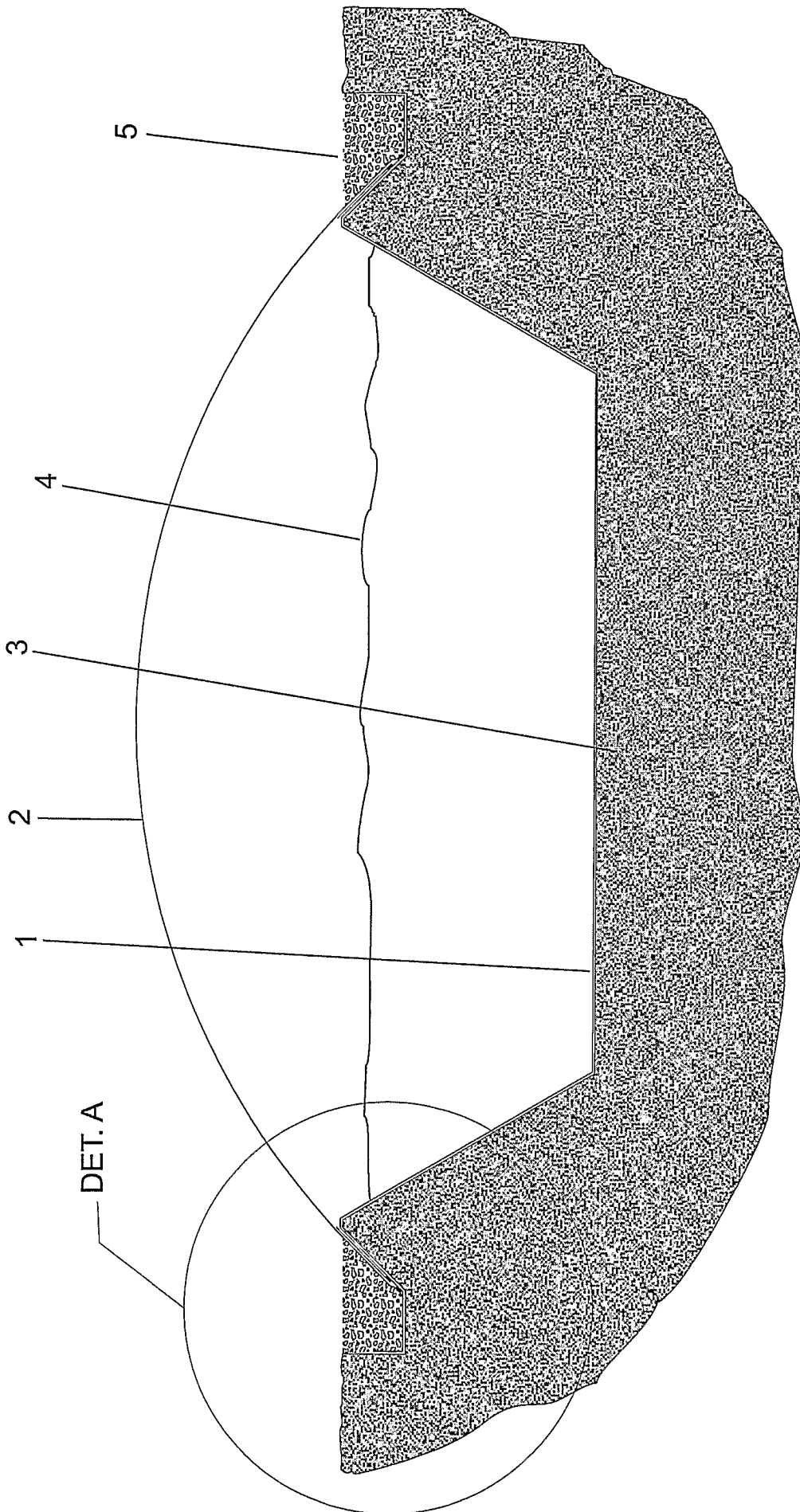

FIG. 6

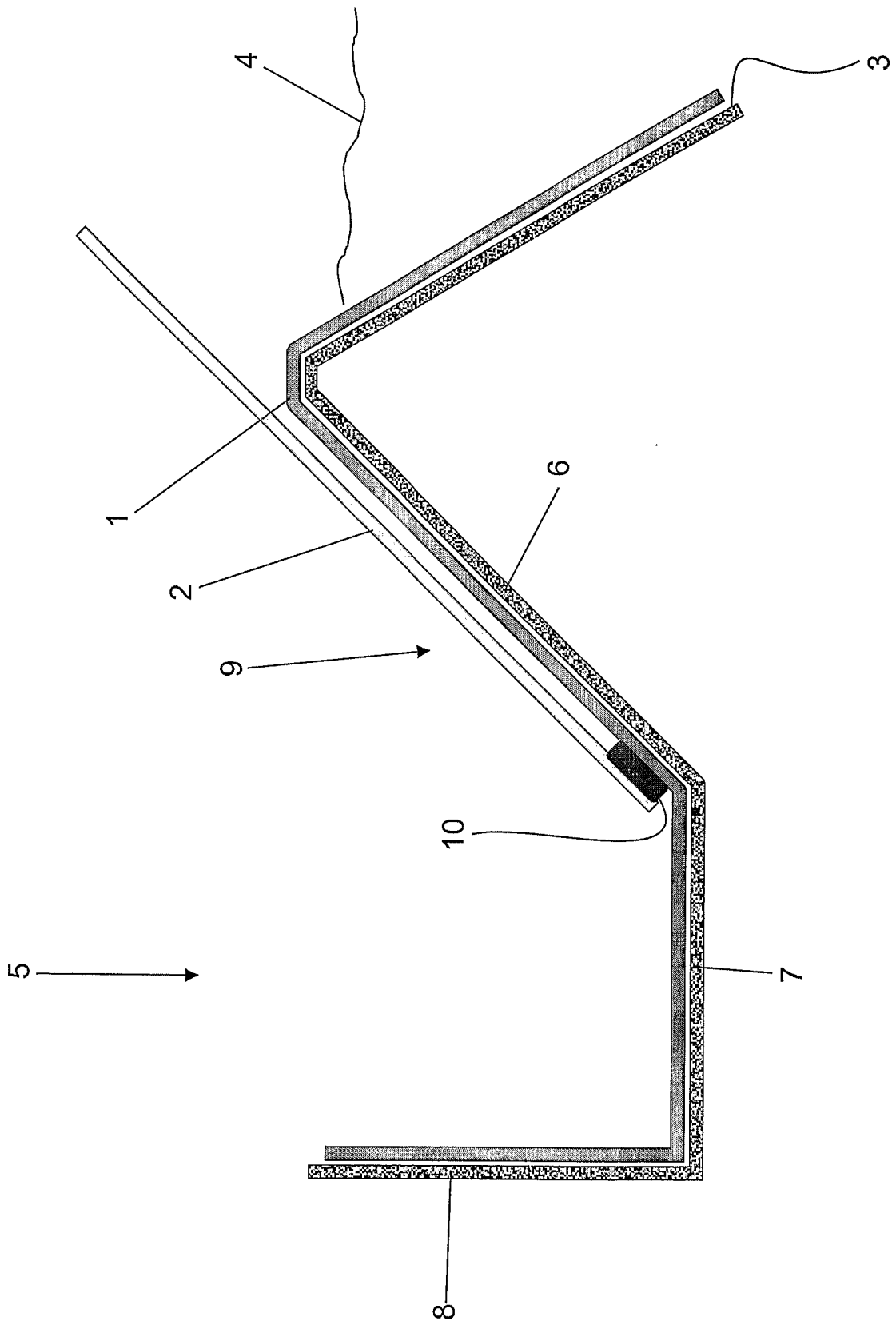

FIG. 7

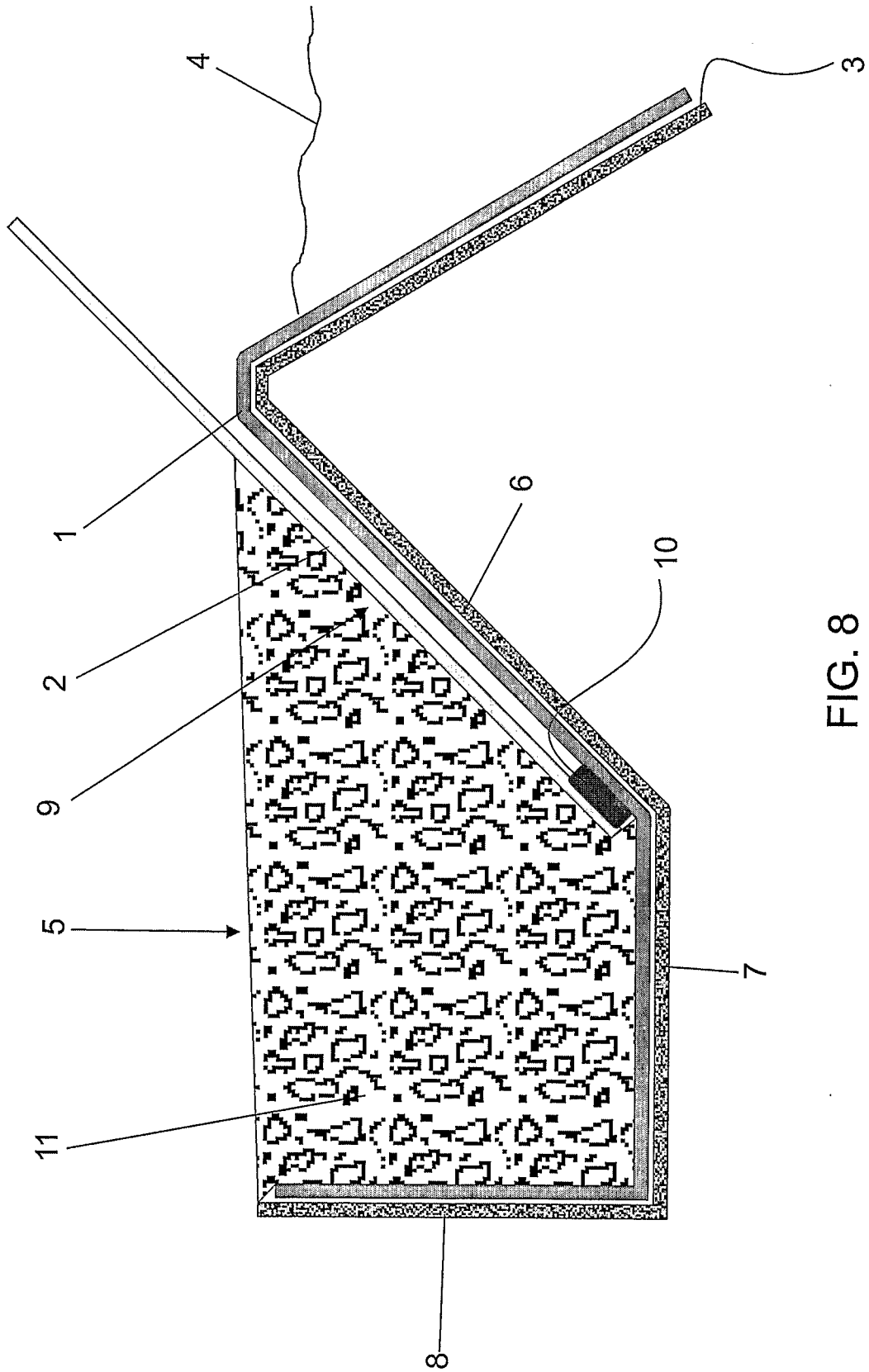

FIG. 8

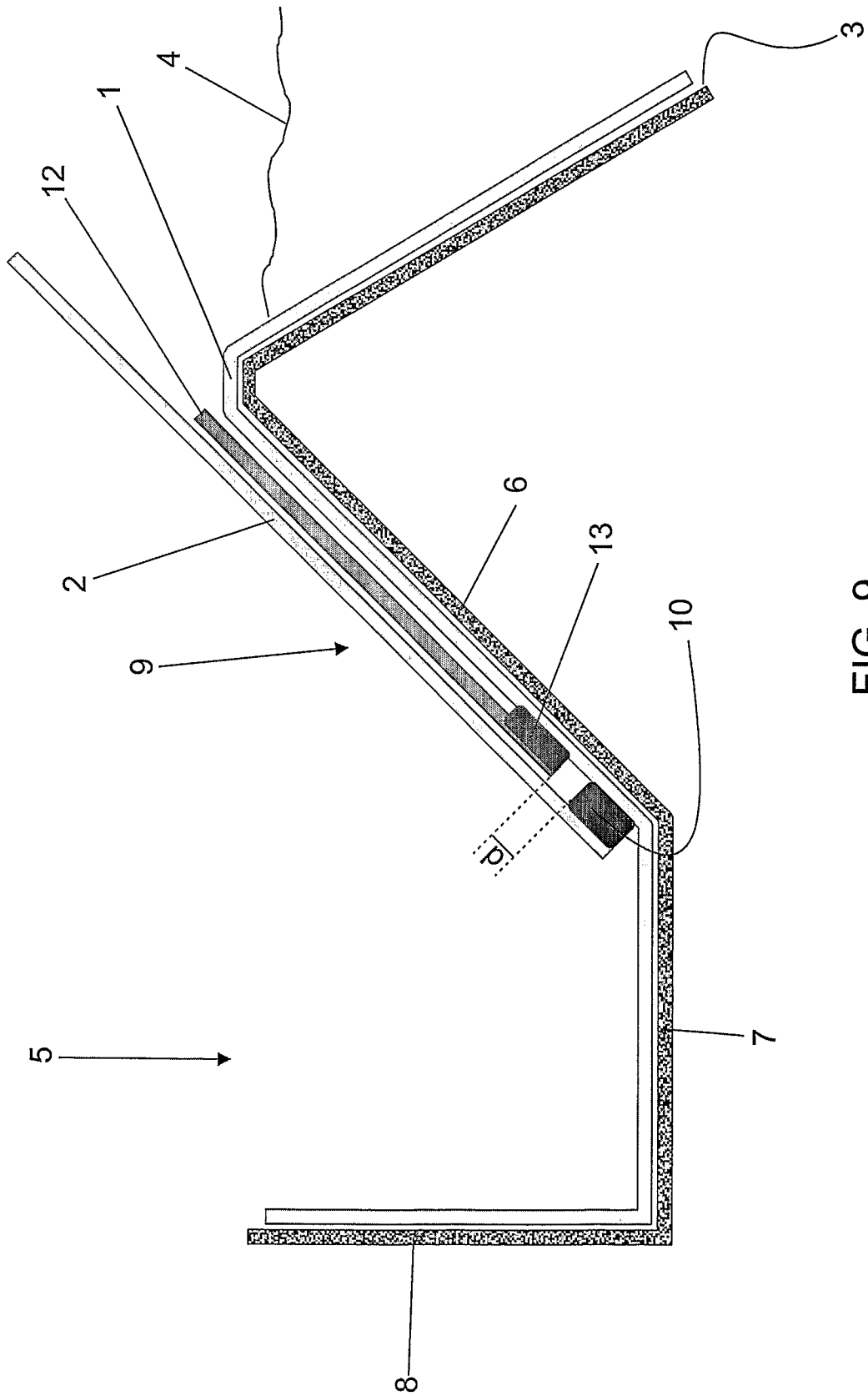

FIG. 9

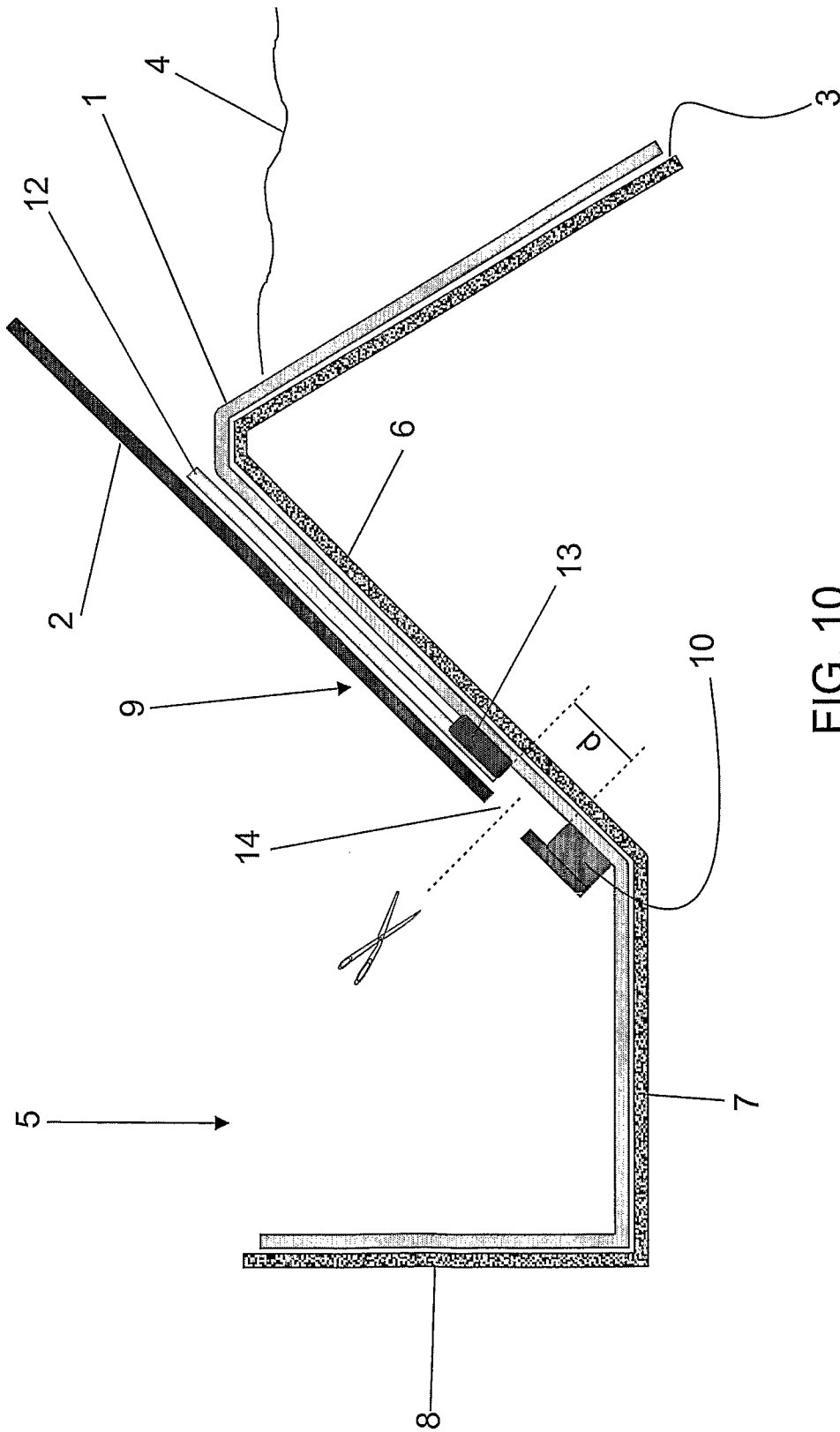

FIG. 10

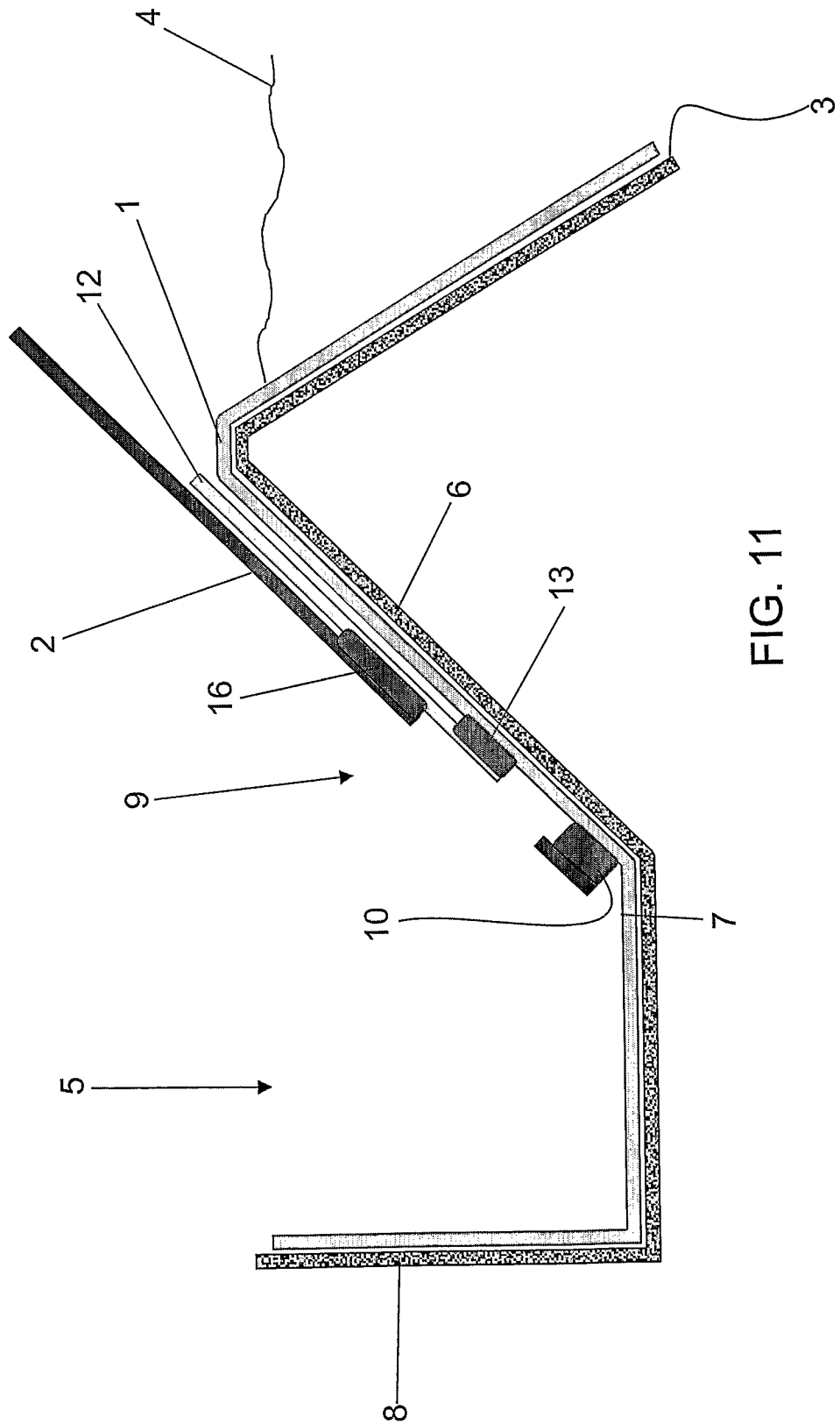

FIG. 11

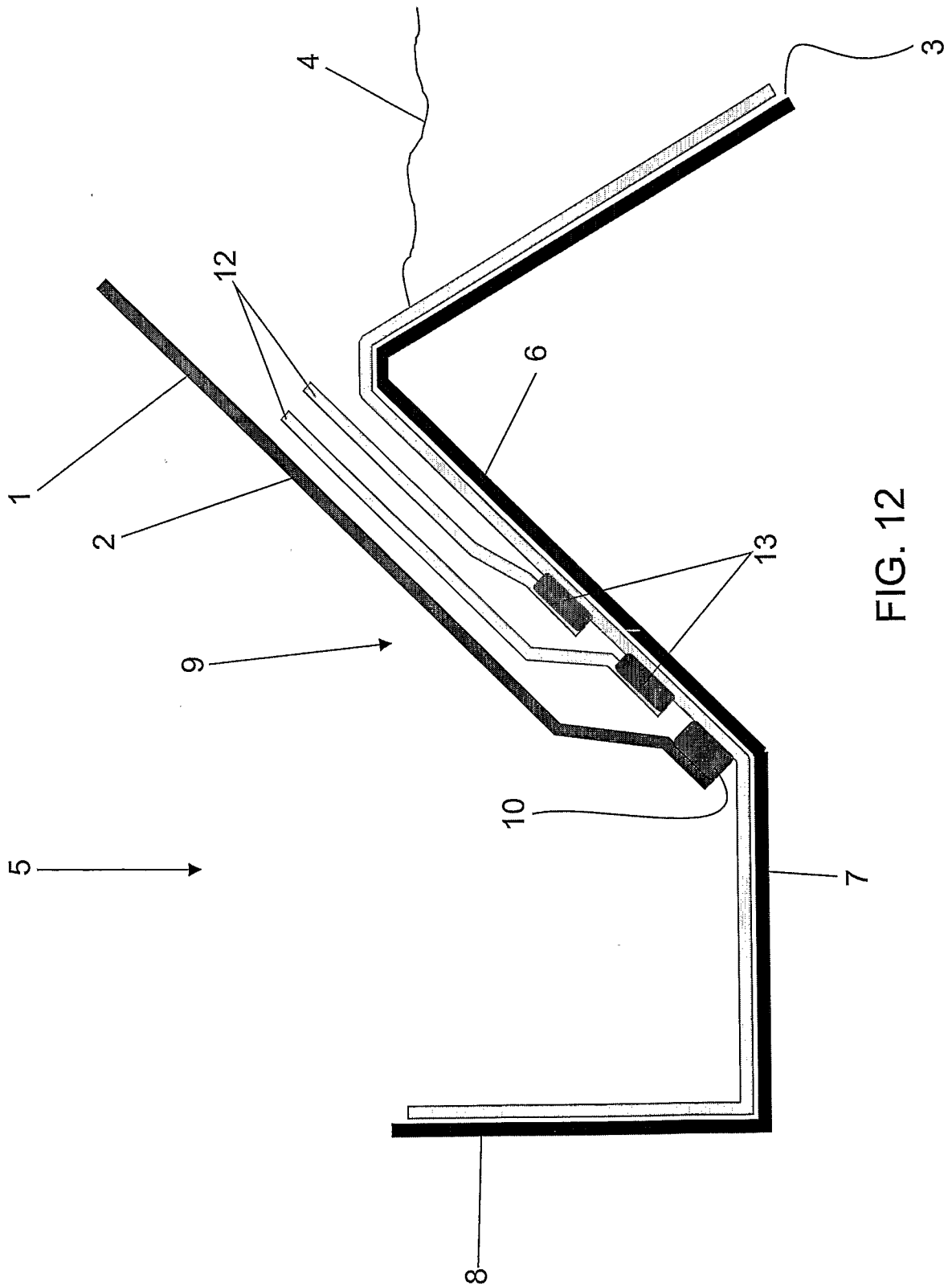

FIG. 12

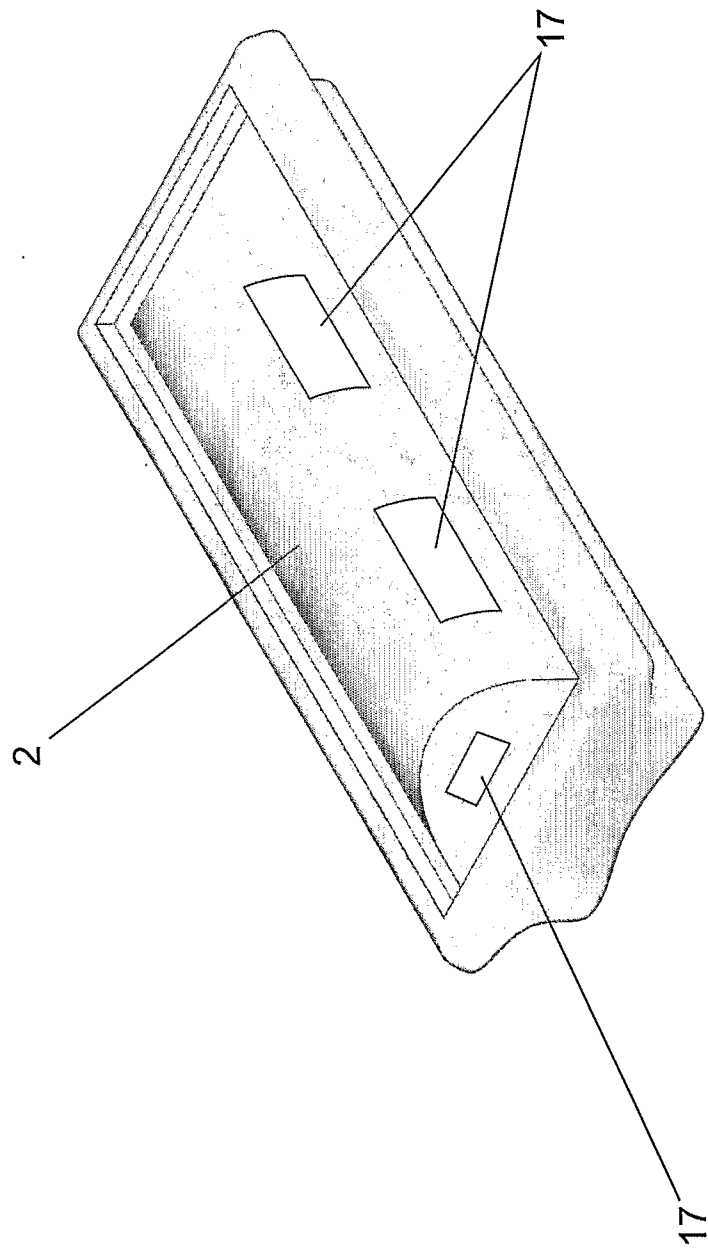

FIG. 13