

Dec. 13, 1960

O. E. COTE ET AL
BOX CONSTRUCTION

2,964,228

Filed Jan. 9, 1958

3 Sheets-Sheet 1

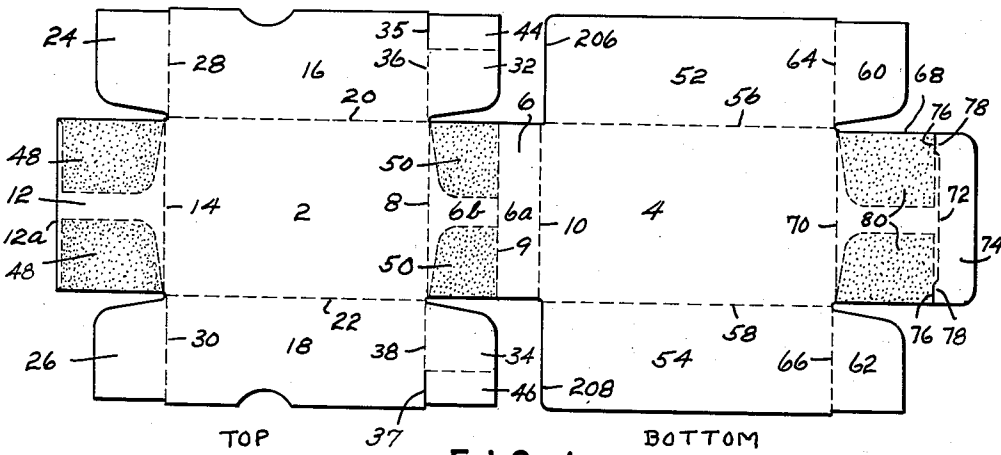

FIG. 1

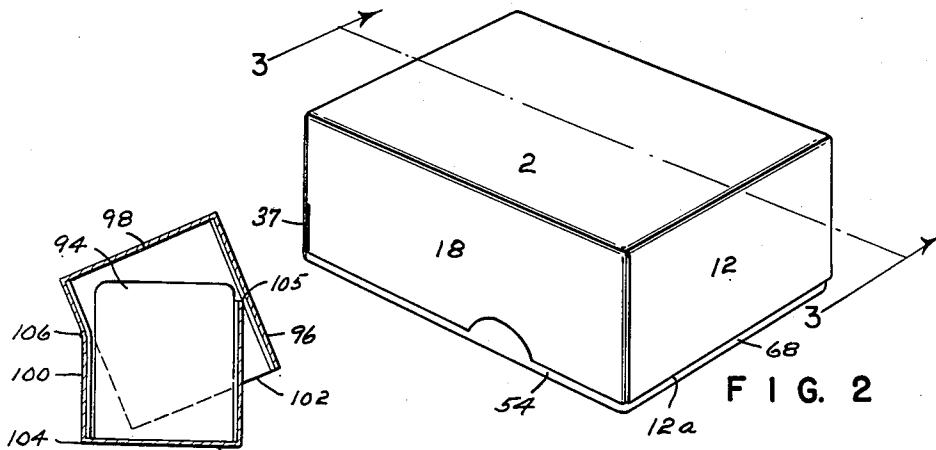

FIG. 2

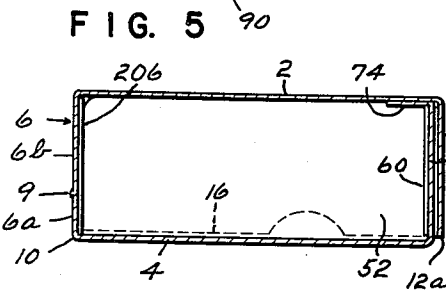

FIG. 3

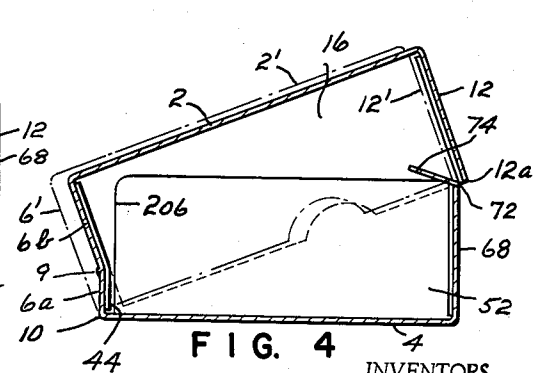

FIG. 4

INVENTORS
OMER E. COTE
OSKAR W. WIKSTROM
BY

Porter, Chittick & Russell

ATTORNEYS

Dec. 13, 1960

O. E. COTE ET AL
BOX CONSTRUCTION

2,964,228

Filed Jan. 9, 1958

3 Sheets-Sheet 3

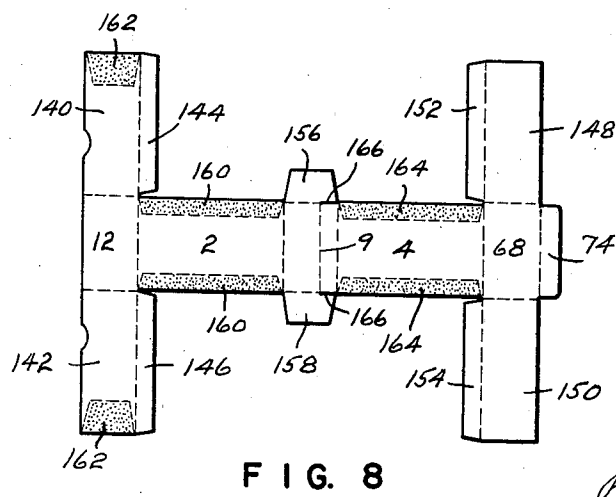
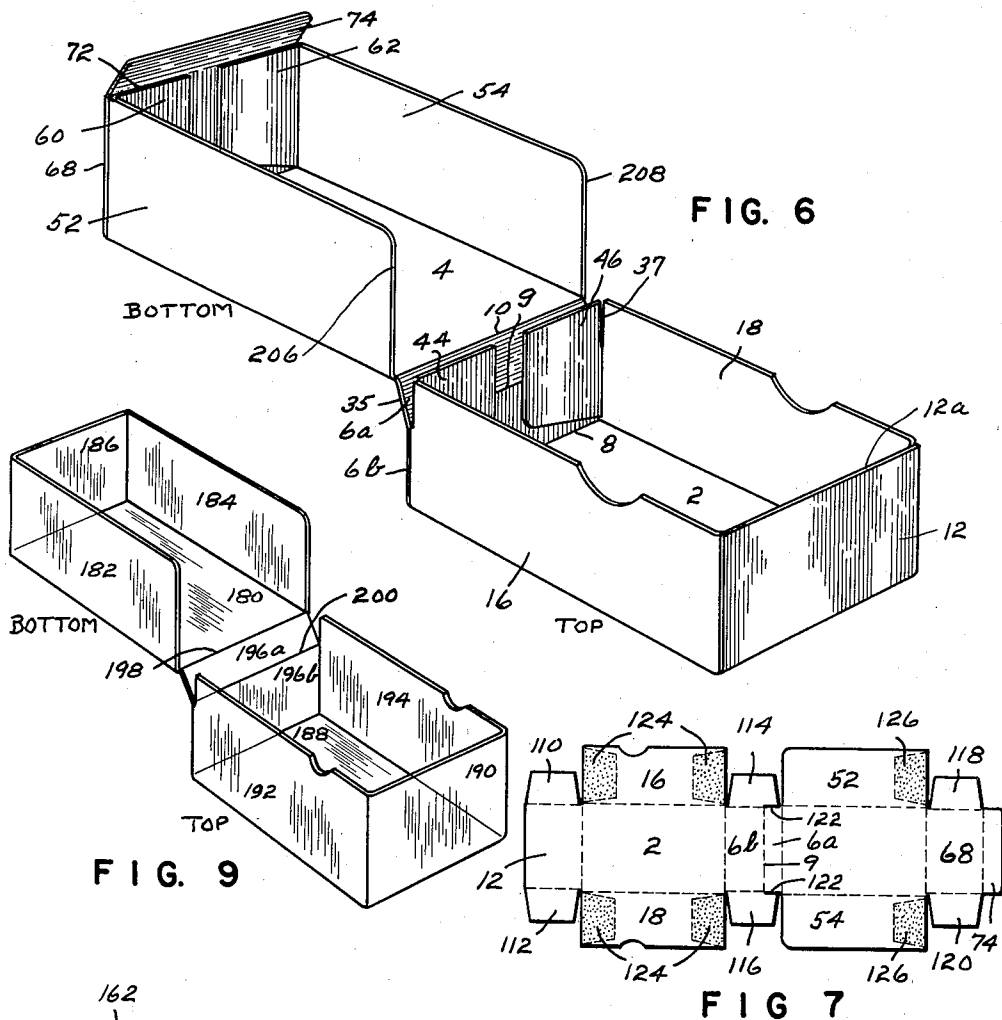

INVENTORS
OMER E. COTE
OSKAR W. WIKSTROM
BY

Porter, Chittick + Russell
ATTORNEYS

1

2,964,228

BOX CONSTRUCTION

Omer E. Cote, Providence, R.I., and Oskar W. Wikstrom, West Newton, Mass., assignors to United States Automatic Box Machinery Co., Inc., Boston, Mass., a corporation of Massachusetts

Filed Jan. 9, 1958, Ser. No. 707,925

1 Claim. (Cl. 229—33)

This invention relates to an improved form of box of the type comprising an article receiving section and a cover hinged to the article receiving section.

Boxes made of heavy paper, boxboard and the like and comprising an article receiving section and a cover section hinged to one of the wall panels of the article receiving section are well known in the art. One common form of box with respect to which the present invention constitutes an improvement is the type used for cigarette cartons, waxed paper, pastry and the like. This type of box usually consists of a bottom portion comprising four upstanding side panels and a bottom panel and a top portion hinged to one of the side panels comprising a top panel and a front flap or a top panel and three side panels. This type of box is popular because of its relatively low cost. However, since the cover opens very easily, it must be tied or otherwise secured if spilling of the contents is to be prevented. Moreover, to facilitate closing the box, the front side panel of the cover section usually is detached from the other two side panels so that in effect it is nothing more than a flap. In either construction the cover section provides so little reinforcement or support for the corresponding portions of the bottom section that this type of box cannot be used satisfactorily for heavier articles such as, for example, nuts, bolts and other hardware elements. The latter type of merchandise is usually contained in a box which, for the purposes of the present discussion, may be identified as a "telescope box." This type of box is made in two sections, each section comprising four side panels and a single end panel. The box is closed by inserting the open end of one section into the open end of the other section so as to place the two sections in telescoping relation. This type of box is relatively strong because of the reinforcement provided by the overlapping of the side panels of the two sections. However, these boxes also have disadvantages. One disadvantage is that the two sections must be fully separated in order to gain access to the contents and quite often one part is mislaid or damaged due to failure to replace it in its normal telescoping relation with the other section. Another disadvantage is that the two parts must be of different sizes so that one can be inserted into the other. This difference in size requires that the two parts be made from different blanks, fabricated separately and then combined to form the box. Still another disadvantage occurs where a large number of containers of this type are required as, for example, in a factory making screws, bolts, nuts, etc. In such case it is necessary to stock both sections of the box and to keep the sections segregated until the smaller section has been packed and is ready to receive the cover section. Another disadvantage is the ease with which contents may be spilled. If the outer or cover section is grasped without simultaneously supporting the inner section, the two parts may separate and the contents be spilled.

Accordingly, it is the general object of this invention to provide a box which combines the advantages of a pastry type box with the advantages of a telescope box

2

without having the disadvantages found in those forms of box construction.

A further object of the invention is to provide a box comprising a bottom article receiving section and a top cover section which is hinged to the bottom panel of the bottom section and includes an arrangement for holding the cover closed so that the contents will not be spilled accidentally.

A more specific object of the present invention is to provide a one-piece box made from paperboard, cardboard, plastic or the like comprising an article receiving section and a cover hinged thereto. The article receiving section has a bottom panel, a bottom end panel connected to one end of the bottom panel, and two bottom side panels connected to the bottom panel and the bottom end panel. The cover has a top panel, two cover side panels connected to opposite sides of the top panel, and two cover end panels connected to the end of the top panel and the cover side panels. The other end of said bottom panel is hingedly connected to the lower edge of one of the cover end panels, this latter cover end panel being separated from the cover side panels for a limited distance from the said hinged connection to provide a portion of the said one cover end panel which is free to bend outwardly along a line parallel to the hinged connection whereby the said portion may be flexed away from the said other cover end panel as the cover is closed over the article receiving section and whereby the free edge and all of the inner surface of the said other cover end panel may pass progressively over the upper edge of said bottom end panel with frictional effects hereinafter explained.

Fig. 1 is a plan view of a preferred form of cardboard blank employed to form a box according to the principles of the present invention.

Fig. 2 is a perspective view of a box formed from the blank of Fig. 1 with the cover in closed position.

Fig. 3 is a vertical section taken along line 3—3 of Fig. 2.

Fig. 3a is an enlargement of a portion of Fig. 3.

Fig. 4 is a vertical section similar to Fig. 3 but showing how the hinged end panel of the cover is flexed as the cover is moved to a closed or open position.

Fig. 5 is a sectional view similar to Fig. 4 showing the nature of the invention when used in connection with a box whose depth is substantially the same as its width.

Fig. 6 is a perspective view showing the box of Fig. 2 in completely open position.

Fig. 7 is a plan view of a second form of box blank embodying the present invention.

Fig. 8 is a plan view of a third form of box blank also embodying the present invention.

Fig. 9 is a perspective view similar to Fig. 6 of a one-piece molded box also embodying the present invention.

Fig. 10 is an enlarged perspective view of the box of Fig. 2 with the cover in substantially the same position as that occupied in Fig. 4.

Referring now to Fig. 1, there is illustrated a preferred form of blank fabricated from cardboard or paperboard for forming a box embodying the present invention. The blank comprises a rectangular top or cover panel 2 connected at its rear end to the corresponding end of a bottom panel 4 by means of an intermediate panel 6 which, for convenience, will generally be referred to as the top rear end panel of the cover of the box, but it should also be noted that panel 6 is an end panel which is common to both the cover section and the bottom section. The top rear end panel 6 is demarcated by score or crease lines 8 and 10 which function to facilitate bending of the top and bottom panels relative to the end panel 6. Running transversely of the top rear end panel 6 is a third score line 9. In the present em-

bodiment score line 9 is closer to the bottom panel 4 than it is to the top panel 2 and effectively subdivides panel 6 into two portions 6a and 6b. The vertical location of score line 9 may be varied according to the box dimensions and the degree of friction wanted for maintaining the cover section in closed position over the bottom section.

At its other end top panel 2 is provided with a top front end panel 12, the latter being demarcated by score line 14. Also formed integral with top panel 2 are two top side panels 16 and 18 which are demarcated by score lines 20 and 22. The two side panels 16 and 18 are provided at their forward ends with side flaps 24 and 26 demarcated by score lines 28 and 30 respectively. At their rear ends side panels 16 and 18 are provided with rear flaps 32 and 34 which are demarcated by score lines 36 and 38 respectively. It is to be noted that portions of the rear end flaps 32 and 34 are separated from side panels 16 and 18 by means of transversely extending slits 35 and 37 respectively. These slits are aligned with score lines 36 and 38. Rear flaps 32 and 34 are also provided with score lines 40 and 42 which run at right angles to score lines 36 and 38 and which form small tab portions 44 and 46 which can be bent relative to the flaps 32 and 34 respectively.

The top end panel 12 is provided with glue as shown at 48 which is used to secure the side flaps 24 and 26. The other top end panel 6 is also provided with glue at selected areas 50 between score lines 8 and 9. The glue at 50 is provided to secure portions of the flaps 32 and 34 to the end panel 6. The tabs 44 and 46 overlie the area 6a in unglued relation.

The bottom panel 4 is provided with side panels 52 and 54 which are demarcated by score lines 56 and 58. These side panels 52 and 54 are provided with front end flaps 60 and 62 which are delineated by score lines 64 and 66 respectively running at right angles to score lines 56 and 58. Bottom panel 4 is also provided with a front end panel 68, a score line 70 being provided to facilitate bending of the front end panel 68 relative to the bottom panel 4. The front end panel 68 is provided with a transversely extending score line 72 which terminates short of the opposite side edges of the panel and functions to delineate a flap 74 which can be bent back relative to the remainder of panel 68. Formed in bottom front panel 68 at its opposite edges are two substantially L-shaped slits 76 which are located to one side of score line 72. These slits extend straight in from the opposite edges for a predetermined distance and then extend forwardly and inwardly, terminating at the ends of score line 72 and forming locking tabs 78 at the opposite ends of flap 74. The top end panel 68 is also provided with glue at areas 80 for securing the end flaps 60 and 62.

Looking now to Fig. 6, the top cover section of the box is formed by bending side panels 16 and 18 relative to the top panel 2 along score lines 20 and 22 and by bending the flaps 24, 26, 32 and 34 relative to the side panels. The front end panel 12 is also bent relative to the top panel 2. The flaps 24 and 26 are glued to the top front end panel 12. The top panel 2 is also bent relative to the rear top end panel or common panel 6 and the flaps 32 and 34 are secured thereto at the limited glued areas 50 only so that the area 6a of panel 6 is free to flex away from the plane of area 6b.

The bottom article receiving section of the box is formed by bending the side panels 52 and 54 along score lines 56 and 58 and by bending the flaps 60 and 62 relative to the aforesaid side panels. The front bottom end panel 68 is bent along score lines 70 and 72 and the flaps 60 and 62 are secured to it by the glue provided at areas 80. At this point the box is as illustrated in Fig. 6. It is to be noted that the tab portions 44 and 46 which overlie area 6a are not secured thereto. Area 6a of the top end panel 6 is free to bend along the score line 9. It is to be noted also that when flap 74 is bent back along crease line 72 the latter in effect becomes the top

edge of the front panel of the bottom section of the box and is so referred to hereinafter. Bending back of flap 74 also causes locking tabs 78 to project forward slightly beyond the remainder of panel 68 (see Fig. 3a). When the bottom receiving section and the cover section are brought together as shown in Figs. 3, 4 and 10, the cover section will swing initially relative to the bottom section along score line 10. It is believed apparent that if all of end panel 6 were maintained in the same plane with the top pivoting solely along line 10 it would be impossible to close the box. This may be understood by reference to the dot dash line of Fig. 4 in which the unbent end panel is indicated at 6', the top panel at 2' and the front end panel at 12'. Under such conditions the front panel of the cover section would be obstructed by the top edge 72 of the front panel 68 of the bottom box section. However, because the tab portions 44 and 46 of side flaps 32 and 34 are not secured to area 6a of top rear end panel 6, the latter can function as two panels 6a and 6b which are hingedly connected along score line 9, and panel 6a is hinged to bottom panel 4 on score line 10. The lower panel 6a acts as a freely movable connecting link between the bottom panel 4 and the upper portion 6b of the end panel 6.

Thus when the cover section is pivoted from open position toward closed position or when the cover is closed and it is desired to open the box, area 6a of the top rear end or common panel 6 is brought into or remains in parallelism with panel 68 and the cover then during closing or opening pivots about score line 9. Putting it another way, the outward bending of area 6a in effect permits the bottom section to be shifted rearwardly relative to the cover section just enough to allow the bottom edge 12a of the top front panel 12 to clear the top edge 72 of the bottom front panel 68. Thereafter as closing of the cover progresses the top edge 72 of the bottom end panel presses against the inner surface of the top end panel 12 with first increasing friction and then decreasing friction, the maximum frictional effect occurring when that part of the front end panel 12 that is opposite hinge 9 is in engagement with top edge 72. In other words, by considering the dimensions of the cover, the hinge 9 may be so located intermediate the top and bottom edges of panel 6 that the lower edge of panel 12 can be made to clear the upper edge of panel 68 but thereafter during closing there is a substantial tight position or area that must be passed before the cover reaches final closed position. If the box were of rigid material, this could not be accomplished, but because of the flexibility of the boxboard or other material of which these boxes are made enough distortion can occur to permit forcing of the cover downward past the tight area. Conversely, in opening the box equal force must be exerted in the opposite direction. There is therefore provided by this construction an automatic locking mechanism which effectively prevents accidental opening and spilling of contents.

When the cover is closed the top rear panel 6 will have assumed a plane condition as shown in Figure 3. Figs. 4, 6 and 10 illustrate how portion 6a bends relative to portion 6b. In Fig. 4, as previously noted, the cover is shown in both solid and broken lines to emphasize how it moves forwardly relative to the bottom box section when top rear panel 6 is bent along line 9, thus making it possible for the cover to close as previously explained.

Fig. 6 shows the cover in open position after it has been rotated with respect to the bottom through an arc of 180 degrees. However, it is apparent that had the top been rotated through only 90 degrees the bottom would have been fully uncovered because the intermediate connecting link section 6a would have pivoted 90 degrees about line 10 to lie in the plane of bottom panel 4.

When in this position, the sides 16 and 18 would extend vertically and be beyond the ends 206 and 208 of sides 52 and 54. This arrangement is of advantage when

filling the bottom with merchandise as the box may be placed on a table with the bottom section flat thereon and the top or cover section standing on end 6 and beyond the end of the bottom section.

The portion 6a of the end panel acting as a connecting link makes it possible to use a cover having end and side walls as deep as those of the bottom since it permits the cover to start closing over the upper edge of the bottom end wall without initial box distortion to be followed by the frictional self-locking characteristic heretofore explained.

The locking tabs 78 function to keep the cover fully closed. The tabs 78 cooperate with and overlies the upper edges of flaps 24 and 26 to hold the top and bottom together. In opening the box, however, the tabs may readily be pulled out of locked position. The locking construction can be seen more clearly by reference to Figs. 6 and 3a. In Fig. 6 the top edges of flaps 24 and 26 are spaced sufficiently from top panel 2 of the cover to accommodate locking tabs 78. When the cover is pivoted to closed position the flaps 24 and 26 engage tabs 78 and thereby cause flap 74 to pivot clockwise (as seen in Fig. 4). Flap 74 pivots enough to permit flaps 24 and 26 to slide down past tabs 78. However, when the top panel 2 of the cover engages flap 74, it rotates the flap counterclockwise thereby moving tabs 78 into the space between flaps 24 and 26 and top panel 2. When tabs 78 are in this position (Figs. 3 and 3a), they act with flaps 24 and 26 to hold the cover and bottom sections of the box together in final closed condition.

It is pointed out, however, that the tabs are simply an auxiliary means for holding the parts in the maximum closed position. The principal feature of the invention is the hinge arrangement which results in the substantial frictional effect between the end panels as the lid is closed or opened. This frictional effect, which occurs while the lid is swinging through a substantial angle on the way to complete closed position, prevents accidental opening in the manner previously explained.

Fig. 5 illustrates a cardboard box formed from a blank similar in shape to the blank employed to form the box of Fig. 2, but differing therefrom in dimensions. The height of the box of Fig. 5 is substantially the same as its depth measured from front to back, whereas in the box of Fig. 2 the depth is substantially greater than the height. In the box of Fig. 5 the bottom section comprises a bottom panel 90, a front panel 92 and two opposed side panels 94, only one of which is shown. The side panels are secured to the front and bottom panels. The box also includes a cover section comprising a front panel 96, a top panel 98, a back panel 100 and a pair of opposed side panels 102. Although only one of the side panels 102 is shown, it is to be understood that both of them are secured to front panel 96 and top panel 98. The bottom edge of back panel 100 is hinged at 104 to the back edge of bottom panel 90. The back panel 100 is also creased or scored horizontally at 106 so as to be bendable upon itself. Above the level of score line 106, back panel 100 is attached to side panels 102; below score line 106 it is not attached to side panels 102. From a comparison of Figs. 4 and 5 it will be seen that the deeper the box relative to its length the higher must be the hinge point of the cover if the lower edge of the front panel of the top is to clear the top edge of the bottom front panel and the proper frictional effect is to be obtained between the inner surface of the top end panel and the upper edge of the bottom end panel. As shown in Fig. 5, the cover in closing is approaching the point of maximum friction with upper edge 105 of the bottom end panel 92.

Fig. 7 illustrates a second form of box blank. This second form is similar to the box blank of Fig. 1 and accordingly identical numerals are used for corresponding parts. The differences are emphasized by numerals not common to Fig. 1. One difference is that the top side panels 16 and 18 and the bottom side panels 52 and 54

do not have end flaps. Instead top front panel 12 is provided with two side flaps 110 and 112, rear top panel 6 is provided with two side flaps 114 and 116, and bottom front panel 68 is provided with two side flaps 118 and 120. The side flaps 114 and 116 are partially detached from rear top panel 6 by means of slits 122 which extend from the rear edge of bottom panel 2 to the fold line 9. Another difference is that the end panels 6, 12 and 68 are not coated with glue. Instead glue 124 is applied to both ends of panels 16 and 18 and additional glue 126 is applied to the front ends of side panels 52 and 54. The flaps 110, 112, 114 and 116 are glued to panels 16 and 18 to set up the cover and flaps 118 and 120 are glued to side panels 52 and 54 to set up the bottom of the box. As with the box formed from the blank of Fig. 1, when the cover and bottom of the box formed from the blank of Fig. 7 are swung toward and away from each other the top rear panel 6 bends along crease line 9 to permit the panel 12 to slide past the panel 68. Bending of panel 6 along crease line 9 is rendered possible due to the fact that the portion 6a is not attached to side panels 16 and 18 by means of flaps 114 and 116, the latter being detached from portion 6a by the slits 122. The flap 74 of Fig. 7 is not provided with tabs 78 previously described since in this construction there are no cooperating flaps on the inside of the top front end panel with which tabs 78 might engage.

Fig. 8 illustrates a third form of box blank. In Fig. 8 parts corresponding to parts in the box blank of Fig. 1 are identified by identical numerals and those parts or features which are different are identified by different numerals. In Fig. 8 the top side panels 140 and 142 are formed integral with the sides of top front end panel 12 and are provided along their top edges with flaps 144 and 146 respectively. The two bottom side panels 148 and 150 are formed integral with the sides of bottom front end panel 68 and are provided at their bottom edges with flaps 152 and 154 respectively. The top rear end panel 6 is provided with two flaps 156 and 158 at its opposite side edges. In setting up the cover top side panels 140 and 142 are bent at a right angle to panel 12 and the latter is bent at a right angle to top panel 2. Flaps 144 and 146 are bent at right angles to top side panels 140 and 142 and secured to top panel 2 by means of glue 160 applied along the side margins of the top panel. Panel 2 in turn is bent at a right angle to top rear panel 6 to place top side panels 140 and 142 in position to be secured by flaps 156 and 158. The latter, after being bent at a right angle to top rear panel 6, are secured by glue 162 to the rear ends of side panels 140 and 142. The bottom is set up in a similar fashion, flaps 152 and 154 being secured to the side margins of bottom panel 4 by means of glue 164. It is to be noted that flaps 156 and 158, like the flaps 114 and 116 of Fig. 7, are partially detached from top rear panel 6 by means of slits 166 which extend from the rear edge of bottom panel 2 to the crease line 9. Thus when the cover and bottom sections are brought together top rear panel 6 can bend along crease line 9 to permit the box to be fully closed.

The present invention is not confined to boxes made of paperboard or cardboard and may be embodied in boxes constructed of other materials such as plastic. Fig. 9 illustrates a box made of plastic. Although polyethylene plastic is preferred due to its flexibility, it is recognized that other plastics well known to persons skilled in the art may be employed instead. The advantage of a plastic box is that it requires no flaps to hold the side panels together and, therefore, the interior surfaces of the cover and bottom sections of the box are smooth throughout. Other advantages are strength and ease of manufacture using conventional high speed molding machines.

From a comparison of Fig. 9 with Fig. 6, it is quite clear that the boxes shown in those figures both embody the same invention. In Fig. 9 the bottom section comprises a bottom panel 180, two side panels 182 and 184, and a

front end panel 186. The cover consists of a top panel 188, a front end panel 190, two side panels 192 and 194, and a rear panel which comprises two portions 196a and 196b. Portion 196b is attached to the rear end edges of top side panels 192 and 194 and top panel 188. The side edges of portion 196a are not attached to either the top or bottom side panels but the bottom edge is attached to the rear edge of bottom panel 180. Because of the flexibility inherent in polyethylene or other equivalent materials of which the box may be made, the bottom panel 180 can pivot relative to portion 196a along the line of juncture 198 and portion 196a in turn can pivot relative to portion 196b along the line of juncture 200. If necessary, pivoting can be facilitated by scoring or reducing the thickness of the plastic material along the aforesaid lines of juncture. In opening and closing the box the portion 196a of the top rear panel is free to affect rearward relative movement of the bottom section by an amount sufficient to permit the top front panel 190 to slide over the bottom front panel 186.

It should also be observed that in all forms disclosed the bottom section, when the box is closed, cannot shift longitudinally with respect to the top section in the direction of the top rear end panel. This is so because of the engagement of the rear edges of the bottom side panels with the inner face of the top rear end panel. Referring to Figs. 1 and 3, for example, the bottom section cannot shift to the left with respect to the top section for the left edges 206 and 208 of panels 52 and 54 will engage the inside of top rear end panel 6 at the upper part 6b which is secured to the top side panels 16 and 18. In other words, the construction permits hinge action at line 9 only during opening or closing of the top section.

In the box made from the blank of Fig. 1 and as illustrated in Figs. 4 and 10, the outside edges of tabs 44 and 46 also help to fill the small space that may be present between vertical edges of area 6a and the adjacent vertical edges of bottom side panels 52 and 54.

It is our intention to cover all changes and modifications of the example of the invention herein chosen for purposes of the disclosure which do not constitute departures from the spirit and scope of the invention.

We claim:

A one-piece box having a cover section and a bottom section, said cover section comprising a top panel, front and rear end walls and two side walls, means connecting said side walls to said front and rear walls, said bottom section having a bottom panel, two side walls and a front end wall of substantially the same vertical

dimension as the end walls of said cover section, said bottom side walls standing free and unconnected at and for the full length of their rear edges, the rear end wall of said cover section acting as the closure for the open end of said bottom section when said cover section has been placed in closed position on said bottom section, the lower edge of said rear cover end wall being hingedly connected to said bottom panel at said open end whereby said cover section can be swung at right angles to said bottom section in which position said rear cover end wall will be aligned with said bottom panel to present an enlarged continuous flat area with the free edges of said cover section side walls being closely adjacent the end edges of said bottom section side walls, the lower portion of said rear cover end wall being independent of the adjacent end edges of said cover section side walls for a limited distance from the lower rear corner of said side walls so that said lower portion only of said rear wall is bendable away from the rear edges of said cover side walls along a line of flexure parallel to the said hinged connection of said rear cover end wall with said bottom panel, said line of flexure being intermediate the top and bottom edges of said rear cover end wall whereby during the closing of said cover section over said bottom section and with the said lower portion of the said rear cover end wall in parallel relationship with the front end wall of said bottom section, the distance from said line of flexure to the lower edge of said front end wall of the cover section will be such as to permit said front cover end wall to be moved downwardly over the upper edge of the front end wall of the said bottom section and the interior surface of said front cover end wall will thereafter frictionally engage the upper edge of said bottom front end wall as said cover is moved to closed position.

References Cited in the file of this patent

UNITED STATES PATENTS

271,975	Quildfeldt	Feb. 6, 1883
639,269	McMillin	Dec. 19, 1899
1,046,398	Morrison et al.	Dec. 3, 1912
2,141,752	Hoarle	Dec. 27, 1938
2,839,236	Dunning	June 17, 1958
2,870,952	Ringler	Jan. 27, 1959

FOREIGN PATENTS

32,754	Norway	July 25, 1921
--------	--------	---------------