

(No Model.)

G. F. HUTCHINS & W. D. THOMPSON.
TAKE-UP MECHANISM.

No. 595,103.

Patented Dec. 7, 1897.

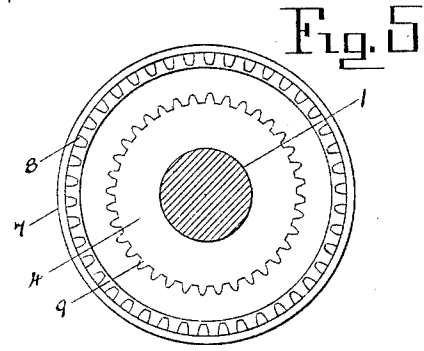
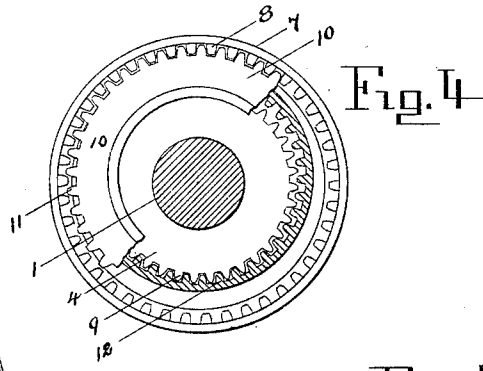
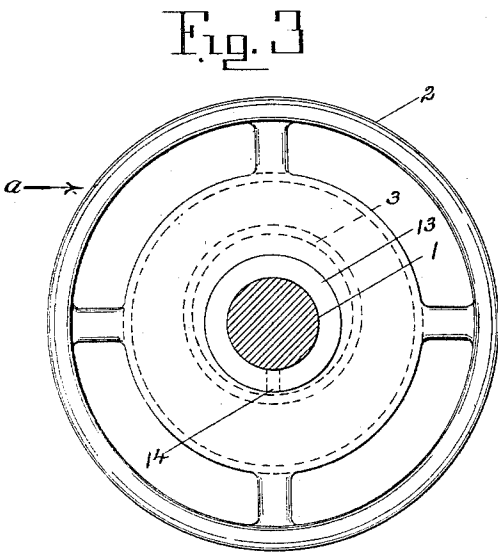
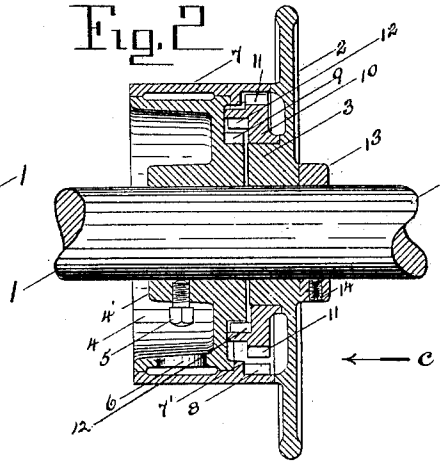
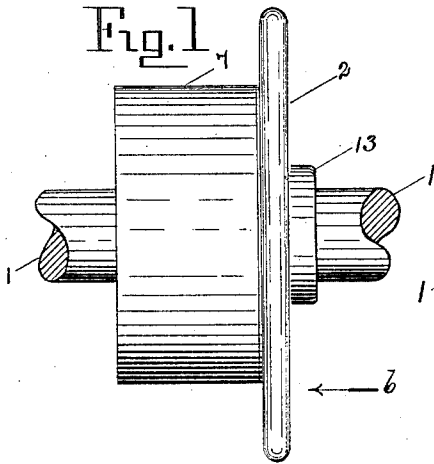

Witnesses:
Arthur S. Cowan.
Wm. L. Chase

Inventors:
George F. Hutchins
William D. Thompson
By John C. Dewey -
Attorney

UNITED STATES PATENT OFFICE.

GEORGE F. HUTCHINS AND WILLIAM D. THOMPSON, OF WORCESTER, MASSACHUSETTS, ASSIGNORS TO THE CROMPTON & KNOWLES LOOM WORKS, OF SAME PLACE.

TAKE-UP MECHANISM.

SPECIFICATION forming part of Letters Patent No. 595,103, dated December 7, 1897.

Application filed April 12, 1897. Serial No. 631,741. (No model.)

To all whom it may concern:

Be it known that we, GEORGE F. HUTCHINS and WILLIAM D. THOMPSON, citizens of the United States, residing at Worcester, in the county of Worcester and State of Massachusetts, have invented certain new and useful Improvements in Take-up Mechanisms, of which the following is a specification.

Our invention relates to a take-up mechanism, and is designed more particularly to be used in connection with narrow-ware looms. In this class of looms a series of take-up rolls are mounted on a common take-up shaft and revolve with said shaft to take up or wind up the fabric as it is woven, and each take-up roll is adapted to be revolved in either direction independently of the take-up shaft in case of a shuttle-thread breaking, or for any other reason.

Different mechanisms have been used for connecting the take-up rolls with the common take-up shaft to cause them to revolve therewith and for disconnecting them to cause them to revolve independently thereof; and the object of our invention is to provide an improved take-up mechanism which is preferably made entirely of metal and is of simple construction.

Our invention consists in certain novel features of construction of our take-up mechanism, as will be hereinafter fully described.

Referring to the drawings, Figure 1 is an edge view, looking in the direction of arrow *a*, Fig. 3, of a take-up roll and hand-wheel mounted on a shaft and provided with our take-up mechanism or mechanism for connecting the take-up roll to the shaft or disconnecting it therefrom. Fig. 2 is a central vertical section of the roll and hand-wheel shown in Fig. 1. Fig. 3 is a side view looking in the direction of arrow *b*, Fig. 1. Fig. 4 is a side view looking in the direction of arrow *c*, Fig. 2, the hand-wheel being removed, showing the arrangement of gear-teeth. One of the gear-teeth rims is partially broken away or shown in section to show the gear-teeth under the same. Fig. 5 corresponds to Fig. 4, but the gear-teeth rim shown in Fig. 4 is removed.

In the accompanying drawings, 1 is a por-

tion of a driven shaft, which may be the take-up shaft of a narrow-ware loom. 2 is a hand-wheel loosely mounted on said shaft and having an eccentric-hub portion 3. A shell 4, having a hub 4', is secured on the shaft 1, contiguous to the hub 3 of the hand-wheel 2, by a set screw or bolt 5. (See Fig. 2.) In order to obtain access to the bolt 5 to turn it in or out, we preferably have a hole 6 through the periphery of the shell 4. (See Fig. 2.)

Upon the shell 4 is mounted, to turn freely thereon, the take-up roll or drum 7, which is provided with internal gear-teeth 8 at the edge adjacent to the hand-wheel 2. (See Fig. 2.) The shell 4 is provided with external gear-teeth 9 on the end adjacent to the eccentric-hub 3 of the hand-wheel 2. (See Fig. 2.)

Within the inner end of the take-up roll or drum 7 is arranged what may be termed a "combination gear-rim" 10, having a central concentric opening, into which extends the eccentric portion 3 on the hand-wheel 2. The combination gear-rim 10 has external gear-teeth 11 on the periphery thereof, the number of which is less than the number of teeth 8 in the drum 7, and said teeth are adapted to engage and mesh with said teeth 8, as shown in Fig. 4. The combination gear-rim 10 has also internal gear-teeth 12, the number of which is greater than the teeth 9 on the shell 4, and are adapted to mesh with said teeth 9. (See Fig. 4.) The combination gear-rim 10 is made to turn freely on the eccentric-hub portion 3 of the hand-wheel 2, and the gear-teeth 11 and 12 thereon are concentric with the central opening in said gear-rim.

A collar 13, secured on the shaft 1 by a screw 14, holds the hand-wheel 2 in place against the inner edge of the take-up roll or drum 7 and the take-up roll or drum 7 in place on the shell 4. An internal annular flange 7' on the drum 7 extends over the inner edge of the periphery of the shell 4. (See Fig. 2.)

The eccentricity of the hub portion 3 of the hand-wheel 2 is equal to the length of a tooth on the combination-gear 10 plus any additional amount for clearance. (See Fig. 4.)

The operation of our take-up mechanism will be readily understood by those skilled in

the art from the above description in connection with the drawings.

When the shaft 1 revolves in the ordinary operation of the loom, the shell 4, fast thereon, will revolve with it and will carry the drum or take-up roll 7 and the hand-wheel 2 through the combination-gear 10, loosely mounted on the eccentric portion 3 of the hand-wheel 2. When it is desired to cause the take-up roll or drum 7 to turn in either direction independently of the shaft 1, said shaft continuing to revolve, the hand-wheel 2 is turned in one direction or the other, according to whether it is desired to turn the take-up roll or drum 7 forward or back. When the hand-wheel 2 is revolved in either direction, said hand-wheel being loose on the shaft 1, as above stated, the eccentric portion 3 thereon revolves within the concentric central opening in the combination-gear 10 and moves said gear so that the internal gear-teeth 12 will be engaged continually with the gear-teeth 9 on the shell 4 through any movement of the eccentric and hand-wheel, and it will be noticed that by one revolution of the hand-wheel 2 and the eccentric portion 3 thereon all the gear-teeth 9 have been engaged by the gear-teeth 12, and if there are one or more gear-teeth 12 than there are gear-teeth 9 the movement of the combination-gear 10 will be advanced beyond its original position by the difference in the number of teeth between teeth 9 and 12. An operation of a similar nature will take place between the gear-teeth 8 and the gear-teeth 11 during the same revolution of the hand-wheel, and there being more teeth 8 than there are teeth 11 they will be advanced or moved forward in the same direction around the teeth 11 as the teeth 12 are advanced around the teeth 9, and the movement of the take-up roll or drum 7 independently of the shaft 1 for one revolution of the hand-wheel 2 and eccentric-hub 3 thereon will be equal to the combined advancement of the gears 12 and 8, above referred to. The continued revolution of the hand-wheel 2 will cause the take-up roll or drum 7 to revolve on the shaft 1 as desired.

The advantages of our take-up mechanism will be readily appreciated by those skilled in the art.

When any force is applied to rotate the take-up roll or drum 7 on the shaft 1 without the aid of the hand-wheel 2 by reason of the multiplying power of said hand-wheel and by reason of the eccentric portion 3 thereon, the

drum 7 will remain positively in any position given to it by the hand-wheel, so that there will be no backward or forward movement.

It will be understood that the details of construction of our take-up mechanism may be varied somewhat from what is shown and described.

We have described our take-up mechanism with special reference to its use as a take-up for the take-up roll or drum on a narrow-ware loom; but we do not limit ourselves to this application of our mechanism, as it may be used for any other purpose and may be adapted to be applied to different machines or mechanical structures.

Having thus described our invention, what we claim as new, and desire to secure by Letters Patent, is—

1. A take-up mechanism for looms, &c., comprising a metal shell to be secured on a shaft, the periphery of the shell having an opening therein for access to the bolt, which secures the hub of the shell on the shaft, and external gear-teeth on said hub, a drum or take-up roll mounted loosely on the periphery of said shell, and having internal gear-teeth on the edge thereof, a gear-rim extending loosely within said gear-teeth, and provided with external gear-teeth meshing therewith, and internal gear-teeth meshing with the teeth on the shell, and a hand-wheel having an eccentric hub or portion which extends within the central opening in the gear-rim, which opening is concentric with the gear-teeth on said rim, substantially as shown and described.

2. A take-up mechanism for looms, &c., comprising a metal shell to be secured on a shaft, and having external gear-teeth on its hub, a drum or take-up roll mounted loosely on the periphery of said shell, and having internal gear-teeth on the edge thereof, a gear-rim extending loosely within said gear-teeth, and provided with external gear-teeth meshing therewith, and internal gear-teeth meshing with the teeth on the shell, and a hand-wheel having an eccentric hub or portion which extends within the central opening in the gear-rim, which opening is concentric with the gear-teeth on said rim, substantially as shown and described.

GEORGE F. HUTCHINS.
WILLIAM D. THOMPSON.

Witnesses:

J. C. DEWEY,
M. J. GALVIN.