

Nov. 10, 1931.

F. A. GERLING

1,831,490

GUIDE MECHANISM FOR RECIPROCATORY ELEMENTS

Filed April 15, 1930

3 Sheets-Sheet 1

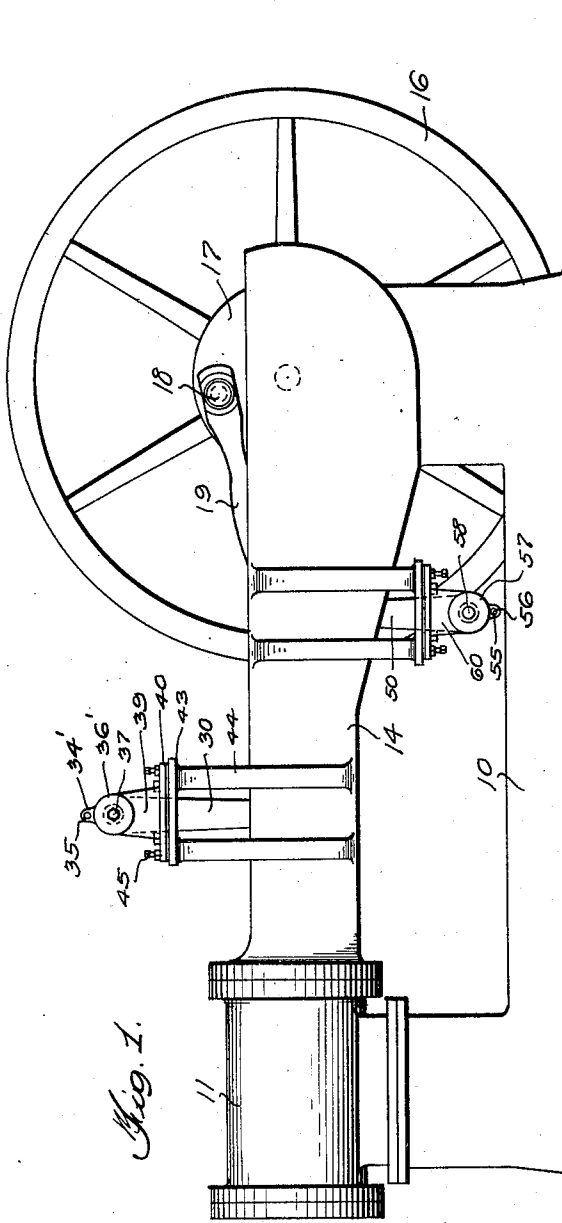

Fig. 1.

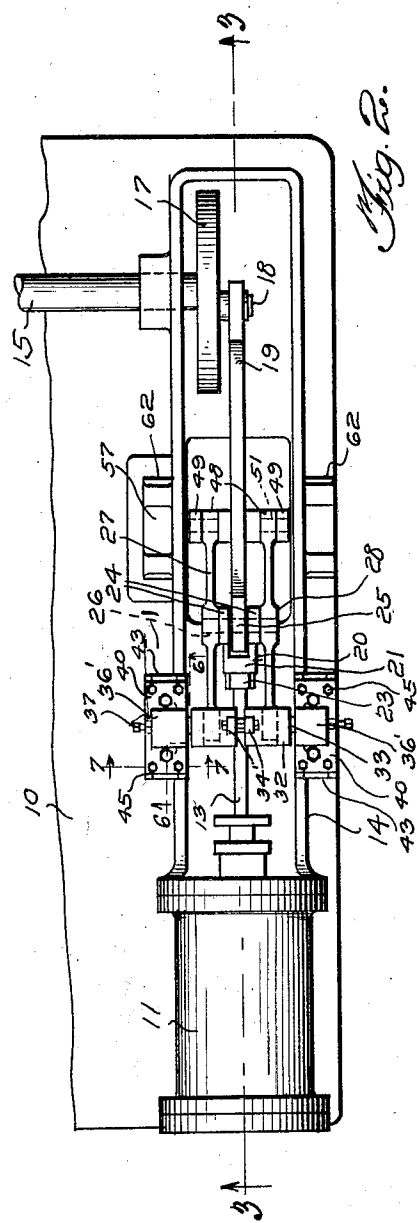

Fig. 2.

INVENTOR.
 FRED A. GERLING,
 BY *Jerry A. Matthews*

ATTORNEY.

Nov. 10, 1931.

F. A. GERLING

1,831,490

GUIDE MECHANISM FOR RECIPROCATORY ELEMENTS

Filed April 15, 1930

3 Sheets—Sheet 2

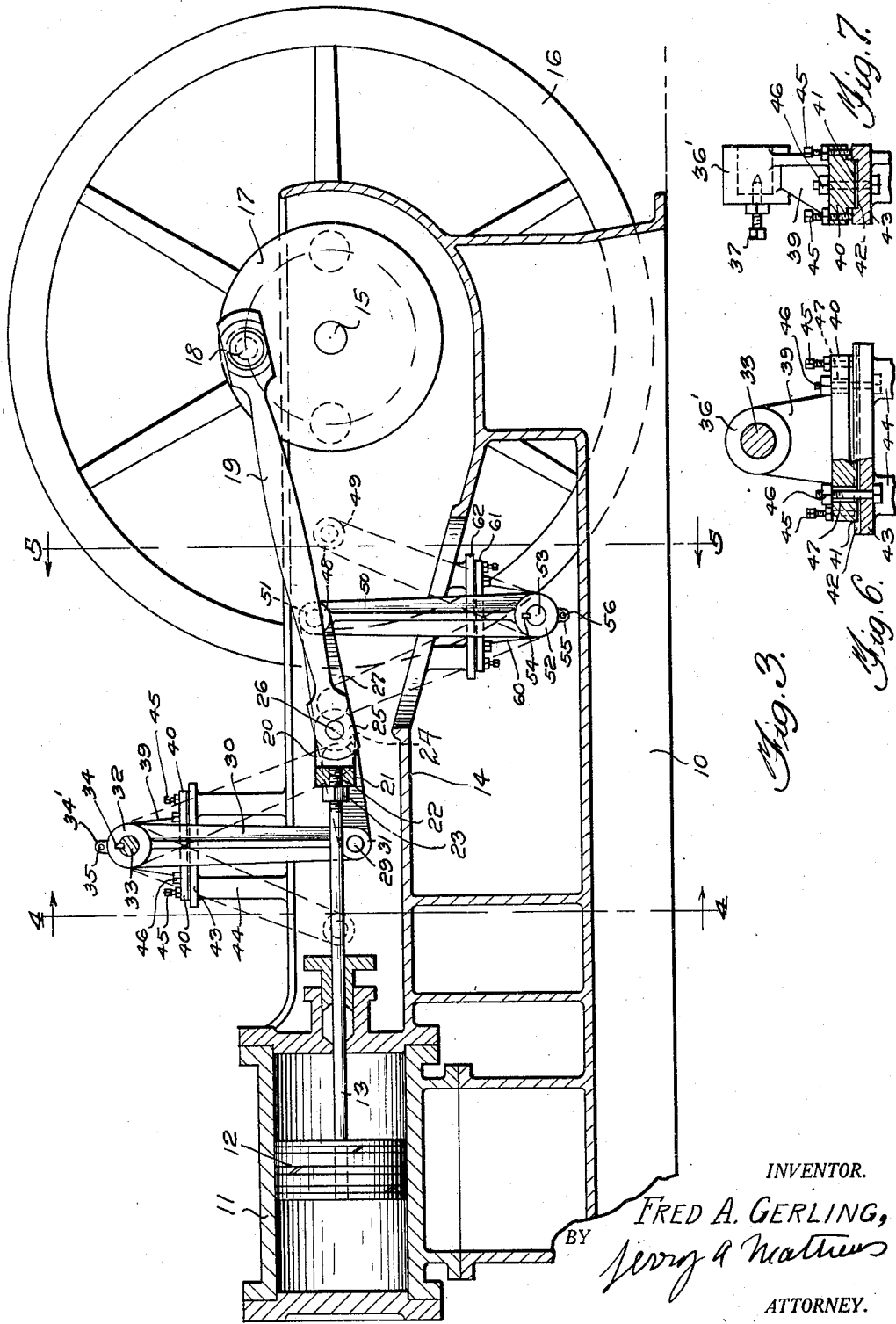

INVENTOR.

FRED A. GERLING,
BY Perry & Matthews

ATTORNEY.

Nov. 10, 1931.

F. A. GERLING

1,831,490

GUIDE MECHANISM FOR RECIPROCATORY ELEMENTS

Filed April 15, 1930

3 Sheets-Sheet 3

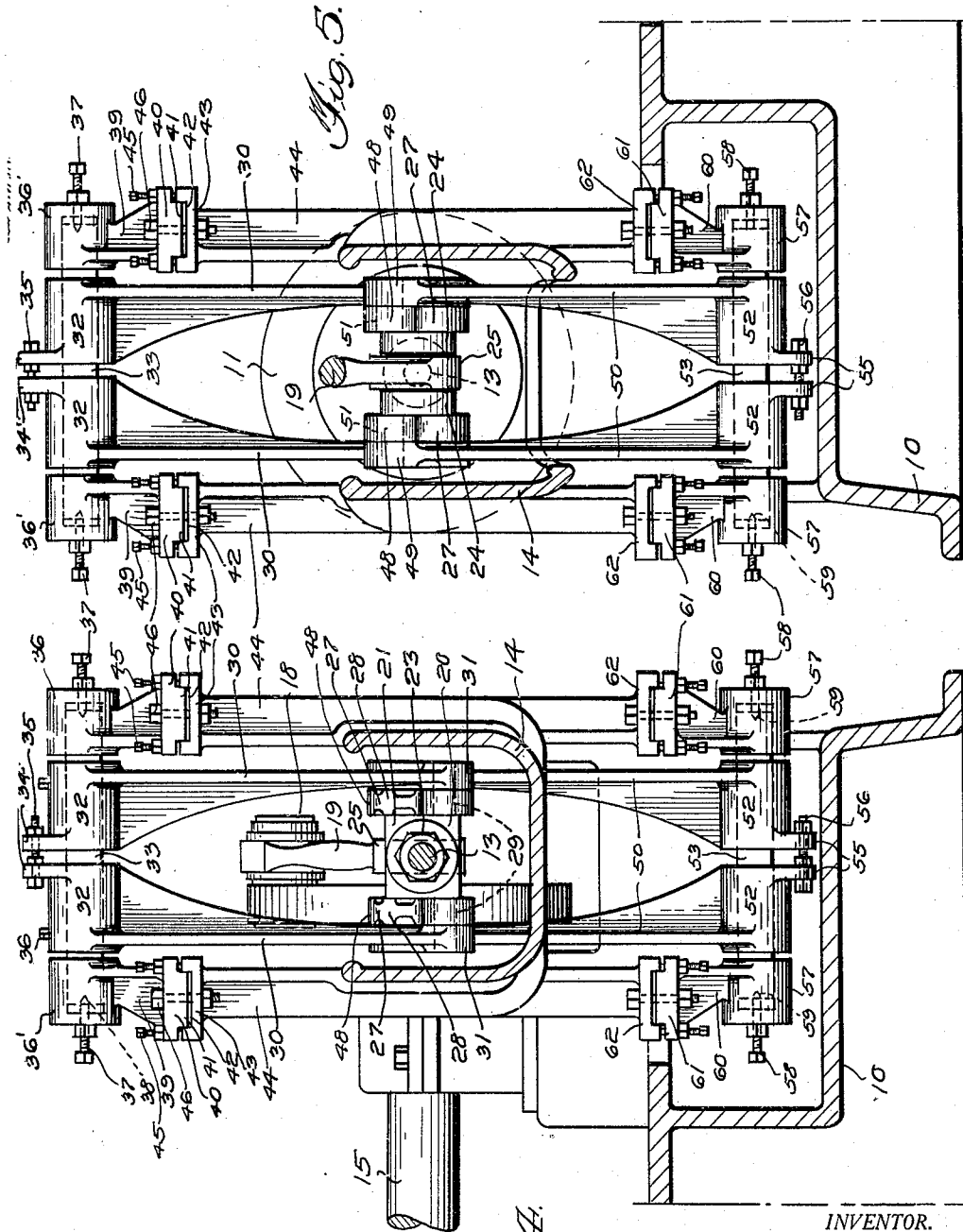

Fig. 5.

Fig. 4.

INVENTOR.

FRED A. GERLING,
BY *Wm. A. Matthews*

ATTORNEY.

UNITED STATES PATENT OFFICE

FRED A. GERLING, OF BOISE, IDAHO

GUIDE MECHANISM FOR RECIPROCATORY ELEMENTS

Application filed April 15, 1930. Serial No. 444,472.

My invention is a guide mechanism for a reciprocating element, such as the piston rod of an engine, pump, or the like.

An important object of the invention is to provide mechanism of the above mentioned character which will dispense with the employment of cross heads and gibbs, guides, guide rods, or the like.

A further object of the invention is to provide a mechanism of the above mentioned character which is adapted to maintain a reciprocatory element or rod in a straight line of motion, during its operation.

A further object of the invention is to provide mechanism of the above mentioned character which may be accurately adjusted for establishing and maintaining the straight line of motion of the reciprocatory element.

Other objects and advantages of the invention will be apparent during the course of the following description.

In the accompanying drawings, forming a part of this specification, and in which like numerals are employed to designate like parts throughout the same,

Figure 1 is a side elevation of an engine embodying my invention,

Figure 2 is a plan view of the same,

Figure 3 is a central vertical longitudinal section through the same,

Figure 4 is a transverse section taken on line 4-4 of Figure 3,

Figure 5 is a similar view taken on line 5-5 of Figure 3,

Figure 6 is an enlarged longitudinal section taken on line 6-6 of Figure 2, and,

Figure 7 is a transverse section taken on line 7-7 of Figure 2.

In the drawings, wherein for the purpose of illustration is shown a preferred embodiment of my invention, the numeral 10 designates a base of an engine, such as a steam engine, embodying a horizontally arranged cylinder 11, containing a piston 12, connected with a reciprocatory element or piston rod 13. Connected with the cylinder 11 is the usual crank case 14. The numeral 15 designates the crank shaft of the engine, driving the pulley 16 and carrying a crank disc 17 which rotates the same. This crank

disc has a wrist-pin 18, pivotally connected with a connecting rod 19.

The means for connecting the reciprocatory element 13 or piston rod with the connecting rod 19, and to guide the piston rod in its movement will now be described.

The numeral 20 designates a forked coupling, having a base 21, provided with a screw-threaded opening 22, receiving the screw-threaded end of the piston rod 13, and these parts are locked together by a jam nut 23. The forked coupling 20 is provided at its ends with a pair of apertured knuckles 24, receiving therebetween an apertured knuckle 25, formed upon the connecting rod 19. These knuckles are pivotally connected by a transverse pin 26. Arranged upon opposite sides of the knuckles 24 are supporting and guiding levers 27, provided centrally thereof with apertured bosses 28, pivotally receiving the ends of the transverse pin 26. The bosses 28 are arranged to contact with the knuckles 24, as shown. The left ends of the levers 27 are pivotally connected, as shown at 29, with depending links 30, having apertured bosses 31 at their lower ends. At their upper ends, these links 30 are provided with laterally and inwardly projecting sleeves 32, which are mounted upon a transverse horizontal shaft 33. The sleeves are keyed or feathered to the shaft 33 by means of a key 34, so that they may be adjusted longitudinally upon the shaft, but the shaft turns with the sleeves. The sleeves 32 carry radial lugs 34' adapted to be drawn together by an adjusting bolt 35, as shown. By drawing the sleeves 32 together, the links 30 are drawn together, and the bosses 31 are drawn into engagement with the ends of the levers 27, pressing them inwardly so that their bosses 28 press against the apertured knuckles 24. The sleeves 32 are also clamped to the shaft 33 by set screws 36. The ends of the shaft 33 are journaled within bearings 36', and the longitudinal adjustment of the shaft 33 is effected and maintained by means of bolts 37, having tapered ends, extending into recesses 38. The bearings 36 are carried by arms 39, rigidly mounted upon bases 40. These bases have depending tongues 41,

entering grooves 42, formed in brackets 43, the brackets being supported by vertical standards 44. The bases 40 are provided at their opposite ends with set screws 45, adapted to contact with the upper surfaces of the brackets 43, but having no screw-threaded engagement therewith. By manipulation of the set screws 45, the bases may be accurately angularly adjusted longitudinally and transversely. These bases are connected with the brackets 43 by means of bolts 46, passing through openings in the brackets and elongated slots 47 in the bases. The bases 40 may also be slightly longitudinally adjustable. The opposite or right ends of the levers 27 are provided with apertured knuckles 48, disposed inwardly of and in contact with apertured knuckles 49, formed upon upstanding pivoted links 50, and these apertured knuckles are pivotally connected by pins 51. The links 50 are provided at their lower ends with sleeves 52, mounted upon a transverse shaft 53, and keyed or feathered to the shaft, as shown at 54. The sleeves 52 are longitudinally adjustable upon the shaft 53, and the shaft turns with the sleeve and the sleeves have apertured lugs 55, adapted to be drawn together by an adjusting bolt 56. By drawing the sleeves 52 together, links 50 are drawn together and knuckles 49 engage knuckles 48, thereby forcing levers 27 together so that their bosses 28 engage the knuckles 24. The shaft 53 is journaled in bearings 57, and the shaft may be longitudinally adjusted by set screws 58 having pointed ends, engaging within recesses 59. The bearings 57 are carried by standards 60, secured to bases 61, attached to stationary brackets 62. Means are provided to adjustably clamp the bases 61 to the brackets 62, and the elements 61 and 62 are identical with the elements 40 and 43, except that they are inverted, and the adjustable connecting means is identical with that shown in connection with bases 40 and brackets 43, and it is, therefore, thought to be unnecessary to again describe the same in detail, it being sufficient to state that the bases 61 may be angularly adjusted, within limits, longitudinally and transversely, and also slightly longitudinally adjusted, and clamped to the brackets 62 in the selected adjusted position or positions.

The operation of the mechanism is as follows:

With the piston 10 in the intermediate position, Figure 3, it will be seen that the links 30 and 50 are vertical, and these links are of the same length, so that they describe arcs of circles having the same or equal radii. As the piston 10 moves forwardly, links 50, swing to the right and lower the right ends of the levers 27, and links 30 swing to the right raising the right end of these levers, for a distance equal to the lowering of their

right ends. The links 30 and 50 thus turn the levers 27 upon their central pivot 26, and positively support the central pivot through the medium of the levers 27, thus causing the piston rod or reciprocatory element 13 to travel in a straight line. As the piston 10 travels to the left, links 30 and 50 are first returned to the vertical position and they are swung to the left past this position, and they swing levers 27 in an opposite direction, said levers serving to positively support and guide the reciprocatory element, to cause the same to travel in a straight path. It is thus seen that the levers and links constitute a floating support for the reciprocatory element and guide the element both vertically and horizontally, causing the same to travel in a straight path throughout its entire movement in either direction. The proper adjustment of the links 30 and 50, for co-action with the levers 27, so that the levers in turn will properly guide the reciprocatory element, is effected by adjusting the bases 40 and 61, as explained.

It is to be understood that the form of my invention, herewith shown and described, is to be taken as a preferred example of the same, and that various changes in the shape, size and arrangement of parts, may be resorted to, without departing from the spirit of my invention, or the scope of the subjoined claims.

Having thus described my invention, I claim:—

1. In guide mechanism of the character described, a reciprocatory element, a pair of levers disposed upon opposite sides of the reciprocatory element and pivoted between their ends with the reciprocatory element, a pair of depending pivoted links engaging the outer sides of the levers and pivotally connected with corresponding ends of the levers, a pair of upstanding pivoted links engaging the outer sides of the levers and pivotally connected with the opposite corresponding ends of the levers, means to draw the links in each pair laterally together, said links co-acting with the levers to draw the levers together and to guide the reciprocatory element vertically and horizontally.

2. In guide mechanism of the character described, a reciprocatory element, a pair of levers engaging the opposite sides of the reciprocatory element and pivoted at their centers to the reciprocatory element by a common pivot, a transverse shaft supported upon one side of the levers near the corresponding ends of the same, a pair of links having sleeves longitudinally adjustably mounted upon the transverse shaft and engaging the outer sides of the links, means to draw the sleeves together, means to pivotally connect the opposite ends of the links with the adjacent ends of the levers, a transverse shaft supported upon the opposite side of the le-

vers near their corresponding opposite ends, a pair of links having sleeves longitudinally adjustably mounted upon the second named transverse shaft and engaging the outer sides of the links, means to draw the second named sleeves together, and means to pivotally connect the opposite ends of the second named links with the adjacent opposite ends of the levers, the arrangement being such that the links and levers co-act to draw the levers together and positively guide the reciprocatory element in a horizontal and vertical direction.

3. In guide mechanism of the character described, a reciprocatory element, a pair of levers disposed upon opposite sides of the element and pivoted at their centers to the reciprocatory element by a common pivot, a transverse shaft supported upon one side of the levers near corresponding ends of the same, a pair of links mounted upon the transverse shaft and having their opposite ends engaging the outer sides of the adjacent ends of the levers and pivotally connected therewith, a transverse shaft supported upon the other side of the levers near their corresponding opposite ends, a pair of links mounted upon the second transverse shaft and having their opposite ends engaging the outer sides of the adjacent ends of the levers and pivotally connected therewith, the arrangement of the levers and links being such that they co-act to guide the reciprocatory element in all directions so that it travels in a straight path.

4. In guide mechanism of the character described, a reciprocatory element, a pair of levers disposed upon opposite sides of the element and pivoted at their centers to the reciprocatory element by a common pivot, a transverse shaft supported upon one side of the levers near corresponding ends of the same, a pair of links mounted upon the transverse shaft and having their opposite ends engaging the outer sides the adjacent ends of the levers and pivotally connected therewith, a transverse shaft supported upon the other side of the levers near their corresponding opposite ends, a pair of links mounted upon the second named transverse shaft and having their opposite ends engaging the outer sides of the adjacent ends of the levers and pivotally connected therewith, the arrangement of the levers and links being such that they co-act to guide the reciprocatory element in all directions so that it travels in a straight path, and adjustable means for supporting the first and second named shafts.

In testimony whereof I affix my signature.

FRED A. GERLING.