

J. N. DAVIS.
SEAT FOR WATER CLOSET.

No. 49,731.

Patented Sept. 5, 1865.

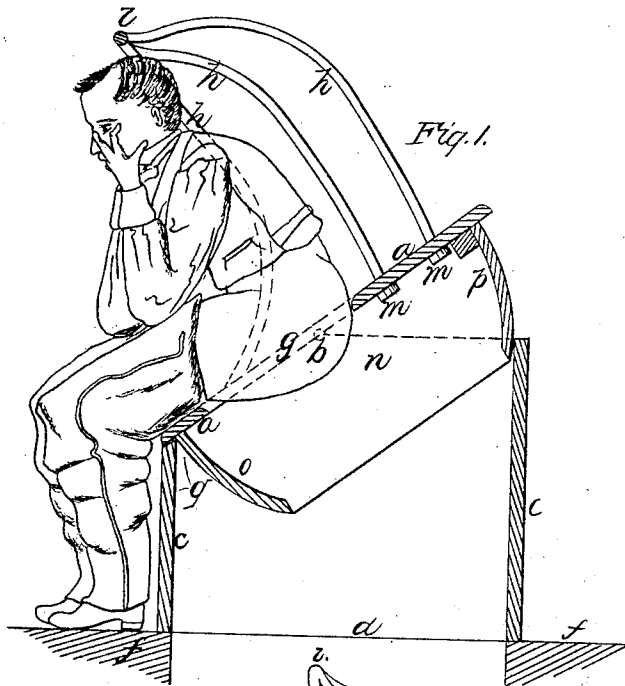

Fig. 1.

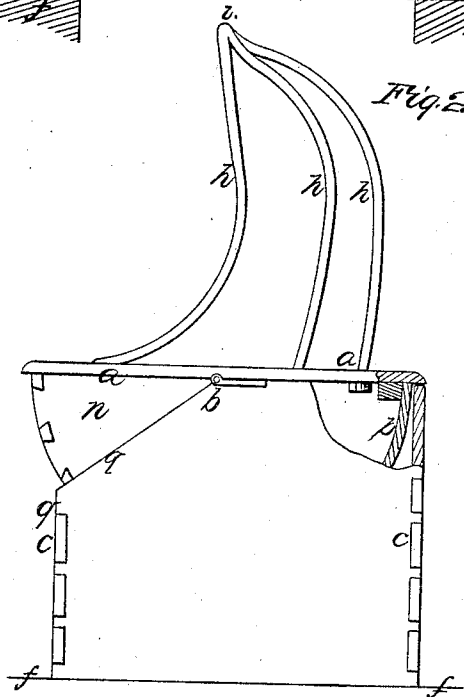

Fig. 2.

Witnesses:
Geo. Tinsley
Wm. Brown

Inventor:
J. N. Davis
By Munn & Co.

UNITED STATES PATENT OFFICE.

J. N. DAVIS, OF GEORGETOWN, OHIO.

SEAT FOR WATER-CLOSETS.

Specification forming part of Letters Patent No. 49,731, dated September 5, 1865.

To all whom it may concern:

Be it known that I, J. N. DAVIS, of Georgetown, Brown county, State of Ohio, have invented a new and useful Improvement in Arrangement of Seats for Water-Closets; and I do hereby declare that the following is a full, clear, and exact description thereof, which will enable others skilled in the art to make and use the same, reference being had to the accompanying drawings, forming part of this specification, in which—

Figure 1 is a central vertical section of the seat when in use; Fig. 2, a side view of the same when not in use.

Similar letters of reference indicate like parts.

The present invention consists in hanging the seat of a water-closet or other similar closet used by persons in the evacuation of their bowels upon a fulcrum or center, together with the use of any suitable protecting-frame attached to the upper surface of the seat and extending around, or nearly so, the rear half of the usual opening provided therein, whereby the seat can only be used in the right and proper manner, thus rendering it impossible to be defaced by the excrement of the person, as now often occurs from the improper use thereof.

a a represent the seat hung at opposite sides by a fulcrum, *b*, in the box or frame *c* surrounding the opening *d* made in the floor and communicating with the vault in the usual manner. In seat *a*, and at the usual place thereof, is an opening, *g*, as in ordinary water-closet seats, communicating with the interior of the box *c*. Around the rear half of the opening *g*, and fastened to the seat upon the upper surface thereof, are a series of vertical bent rods, *h h*, &c., meeting at their upper ends at one common point, *l*, as seen in the drawings, said rods being secured at their lower ends and upon the under side of the seat by screw-nuts *m m*, &c. To the under side of seat is a box-

frame, *n*, placed and moving freely within the box *c*, the front and rear sides, *o* and *p*, of which are made in a curved shape, as represented, with the fulcrum of the seat as a center. Each end piece, *q*, of the box *c* is cut away at an angle extending from the fulcrum *b* down toward the floor, so as to allow the seat to be inclined or tipped downward, turning upon its fulcrum *b*.

In the use of the water-closet seat, arranged as above described, the seat tips sufficiently to adjust itself to the different heights of persons, and its improper use is not only prevented by the rear frame around the seat-opening, but also by the tilting movement of the seat, as, in case a person should attempt to stand with the feet upon the same, it immediately tips forward and throws him off, the advantages of which are evident.

In lieu of the rod-frame described any frame of proper shape may be used which will accomplish the purpose of its use.

The sides of the inner box attached to the seat, as specified, should be of sufficient depth that when the seat is tipped to its lowest position, as seen in Fig. 1, no opening shall be exposed in the outer box whereby any of the effluvia arising from the vault could escape therefrom to the room.

The seat may be loaded upon its rear end, *r*, with any heavy metal or material, so as to cause it to resume its original position, or tip back, as the person arises therefrom.

I claim as new and desire to secure by Letters Patent—

A water-closet seat hung upon a fulcrum and having a suitable guard-frame attached to it, all substantially as and for the purposes specified.

J. N. DAVIS.

Witnesses:

SAMUEL FAGANS,
LEWIS A. SEARLES.