



Europäisches Patentamt  
European Patent Office  
Office européen des brevets



Publication number: **0 281 307 B1**

**EUROPEAN PATENT SPECIFICATION**

- (45) Date of publication of patent specification: **20.04.94** (51) Int. Cl.<sup>5</sup>: **H04L 5/24, H04L 25/38**
- (21) Application number: **88301557.0**
- (22) Date of filing: **24.02.88**

**(54) Asynchronous interface and method for coupling data between a data module and a serial asynchronous peripheral.**

- (30) Priority: **02.03.87 US 20483**
- (43) Date of publication of application: **07.09.88 Bulletin 88/36**
- (45) Publication of the grant of the patent: **20.04.94 Bulletin 94/16**
- (84) Designated Contracting States: **DE ES FR GB IT NL SE**
- (56) References cited: **FR-A- 2 314 623**

**PATENT ABSTRACTS OF JAPAN, vol. 11, no. 204 (E-520), 2nd July 1987 & JP-A-62 029 238**

**PATENT ABSTRACTS OF JAPAN, vol. 6, no. 195 (P-146), 5th October 1982 & JP-A-57 103 546**

- (73) Proprietor: **AMERICAN TELEPHONE AND TELEGRAPH COMPANY**  
**550 Madison Avenue**  
**New York, NY 10022(US)**
- (72) Inventor: **Lese, Gregory**  
**45 Darien Rd.**

**Howell New Jersey 07731(US)**  
**Inventor: Price, John Davis**  
**8 Village Lane**  
**Colts Neck New Jersey 07722(US)**  
**Inventor: Richardson, Ralph Eric**  
**93 Garrison Drive**  
**Tinton Falls New Jersey 07724(US)**  
**Inventor: Than, Cu Trong**  
**1744 Peachtree Circle**  
**Whitehall Pennsylvania 18052(US)**  
**Inventor: Vancura, Mark Douglas**  
**1725 Van Buren Circle**  
**Whitehall Pennsylvania 18052(US)**

- (74) Representative: **Buckley, Christopher Simon Thirsk et al**  
**AT&T (UK) LTD.,**  
**AT&T Intellectual Property Division,**  
**5 Mornington Road**  
**Woodford Green, Essex IG8 0TU (GB)**

**EP 0 281 307 B1**

Note: Within nine months from the publication of the mention of the grant of the European patent, any person may give notice to the European Patent Office of opposition to the European patent granted. Notice of opposition shall be filed in a written reasoned statement. It shall not be deemed to have been filed until the opposition fee has been paid (Art. 99(1) European patent convention).

## Description

This invention relates to asynchronous interfaces for and methods of coupling data between a data module and a serial asynchronous peripheral.

With the advent of large databases allowing information retrieval services, there has been a proliferation of various terminals, and computers configurable as terminals, in both businesses and homes for use with these databases.

Communication with a database is usually obtained through use of a data module which connects a terminal to the database through the telephone switched network. Data communications between the data module and the terminal may be in either of the well known bit synchronous or character asynchronous formats.

When a terminal operating in the asynchronous format is connected to a data module, selc' ... is the data going between the devices initially at the same speed. Rather, switches must often be manipulated on both devices in some systems to achieve the proper data speed match.

One approach in some systems has been to provide speed matching in the data module wherein the data module adapts to the speed of the connected terminal. Generally in this arrangement, the speed matching is accomplished by having a processor in the data module scan the received data lead very rapidly. This allows the processor to determine the speed of the character being transmitted by the terminal and match the speed of the data module thereto. Unfortunately, many other activities must be performed by the processor during the speed matching period of a data telephone employed in an Integrated Service Digital Network (ISDN) or a Digital Communications Protocol (DCP). In systems employing these protocols, the processor is therefore not normally available to do this sampling of data in order to determine the data transmission rate.

Another approach known in the art is to use the synchronous mode of a universal synchronous asynchronous receiver transmitter (USART) to match the speed of data from the terminal. The terminal receiver is placed in a bit synchronous receive mode by an associated processor using a specific predetermined control character. After determining the speed, the USART is placed back into the asynchronous mode to recover further characters. While the speed of transmission can be detected, this approach cannot reliably receive the first character, or may have problems receiving a second character if it arrives at a high speed with no additional delay. This approach also requires the use of a USART which is costly and therefore less acceptable where low cost in a system is desirable.

FR-A-2314623 discloses an automatic terminal data rate selection system which synchronizes receiver circuits to one of several speeds of data transmission. A receiving terminal in the system automatically responds to the rate of data transmission through the reception of a flag character which automatically sets the speed of the terminal to receive the following data transmission at the proper speed. The flag character is in every data message and precedes that data message in order for the system to adjust properly. In operation, the terminal senses the flag character, the rate at which it is being transmitted, and latches to set the speed of the terminal in synchronization with the transmission.

JP-A-6229238 discloses a transmitter-receiver for start-stop synchronous serial data. A sampling control circuit is included in the transmitter-receiver circuit for providing output baud rate clock pulses. Included in the sampling control circuit are a detector, a counter and a frequency divider. The detector receives sampling clock pulses and the received signal data provided to the sampling control circuit. The counter counts the number of sampling pulses in the width of a start bit in the signal data in order to discriminate the baud rate. The counter apparently counts the number of sampling pulses in the width of each subsequent bit for continuously discriminating the baud rate. The frequency divider divides the sampling clock pulses and outputs the desired baud rate clock pulses. The transmitter-receiver thus receives the data while automatically discriminating the baud rate of the received data through use of the sampling control circuit.

According to one aspect of this invention there is provided an asynchronous interface as claimed in claim 1.

According to another aspect of this invention there is provided a method of coupling data as claimed in claim 7.

In an embodiment of the invention the asynchronous interface determines the speed of data being transmitted by the terminal and received by the data module by measuring the period of the start bit in the first received character, adjusting to this data speed and receiving the remainder of the bits in this and subsequent characters at the new speed. For proper operation, the first data bit in the first received character from the terminal must be a logic ONE which is provided, for example, by a carriage return.

In determining the data rate, involvement of a processor associated with the data module is minimal. The processor is involved initially to request that the asynchronous interface determine the incoming data rate and match to this rate. After the rate has been determined and matched by the asynchronous interface, the processor is involved

once again to process the recovered character and new data rate. While the asynchronous interface determines and matches to the incoming data rate, the processor is freed for other tasks.

In operation, the asynchronous interface measures the speed of the start bit, and therefore the data rate, by converting a baud rate counter from its normal count down mode into a data speed determining mode. During normal operation when the speed of data being received by the data module is known, the baud rate counter reduces the count of a high speed clock to 16 times the known baud rate and uses this count to sample the middle of each bit in each character of the received data. When the speed of data being transmitted by the terminal and received by the data module must be determined, the baud rate counter is initialized at a predetermined count such as zero and activated at the beginning of the start bit of the first character. When a logic level one-to-zero transition occurs, which represents the leading edge of the start bit, the baud rate counter begins counting pulses from the high speed clock and continues to increment until a logic level zero-to-one transition occurs, which represents the end of the start bit and the beginning of the first data bit. At this point, the counter is inhibited and its count, which reflects the baud rate, is loaded into the status register, thereby allowing the processor to read the new baud rate. The baud rate counter is then returned to its normal count down mode to generate the 16 times clock of the just determined data speed. The remaining bits in the initial character, as well as those in subsequent characters, are all recovered at this new rate.

The invention will now be described with reference to the accompanying drawings, in which:

FIG. 1 is a block representation of the major functional components of the asynchronous interface embodying the invention;

FIG. 2 shows a schematic diagram of a baud rate generator suitable for use in FIG. 1;

FIG. 3 shows a block diagram of a transmitter section of the asynchronous interface of FIG. 1; and

FIG. 4 shows a block diagram of a receiver section of the asynchronous interface of FIG. 1.

Throughout the drawings, the same elements when shown in more than one figure are designated by the same reference numerals.

Referring now to FIG. 1,

there is shown a functional block representation of an asynchronous interface for providing a communication link between a data module (not shown) and a serial asynchronous peripheral 136 such as a data telephone. Included in the data module is a processor 130 which interacts with and is connected to the asynchronous interface. Pro-

cessor 130 may be one of many processors such as the 8088 microprocessor available from Intel Corporation.

Operation of this asynchronous interface is, in part, similar to that of a classical universal asynchronous receiver transmitter (UART). UARTs are well known in the art and are described by John E. McNamara in "Technical Aspects of Data Communication," (Digital Equipment Corporation, 1977).

As shown, the asynchronous interface comprises transmit and receive control registers 120, a control interface 110, an interrupt control 115, status registers 111, a processor interface 125 and a baud rate generator 200. Also included in the asynchronous interface are a transmit shift register 310 and a receive shift register 410 and also a transmit first-in-first-out (FIFO) data register 330 and a receive FIFO data register 430. With control information from the processor 130, the microprocessor interface 125 controls the reading and writing of the status registers 111, control registers 120, transmit FIFO data register 330 and receive FIFO data register 430. The status registers 111 read the status of control interface 110 which interfaces with the asynchronous peripheral 136 over a clear to send (CTS) output line 103 and a request to send (RTS) input line 102.

The interrupt control 115 provides changes in transmit, receive, or speed matching status via interrupt control line 101 directly to the processor 130. This interrupt control 115 may also inform the processor 130 when the control interface 110 has a lead state change on lines 102.

Data from the data module is coupled from the processor 130 via the processor interface 125 and transmit FIFO data register 330 to the transmit shift register 310. The transmit shift register 310 provides data to the asynchronous peripheral 136 on transmit data (TXD) line 301. Data from the asynchronous peripheral 136 is received by the receive shift register 410 over the receive data (RXD) line 401. The receive data is then coupled to the processor 130 and therefore the data module via the receive FIFO data register 430 and the microprocessor interface 125.

In order to determine the amount of data that maybe read by the processor 130 from the receive FIFO data register 430 or maybe written into the transmit FIFO data register 330, the status registers 111 monitor the amount of data stored in each of these registers and provide this information to the processor 130. A common clock 135 provides timing information for the processor 130 and also for the asynchronous interface via the baud rate generator 200 over line 209.

Referring now to FIG. 2, there is shown circuitry suitable for use in the arrangement of FIG 1 as the baud rate generator 200. This circuitry com-

prises a baud rate data register 201, an 11-bit counter 202, a baud rate control circuit 203, a prescaler 204 and a selector switch 205. The baud rate generator circuitry has two modes of operation, a normal operating mode in which a clock signal 16 times the baud rate is generated and a speed matching mode wherein the rate of transmission of data in a serial input stream from the asynchronous peripheral is determined.

During normal operation, the processor 130 shown in FIG. 1 controls the baud rate directly by writing an 11 bit rate determining count to the baud rate data register 201 over line 210 setting the baud rate. For this operating state, the processor 130 also writes via status registers 111 a normal operation on/off control bit on line 207 to the ON state. This control bit is received by the baud rate control circuit 203 which, in turn, resets the 11 bit counter 202 upon reaching a given count and also causes the selector switch 205 to couple the master clock input on line 209 directly to the 11 bit counter 202. The 11 bit counter 202 in this mode of operation is allowed to count up to the predetermined 11 bit count provided by the processor 130 and stored in the baud rate data register 201. Each time this count is reached, a clock strobe that is 16 times the predetermined received data rate is provided at line 206 from the control circuit 203. This clock strobe is used to sample the received data in the receive shift register 410, FIG. 4, and also used to clock out the data for transmission in the transmit shift register 310, FIG. 3, as will be explained in greater detail later herein. Each time the count is reached, the control circuit 203 resets the 11 bit counter 202 and the cycle is repeated.

When speed matching is desired, the processor 130 writes the on/off control bit on line 207 to the OFF state. This causes the control circuit 203 to preset the 11 bit counter 202 to a predetermined count and insert the prescaler 204 in the clock input path of the 11 bit counter via selector switch 205. Speed matching status is also provided to the processor 130 over the speed matching status line 208. The prescaler 204 reduces the clock input to the 11-bit counter 202 by 16 so that the correct baud rate is loaded into the baud rate data register 201. The on/off control bit on line 207 when in the OFF state also inhibits the control circuit 203 from resetting the 11-bit counter 202 as during normal operation.

Speed matching of the incoming data is achieved by the baud rate generator circuitry measuring the duration of the start bit of a serial input stream of data. For proper operation, the least significant bit, that is, the first received data bit, in the first received character must be a logical ONE. This is provided by a number of characters including a carriage return.

With input from the start bit detect circuit 411 in the receiver section shown in FIG. 4 and described later herein, the duration of the start bit is determined. The start bit detect circuit 411 looks for the beginning and end of the start bit. When a logic one-to-zero transition occurs, which represent the leading edge of the start bit, the start bit detect circuit 411 provides a signal indication to the baud rate control circuit 203 over line 212. And when a logic zero-to-one transition takes place, which represents the trailing edge of the start bit, a signal representing this transition is also provided to the baud rate control circuit 203 over this same line 212.

When the beginning of the start bit signal is provided to the baud rate control circuit 203, this circuit enables the 11 bit counter 202 which begins to count at the clock rate provided by the prescaler 204. The counter 202 continues to count until the end of the start bit signal is received by the control circuit 203 which then inhibits the counter 202. The count captured in the 11 bit counter 202 is then loaded into the baud rate data register 201 and the new baud rate read by the processor 130 over line 210. The baud rate control circuit 203 then places the 11-bit counter 202 into the normal counting mode to generate the 16 times clock of the just determined data rate, and the remaining bits in the initial character, as well as subsequent characters in the data stream, are recovered at this new rate. Data rates between 300 bits per second and 19.2 K bits per second are easily matched with this baud rate generator circuitry.

If too much data is entered in the counter 202 during speed matching, the counter will overflow and provide an overflow signal on line 211 to the processor 130 reflecting this error condition. This signal is provided to the processor 130 via the interrupt control 115 shown in FIG. 1.

Shown in FIG. 3 is a functional block diagram of the transmitter section of the synchronous interface. Data for transmission from the data module to the asynchronous peripheral 136 is coupled from the processor 130 via the microprocessor interface 125, both shown in FIG. 1, to the transmit data register 336 where it is stored. From this data register, the data is coupled to a steering logic circuit 335 which writes the data in bytes to each of multiple empty transmit registers 331 through 333. These transmit registers 331 through 334 comprise the transmit FIFO data register 330 shown in FIG. 1. The order for writing this data is to write to the least significant one of the multiple transmit registers that is empty. Then write to the second least significant transmit register and so forth.

Transmit interrupt control 116 is part of the interrupt control 115 shown in FIG. 1 and provides the transmit interrupt signal from the asynchronous

peripheral to the processor 130 over line 101. This control 116 also provides a status line 112 for enabling the processor 130 to monitor the number of empty transmit registers and thereby write more than one byte of data at a time.

A transmit interrupt status control signal from the control registers 120 in FIG. 1 is coupled over line 121 to the transmit interrupt control 116 to control the transmit registers 331 through 334. Data written to a more significant transmit register ripples down to the next most significant transmit register until it reached the least significant transmit register. By way of example, data written to the transmit register 334 will ripple down through registers 333 and 332 to the transmit register 331 where it is coupled to the transmit shift register 310. Also responsive to the control registers 120 is the parity generator 313. With input from the control registers 120 over line 124, this generator generates the proper parity and loads it into the most significant bit of the 8-bit transmit shift register 310.

The clock and control circuit 312 clocks the data from the transmit shift register 310 via the stop/start bit generator 311 to the serial transmit data output line 301. A general enable signal for controlling the transmit data from the clock and control circuit 304 is provided by the processor 130 over line 304 as transmit enable (TXEN). The 16 times baud rate clock signal on line 206 to the clock and control circuit 312 is from the baud rate generator 200 and controls the frequency or baud rate of the transmit data that is provided out to an asynchronous peripheral on line 301. And an output from a request to send/clear to send mode control circuit 113 on line 303 provides a mode control signal to the clock and control circuit 312 for regulating the clocking out of the transmit data.

Under the control of the clock and control circuit 312, the stop/start bit generator 311 generates a start bit at the beginning of a data byte and also generates a stop bit at the end of the data byte. One or two stop bits are selectable. Break generation is achieved via the break generator 122 which forces the TXD line 301 to a logic zero level for at least 10 consecutive bit periods. This break generation signal is controlled by control registers 120 shown in FIG. 1.

The mode control circuit 113 is part of the control interface 110 of FIG.1 and interfaces with the asynchronous peripheral over the RTS line 102 and CTS line 103. The mode of this control circuit is controlled by a status bit provided by control registers 120 over line 104. When the asynchronous interface is connected to an asynchronous peripheral operating in the data terminal equipment (DTE) mode, the control mode circuit 113 uses the CTS output line 103 as an indication to the asynchronous peripheral that there is data to be trans-

mitted on the TXD output line 301. When the asynchronous peripheral is able to accept this serial data on line 301, it provides a logical zero level on the RTS input line 102. This data in the transmit shift register 310 is then shifted out via the stop/start bit generator 311 to the output line 301.

Referring now to FIG. 4, there is shown a functional block diagram of the receiver section of the synchronous interface. Data from the asynchronous peripheral is received over line 401 by the asynchronous interface and is coupled into the receiver section via a start bit detector 411 and a voting circuit 412. The start bit detector 411 provides information about the duration of the start bit to the baud rate generator 200 as discussed earlier herein. The start bit detector also provides information about the start bit to a clock and control circuit 415. This clock and control circuit 415, in turn, provides three clock strobes to the voting circuit 412 for sampling the received input data. Such sampling is incorporated to increase the noise immunity of the receiver section. With the three clock strobes, the voting circuit 412 samples each receive data bit three times in the middle of the bit period. For example, if two zero logic levels and a one logic level are measured, a logic zero is coupled from the voting circuit 412 as the selected input to the receive shift register 410. Input timing for the clock and control 415 is provided by the 16 times baud rate clock signal on line 406 from the baud rate generator 200.

After the data has been properly shifted and loaded into the receive shift register 410, it is transferred in bytes to the multiple receive registers 431 through 436, beginning with the least significant receive register 431. These registers comprise the receive FIFO data register 430 shown in FIG. 1. The data is cycled through receive registers 432, 433, 434, 435 and 436, and then coupled on to the steering logic 437. This steering logic 437 fetches the most significant data byte from the receive registers and connects it to a receive data register 438. This register is read by the processor 130 via line 123 which connects the receive data register 438 to the processor interface block 125. Load control 422 controls the loading of the data from the receive shift register 410 and clocks it into the multiple receive registers 431 through 436. This load control 422 is connected to the break detect bit 431 to disable loading whenever a break signal is detected. The load control is also connected to a start/stop frame detect 414 which examines the receive data for frame error conditions and produces an error bit signal if a framing error should occur.

A receive enable circuit 420 is used as a master receive enable control and controls when data is loaded from the receive shift register 410 to

the multiple receive registers 431 through 436. Providing input to the receive enable circuit is a request to send/clear to send mode control circuit 114. The mode control circuit 114 is part of the control interface 110 of FIG.1 and interfaces with the asynchronous peripheral over the RTS line 102 and CTS line 103. This mode control 114 also provides a control input to the receive enable circuit 420.

When the DCE mode is selected, the RTS signal on line 102 is an input and connects an asynchronous peripheral to the asynchronous interface. When the asynchronous peripheral requests transmission of data to the asynchronous interface, it provides a logic zero level on the RTS input line 102. If the multiple receive registers 431-436 are not full, this indication being provided by the receive interrupt control 117 and if the receive section is enabled as reflected by an enable signal on line 403, then the CTS output line 103 from the control circuit 114 goes to a logical zero indicating to the asynchronous peripheral that transmission to the receiver section in the asynchronous interface may take place. The receive interrupt control 117 is a part of the interrupt control 115 shown in FIG. 1. If the multiple receive registers 431 through 436 are full of data, the CTS output line 103 will not be enabled until at least one register is available. The receive interrupt control 117 also indicates via line 101 to the processor 130 of a receive interrupt condition. This interrupt from the control registers 120 is provided to the interrupt control 117 via the receive interrupt control line 405. A status bits line 407 is connected to the status register 111 and is used for providing to this register status information regarding the receiver section.

Certain other control signals are generated in the asynchronous interface to improve processing of the data. A status signal on line 406 provides information to status registers 111 as to how many receive characters are in the receive registers 432 through 436 so that multiple reads can be made by the processor 130 to save time during polling. If interrupts are enabled, then the interrupt control 117 indicates to the processor 130 via line 101 which particular receive interrupt condition has occurred. A break bit detect 421 on line 404 indicates to the processor 130 that a break has been detected. A parity check 423 compares the parity received versus the parity selected in control registers 120. This information is used along with an overrun or frame error detect condition from the start/stop frame detect 414 as an error bit and follows the receive data word through receive registers 431 through 436. The parity information is also provided over line 409 to the status registers 111 where it is read as required.

If the receiver is enabled and the DCE mode has not been selected in control circuit 114, a receive FIFO overrun condition could possibly occur if seven or more data bytes are received before the processor 130 has read one of them. If this condition does occur, an indication as to such will be provided over control line 408 to status registers 111. In addition, the number of data bytes then in the multiple receive registers 431 through 436 will be provided from the receive interrupt control 117 via line 407 and the status registers 111 to the processor 130.

Modifications of this asynchronous interface are possible and may obviously be implemented by those skilled in the art. Thus the invention may be practised otherwise than as specifically described.

### Claims

1. An asynchronous interface for coupling data between a data module and a serial asynchronous peripheral, the asynchronous interface being configurable in response to control signals from the data module and comprising control means (203) responsive to the control signals from the data module, means (200,410 and 430) for receiving a serial asynchronous data stream from the serial asynchronous peripheral, means (200) for determining a rate of data reception of the serial asynchronous data stream being transmitted by the serial asynchronous peripheral to the asynchronous interface, and CHARACTERIZED BY the receiving means comprising counting means (202) arranged to operate in a first configuration for providing a clock source for sampling and determining the one or zero state of each bit in the data being received by the asynchronous interface, and the determining means comprising the counting means reconfigured by the control means and arranged to operate in a second configuration for measuring the duration of the period of the start bit in a first received character, the counting means incrementing up to and providing a count reflective of the period of the start bit, and rate conversion means (201, 204 and 205) responsive to both the control means and the counting means for realigning the data stream receiving means for receiving data at a rate reflective of the period of the start bit in the first received character.
2. An interface as claimed in claim 1 wherein the counting means arranged to operate in the first configuration comprises a start bit detector (411) for sensing the beginning of the start bit

period.

3. An interface as claimed in claim 1 wherein the counting means reconfigured by the control means and arranged to operate in the second configuration comprises a start bit detector (411) configured for sensing the beginning and ending of the start bit period. 5
4. An interface as claimed in claim 3 wherein the counting means reconfigured by the control means and arranged to operate in the second configuration comprises a prescaler (204) arranged for providing a reduced frequency clock source so that the count provided by the counting means is directly reflective of the period of the start bit. 10
5. An interface as claimed in claim 4 wherein the serial asynchronous data stream is arranged so that the first data bit in the first received character occurs in the one state. 15
6. An interface as claimed in claim 1 comprising means (125) for interfacing with external processing means, the processing means serving to provide the control signals to the control means for reconfiguring the control means whenever the rate of data reception from the asynchronous peripheral is to be determined, and the rate conversion means serving to provide status signals to the processing means reflecting the rate of data reception from the asynchronous peripheral. 20
7. A method of coupling data between a data module and a serial asynchronous peripheral, the data from the asynchronous peripheral being provided to an asynchronous interface configurable in response to control signals from the data module, the method comprising the steps of: 25
- providing a controller responsive to the control signals from the data module,
- receiving a serial asynchronous data stream from the serial asynchronous peripheral, 30
- determining a rate of data reception of the serial asynchronous data stream being transmitted by the serial asynchronous peripheral to the asynchronous interface, and
- CHARACTERIZED BY**
- the receiving step comprising operating a counter in a first configuration for providing a clock source for sampling and determining the one or zero state of each bit in the data being received by the asynchronous interface, and the determining step comprising operating the

counter reconfigured by the controller and operating in a second configuration for measuring the duration of the period of the start bit in a first received character, the counter incrementing up to and providing a count reflective of the period of the start bit, and

realigning the counter so that it is configured for operating in the first configuration for providing a clock source for sampling and for receiving data at a rate reflective of the period of the start bit in the first received character.

8. A method as claimed in claim 7 wherein the counter operating in the first configuration comprises a start bit detector for sensing the beginning of the start bit period. 15
9. A method as claimed in claim 7 wherein the counter reconfigured by the controller and operating in the second configuration comprises a start bit detector configured for sensing the beginning and ending of the start bit period. 20
10. A method as claimed in claim 9 wherein the counter reconfigured by the controller and operating in the second configuration comprises a prescaler arranged for providing a reduced frequency clock source so that the count provided by the counting means is directly reflective of the period of the start bit. 25
11. A method as claimed in claim 10 comprising the step of arranging the serial asynchronous data stream so that the first data bit in the first received character occurs in the one state. 30
12. A method as claimed in claim 7 comprising the step of interfacing with an external processor, the processor providing the control signals to the controller for reconfiguring the controller whenever the rate of data reception from the asynchronous peripheral is to be determined, and the realigning step providing status signals to the processor reflecting the rate of data reception from the asynchronous peripheral. 35

#### Patentansprüche

1. Asynchrone Schnittstelle zur Kopplung von Daten zwischen einem Datenmodul und einem seriellen, asynchronen Peripheriegerät, wobei die asynchrone Schnittstelle unter Ansprechen auf Steuersignale vom Datenmodul konfigurierbar ist und eine Steuereinrichtung (203) aufweist, die auf die Steuersignale vom Datenmodul anspricht, ferner eine Einrichtung (200, 410 und 430) zur Aufnahme eines seriellen, asynchronen Datenstroms von dem seriellen,

- asynchronen Peripheriegerät, und eine Einrichtung (200) zur Bestimmung einer Rate für den Empfang des seriellen, asynchronen Datenstroms, der von dem seriellen, asynchronen Peripheriegerät zu der asynchronen Schnittstelle übertragen wird, dadurch gekennzeichnet, daß die Empfangseinrichtung eine Zähleinrichtung (202) aufweist, die so ausgelegt ist, daß sie in einer ersten Konfiguration zur Bereitstellung einer Taktquelle zur Abtastung und Bestimmung des Eins- oder Null-Zustandes jedes Bit der durch die asynchrone Schnittstelle empfangenen Daten arbeitet, und daß die Bestimmungseinrichtung die Zähleinrichtung aufweist, die durch die Steuereinrichtung neu konfiguriert worden ist, so daß sie in einer zweiten Konfiguration zur Messung der Dauer des Startbit in einem ersten empfangenen Zeichen arbeitet und bis auf einen die Dauer des Startbit wiedergebenden Zählwert hochzählt und diesen bereitstellt, und daß die Bestimmungseinrichtung ferner eine Ratenumwandlungseinrichtung (201, 204 und 205) aufweist, die unter Ansprechen sowohl auf die Steuereinrichtung als auch die Zähleinrichtung die Datenstrom-Empfangseinrichtung derart neu ausrichtet, daß sie Daten mit einer Rate empfängt, die die Dauer des Startbit im ersten empfangenen Zeichen wiedergibt.
2. Schnittstelle nach Anspruch 1, bei der die Zähleinrichtung, die in der ersten Konfiguration arbeitet, einen Startbitdetektor (411) aufweist, der den Anfang der Startbitperiode feststellt.
  3. Schnittstelle nach Anspruch 1, bei der die Zähleinrichtung, die durch die Steuereinrichtung neu konfiguriert worden ist und in der zweiten Konfiguration arbeitet, einen Startbitdetektor (411) aufweist, der den Anfang und das Ende der Startbitperiode feststellt.
  4. Schnittstelle nach Anspruch 3, bei der die Zähleinrichtung, die durch die Steuereinrichtung neu konfiguriert worden ist und in der zweiten Konfiguration arbeitet, einen Vorteiler (204) umfaßt, der eine verringerte Taktquellenfrequenz liefert, so daß der von der Zähleinrichtung gelieferte Zählwert direkt die Dauer des Startbit wiedergibt.
  5. Schnittstelle nach Anspruch 4, bei der der serielle, asynchrone Datenstrom so beschaffen ist, daß das erste Datenbit im ersten empfangenen Zeichen in dem einen Binärzustand auftritt.
  6. Schnittstelle nach Anspruch 1, mit einer Einrichtung (125) zur Schnittstellenbildung mit einer externen Verarbeitungseinrichtung, die die Steuersignale an die Steuereinrichtung zu deren Neukonfiguration immer dann liefert, wenn die Rate des Datenempfangs vom asynchronen Peripheriegerät zu bestimmen ist, wobei die Ratenumwandlungseinrichtung Zustandssignale an die Verarbeitungseinrichtung liefert, die die Rate des Datenempfangs vom asynchronen Peripheriegerät wiedergeben.
  7. Verfahren zur Kopplung von Daten zwischen einem Datenmodul und einem seriellen, asynchronen Peripheriegerät, wobei die Daten vom asynchronen Peripheriegerät an eine asynchrone Schnittstelle geliefert werden, die unter Ansprechen auf Steuersignale vom Datenmodul konfigurierbar ist, mit den Verfahrensschritten:
    - Bereitstellen eines Steuergerätes, das auf die Steuersignale vom Datenmodul anspricht, Empfangen eines seriellen, asynchronen Datenstroms vom seriellen, asynchronen Peripheriegerät, Bestimmen einer Rate für den Datenempfang des seriellen, asynchronen Datenstroms, der vom seriellen, asynchronen Peripheriegerät zur asynchronen Schnittstelle übertragen wird, dadurch gekennzeichnet, daß der Empfangsschritt den Betrieb eines Zählers in einer ersten Konfiguration zur Bereitstellung einer Taktquelle für das Abtasten und Bestimmen des Eins- oder Null-Zustandes jedes Bit in den durch die asynchrone Schnittstelle empfangenen Daten umfaßt, daß der Bestimmungsschritt einen Betrieb des durch das Steuergerät neu konfigurierten und in einer zweiten Konfiguration arbeitenden Zählers zur Messung der Dauer des Startbit in einem ersten empfangenen Zeichen umfaßt, wobei der Zähler auf einen die Dauer des Startbit wiedergebenden Zählwert hochzählt und diesen bereitstellt, und daß der Zähler neu konfiguriert wird, so daß er in der ersten Konfiguration arbeitet und eine Taktquelle zur Abtastung und zum Empfang von Daten mit einer Rate bereitstellt, die die Dauer des Startbit im ersten empfangenen Zeichen wiedergibt.
    8. Verfahren nach Anspruch 7, bei dem der in der ersten Konfiguration betriebene Zähler einen Startbitdetektor aufweist,

der den Anfang der Startbitperiode feststellt.

9. Verfahren nach Anspruch 7, bei dem der durch das Steuergerät neu konfigurierte und in der zweiten Konfiguration betriebene Zähler einen Startbitdetektor aufweist, der den Anfang und das Ende der Startbitperiode feststellt.
10. Verfahren nach Anspruch 9, bei dem der durch das Steuergerät neu konfigurierte und in der zweiten Konfiguration betriebene Zähler einen Vorteiler aufweist, der eine verringerte Taktquellenfrequenz liefert, so daß der von der Zählleinrichtung bereitgestellte Zählwert die Dauer des Startbit direkt wiedergibt.
11. Verfahren nach Anspruch 10, bei dem der serielle asynchrone Datenstrom so ausgelegt ist, daß das erste Datenbit im ersten empfangenen Zeichen in dem einen Binärzustand auftritt.
12. Verfahren nach Anspruch 7, mit dem Schritt einer Schnittstellenbildung mit einem externen Prozessor, der die Steuersignale an das Steuergerät zur Neukonfiguration des Steuergerätes immer dann liefert, wenn die Rate des Datenempfangs vom asynchronen Peripheriegerät zu bestimmen ist, und daß der Neuausrichtungsschritt Zustandssignale für den Prozessor bereitstellt, die die Rate des Datenempfangs vom asynchronen Peripheriegerät wiedergeben.

#### Revendications

1. Interface asynchrone pour le couplage de données entre un module de données et un périphérique asynchrone série, cette interface asynchrone étant configurable en réponse à des signaux de commande provenant du module de données et comprenant un moyen de commande (203) répondant aux signaux de commande provenant du module de données, un moyen (200, 410 et 430) pour recevoir un train de données asynchrone série provenant du périphérique asynchrone série, un moyen (200) pour déterminer une vitesse de réception des données du train de données asynchrone série transmis par le périphérique asynchrone série à l'interface asynchrone, et CARACTERISÉ PAR le moyen de réception comprenant un moyen de comptage (202) disposé pour fonctionner dans une première configuration pour fournir une source d'horloge pour échantillonner et déterminer l'état un ou zéro de

chaque bit dans les données reçues par l'interface asynchrone, et le moyen de détermination comprenant le moyen de comptage reconfiguré par le moyen de commande et disposé pour fonctionner dans une deuxième configuration pour mesurer la durée de la période du bit de départ dans un premier caractère reçu, le moyen de comptage incrémentant jusqu'à et fournissant un compte représentatif de la période du bit de départ, et un moyen de conversion de vitesse (201, 204 et 205) répondant à la fois au moyen de commande et au moyen de comptage pour réaligner le moyen de réception de train de données pour recevoir les données à une vitesse représentative de la période du bit de départ dans le premier caractère reçu.

2. Interface selon la revendication 1, dans laquelle le moyen de comptage disposé pour fonctionner dans la première configuration comprend un détecteur de bit de départ (411) pour détecter le début de la période du bit de départ.
3. Interface selon la revendication 1, dans laquelle le moyen de comptage reconfiguré par le moyen de commande et disposé pour fonctionner dans la deuxième configuration comprend un détecteur de bit de départ (411) configuré pour détecter le début et la fin de la période du bit de départ.
4. Interface selon la revendication 3, dans laquelle le moyen de comptage reconfiguré par le moyen de commande et disposé pour fonctionner dans la deuxième configuration comprend un diviseur préalable (204) disposé pour fournir une source d'horloge de fréquence réduite de manière à ce que le compte fourni par le moyen de comptage soit directement représentatif de la période du bit de départ.
5. Interface selon la revendication 4, dans laquelle le train de données asynchrone série est disposé de manière à ce que le premier bit utile dans le premier caractère reçu se produise avec l'état un.
6. Interface selon la revendication 1, comprenant un moyen (125) pour s'interfacer avec un moyen de traitement externe, le moyen de traitement servant à fournir les signaux de commande au moyen de commande pour reconfigurer le moyen de commande chaque fois que la vitesse de réception des données provenant du périphérique asynchrone est à déterminer, et le moyen de conversion de vitesse

servant à fournir au moyen de traitement les signaux d'état représentatifs de la vitesse de réception des données provenant du périphérique asynchrone.

7. Méthode de couplage de données entre un module de données et un périphérique asynchrone série, les données provenant du périphérique asynchrone étant fournies à une interface asynchrone configurable en réponse à des signaux de commande provenant du module de données, cette méthode comprenant les étapes de:

fourniture d'un contrôleur répondant aux signaux de commande provenant du module de données,

réception d'un train de données asynchrone série provenant du périphérique asynchrone série,

détermination d'une vitesse de réception des données du train de données asynchrone série transmis par le périphérique asynchrone série à l'interface asynchrone, et

#### CARACTERISEE PAR

l'étape de réception comprenant le fonctionnement d'un compteur dans une première configuration pour fournir une source d'horloge pour échantillonner et déterminer l'état un ou zéro de chaque bit dans les données reçues par l'interface asynchrone, et l'étape de détermination comprenant le fonctionnement du compteur reconfiguré par le contrôleur et fonctionnant dans une deuxième configuration pour mesurer la durée de la période du bit de départ dans un premier caractère reçu, le compteur incrémentant jusqu'à et fournissant un compte représentatif de la période du bit de départ, et

le réaligement du compteur de manière à ce qu'il soit configuré pour fonctionner dans la première configuration pour fournir une source d'horloge pour échantillonner et pour recevoir des données à une vitesse représentative de la période du bit de départ dans le premier caractère reçu.

8. Méthode selon la revendication 7, dans laquelle le compteur fonctionnant dans la première configuration comprend un détecteur de bit de départ pour détecter le début de la période du bit de départ.

9. Méthode selon la revendication 7, dans laquelle le compteur reconfiguré par le contrôleur et fonctionnant dans la deuxième configuration comprend un détecteur de bit de départ configuré pour détecter le début et la fin de la période du bit de départ.

10. Méthode selon la revendication 9, dans laquelle le compteur reconfiguré par le contrôleur et fonctionnant dans la deuxième configuration comprend un diviseur préalable disposé pour fournir une source d'horloge de fréquence réduite de manière à ce que le compte fourni par le moyen de comptage soit directement représentatif de la période du bit de départ.

11. Méthode selon la revendication 10, comprenant l'étape de disposition du train de données asynchrone série de manière à ce que le premier bit utile dans le premier caractère reçu se produise avec l'état un.

12. Méthode selon la revendication 7, comprenant l'étape d'interfaçage avec un processeur externe, le processeur fournissant les signaux de commande au contrôleur pour reconfigurer le contrôleur chaque fois que la vitesse de réception des données provenant du périphérique asynchrone est à déterminer, et l'étape de réaligement fournissant au processeur des signaux d'état représentatifs de la vitesse de réception des données provenant du périphérique asynchrone.

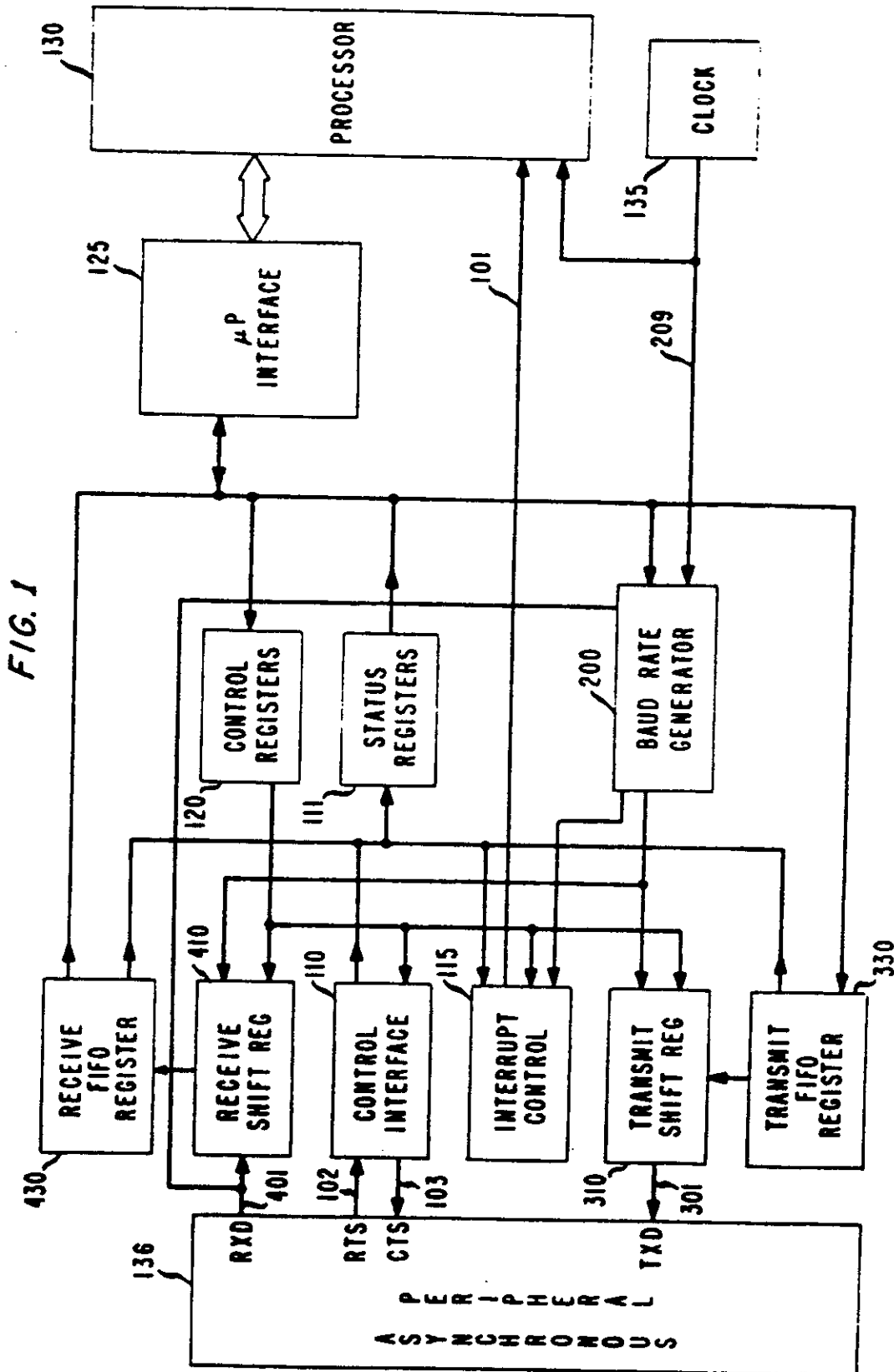

FIG. 2

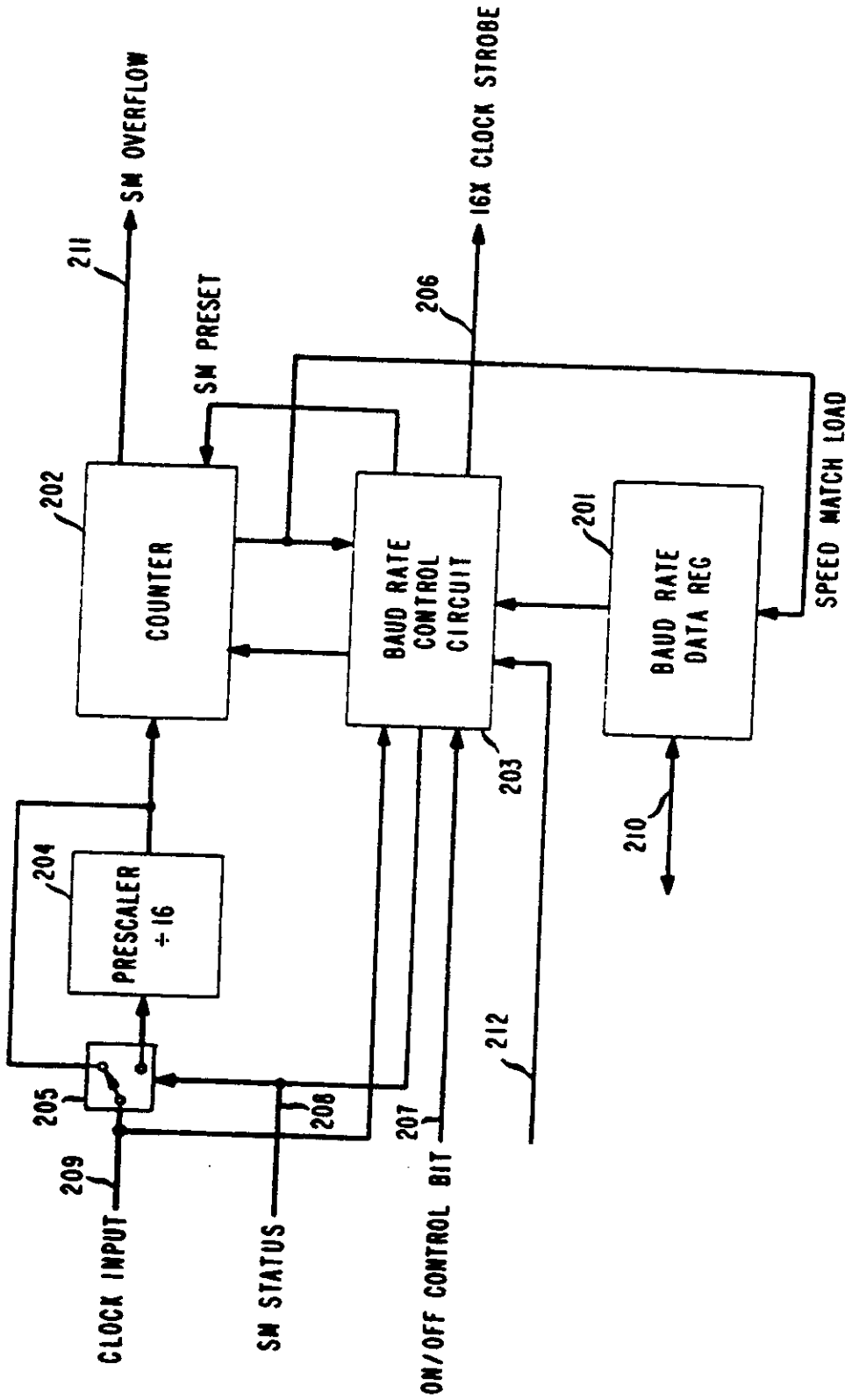
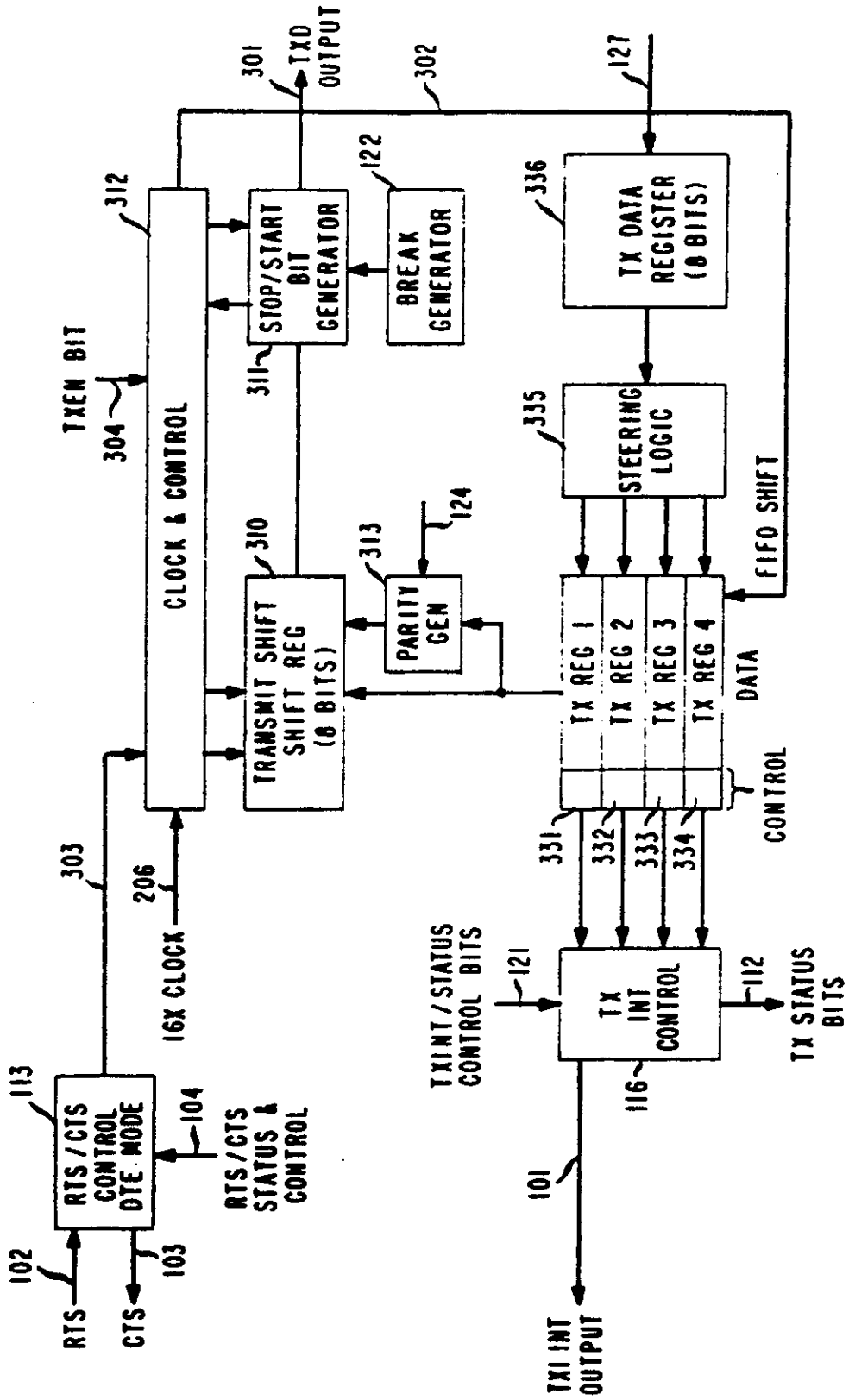
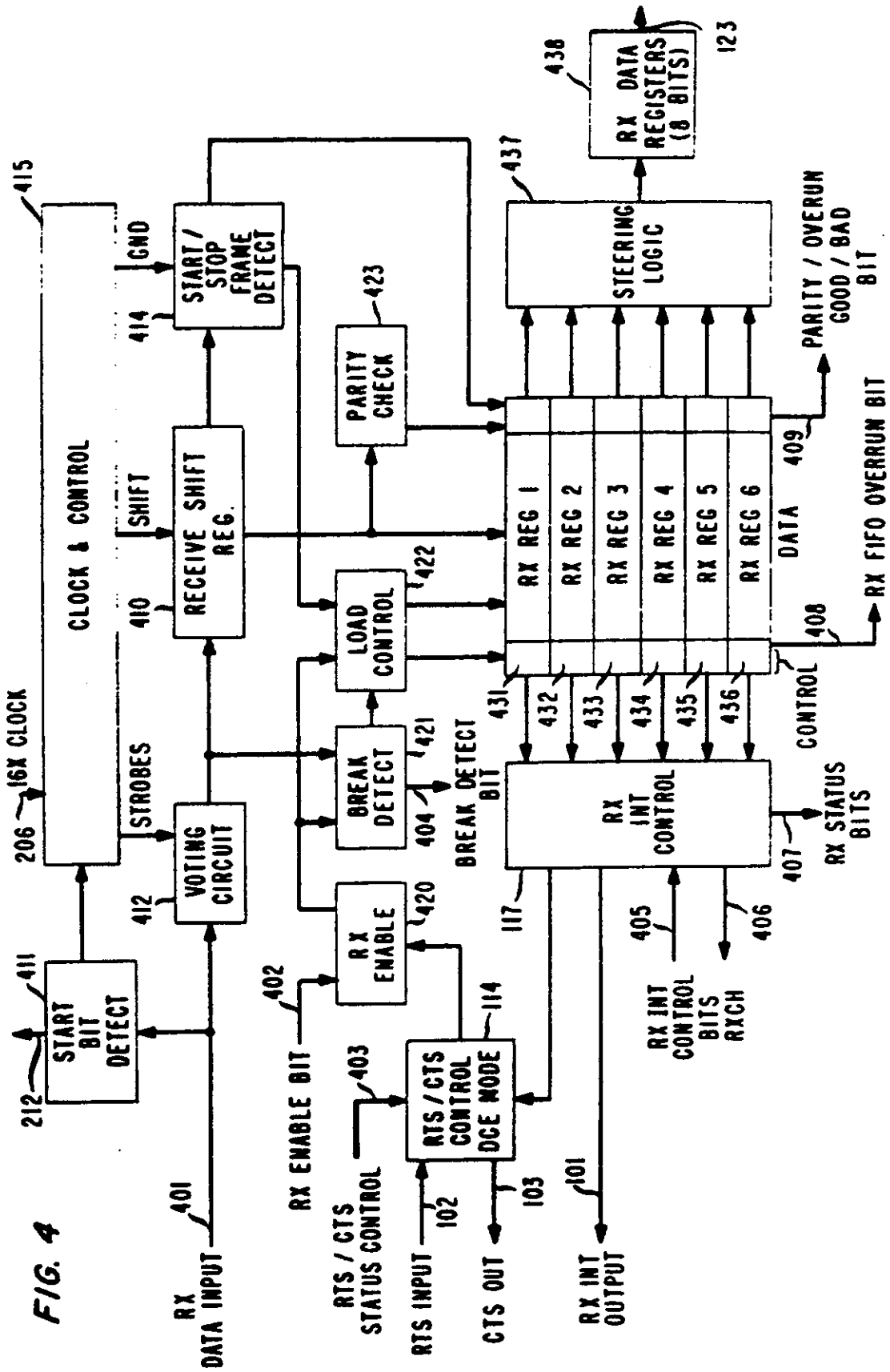

FIG. 3





REGISTER ENTRY FOR EP0281307

European Application No EP88301557.0 filing date 24.02.1988

Priority claimed:

02.03.1987 in United States of America - doc: 20483

Designated States DE ES FR GB IT NL SE

Title METHOD AND APPARATUS FOR DETECTING A RATE OF DATA TRANSMISSION

Applicant/Proprietor

AMERICAN TELEPHONE AND TELEGRAPH COMPANY, 550 Madison Avenue, New York, NY  
10022, United States of America [ADP No. 50209329002]

Inventors

GREGORY LESE, 45 Darien Rd., Howell New Jersey 07731, United States of  
America [ADP No. 55939664001]

JOHN DAVIS PRICE, 8 Village Lane, Colts Neck New Jersey 07722, United  
States of America [ADP No. 55939672001]

RALPH ERIC RICHARDSON, 93 Garrison Drive, Tinton Falls New Jersey 07724,  
United States of America [ADP No. 55939680001]

CU TRONG THAN, 1744 Peachtree Circle, Whitehall Pennsylvania 18052, United  
States of America [ADP No. 55939698001]

MARK DOUGLAS VANCURA, 1725 Van Buren Circle, Whitehall Pennsylvania 18052,  
United States of America [ADP No. 55939706001]

Classified to

H4P  
H04L

Address for Service

AT&T (UK) LTD, 5 Mornington Road, WOODFORD GREEN, Essex, IG8 0TU, United  
Kingdom [ADP No. 00053413001]

EPO Representative

CHRISTOPHER SIMON THIRSK BUCKLEY, AT&T (UK) LTD. AT&T Intellectual  
Property Division 5 Mornington Road, Woodford Green, Essex IG8 0TU, United  
Kingdom [ADP No. 50001775001]

Publication No EP0281307 dated 07.09.1988

Publication in English

Examination requested 12.12.1990

Patent Granted with effect from 20.04.1994 (Section 25(1)) with title  
ASYNCHRONOUS INTERFACE AND METHOD FOR COUPLING DATA BETWEEN A DATA MODULE  
AND A SERIAL ASYNCHRONOUS PERIPHERAL.

---

01.10.1990 EPO: Search report published on 31.10.1990

Entry Type 25.11 Staff ID.

Auth ID. EPT

- 18.03.1994 Notification from EPO of change of EPO Representative details from  
CHRISTOPHER SIMON THIRSK BUCKLEY, AT&T (UK) LTD. AT&T Intellectual  
Property Division 5 Mornington Road, Woodford Green, Essex IG8 OTU,  
United Kingdom [ADP No. 50001775001]  
to  
CHRISTOPHER SIMON THIRSK BUCKLEY, AT&T (UK) LTD., AT&T Intellectual  
Property Division, 5 Mornington Road, Woodford Green, Essex IG8  
OTU, United Kingdom [ADP No. 50001775001]  
Entry Type 25.14 Staff ID. RD06 Auth ID. EPT
- 29.06.1994 Application under Section 32 filed on 28.06.1994  
Entry Type 8.1 Staff ID. LM1 Auth ID. F20
- 13.07.1994 Notification of change of Applicant/Proprietor name and address of  
AMERICAN TELEPHONE AND TELEGRAPH COMPANY, 550 Madison Avenue, New  
York, NY 10022, United States of America [ADP No. 50209329002]  
to  
AT&T CORP., Incorporated in USA - New York, 32 Avenue Of The  
Americas, New York, New York 10013-2412, United States of America  
[ADP No. 06560486001]  
dated 20.04.1994. Official evidence filed on GB2262867  
Entry Type 7.1 Staff ID. NM Auth ID. F20

\*\*\*\* END OF REGISTER ENTRY \*\*\*\*

OA80-01  
AS

OPTICS - PATENTS

15/07/94 13:45:31  
PAGE: 1

RENEWAL DETAILS

PUBLICATION NUMBER EP0281307

PROPRIETOR(S)

AT&T Corp., Incorporated in USA - New York, 32 Avenue Of The  
Americas, New York, New York 10013-2412, United States of America

DATE FILED 24.02.1988

DATE GRANTED 20.04.1994

DATE NEXT RENEWAL DUE 24.02.1995

DATE NOT IN FORCE

DATE OF LAST RENEWAL

YEAR OF LAST RENEWAL 00

STATUS PATENT IN FORCE