

(No Model.)

2 Sheets—Sheet 1.

C. L. CARMAN.
STONE CRUSHER.

No. 525,402.

Patented Sept. 4, 1894.

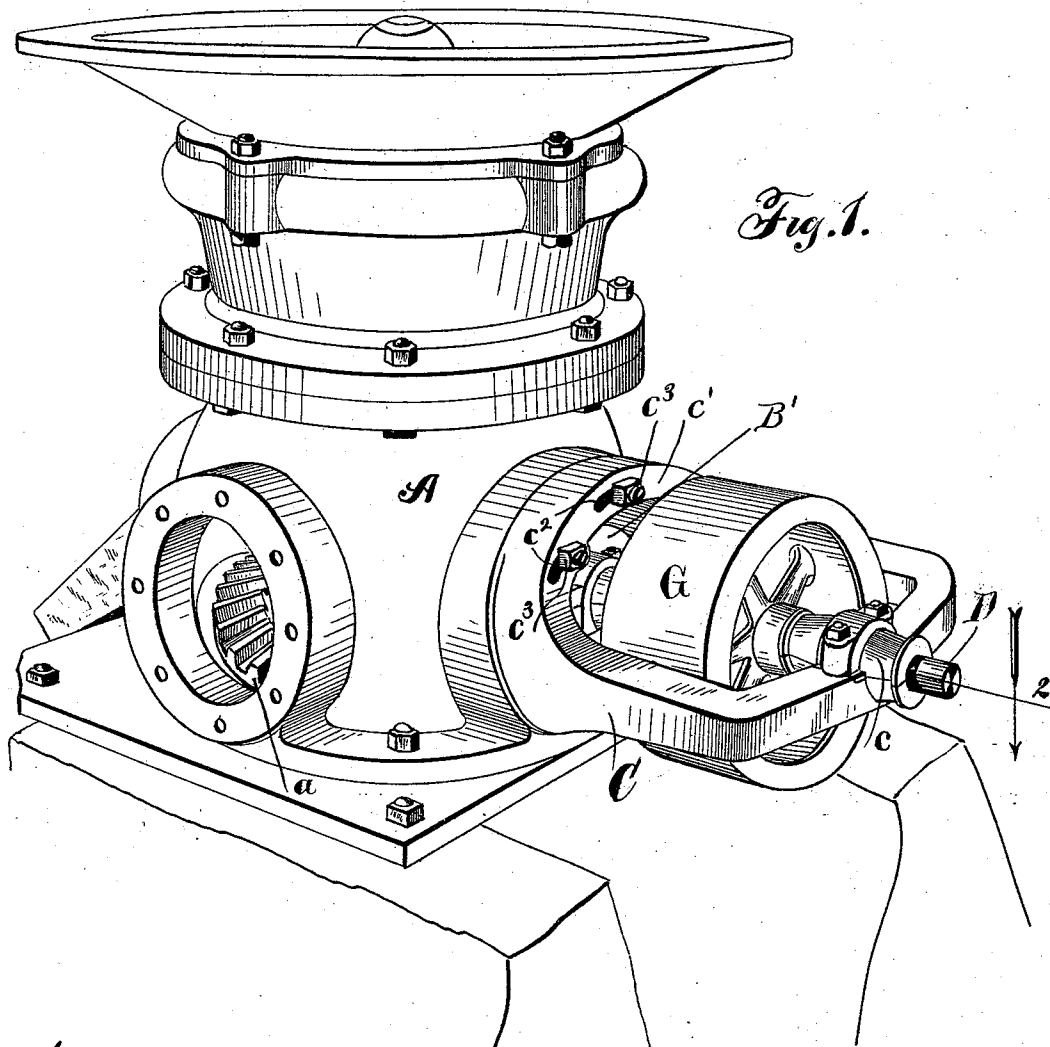

Witnesses:
Edw. Gaylord,
Lute S. Alter

Inventor:
Charles L. Carman,
By *Dunning & Dunning*
Attys

C. L. CARMAN.
STONE CRUSHER.

No. 525,402.

Patented Sept. 4, 1894.

Fig. 2.

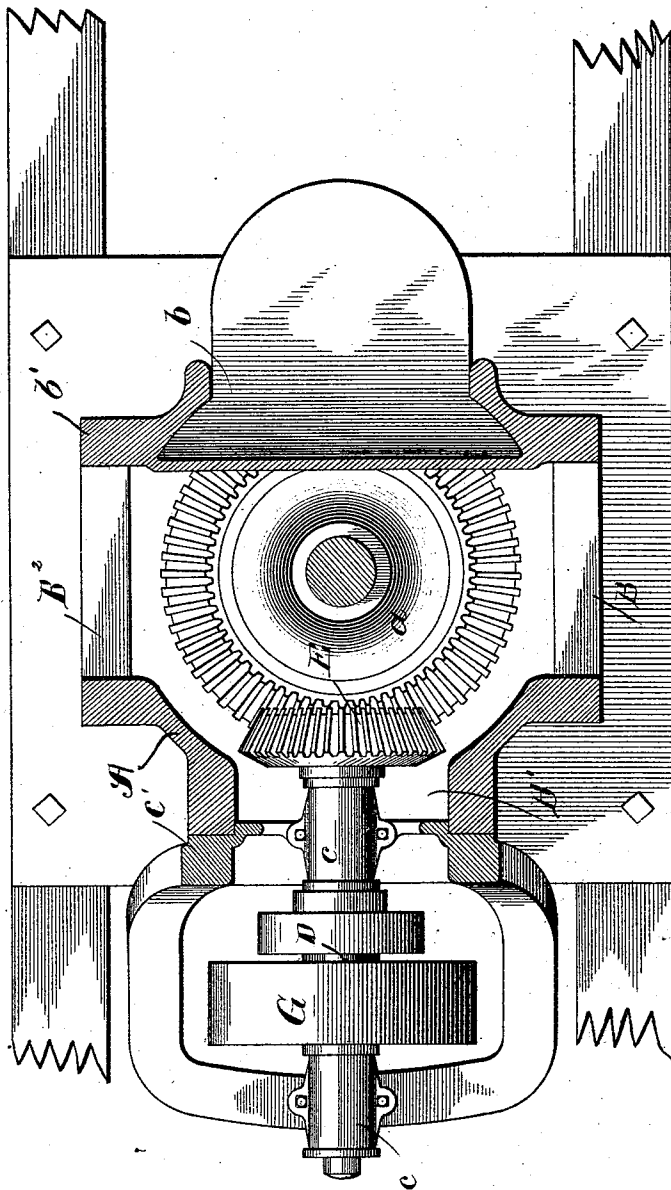

Witnesses:
Edw. J. Gaybird
Levi S. Alter

Inventor:
Charles L. Carman,
By Manning & Manning
Attys.

UNITED STATES PATENT OFFICE.

CHARLES L. CARMAN, OF CHICAGO, ILLINOIS, ASSIGNOR TO THE GATES
IRON WORKS, OF SAME PLACE.

STONE-CRUSHER.

SPECIFICATION forming part of Letters Patent No. 525,402, dated September 4, 1894.

Application filed October 24, 1893. Serial No. 489,006. (No model.)

To all whom it may concern:

Be it known that I, CHARLES L. CARMAN, a citizen of the United States, residing at Chicago, Illinois, have invented certain new and useful Improvements in Stone-Crushers, of which the following is a specification.

The object of my invention is to provide a simple, economical and efficient stone breaker, and it is intended to be an improvement upon the invention of A. J. Gates, for which Letters Patent were granted bearing date February 7, 1893, No. 491,096.

This invention relates particularly to the method of securing and adjusting the driving mechanism to the crusher frame; and it consists in the features, details and combinations hereinafter described and claimed.

In the drawings, Figure 1 is a perspective view showing my improvement attached to a stone crusher; and Fig. 2 a transverse horizontal section, taken on line 2 of Fig. 1, looking in the direction of the arrow.

In the use of stone breakers and crushers the opening for discharging the crushed material, which slides down upon an inclined diaphragm or chute from the crushing mechanism, is generally located at some fixed point to discharge the crushed material into a carrier which may transfer it to any desired point. The line shaft for driving the carrier is generally the shaft which is used to drive or operate the driving mechanism of the crusher. It is usual to secure this driving mechanism so that it will enter an opening in the rear of the crusher frame at a point opposite the discharge opening; but it is often desirable to have such driving mechanism, which actuates the crusher mechanism, enter an opening at right angles to the discharge opening at either side of the machine, so that the carrier mechanism may be operated directly from the line shaft, as well as the crusher driving mechanism, without the intervention of beveled gearing or a quarter turn of the driving belts.

In the Letters Patent above referred to, the mechanism for driving the crushing mechanism is secured to a rotatable base, in such manner that when it is necessary to change the driving mechanism from one opening to another, the entire machine has

to be disturbed, necessitating both loss of time and labor. My invention is intended to do away with these objections and to provide a self contained yoke or bracket for supporting the driving mechanism, adapted to be attached to the frame in line with openings directly opposite the discharge opening, or to enter either of the openings at right angles thereto, and have no outer support, so that when it is changed from one opening to another, it does not necessitate the disturbing of the crushing mechanism or shell. As no support beyond the bracket is necessary for the driving mechanism, it also does away with the necessity for a base for the machine, thereby saving considerable expense in the way of material and labor. It is also intended to provide means by which the supporting bracket of the driving mechanism may be adjusted to any desired angle to clear the belt used in operating the same.

In constructing my improved stone crusher, I use a crusher, A, preferably of the type known as the "gyrating crusher," provided with the usual gyrating shaft, which has the crushing mechanism of the well-known form at the top; but as this forms no particular portion of my invention, I deem it unnecessary to describe it here fully in detail. The gyrating shaft is supplied with the usual beveled gear, *a*, at its lower end, adapted to be operated by the driving mechanism. The lower portion of the crusher frame is provided, preferably, with three openings, B, B', and B², located preferably at equi-distant points around the circumference of the crusher, adjacent to the beveled gear on the gyrating shaft. Secured, preferably for the purposes of illustration, to the crusher and in line with the opening, B', directly opposite the discharge opening, *b*, is a self contained bracket, C, which is provided with bearings, *c*, in which is mounted a driving shaft, D, having its inner end provided with a beveled pinion, E, engaging with the beveled gear, *a*, of the gyrating shaft, in such manner that the rotating of the driving shaft is imparted through the beveled gears to operate the gyrating shaft. The driving shaft is supplied with an ordinary pulley, G, or this can be dispensed with and an ordinary spur gear used in its

place, which may be operated by a suitable train of gears, in order to multiply the power or speed used for the operating and crushing mechanism. The openings B, B' and B², in the crusher frame can be of any desired diameter, and are provided with projecting flanges, b', to which may be secured the supporting frame or bracket, in such manner that it may be adjusted at any desired angle to avoid contacting or rubbing of the belt which operates the driving pulley, or so that a spur gear may be engaged with the train of driving gears. To accomplish this, I provide the flanged portion, c', of the bracket with elongated slots or openings, c², and the crusher frame with screw studs and nuts, c³, so that the bracket after it is adjusted to the desired angle may be securely held in that position by the tightening of the nuts against the flanged portion of the bracket. This is one method by which this adjustment may be accomplished; but it is evident to the skilled mechanic that other methods might be used.

In the ordinary use of my improved stone crusher, the driving mechanism will be located and secured to the crusher frame at and in line with the opening, B', opposite the discharge opening, and the crusher so located as to discharge the broken or crushed material at the desired point. If, from any cause, it is necessary to locate the driving shaft with its attached mechanism at right angles to the discharge opening and secure it to the crusher in line with either of the openings, B or B², all that is necessary to do is to unscrew the nuts, c³, so as to allow the supporting frame or bracket to be removed from the studs, when it may be placed on a set of studs attached to the crusher frame around one of the flanged openings, and the nuts screwed up on these studs, so as to firmly clamp and hold the supporting frame with its driving mechanism in position.

From the foregoing description, it will be seen that it is not necessary to disturb the crushing mechanism or the crusher frame, and the changing of the operating or driving mechanism is accomplished economically and efficiently.

In using the word "self-contained" I mean a bracket which supports and carries in its bearings the entire intermediate, operating mechanism, in such manner that when an operation or series of operations removes this bracket, it removes all of the intermediate mechanism with it, leaving such mechanism in its operative state; or, in other words, all of the parts are left in their normal position with relation to each other and the supporting bracket.

I claim—

1. In stone breakers, the combination of a crusher frame provided with several openings located around its circumference, crushing mechanism located therein and having its operating gear arranged adjacent to such openings, a self-contained bracket having the intermediate driving mechanism rotatably mounted therein so as to remove or secure such mechanism to the crusher frame by the removal or securing of the bracket to the frame, and means for securing the bracket with its driving mechanism to the crusher frame at and in line with one or more of its openings to engage with and operate the crushing mechanism, substantially as described.

2. In stone breakers, the combination of a crusher frame provided with a discharge opening, an opening opposite and in line therewith and an opening or openings at right angles thereto, crushing mechanism located therein and having its driving gear adjacent to several of such openings, a bracket having the driving mechanism rotatably mounted therein and adapted to be secured to the crusher frame at and in line with any one of several of its openings, and means for adjustably securing the bracket to the crusher frame at and in line with such openings for the purpose of engaging its driving mechanism with the operating mechanism of the crusher, substantially as described.

CHARLES L. CARMAN.

Witnesses:

PHILETUS WARREN GATES,
JOHN J. BREWIS.