

Feb. 16, 1932.

A. I. ABRAHAMS
LOUD SPEAKER DIAPHRAGM

1,845,210

Filed March 20, 1929

Fig. 1.

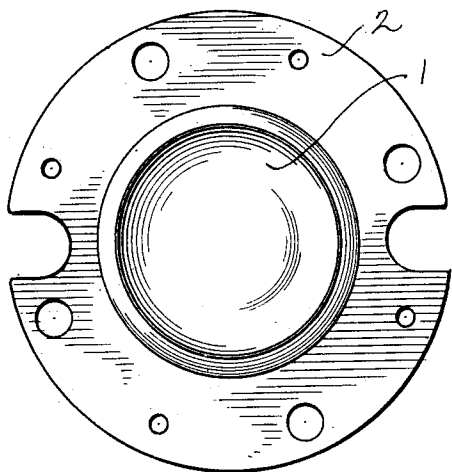

Fig. 2.

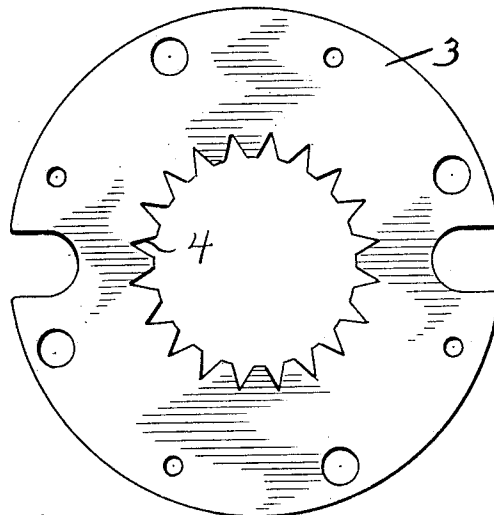

Fig. 3.

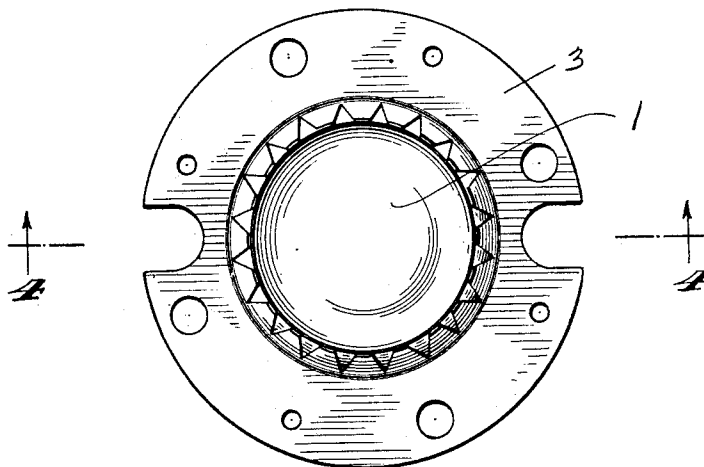

Fig. 4.



INVENTOR
Alexander I. Abrahams
BY *Mock & Blum*
ATTORNEYS

UNITED STATES PATENT OFFICE

ALEXANDER I. ABRAHAMS, OF NEW YORK, N. Y.

LOUD SPEAKER DIAPHRAGM

Application filed March 20, 1929. Serial No. 348,455.

My invention relates to a new and improved diaphragm for loud speaker units of the electro-dynamic horn type.

One of the objects of my invention is to provide an improved diaphragm made of very thin metal, to be used as part of an electro-magnetic driving unit for loud speakers, and in particular loud speakers of the horn type.

Another object of my invention is to provide a diaphragm forming part of the driving unit of a loud speaker or the like, made of very thin metal or other suitable light and fragile material which is so constructed at its edge so as to enable it to be clamped into position, without breakage.

Other objects of my invention will be set forth in the following description and drawings which illustrate a preferred embodiment thereof, it being understood that the above general statement of the objects of my invention is intended merely to generally explain the same and not to limit it in any manner.

Fig. 1 is a top view of the metallic part of the diaphragm.

Fig. 2 is a top view of the cloth part of the diaphragm.

Fig. 3 is a top view showing the metallic and cloth parts assembled.

Fig. 4 is a sectional view along the line 4-4 of Fig. 1.

In making driving units for loud speakers, especially loud speakers of the horn type, it has been customary to make the diaphragms of very thin light metal such as duralumin. This diaphragm is stamped from a sheet of duralumin about .002 of an inch thick.

Such diaphragms have been made in various shapes but they have been ordinarily provided with peripheral flanges by means of which the said diaphragms were clamped. These flanges frequently cracked because the thin metal flange yielded when the diaphragms were vigorously vibrated to produce a large volume of sound.

According to my invention, the metal diaphragm 1 is stamped out of thin metal to any desired shape. The diaphragm 1 is provided with a peripheral flange 2. The entire diaphragm can be stamped out of a single sheet

of thin duralumin about .002 of an inch thick.

The flange 2 is provided with a flexible member 3 which is preferably made of impregnated fabric such as strong linen impregnated with several coats of a nitro-cellulose lacquer. A fabric of this type is relatively inextensible and it is highly flexible and it can be readily connected to the diaphragm 1 by means of any suitable adhesive such as a celluloid cement.

As shown in Fig. 2, the flexible member 3 is provided with serrations 4 by means of which it can be connected to the inner inclined flange of the diaphragm 1, as shown in Fig. 3.

Since the entire surface of the cloth member 3 is secured by an adhesive to the corresponding part of the diaphragm 1, and in particular to the flange 2, the said flange either does not crack or else the cracks are prevented from spreading.

Even if a complete circumferential crack does form in the metal flange 2, the diaphragm is still supported by the cloth member 3.

While I prefer to use an impregnated cloth, I do not wish to be limited to this particular material because a suitable leather could be employed for example.

It is desirable to use a relatively inextensible non-metallic material such as the cloth above mentioned, for making the member 3. If the flange 2 cracks, and the light diaphragm 1 is supported partially or solely by the member 3, the natural period of vibration of the diaphragm 1 remains above the ordinary audible range because the member 3 is relatively inextensible although it has sufficient elasticity to permit the diaphragm 1 to vibrate. If the flange does not crack, or if minute cracks are formed therein, the natural period of vibration of the diaphragm is above the ordinary audible range, so that the diaphragm reproduces sound uniformly throughout the audible range.

I have shown a preferred embodiment of my invention, but it is clear that numerous changes and omissions can be made without departing from the spirit of my invention.

I claim:

100

1. A diaphragm for a horn loud speaker unit of the electro-dynamic type, said diaphragm being made of thin metal and having a peripheral flange by means of which the diaphragm is clamped in the unit, said flange having a reinforcing layer of flexible non-metallic material, the natural period of vibration of said diaphragm being above the audible limit.
2. A diaphragm for a horn loud speaker unit of the electro-dynamic type, said diaphragm being made of thin metal and having a peripheral flange by means of which the diaphragm is clamped in the unit, said flange having a reinforcing layer of flexible non-metallic material, the natural period of vibration of said diaphragm being above the audible limit, said non-metallic material being sufficiently inextensible, so that if it supports said diaphragm due to the cracking of said flange, the natural period of vibration remains above said audible limit.
3. A diaphragm for a horn loud speaker unit of the electro-dynamic type, said diaphragm being made of thin metal and having a peripheral flange by means of which the diaphragm is clamped in the unit, said flange having a reinforcing layer of flexible impregnated fabric, the natural period of vibration of said diaphragm being above the audible limit, said impregnated fabric being sufficiently inextensible, so that if it supports said diaphragm due to the cracking of said flange, the natural period of vibration remains above said audible limit.
4. A diaphragm for a loud speaker unit having a peripheral flange and an inner inclined flange directly adjacent said peripheral flange, and a flexible non-metallic member connected to said inclined flange and to said peripheral flange.
5. A diaphragm for sound reproducing devices comprising a relatively thin disk of material impregnated with a stiffening agent and having a central flanged opening, a metallic, centrally cupped center member secured in said flanged opening and having an integral, annular disk edge and the said disk edge and thin disk being secured together and being of substantially the same diameter.
6. A diaphragm for sound reproducing devices comprising a relatively thin disk of material impregnated with a stiffening agent and having a central flanged opening, a metallic, centrally cupped member secured in said flanged opening and having an integral, annular, radially corrugated disk edge, and the said disk edge and thin disk being secured together and being of substantially the same diameter.

In testimony whereof I affix my signature.

ALEXANDER I. ABRAHAMS.