

(19) **DANMARK**

(10) **DK/EP 3849694 T3**



Patent- og  
Varemærkestyrelsen

(12) **Oversættelse af  
europæisk patentskrift**

- 
- (51) Int.Cl.: **B 01 F 23/233 (2022.01)**      **B 01 F 27/117 (2022.01)**      **B 01 F 27/172 (2022.01)**  
**B 01 F 27/80 (2022.01)**      **B 01 F 27/94 (2022.01)**      **B 01 F 33/503 (2022.01)**  
**B 01 F 101/00 (2022.01)**      **C 02 F 7/00 (2006.01)**
- (45) Oversættelsen bekendtgjort den: **2022-10-17**
- (80) Dato for Den Europæiske Patentmyndigheds bekendtgørelse om meddelelse af patentet: **2022-07-13**
- (86) Europæisk ansøgning nr.: **19813479.3**
- (86) Europæisk indleveringsdag: **2019-11-29**
- (87) Den europæiske ansøgnings publiceringsdag: **2021-07-21**
- (86) International ansøgning nr.: **EP2019083096**
- (87) Internationalt publikationsnr.: **WO2020114907**
- (30) Prioritet: **2018-12-03 DE 202018106871 U**      **2019-01-21 DE 102019101416**
- (84) Designerede stater: **AL AT BE BG CH CY CZ DE DK EE ES FI FR GB GR HR HU IE IS IT LI LT LU LV MC MK MT NL NO PL PT RO RS SE SI SK SM TR**
- (73) Patenthaver: **INVENT Umwelt- und Verfahrenstechnik AG, Am Pestalozziring 21, 91058 Erlangen, Tyskland**
- (72) Opfinder: **HAGSPIEL, Thomas, Bergauer Weg 23, 92353 Postbauer-Heng, Tyskland**  
**FREY, Torsten, Nibelungenstr. 15, 90461 Nürnberg, Tyskland**  
**STEIDL, Walter, Espanstr. 31, 90559 Burgthann, Tyskland**  
**HÖFKEN, Marcus, Platenstraße 22a, 91054 Erlangen, Tyskland**
- (74) Fuldmægtig i Danmark: **Patrade A/S, Ceresbyen 75, 6., 8000 Århus C, Danmark**
- (54) Benævnelse: **HYPERBOLOIDE-RØRELEGEME TIL CIRKULERING AF VÆSKER SAMT RØRE- OG BEGASNINGSANORDNING**
- (56) Fremdragne publikationer:  
**EP-A2- 0 365 013**  
**KR-Y1- 200 447 286**



Hyperboloid agitator for circulating liquids, and agitating and gassing device

5 The invention relates to a hyperboloid agitator body for circulating liquids, in particular water, wastewater or the like. The invention also relates to an agitator and gassing device.

A hyperboloid agitator body and an agitator and gassing device are known for example from DE 202 07 376 U1.

10

In the known agitator and gassing device a motor with a transmission is provided at the tip of a tower-like frame. A transmission shaft is connected to a hollow agitator shaft, at the end of which there is mounted a single-skinned hyperboloid agitator body. The hyperboloid agitator body, on its upper side, has transport ribs running radially in some sections, which transport ribs bend towards the peripheral edge of the agitator body in a tangential direction. Shearing ribs are provided on an underside of the agitator body at the peripheral edge. An annular line is situated beneath the agitator body, through which line air is fed. The air passes through a support element of the tower to the annular line.

20

The known agitator and gassing device requires the provision of a tower-like frame, and for aeration also the provision of an annular line. More specifically, the known agitator and gassing device is suitable for the circulation and gassing of water, wastewater or the like received in a container. By contrast, the known agitator and gassing device is unsuitable in particular for the circulation and gassing of natural bodies of water, such as ponds, lakes and the like, since here there is no solid substrate for supporting the tower-like frame. Apart from that, the known agitator and gassing device is relatively complex from a manufacturing viewpoint. KR 200447286 Y1 discloses a hyperboloid agitator with a hollow body comprising several air outlet openings according to the preamble of claim 1.

25

30

The object of the invention is to overcome the disadvantages of the prior art. In particular, a hyperboloid agitator body and an agitator and gassing device will be described which are suitable universally for circulation and gassing of liquids. In accordance with a further objective of the invention the production in particular of  
5 the agitator and gassing device shall be simplified.

This object is achieved by the features of claims 1 and 15. Expedient embodiments of the invention will become clear from the features of claims 2 to 14.

10 In accordance with the invention the hyperboloid agitator body is formed as a hollow body, wherein a central aperture for feeding air is provided in the connection portion, and wherein an air distribution device for distributing air fed through the aperture towards a plurality of air outlet openings provided in the hollow body is provided downstream of the aperture. Both a circulation and a gassing of liquids is  
15 possible with the hyperboloid agitator body according to the invention. A hollow agitator shaft known *per se* may be used to feed air. In an agitator and gassing device produced with use of the proposed hyperboloid agitator body, it is possible to dispense with the provision of a tower-like frame and a separate annular line for aeration. Such an agitator and gassing device may be produced with reduced ef-  
20 fort. It may be installed easily and quickly *in situ*. In particular it is not necessary to lay any aeration lines under water.

The air distribution device, downstream of the aperture, has an air distribution space with a plurality of air distribution apertures. Each air distribution aperture ad-  
25 vantageously opens out into an air channel, which is delimited by walls running radially in some sections. The walls running radially in some sections bend expediently towards the peripheral edge of the hyperboloid agitator body in a tangential direction. The air outlet openings are expediently each provided at radially outer end portions of the air channels. The proposed design of the hyperboloid agitator  
30 body, in particular the air distribution device, utilises the geometry of the hyperboloid agitator body as far as possible. A compact construction results for the design of the hollow body. The provision of the air outlet openings at the radially outer end

portions of the air channels contributes to a particularly effective gassing of the liquid in question.

5 The hyperboloid agitator body is formed from an upper shell containing the connection portion and a lower shell connected to the upper shell, wherein air channels are delimited by the upper shell and the lower shell. Consequently, the air channels may be produced by simply joining together the upper shell and the lower shell.

10 Transport ribs running radially in some sections expediently extend from the first upper side of the upper shell. The transport ribs may bend – similarly to the walls – towards the peripheral edge of the hyperboloid agitator body in a tangential direction. The walls expediently extend from a second upper side of the lower shell. In accordance with a particularly advantageous embodiment, the course of the walls  
15 corresponds to the course of the transport ribs, such that, when the upper and lower shells are joined, each transport rib underside is supported on an upper edge of one of the walls. This thus results in a particularly stable and torsion-resistant construction. Furthermore, the air channels may thus be produced in a simple way by joining the upper shell to the lower shell. The walls may also have  
20 openings or may be formed from a number of portions, with gaps situated in-between.

In accordance with a further advantageous embodiment the second upper side of the lower shell is formed in concave, preferably hyperboloid-like fashion. In other  
25 words both the upper side and the underside may be formed in hyperboloid-like fashion. A particularly compact and stable hollow body is provided when the upper shell is joined to the lower shell.

The air outlet openings are expediently provided in the vicinity of a peripheral edge  
30 of the hollow body. In particular, the air outlet openings may be provided in the vicinity of a peripheral edge of the lower shell, in particular on a second underside of

the lower shell opposite the second upper side. Shearing ribs extending radially outwardly are expediently attached to the second underside.

At least one of the air outlet openings is expediently provided between 2 shearing  
5 ribs. Due to the proposed arrangement, air bubbles exiting through the air outlet openings are destroyed immediately by the effect of the shearing ribs and/or are distributed finely in the surrounding liquid. A particularly efficient gassing of the liquid is thus achieved.

10 The upper and the lower shells may each be produced from fibre-reinforced plastic. In accordance with an expedient embodiment the air distribution space is formed from a rotationally symmetrical, preferably conical insert, with the air distribution apertures provided in the peripheral wall of said insert. The insert may also be produced from fibre-reinforced plastic. Consequently, the hollow body may be  
15 produced easily from few parts, specifically the upper shell, the lower shell and the insert, for example by gluing.

In accordance with the invention an agitator and gassing device is also proposed, comprising

20

a motor,

a transmission connected drivingly to the motor and having a transmission hollow shaft,

25

a fan connected to a first end of the transmission hollow shaft and provided for feeding air,

an agitator shaft connected to a second end of the transmission hollow shaft, and

30

a hyperboloid agitator body according to the invention attached to a third end of the agitator shaft.

The proposed agitator and gassing device is of simple structure. It may be quickly assembled. It may be assembled on a raft, for example for the circulation and gassing of bodies of water.

5

Exemplary embodiments of the invention will be explained in greater detail hereinafter with reference to the drawing, in which:

Fig. 1 shows a partially broken-open perspective view of a hyperboloid agitator  
10 body,

Fig. 2 shows a plan view of an upper shell,

Fig. 3 shows a view from below according to Fig. 2,  
15

Fig. 4 shows a plan view of a lower shell,

Fig. 5 shows a view from below according to Fig. 4 and

20 Fig. 6 shows a schematic sectional view through a transmission.

In Fig. 1 a hyperboloid agitator body is attached to a hollow agitator shaft 1. The hyperboloid agitator body has a central connection portion denoted by reference sign 2. The connection portion 2 has a central aperture 3 for the passage of air.

25

Reference sign 5 denotes an upper shell, with transport ribs 6 extending from the first upper side O1 of the upper shell. Reference sign 7 denotes a lower shell, with walls 8 extending from the second upper side O2 of the lower shell. Reference sign 9 denotes an insert which is provided downstream of the aperture 3 and  
30 forms an air distribution space 4. The insert 9 is formed in the manner of a conical beaker and has a plurality of air distribution apertures 10 on its peripheral wall. Each of the air distribution apertures 10 opens out into an air channel 11 formed

by adjacent walls 8 as well as the upper shell 5 and the lower shell 7. Shearing ribs 12 are attached to a second underside U2 of the lower shell 7 at the peripheral edge thereof.

5 Fig. 2 shows a plan view of the first upper side O1 of the upper shell. The transport ribs extending from the first upper side O1 can be seen and run from the aperture 3 firstly in a radial direction and then bend towards the peripheral edge U in a tangential direction. The insert 9 arranged downstream of the aperture 3 and having the air distribution apertures 10 is also visible.

10

Fig. 3 shows a lower view according to Fig. 2. The transport ribs 6 in the form of indentations are visible on a first underside U1 of the upper shell 5.

15 Fig. 4 shows a plan view of the second upper side O2 of the lower shell 7. The lower shell 7 is closed at its centre, i.e. opposite the aperture 3 provided in the upper shell 5. The walls 8 extend from the second upper side O2. The walls 8 – similarly to the transport ribs 6 – run from the centre firstly in a radial direction and then bend towards the peripheral edge U in a substantially tangential direction. A plurality of holding devices 13, which form indentations in the second upper side O2, are  
20 situated at the peripheral edge U. The holding devices 13 are used – as can be seen in particular from Fig. 5 explained hereinafter – to receive and fasten the shearing ribs 12.

25 Fig. 5 shows a view from below according to Fig. 4. On a second underside U2 of the lower shell, the walls 8 in the form of indentations are visible. The holding devices 13 by contrast extend from the second underside U2. Reference is also made in this regard to Fig. 1. An air outlet opening 14 is provided between each two adjacent holding devices 13 or each two adjacent shearing ribs 12.

30 Fig. 6 shows a schematic sectional view through a transmission 16, which is connected drivingly to a motor 15. The transmission 16 has a transmission hollow shaft 17, the first end of which is connected to an air feed line 18. A fan connected

to the air feed line 18 is not shown here. A second end E2 of the transmission hollow shaft 17 is connected to the hollow agitator shaft 1. As can be seen from Fig. 1, a third end E3 of the hollow agitator shaft 1 is connected to the hyperboloid agitator body shown in Fig. 1 to 5.

5

The agitator and gassing device discernible in particular from Fig. 1 and 6 may be attached for example to a raft 19 (see Fig. 6). A body of water, for example a pond, lake or the like, may thus be efficiently circulated and gassed.

10

## List of reference signs

	1	agitator shaft
	2	connection portion
5	3	aperture
	4	air distribution space
	5	upper shell
	6	transport rib
	7	lower shell
10	8	wall
	9	insert
	10	air distribution aperture
	11	air channel
	12	shearing rib
15	13	holding device
	14	air outlet opening
	15	motor
	16	transmission
	17	transmission hollow shaft
20	18	air feed line
	19	raft
	E1	first end
	E2	second end
25	E3	third end
	O1	first upper side
	O2	second upper side
	U1	first underside

**Patentkrav**

1. Hyperboloide-rørelegeme til cirkulering af væsker, særligt vand, spildevand eller lignende, i hvis centrum der er tilvejebragt et tilslutningsafsnit (2) til tilslutning til  
5 en hul omrører (1),

hvor hyperboloide-rørelegemet er udformet som et hult legeme, hvor der i tilslutningsafsnittet (2) er tilvejebragt en central gennembrydning (3) til tilførsel af luft,

10 hvor der nedstrøms for gennembrydningen (3) er tilvejebragt en luftfordelingsanordning (9, 10, 11) til fordeling af luft tilført via gennembrydningen (3) til flere luftudstrømningsåbninger (14) tilvejebragt i det hule legeme,

**kendetegnet ved,**

15 **at** hyperboloide-rørelegemet er dannet af en overskal (5), som indeholder tilslutningsafsnittet (2), og en hermed forbundet underskal (7), hvor luftkanalerne (11) begrænses af over- (5) og underskallen (7).

2. Hyperboloide-rørelegeme ifølge krav 1, hvor luftfordelingsanordningen (9, 10, 11) nedstrøms for gennembrydningen (3) har et luftfordelingsrum (4) med flere  
20 luftfordelingsgennembrydninger (10).

3. Hyperboloide-rørelegeme ifølge krav 2, hvor hver luftfordelingsgennembrydning (10) udmunder i en luftkanal (11), som er begrænset af vægge (8), som afsnitvist strækker sig radiale.  
25

4. Hyperboloide-rørelegeme ifølge krav 3, hvor luftudstrømningsåbningerne (14) hver er tilvejebragt på radiale udvendige endeafsnit af luftkanalerne (11).

5. Hyperboloide-rørelegeme ifølge et af de foregående krav, hvor der strækker sig transportribber (6), som afsnitvist forløber radiale fra den første overside (O1) af  
30 overskallen (5).

6. Hyperboloide-rørelegeme ifølge et af kravene 3 til 5, hvor væggene (8) strækker sig fra en anden overside (O2) af underskallen (7).  
35

7. Hyperboloide-rørelegeme ifølge et af kravene 3 til 6, hvor forløbet af væggene (8) svarer til forløbet af transportribberne (6), sådan at hver

transporttribbeunderside støtter sig på en respektiv overkant af væggene (8), når over- (5) og underskallen (7) samles.

5 8. Hyperboloide-rørelegeme ifølge et af de foregående krav, hvor den anden overside (O2) af underskallen (7) er formet konkavt, foretrukket hyperboloidelignende.

9. Hyperboloide-rørelegeme ifølge et af de foregående krav, hvor der på en anden underside (U2) af underskallen (7), som ligger modsat den anden overside (O2), er anbragt skæreribber (12), som strækker sig radiale udad.

10

10. Hyperboloide-rørelegeme ifølge et af de foregående krav, hvor luftudstrømningsåbningerne (14) er tilvejebragt i nærheden af en omkredskant (U) af underskallen (7).

15 11. Hyperboloide-rørelegeme ifølge et af kravene 9 eller 10, hvor der mellem hver to skæreribber (12) er tilvejebragt en af luftudstrømningsåbningerne (14).

12. Hyperboloide-rørelegeme ifølge et af de foregående krav, hvor over- (5) og underskallen (7) hver er fremstillet af fiberforstærket plast.

20

13. Hyperboloide-rørelegeme ifølge et af kravene 2 til 12, hvor luftfordelingsrummet (4) er dannet af en rotationssymmetrisk, foretrukket konisk, indsats (9), i hvis omkredsvæg luftfordelingsgennembrydningerne (10) er tilvejebragt.

25 14. Hyperboloide-rørelegeme ifølge krav 13, hvor indsatsen (9) er fremstillet af fiberforstærket plast.

15. Røre- og begasningsanordning, omfattende

30 en motor (15),

en transmissionsenhed (16) drivmæssigt forbundet med motoren (15) med en hul transmissionsomrører (17),

en blæser til tilførsel af luft, forbundet med en første ende (E1) af den hule transmissionsomrører (17),

35 en omrører (1) forbundet med en anden ende (E2) af den hule transmissionsomrører (17) og

et hyperboloide-rørelegeme ifølge et af de foregående krav anbragt i en tredje ende (E3) af omrøreren (1).

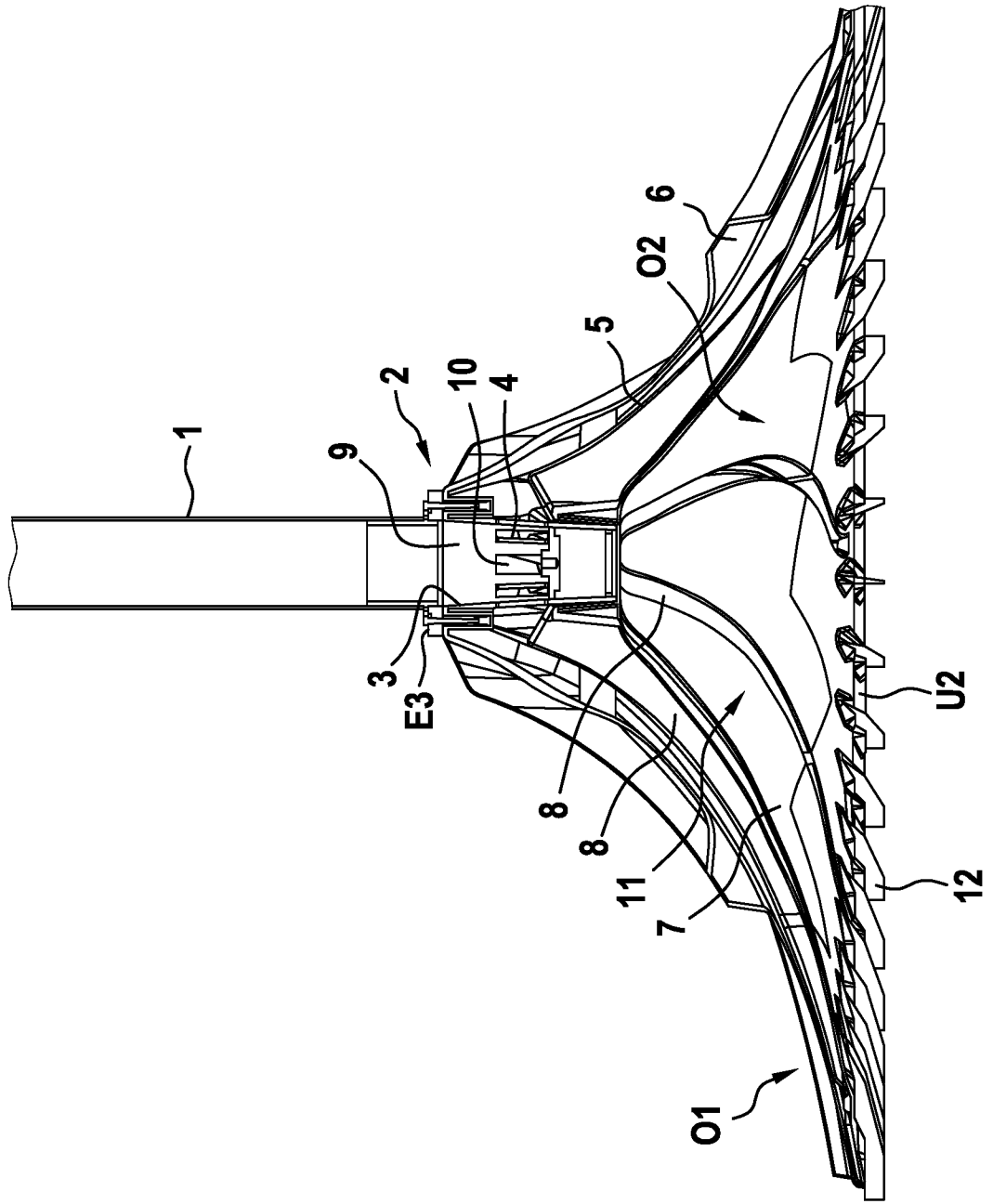

Fig. 1

Fig. 2

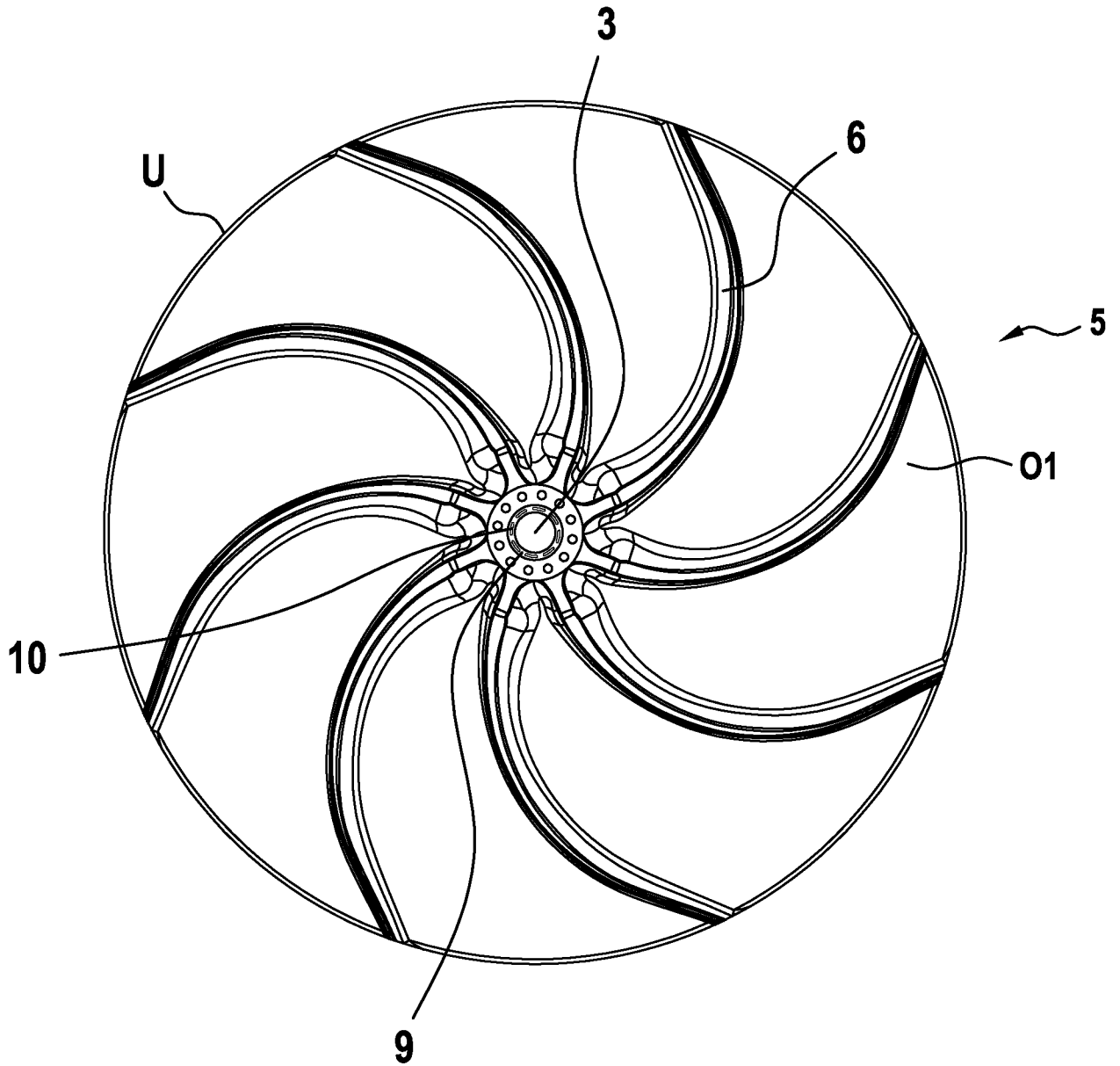

Fig. 3

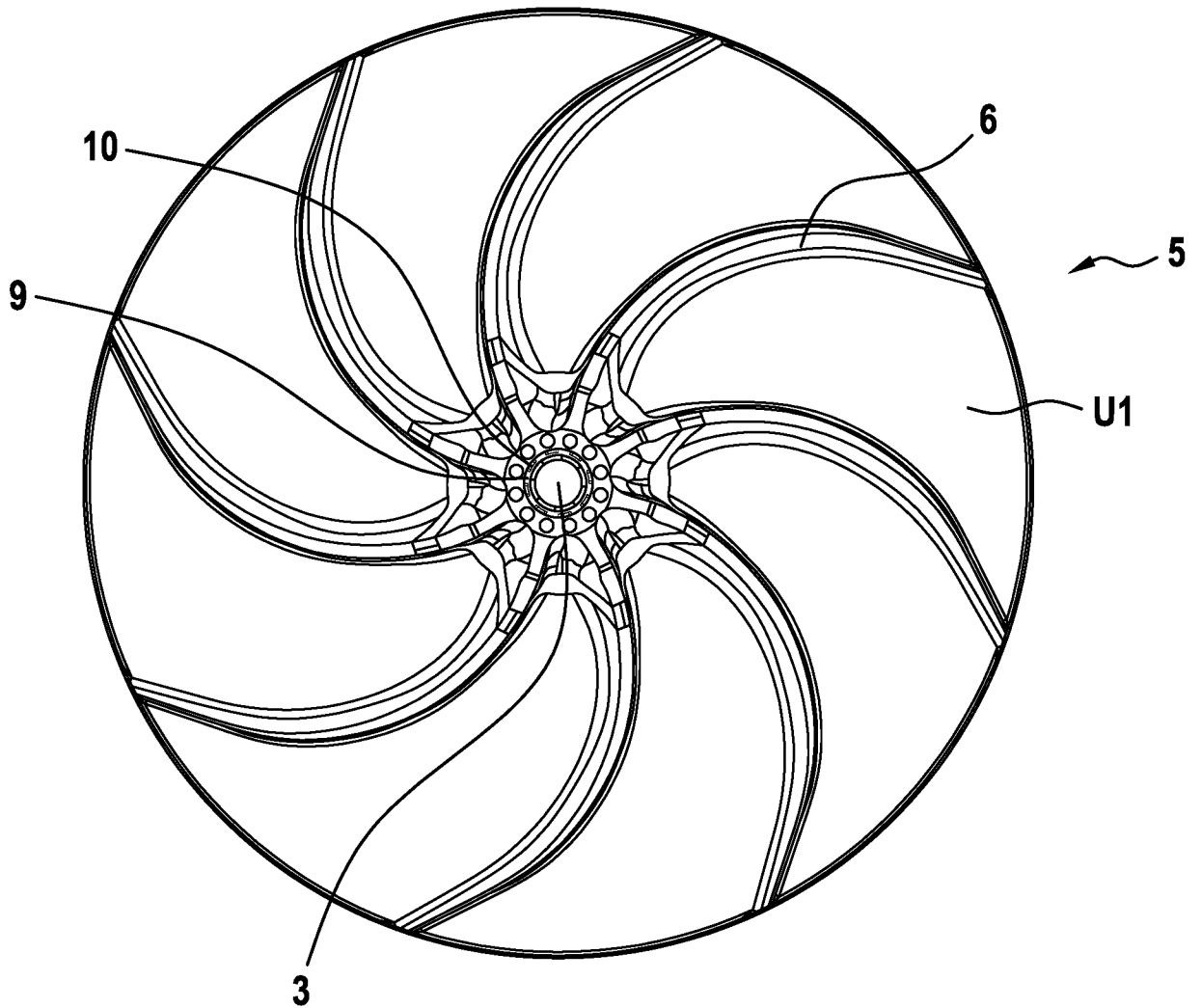

Fig. 4

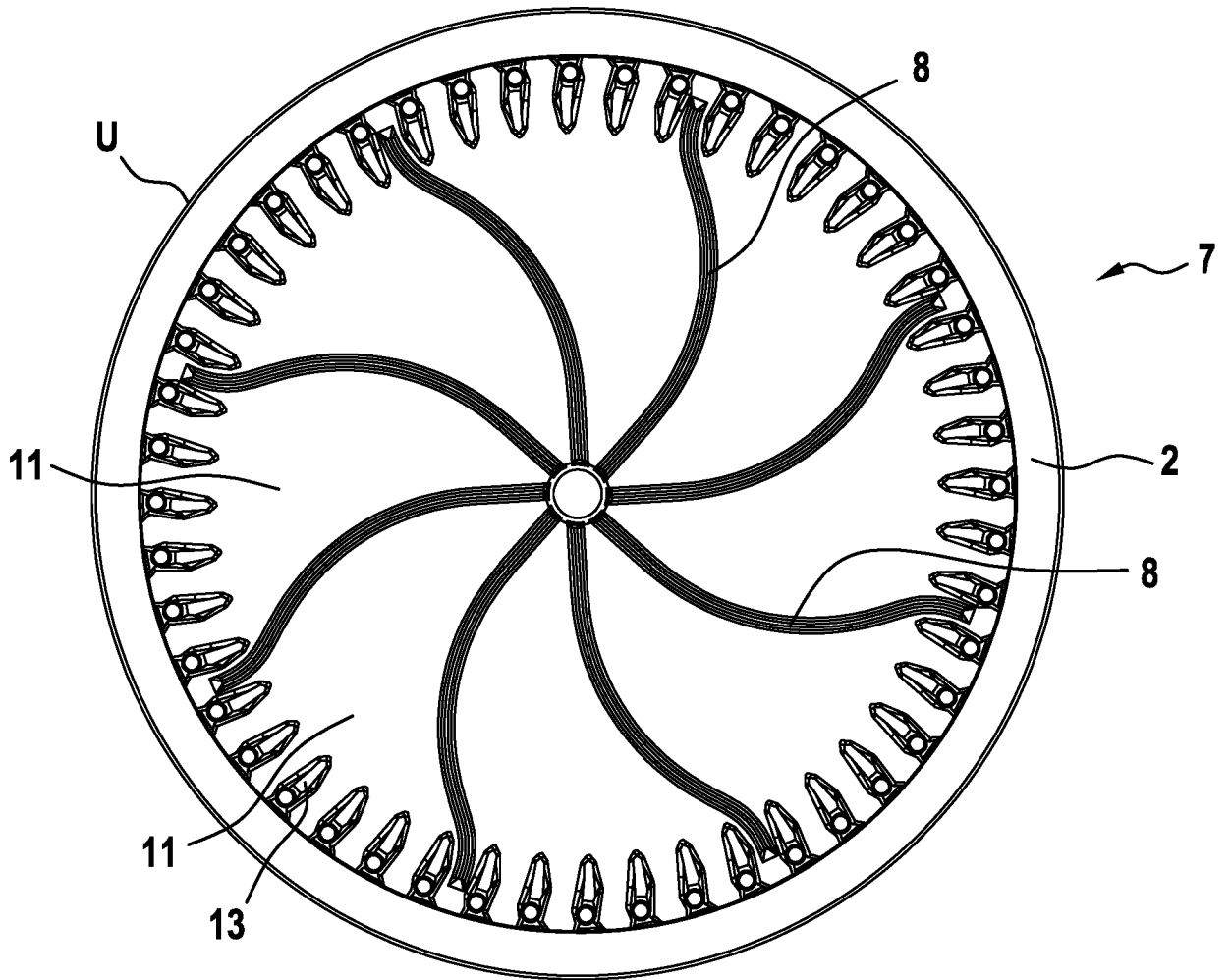

Fig. 5

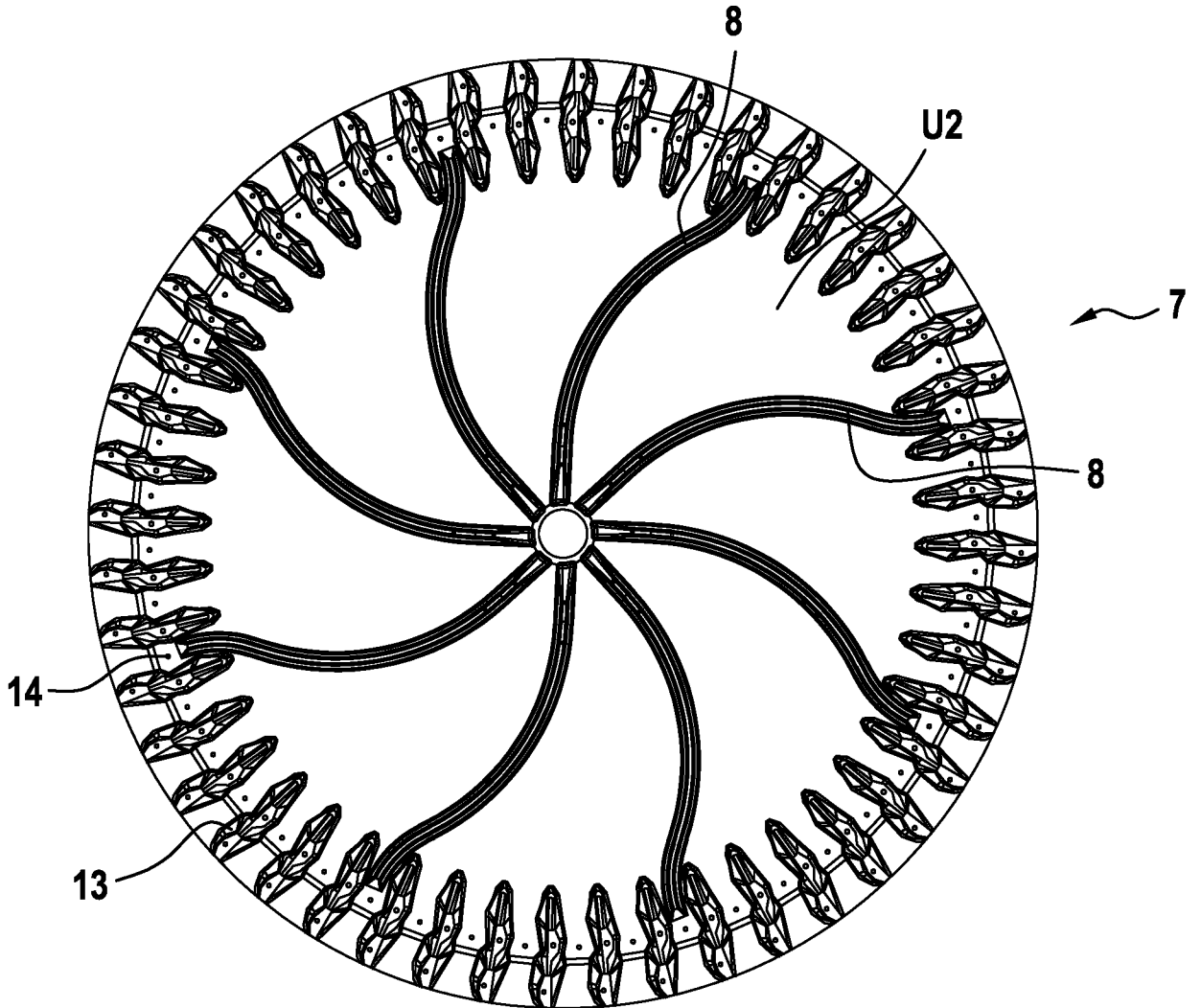

Fig. 6

