

(No Model.)

W. G. PRICE.
STOVE TOP.

No. 523,375.

Patented July 24, 1894

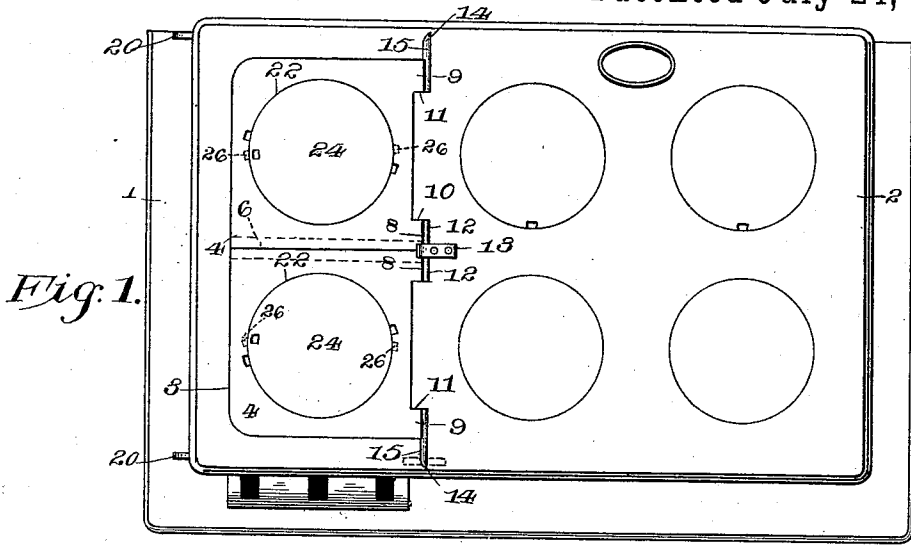

Fig. 1.

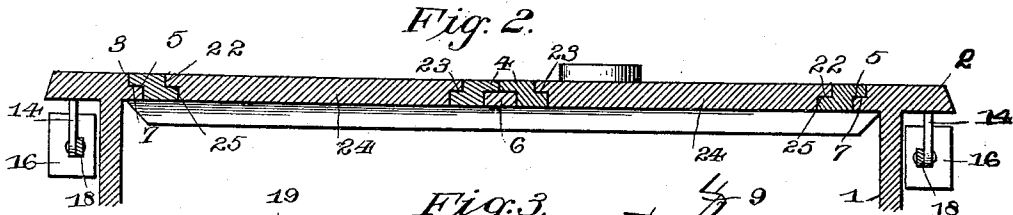

Fig. 2.

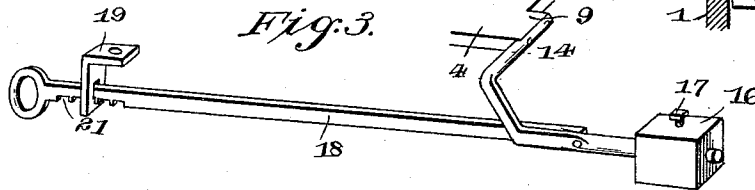

Fig. 3.

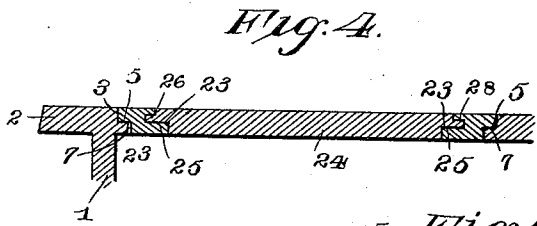

Fig. 4.

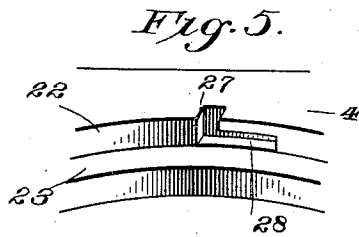

Fig. 5.

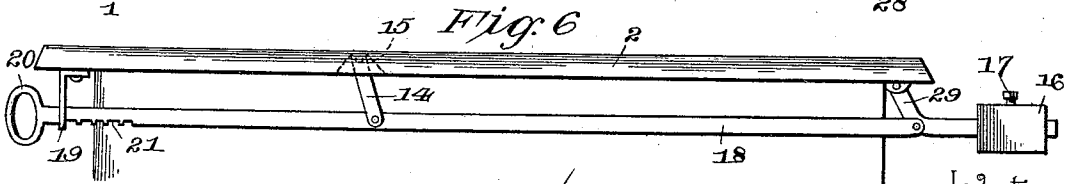

Fig. 6.

Inventor

Witnesses

Chas. Ford.
J. B. B. B.

By his Attorneys.

William G. Price,

C. Brown & Co.

UNITED STATES PATENT OFFICE.

WILLIAM G. PRICE, OF FRACKVILLE, PENNSYLVANIA.

STOVE-TOP.

SPECIFICATION forming part of Letters Patent No. 523,375, dated July 24, 1894.

Application filed March 26, 1894. Serial No. 505,167. (No model.)

To all whom it may concern:

Be it known that I, WILLIAM G. PRICE, a citizen of the United States, residing at Frackville, in the county of Schuylkill and State of Pennsylvania, have invented a new and useful Stove-Top, of which the following is a specification.

My invention is related to an improvement in that class of stove tops which are mounted so as to be capable of swinging on the stove; and the object is to provide improved means for effecting this operation, and such that may be operated with greater ease, and be less liable to disorder.

To these ends the invention consists in the peculiar mode of combining the top with a counterbalancing weight and operating rod, all of which will be more fully described hereinafter, and finally embodied in the claims.

In the accompanying drawings:—Figure 1 represents a plan view of a stove supplied with my improvements; Fig. 2 a cross-section of the top looking rearwardly; Fig. 3 a perspective view of the counterbalancing weight and operating lever showing the connection with the swinging lid; Fig. 4 a detail section showing the construction of the lids and top; Fig. 5 a detail perspective further illustrating this point; Fig. 6 a view of a second species of lever and weight mechanism.

The reference numeral 1 indicates the body of the stove, which may be constructed in any preferred way, and is provided with the top proper 2. Formed in the top 2 and extending over the entire space occupied by the fire, is the opening 3, which is rectangular in shape and adapted for the reception of the independently movable lid frames 4. These devices 4 are preferably two in number and of the same size and shape and operate to jointly fill the opening 3.

Formed around the edge of the opening 3 is the rabbet-groove 5, which extends around the entire edge of the opening, and, together with the cross-bar 6, operates to support the frames 4, they being adapted to lie in the rabbet-groove 5, so as to be flush with the upper surface of the top 2. The frames 4 are also formed with a rabbet-groove 7, which corresponds with the groove 5, and is adapted to lie therein.

Formed on the rear side of the frames 4, and at each end thereof, are the lugs 8 and 9, which project rearwardly therefrom, and are arranged in the recesses 10 and 11, formed for their reception in the top 2. The recess 10 is in the center of the top and adapted for the reception of both the lugs 8 of each frame, while recesses 11 are two in number, one at each side, and adapted respectively for the reception of the adjacent lugs 9.

Secured rigidly to the lugs 8, and projecting a short distance inward therefrom are the trunnions 12, which are one for each lug, and are embraced at their inner ends by the plate 13 secured to the top 2 just rearward of recess 10, and projecting forwardly and downwardly so as to form a hook for embracing the trunnions 12. By this means the inner corners of the frames 4 are pivoted in place and allowed to swing on such pivots, as will more fully appear hereinafter.

The lugs 9 are each provided with the trunnions 14, which are secured thereto, and which project out laterally from the lugs through the recesses 11 and through the passages 15, formed in the side of the top 2 and extending nearly to the edge thereof. From the end of the passages 15 the trunnions 14 extend downwardly and rearwardly for a slight distance, and then curve horizontally and rearwardly, and are provided at such horizontal portions with the weights 16. These weights are adjustable on the rods or trunnions 14 by means of the set-screws 17, whereby the force exerted by the weights may be regulated, as is well understood. Pivotaly connected to each of the trunnions 14, at the point where the horizontal and rearward portions begin, are the longitudinal rods 18. These rods 18 are two in number, one for each trunnion 14, and the connection therewith may be by any means, it being, of course, essential that it be a pivotal one. From the trunnions 14 the rods 18 extend forward and through the eyes 19 on the front edge of the stove; after which they are formed with the bails or handles 20 at their extreme forward ends. The function of the eyes 19 is of a two-fold character, viz., to furnish a support for the front ends of the rods 18, and to co-operate with the teeth 21, formed on the under side of the rods. These

teeth 21 extend for a short distance along the rod, and by their means it may be locked at various longitudinal positions.

Formed in the frames 4, and occupying the major portion of the same, are the circular openings 22, which are each formed with the rabbet-grooves 23 in their periphery. These openings 22 are adapted for the reception of the lids 24, which are of a size equal to that of the openings, and formed with the downwardly opening rabbet-grooves 25 therein. These are adapted to match with the grooves 23, and to form a tight joint therewith. In order that the lids 24 be retained in their proper places when the frames 4 are raised I provide the lids with the studs 26, which are located oppositely on their widest periphery and are adapted to pass through the notches 27 in the edge of the openings 22. Formed in the openings 22 and directly adjacent to the notches 27 are the horizontal slots 28 which extend in opposite directions from the notches 27, and are adapted to receive and retain the studs 26.

The lids 24 are placed in the openings 22, so that the studs 26 register with notches 27, and allowed to pass down as far as possible, whereupon the lids are turned to engage the studs 26 and slots 28, and by these means the lids are held in place.

To remove the lids they are turned in an opposite direction, thus disengaging the studs and slots, and permitting the complete removal of the lids. It will be seen that the rods 18 are arranged on the outside of the stove and parallel with the sides, so that they are protected from the excessive heat of the fire-box and allowed free movement in their respective lines.

To raise the frames 4 and their attached lids, the rods 18 are slightly raised to disengage the teeth 21 and eyes 19 and make it possible to move the rods forward. This operation will swing rods 14 downwardly and forwardly and cause the frames 4 to be raised, thus opening the top of the stove. Both of the frames may be raised, or they may be allowed to operate independently if so desired. The weights 16 are to be of sufficient size to nearly counterbalance the frames 4 and their attached lids, so that but little force is required to lift the frames. By means of the teeth 21 and eyes 19 the frames 4 may be partially raised and held so, in order to permit the entry of air into the fire-box, when desired to cool off the stove.

The form of my invention, which is shown in Fig. 6, is a means whereby the counterbalancing weight may be placed at the rear of the stove, as may be necessary or preferred in some cases. To effect this the trunnion-rods or levers 14 are not bent horizontally be-

low the top 2, but are pivotally connected to the rods 18 at their lower ends. From the levers 14 the rods 18 extend rearwardly to the rear side of the stove, and are there pivoted to the bend in the auxiliary levers 29, which are formed with longitudinally and rearwardly extending portions provided with the weights 16, as in the other form. The remaining ends of levers 29 are bent upwardly and pivoted to the rear of the stove. Thus the frames 4 are counter-balanced, and the rods 18 in position to be reached, so as to raise the frames.

Having thus described my invention, what I claim as new, and desire to secure by Letters Patent, is—

1. The combination with a stove top having an opening formed therein, a lid frame arranged in the opening, a rod rigidly secured at one end to the frame and extending out horizontally to form a trunnion and thence downwardly and horizontally, a weight fixed to the downward and horizontally extending portion, and a second rod pivotally connected to the first and extending forwardly therefrom, whereby the rod may be swung on its trunnion and the lid frame raised, substantially as specified.

2. The combination with a stove top having an opening formed therein and extending entirely over the fire-box, of two independently movable lid frames arranged in the opening, and adapted to cover or uncover the same, and independently operating rods pivotally connected to the frames, whereby each may be raised or lowered irrespective of the position of the other, substantially as specified.

3. The combination with a stove having an opening in its top, of a lid frame hinged to the stove and adapted to close the opening therein, a counterbalancing weight connected to the lid frame and operating to help it move upwardly, and a rod connected to the lid frame and capable of being moved to raise the same, substantially as specified.

4. The combination with a stove top having an opening formed therein, of a lid frame fitting in the opening, trunnions on the frame and journaled in the stove top, whereby the frame may swing to cover and uncover the opening, and an operating rod connected to the frame and adapted to furnish a means for manipulating the same, substantially as described.

In testimony that I claim the foregoing as my own I have hereto affixed my signature in the presence of two witnesses.

WILLIAM G. PRICE.

Witnesses:

H. K. WESTON,
GEORGE S. RABER.