

(19) World Intellectual Property Organization
International Bureau



(43) International Publication Date
14 March 2002 (14.03.2002)

PCT

(10) International Publication Number
WO 02/20351 A1

- (51) International Patent Classification⁷: **B65B 1/04** (72) Inventors: **SHAPOVALOV, Vladimir, I.**; 6450 East Golf Links Road, Tucson, AZ 85730 (US). **LOUTFY, Raouf, O.**; 6507 N. Ventana Canyon Drive, Tucson, AZ 85750 (US).
- (21) International Application Number: PCT/US01/27422
- (22) International Filing Date: 4 September 2001 (04.09.2001) (74) Agent: **TEPLITZ, Jerome, M.**; 6740 East Bacobi Circle, Tucson, AZ 85750 (US).
- (25) Filing Language: English (81) Designated States (*national*): CA, JP.
- (26) Publication Language: English (84) Designated States (*regional*): European patent (AT, BE, CH, CY, DE, DK, ES, FI, FR, GB, GR, IE, IT, LU, MC, NL, PT, SE, TR).
- (30) Priority Data:
09/658,511 8 September 2000 (08.09.2000) US
09/945,251 31 August 2001 (31.08.2001) US
- (71) Applicant: **MATERIALS AND ELECTROCHEMICAL RESEARCH (MER) CORPORATION** [US/US]; 7960 South Kolb Road, Tucson, AZ 85706 (US).
- Published:**
— with international search report
- For two-letter codes and other abbreviations, refer to the "Guidance Notes on Codes and Abbreviations" appearing at the beginning of each regular issue of the PCT Gazette.*

(54) Title: METHOD AND APPARATUS FOR STORING COMPRESSED GAS

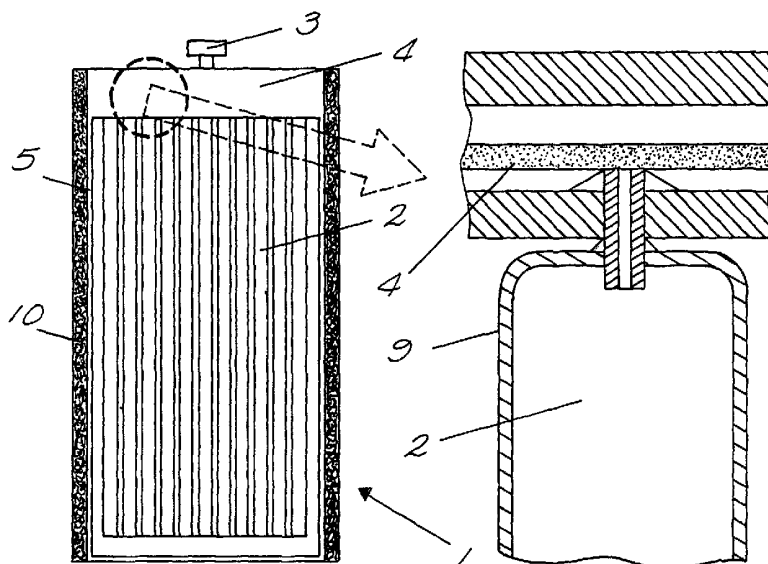

(57) Abstract: A compressed gas such as hydrogen is stored at elevated pressure by introducing it into a plurality of storage cells (2) having a common gas distribution manifold (3) thereby maintaining the same pressure in all cells. The flow of gas between the manifold in any given cell is blocked in the event of a sudden pressure drop in such cell such as may occur in the event of a leak in the cell. Preferably, the cells are constructed in modular form (1) to include a plurality of the cells (2) and the modular material is preferably made of porous gasar material. The low pressure, i.e., leaky cell, is preferably blocked by a closure (4) formed of pliable rubber like material that is forced against the passageway leading from the manifold (3) to the cell (2) by higher gas pressure in the manifold, which occurs when the pressure becomes lower in the given cell due to a leak.



WO 02/20351 A1

METHOD AND APPARATUS FOR STORING COMPRESSED GAS

The present invention relates to a method of containing compressed gas and to systems for carrying out such containment; and, particularly to such method and systems for storing hydrogen and other potentially explosive gases in a safe environment.

BACKGROUND OF THE INVENTION

The problem of creating safe, capacious and convenient storage for compressed gas (predominantly hydrogen), is one of the most important aspects of hydrogen energy development [1-3]. Some hydrogen storage methods currently available are [4-8]:

- Compressed gaseous hydrogen in gas-cylinders;
- Liquid hydrogen at low temperatures in Dewar flasks;
- Chemically combined hydrogen in hydride powder canisters;
- Physical-chemical absorbed hydrogen in carbon nanotubes.

Each of these methods has merits and demerits. Hydride storage material is capable of spontaneous ignition in air. They show complexities associated with the accumulation and extraction of hydrogen. Finally, they are so very expensive that they can not be considered for large-scale use as a hydrogen storage medium.

The most convenient storage method is hydrogen high-pressure (15-25MPa) storage in steel gas-cylinders. There are many types of gas storage cylinders, which contain toxic and other hazardous gases or liquids [9-18]. These cylinders fill and empty quickly without complications. However, the important weakness of this method is the danger of explosively

rapid release of gas. The second (related) weakness of steel gas-cylinders is their limited mass fraction storage capacity. They are made heavier than required for pressure retention to ensure safety against impact, puncture or crushing damage.

OBJECTS AND ADVANTAGES OF PRESENT INVENTION

A primary object of the present invention is the creation of a new cellular storage system for compressed gas, which will combine safety with high capacity and yet be inexpensive and convenient, for use in aircraft and spacecraft. Such storage systems can be utilized also for ground vehicles as a hydrogen source for fuel cell electric generation.

SUMMARY OF THE INVENTION

In accordance with the present invention, by providing a storage system comprising a plurality of gas tight cells, preferably in modules, rather than a single gas cylinder of equivalent capacity, the danger of sudden total gas release will be reduced and the safety margin can therefore be reduced accordingly. The result is a much higher weight fraction of storage.

The idea of using a storage system with a plurality of cells formed of material having cellular structure as the basic gas storage block (cellular module) is the scientific and technical basis of a preferred aspect of this invention.

Multi cellular organisms demonstrate much more stability against environment negative impact than unicellular organisms. This principle underlies our invention. Therefore we have named our new device a Safe Cellular Storage (further – SCS).

The present invention is also embodied in the design of a system which incorporates means for automatically isolating destroyed gaseous storage cells from healthy cells, so that the SCS as a whole would remain efficient. This problem is solved by the system described and claimed below.

BRIEF DESCRIPTION OF THE DRAWINGS

Figure 1 is a diagrammatic view of various gasar structures that can be used in carrying out the various embodiments of the present invention;

Figure 2 is a diagrammatic illustration of the relationship between the pore size and the amount of porosity in various porous metals;

Figure 3 is a diagrammatic illustration showing the design of gasar SCS with cylindrical radial porosity without refuel module;

Figure 4 is a diagrammatic illustration of a design of gasar SCS with parallel porosity without refuel module;

Figure 5 is a diagrammatic design of two views of multi celled storage system using gasar SCS with spherical radial porosity with refuel module and one collector;

Figure 6 is a diagrammatic illustration of the stop module (smart rubber) in operation;

Figure 7 is a diagrammatic design of gasar SCS with spherical radial porosity with refuel module and two collectors;

Figure 8 is a diagrammatic design of gasar SCS with ellipsoidal and irregular parallel porosity with refuel module, one stop module and one collector;

Figure 9 is a diagrammatic design of gasar SCS with ellipsoidal and irregular cylinder parallel porosity with one refuel module, two stop modules, and two collectors;

Figure 10 is a diagrammatic illustration showing the fraction of hydrogen in tubular SCS and different pressures at tube materials;

Figure 11 is a diagrammatic illustration of the design of tubular SCS

Figure 12 is a diagrammatic illustration showing a SCS net storage system design;

Figure 13 is a diagrammatic illustration of a tubular SCS net design with complex shape.

DETAILED DESCRIPTION OF THE PREFERRED EMBODIMENTS

The requirements of the gaseous cells for carrying out the present invention should preferably include the following:

- Total amount of gas in each cell should not exceed 10 liters (at 1 atmosphere and 20⁰C);
- It should preferably have the compact tubular shape for security of optimal stress distribution in walls of cells;
- The cell walls should be impermeable for stored gas;
- The cell walls should have sufficient toughness to hold out high pressure inside the cells.
- The cell walls should not chemically interact with stored gas;
- Each cell should advantageously have a mechanism for automatically and very promptly sealing it from other cells, after a sharp decrease of gas pressure in it as a result of destruction.

The multi cellular modules can be produced using various materials in several different ways, including the following:

- Some natural porous materials;
- From monolithic structures by formation of cells of the necessary size and shape in the structure ;
- Plastic deformation;

- Founding technologies;
- Methods of powder metallurgy;
- Rapid-Prototyping technology.

It is possible also to make such cellular modules of separate tubes with gas-proof walls.

It is particularly advantageous to realize this invention by utilizing new porous materials, especially gasars and tubular variant.

As model gas to illustrate the use of this invention we have selected hydrogen, as this gas gains the increasing distribution for use in aircraft and ground transport. But all calculations and reasoning, reduced below, will be valid for all other gases as well.

The method of storing compressed gases comprising charging with gas at elevated pressure a storage system (Safety Cellular Storage – SCS) includes:

- Distributing all volume of the gas in SCS in numerous gas cells, such that each cell has gas volume, which at destruction a cell does not explode;
- The cells are maintained in communication with outside atmosphere in such a manner that the gas can leave them by flowing only in one direction;
- In a preferred embodiment, the direction of gas flow is such, that at destruction of any given cell and reverting dropping of gas pressure in this cell, the given cell will be isolated from the other cells, thereby preserving the former high gas pressure in these other cells.

The SCS comprises (Figures 3-13):

- A cellular module 1 having cellular structure, comprising gaseous cells 2 isolated from each other within the module, and in which is stored a main mass of gas;
- Minimum one collector 3 ensuring an opportunity of a filling up of SCS by gas and release of the gas for the use;
- Minimum one “stop module” 4 which is located between the collector 3 and the cellular module 1, and ensuring self-acting instantaneous sealing of the destroyed cells 2 from the rest of the

The cellular structure should be formed by uninterrupted (inside of the cellular module 1) cells 2 which have geometrical similar orientation like spherical radial orientation, cylindrical radial orientation, or parallel alignment. The cell shape should be tubular and can be cylindrical, cone-shaped, ellipsoidal, irregular cylinder, three-edged, rectangle, square, or polyhedral.

The cell walls should be impermeable (gas-proof) and have average size in section from 10 microns up to 20 mm.

GASAR SCS

New porous materials, known as **gasars** [19,20], answer almost all the requirements for making cells for storing gas, such as hydrogen, in accordance with the present invention. The high strength and various structure (Figure 1) of materials, results from the smoothly rounded pore shape, the mirror smooth pore surface finish and the absence of porosity in the interpore spaces. An additional advantage is the cleanliness of the base material [9-14]. The present invention will demonstrate the opportunities arising from this high-pressure hydrogen storage without the risk of explosive gas release. For this purpose it is most appropriate to utilize gasars with cylindrical or ellipsoid pores with diameters of 1-10 millimeters and porosity levels of 60-90 %. Charged by hydrogen under a pressure of 60-95 MPa they can

have capacitance 4-8 % of hydrogen by mass. Being subdivided in micro cylinders, such stored hydrogen will be secure even at 100 MPa pressure.

Figure 2 compares the pore size and pore fraction range possible to gasars with other porous materials. Gasar pore size may be varied between 30 μ m and 8mm as desired, and the amount of porosity may reach 80%. They differ from other porous metals by the larger variety of structures and pore space parameters available, by the lower cost and the higher strength. The pore wall surface is always clean. In most cases it shows a high luster but is sometimes not entirely smooth due to the exposure of growth dendrites. The interpore walls are free of any secondary porosity or undesirable inclusions.

The relationship between the average pore diameter and the amount of porosity is an important structural characteristic. A summary of these data for various porous metals, including gasars, is presented in Figure 2. No method is presently available for making porous metals that combine ultra fine pore size with a high void fraction. Clearly, the existing technologies are complementary in that each of them is applicable to a specific area of engineering application. The metallic matrix of gasars can be iron, nickel, magnesium, aluminum, copper, beryllium and their alloys. It is especially important, that the gasar castings can have a mixed porous-solid structure with a solid skin and a porous core, as is shown in Figure 3 and others.

Mechanical tests of gasars have shown that their directional pores of below 10mm in diameter make them superior in resistance to buckling failure to monolithic materials having the same mass and composition. Generally this provides a saving in scarce materials. In addition, gasars are well suited both for machining and for cold forming. They respond to

hardening by conventional heat treatment. They can be produced with a directional heat conductivity value lower or greater than that of the monolithic material and they have a good capacity to absorb vibrations and sounds.

One form of storage cell structure according to the present invention utilizes the gasar SCS with radial cylindrical cellular module 1 as shown in Figure 3. This SCS has solid skin 5, one collector 3, one stop module 4 made of thin wall rubber membrane in the form of a hollow sleeve or tube. Each gas cell 2 has conic shape. The collector 3 is joined to cellular module 1 at an opening 6 in solid skin 5.

Gasar SCS with parallel cellular module 1 is shown in Figure 4. This SCS has solid skin 5, one collector 3, one stop module 4 made of thin rubber membrane. Each gas cell 2 has cylindrical shape and different sectional size.

Gasar SCS with spherical radial cellular module 1 is shown in Figure 5. This SCS has solid skin 5, one collector 3, one stop module 4 made of thin rubber tube with one open end. Each gas cell 2 has conical shape. There is a refueling module 7, which is joined to the cellular module 1 at extra opening 8. The extra opening 8 has no stop module.

Stop module 4 represents (Figure 6) a special design element, which we have named "smart" rubber. It is a thin (about 1-mm thick) rubber film or tube, which covers the internal gas cells' apertures. In a case where outer wall 5 destruction causes gas to escape from one or several cells 2, this "smart" rubber 4 will nestle tightly into these open-ended apertures and block release of gas from the undamaged cells.

Gasar SCS with spherical radial cellular module 1 is shown in Figure 7. This SCS has solid skin 5, two collectors 3, one stop module 4 made of thin rubber tube. Each gas cell 2 has conical shape. There is a refueling module 7, which is joined to the cellular module 1 at extra opening 8. The extra opening 8 has no stop module.

Gasar SCS with parallel cellular module 1 is shown in Figure 8, left. This SCS has solid skin 5, one collector 3, one stop module 4 made of thin rubber membrane. Each gas cell 2 has ellipsoidal shape. There is a refueling module 7, which is joined to the cellular module 1 at extra opening 8. The extra opening 8 has no stop module.

Gasar SCS with parallel cellular module 1 is shown in Figure 8, right. This SCS has solid skin 5, one collector 3, one stop module 4 made of thin rubber membrane. Each gas cell 2 has irregular cylindrical shape. There is a refueling module 7, which is joined to the cellular module 1 at extra opening 8. The extra opening 8 has no stop module.

Gasar SCS with parallel cellular module 1 is shown in Figure 9, left. This SCS has solid skin 5, two collectors 3, two stop modules 4 made of thin rubber membrane. Each gas cell 2 has ellipsoidal shape. There is a refueling module 7, which is joined to the cellular module 1 at extra opening 8. The extra opening 8 has no stop module.

Gasar SCS with parallel cellular module 1 is shown in Figure 9, right. This SCS has solid skin 5, two collectors 3, two stop modules 4 made of thin rubber membrane. Each gas cell 2 has irregular cylindrical shape. There is a refueling module 7, which is joined to the cellular module 1 at extra opening 8. The extra opening 8 has no stop module.

TUBULAR SCS

Calculations show that tubular design of SCS has a very high capacity for storing hydrogen. Figure 10 shows the mass fraction of hydrogen stored as a function of the pressure in the tubular cells made of different materials.

A preferred embodiment of the tubular SCS is shown in Figure 11. Cellular module 1 comprises a package of tubes (cells 2) encased in a solid skin 5, a collector 3, and a stop module 4 made of thin rubber membrane. The cells 2 have thin walls 9, and relatively small diameter and various shapes in section, such as round, square or polygonal. The solid skin 5 is gas-proof and usually made of metal, such as steel, aluminum or high-strength alloys. For the purpose of improving the mechanical properties of the structure and thereby increasing SCS capacity, the solid skin 5 is preferably covered with an outer non-metallic continuous fiber winding wrap 10, which is preferably formed of carbon fiber, which has a very high modulus of elasticity and strength under tension as well as a very low density. Other suitable fibers include fiberglass, Zylon, Kevlars and Nomex. Calculations show that the winding of tubular cells with bore diameter of 6 mm and wall thickness of 0.1 mm with a layer of a carbon fiber with a thickness of 1 mm results in increasing SCS capacity by two and a half times. This design also allows reducing SCS cost by using cheap low carbon steel or aluminum for the gas-proof solid skin 5. Some rise in price due to the cost of carbon fiber is completely canceled by increasing SCS capacity.

A further advantage of the fiber winding wrapped structure described above is its improved degree of safety. Our experiments have shown that in cases where a tearing of the cells occurs, the fiber winding wrap 10 prevents the cells from breaking off in several pieces and

scattering in different directions with high velocity. Instead, the cells are broken off in two pieces, which remain fractionally bound oddments of the unaffected fiber.

Tubular SCS can be assembled with tubes having different length and diameter, and the length and the shape of the tubes is selected so, that the cellular module will have outside outlines and sizes relevant to the space for its arranging (automobile gas tank, plane wing etc.). One example is given on Figure 13.

SCS can contain a plurality of cell modules which are arranged in a cell module network providing a circulatory system in which each branching place has at least one collector (Figure 12).

REFERENCES:

1. Hydrogen in Semiconductors and Metals. Symposium Proceedings. Volume 513. April 13-17, 1998, San Francisco, CA, USA.
2. Hydrogen Materials Science & Chemistry of Metal Hydrides. Symposium Proceedings. 2-8 September, 1999, Ukraine.
3. Kozin L.F. Hydrogen Energetic is the Power of Future. Hydrogen Materials Science & Chemistry of Metal Hydrides. Symposium Proceedings. 2-8 September, 1999, Ukraine.
4. Barnes R.G. Hydrogen Storage Materials. 1988.
5. Hydrogen Energy System: Production and Utilization of Hydrogen and Future Aspects (NATO Asi Series. Series E, Applied Sciences, Vol 295) By Yuda Yurum (editor), September, 1995.
6. Howell D.G. Future of energy Gases, U.S. Geological Survey Professional Paper, #1570, 1993.
7. Proceedings of the 1999 U.S. DOE Hydrogen Program Review, May 1999.
8. Hoffinan P. The Forever Fuel: The Story of Hydrogen, 1997.
9. Chand T.K. Hydrogen fuel system for vehicle. U.S. Patent No. 4085709 (April 25,1978).
10. Jan-Mao C. Portable gas stove. U.S. Patent No. 59992408 (November 30,1999).
11. Wilson E.L. System for automatically selecting and discharging a pressurized cylinder. U.S. Patent No.48889152 (December 26, 1989).
12. Putruga F.G. Safety gas cylinder containment system. U.S. Patent No.4802515 (February 7, 1989).
13. Kirk K.G. Compressed gas mobile storage module and lightweight composite cylinders. U.S. Patent No.5385263 (January 31,1995).
14. Anderson M.D. Life saving device. U.S. Patent No.4810219 (March 7,1989).

15. Collier J.P. Seamless cylinder shell construction. U.S. Patent No.5485736 (January 23,1996).
16. Turner M.L. Cylinder pressure switch for automatic fire protection system. U.S. Patent No. 4953624 (September 4, 1990).
17. Edinger W.J. Self-contained containment for gas cylinder. U.S. Patent No.4478345 (October 23, 1984).
18. Bulow M. Method and vessel for the storage of gas. U.S. Patent No.6006797 (December 28, 1999).
19. Shapovalov V., Method for manufacturing porous articles U.S. Patent No. 5181549 (January 26, 1993).
20. Shapovalov V. Porous Metals. MRS Bulletin, April, #4,1994,p.24-29.

Summary

A safe cellular storage (SCS) for compressed hydrogen and other gases has a number of advantages over previously known designs such as convenience in operation, safety against explosive gas release at the global and local level, optional high speed extraction of hydrogen, high contents of hydrogen (about 5 % by weight), and low cost. The new SCS manufacturing technology arises from a very recent achievement in metallurgy and the science of materials. HHPS consists of a new technology for the production of high-strength porous metals and alloys. This technology generates three-dimensional cast products with several varieties of structure. The objective of this new SCS is to cast articles from stainless steel that are closely and evenly packed with longitudinally or radially oriented cylindrical pores 1-10 mm in diameter at a porosity level of 70-90 volume %. This innovative structure will isolate stored hydrogen into many small elements within the cylinder, so that upon an accident occurring, only damaged elements can leak, reducing the risk of massive explosion. This creative safe design of compressed gas cylinder is a break-through amongst hydrogen storage alternatives.

The SCS can be used to supply hydrogen for ground vehicles, fuel cells, portable hydrogen plasma generators and micro heat generators. Its use will considerably expand hydrogen utilization as an ecologically clean fuel through its use in fuel cells and by direct burning in internal combustion engines. In addition to the direct economic benefit from use of a cheaper storage design, there is an appreciable secondary benefit from the improvement of ecological conditions. Extensive use of this storage method might so increase the use of hydrogen fuel that the present condition of continuously increasing air pollution by hydrocarbon combustion products would reverse itself.

What is claimed is:

1. A method for storing compressed gas comprising introducing said gas at elevated pressure into a plurality of storage cells having a common gas distribution manifold whereby the pressure in the respective storage cells is maintained at substantially the same elevated value.
2. A method as defined in Claim 1 involving the further step of blocking the flow of gas between the common distribution manifold and a given one of said storage cells in response to a reduction of gas pressure in said given storage cell relative to the gas pressure in the common distribution manifold, such as may occur in the event of a leak in said given storage cell.
3. A system for storing compressed gas comprising a common manifold chamber for receiving gas to be stored, a plurality of storage cells, each of which has a first end open to said common manifold chamber for receiving gas from said chamber for storage in the respective storage cells and for removing stored gas therefrom, and a controllable outlet for said manifold chamber for introducing and removing gas from said system.
4. A system for storing compressed gas as defined in Claim 3, wherein the respective ends of each of said storage cells remote from said open first end is closed to confine stored gas in such storage cell.
5. A system for storing compressed gas as defined in Claim 3, wherein the respective ends of each of said storage cells remote from said open first end is open to a second common manifold chamber which is provided with a controllable outlet for receiving and removing gas from said system.
6. A storage system as defined in Claim 3, wherein the major portion of each of said storage cells is located outside of said manifold chamber, the passageways through the open ends

of said storage cells into said manifold chamber are provided with a closure for selectively blocking the passageway of any given storage cell to prevent gas from flowing from said manifold chamber into the respective storage cell when the gas pressure in the respective passageway falls below the pressure of gas in the manifold chamber, thereby isolating the respective cell from the manifold chamber and preventing loss of the system pressure and stored gas in the manifold chamber and remaining storage cells, which would otherwise occur in the event of a leak in the given storage cell that causes such lower pressure to occur in said given passageway.

7. A storage system as defined in Claim 4, wherein the major portion of each of said storage cells is located outside of said manifold chamber, the passageways through the open ends of said storage cells into said manifold chamber are provided with a closure for selectively blocking the passageway of any given storage cell to prevent gas from flowing from said manifold chamber into the respective storage cell when the gas pressure in the respective passageway falls below the pressure of gas in the manifold chamber, thereby isolating the respective cell from the manifold chamber and preventing loss of the system pressure and stored gas in the manifold chamber and remaining storage cells, which would otherwise occur in the event of a leak in the given storage cell that causes such lower pressure to occur in said given passageway.
8. A storage system as defined in Claim 5, wherein the major portion of each of said storage cells is located outside of both of said manifold chambers, the passageways through the open ends of said storage cells into the respective said manifold chambers are provided with a closure for selectively blocking the passageway of any given storage cell to prevent gas from flowing from the respective manifold chamber into the respective storage cell when the gas pressure in the respective passageway falls below the pressure of gas in the respective manifold chamber, thereby isolating the respective cell from the

respective manifold chamber and preventing loss of the system pressure and stored gas in the manifold chambers and remaining storage cells, which would otherwise occur in the event of a leak in the given storage cell that causes such lower pressure to occur in said given passageway.

9. A system for storing compressed gas as defined in Claim 6, wherein the passageways through the open ends of said tubes into said manifold chamber are terminated in a common plane within said chamber, and wherein the closure for selectively blocking the passageway of any given storage cell comprises a pliable rubber-like membrane disposed in said chamber in a plane adjacent to the plane of said terminated passageways.
10. A system for storing compressed gas as defined in Claim 7, wherein the passageways through the open ends of said tubes into said manifold chamber are terminated in a common plane within said chamber, and wherein the closure for selectively blocking the passageway of any given storage cell comprises a pliable rubber-like membrane disposed in said chamber in a plane adjacent to the plane of said terminated passageways.
11. A system for storing compressed gas as defined in Claim 8, wherein the passageways through the open ends of said tubes into the respective manifold chambers are terminated in a respective common plane within the respective chamber, and wherein the closure for selectively blocking the passageway of any given storage cell comprises a pliable rubber-like membrane disposed in the respective chamber in a plane adjacent to the respective plane of said terminated passageways.
12. A system for storing compressed gas as defined in Claim 6, wherein the manifold chamber comprises a central core of tubular configuration, the storage cells are disposed radially around said core with their respective ends adjacent said core terminating in passageways open to said chamber, and wherein the closure for selectively blocking the passageway of any given storage cell comprises a rubber-like membrane in the form of a

hollow sleeve positioned adjacent the passageways from said storage tubes, and wherein one end of said sleeve is closed and the opposite end thereof is open to a portion of said manifold chamber that is provided with an outlet for accessing said chamber for introduction or removal of gas from the system.

13. A system for storing compressed gas as defined in Claim 7, wherein the manifold chamber comprises a central core of tubular configuration, the storage cells are disposed radially around said core with their respective ends adjacent said core terminating in passageways open to said chamber, and wherein the closure for selectively blocking the passageway of any given storage cell comprises a rubber-like membrane in the form of a hollow sleeve positioned adjacent the passageways from said storage tubes, and wherein one end of said sleeve is closed and the opposite end thereof is open to a portion of said manifold chamber that is provided with an outlet for accessing said chamber for introduction or removal of gas from the system.
14. A system for storing compressed gas as defined in Claim 6, wherein a controllable inlet is provided for at least one of said cells, whereby gas can be supplied to said system through said inlet during the introduction of gas through the common manifold in order to reduce the tendency that the pressure of gas introduced through the common manifold will cause the closure to block the flow of such gas to the cells.
15. A system for storing compressed gas as defined in Claim 7, wherein a controllable inlet is provided for at least one of said cells, whereby gas can be supplied to said system through said inlet during the introduction of gas through the common manifold in order to reduce the tendency that the pressure of gas introduced through the common manifold will cause the closure to block the flow of such gas to the cells.
16. A system for storing compressed gas as defined in Claim 8, wherein a controllable inlet is provided for at least one of said cells whereby gas can be supplied to said system through

said inlet during the introduction of gas through either of the common manifolds in order to reduce the tendency that the pressure of gas introduced through such common manifold will cause the respective closure to block the flow of gas from such common manifold to the cells.

17. A system for storing compressed gas, as defined in Claim 3, wherein plurality of said storage cells are embodied in a cellular module.
18. A system for storing compressed gas, as defined in Claim 4, wherein plurality of said storage cells are embodied in a cellular module.
19. A system for storing compressed gas, as defined in Claim 5, wherein plurality of said storage cells are embodied in a cellular module.
20. A system for storing compressed gas, as defined in Claim 6, wherein plurality of said storage cells are embodied in a cellular module.
21. A system for storing compressed gas as defined in Claim 17, wherein the cellular module is comprised of porous material.
22. A system for storing compressed gas as defined in Claim 18, wherein the cellular module is comprised of porous material.
23. A system for storing compressed gas as defined in Claim 19, wherein the cellular module is comprised of porous material.
24. A system for storing compressed gas as defined in Claim 20, wherein the cellular module is comprised of porous material.
25. A system for storing compressed gas as defined in Claim 21, wherein the cellular module is comprised of gasar material.
26. A system for storing compressed gas as defined in Claim 22, wherein the cellular module is comprised of gasar material

27. A system for storing compressed gas as defined in Claim 23, wherein the cellular module is comprised of gasar material
28. A system for storing compressed gas as defined in Claim 24, wherein the cellular module is comprised of gasar material
29. A system for storing compressed gas as defined in Claim 6, wherein the storage cells are comprised of cellular module formed of gasar material
30. A system for storing compressed gas as defined in Claim 17, wherein the cellular module is formed of monolithic plastic material.
31. A system for storing compressed gas as defined in Claim 18, wherein the cellular module is formed of monolithic plastic material.
32. A system for storing compressed gas as defined in Claim 19, wherein the cellular module is formed of monolithic plastic material.
33. A system for storing compressed gas as defined in Claim 20, wherein the cellular module is formed of monolithic plastic material.
34. A system as defined in Claim 17, wherein the cellular module is made of powder material consolidated by methods of powder metallurgy.
35. A system as defined in Claim 18, wherein the cellular module is made of powder material consolidated by methods of powder metallurgy.
36. A system as defined in Claim 19, wherein the cellular module is made of powder material consolidated by methods of powder metallurgy.
37. A system as defined in Claim 20, wherein the cellular module is made of powder material consolidated by methods of powder metallurgy.
38. A system for storing compressed gas as defined in Claim 3, wherein the storage cells are of cylindrical configuration.

39. A system for storing compressed gas as defined in Claim 17, wherein the storage cells are of cylindrical configuration.
40. A system for storing compressed gas as defined in Claim 18, wherein the storage cells are of cylindrical configuration.
41. A system for storing compressed gas as defined in Claim 19, wherein the storage cells are of cylindrical configuration.
42. A system for storing compressed gas as defined in Claim 20, wherein the storage cells are of cylindrical configuration.
43. A system for storing compressed gas as defined in Claim 38, wherein the cells have a diameter in the range of 10 microns to 20 millimeters.
44. A system for storing compressed gas as defined in Claim 39, wherein the cells have a diameter in the range of 10 microns to 20 millimeters.
45. A system for storing compressed gas as defined in Claim 40, wherein the cells have a diameter in the range of 10 microns to 20 millimeters.
46. A system for storing compressed gas as defined in Claim 41, wherein the cells have a diameter in the range of 10 microns to 20 millimeters.
47. A system for storing compressed gas as defined in Claim 42, wherein the cells have a diameter in the range of 10 microns to 20 millimeters.
48. A system for storing compressed gas as defined in Claim 3, wherein the storage cells are encased in a gas-proof solid skin covered with an outer non-metallic continuous fiber winding wrap.
49. A system for storing compressed gas as defined in Claim 6, wherein the storage cells are encased in a gas-proof solid skin covered with an outer non-metallic continuous fiber winding wrap.

50. A system for storing compressed gas as defined in Claim 17, wherein said cellular module is encased in a gas-proof solid skin covered with an outer non-metallic continuous fiber winding wrap.
51. A system for storing compressed gas as defined in Claim 20, wherein said cellular module is encased in a gas-proof solid skin covered with an outer non-metallic continuous fiber winding wrap.
52. A system for storing compressed gas as defined in Claim 48, wherein said fiber winding wrap is formed of carbon fiber.
53. A system for storing compressed gas as defined in Claim 49, wherein said fiber winding wrap is formed of carbon fiber.
54. A system for storing compressed gas as defined in Claim 50, wherein said fiber winding wrap is formed of carbon fiber.
55. A system for storing compressed gas as defined in Claim 51, wherein said fiber winding wrap is formed of carbon fiber.

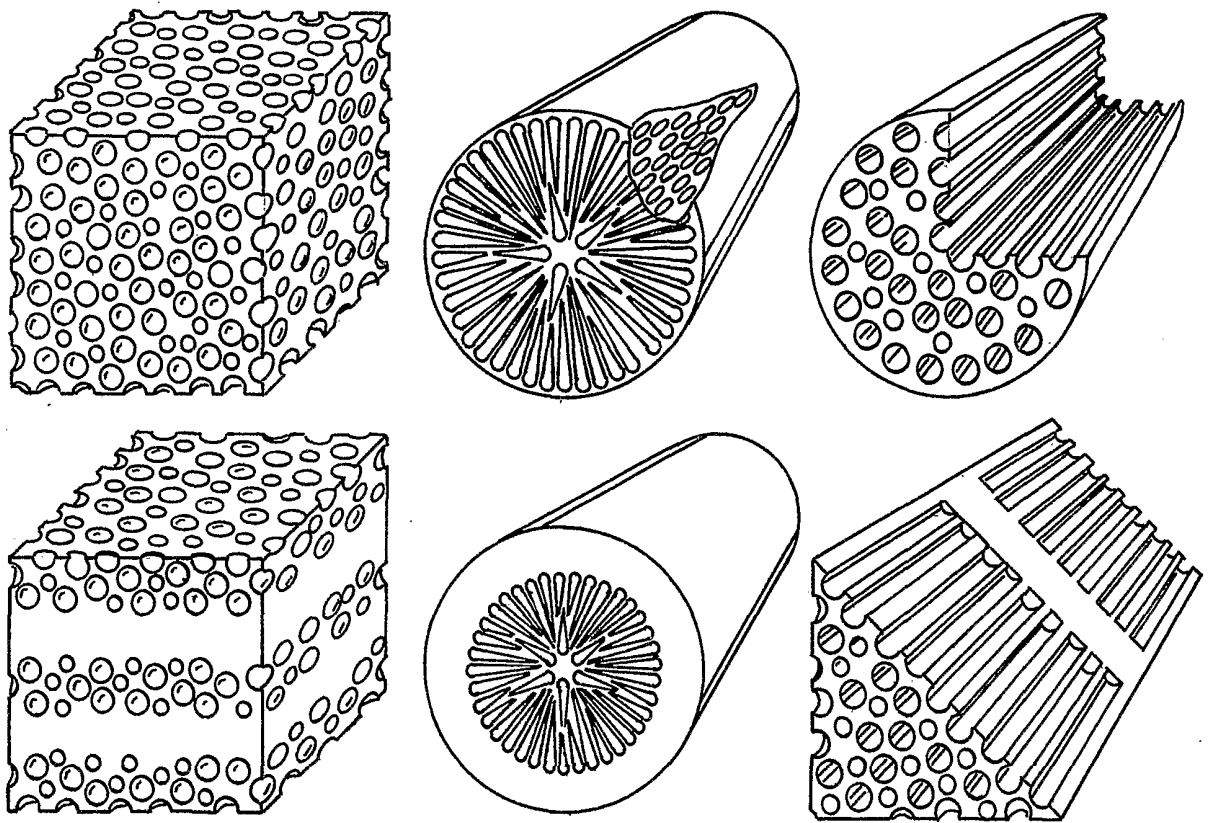

FIG. 1

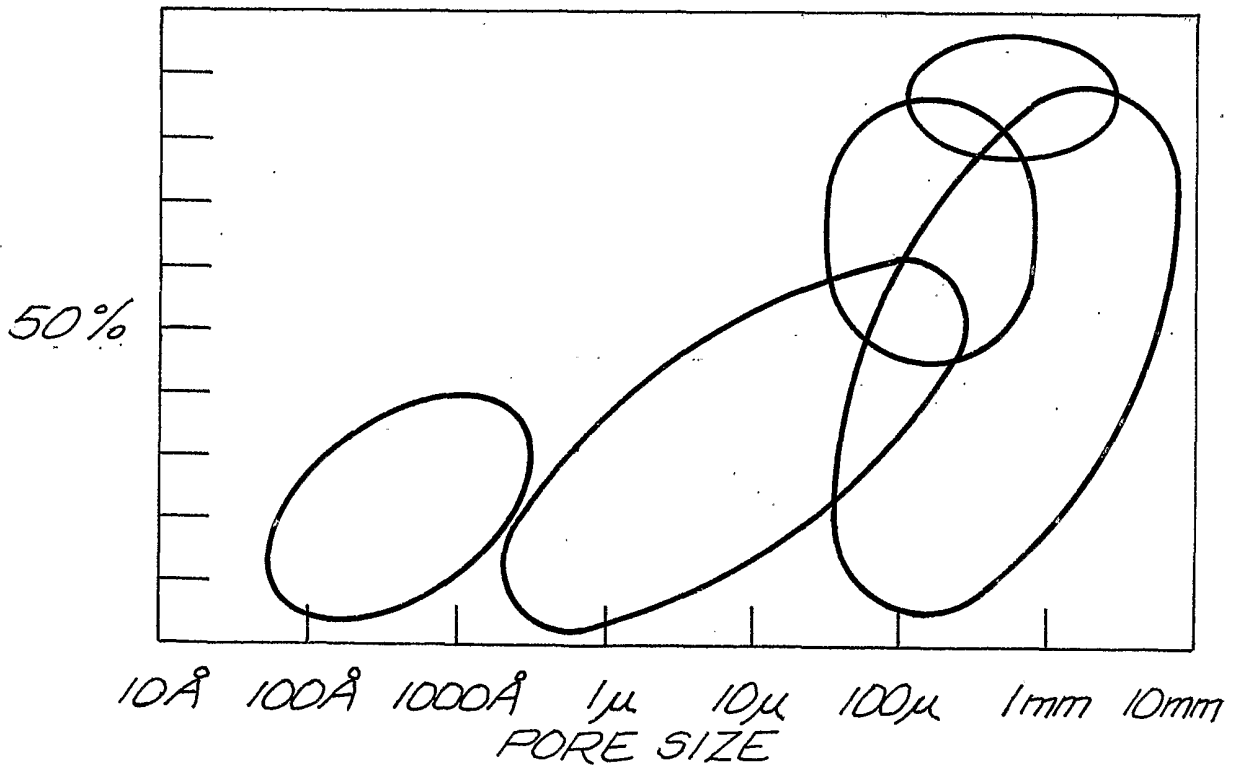

FIG. 2

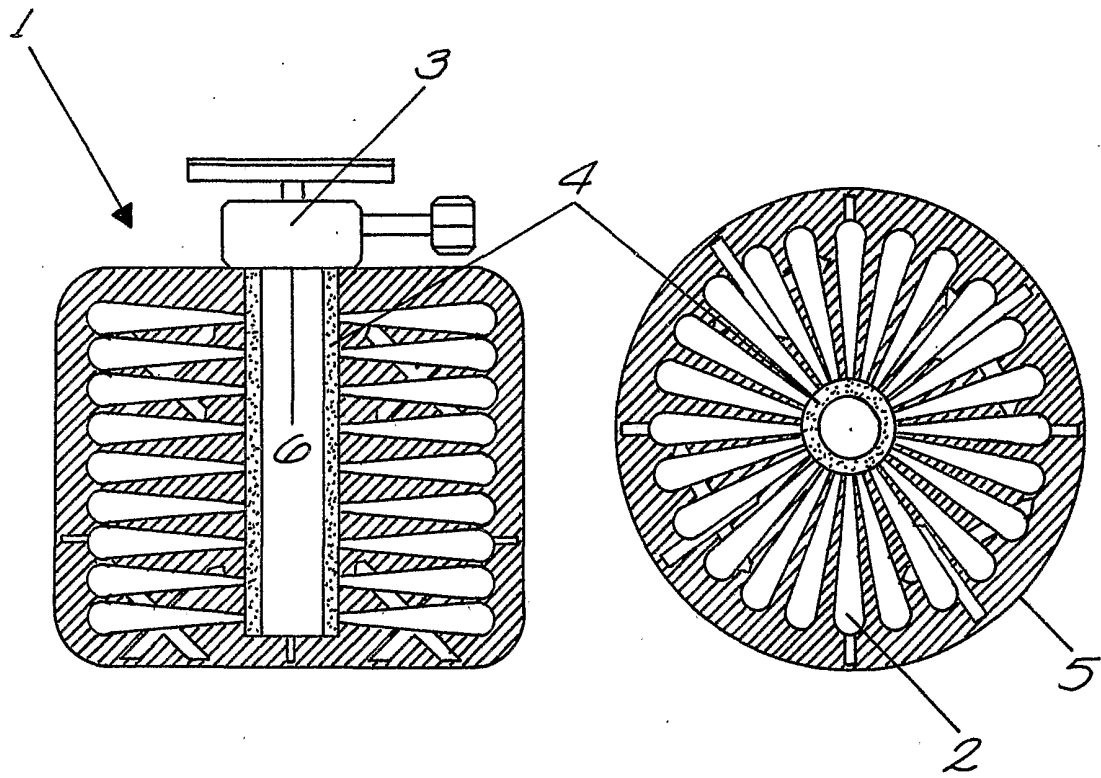

FIG. 3

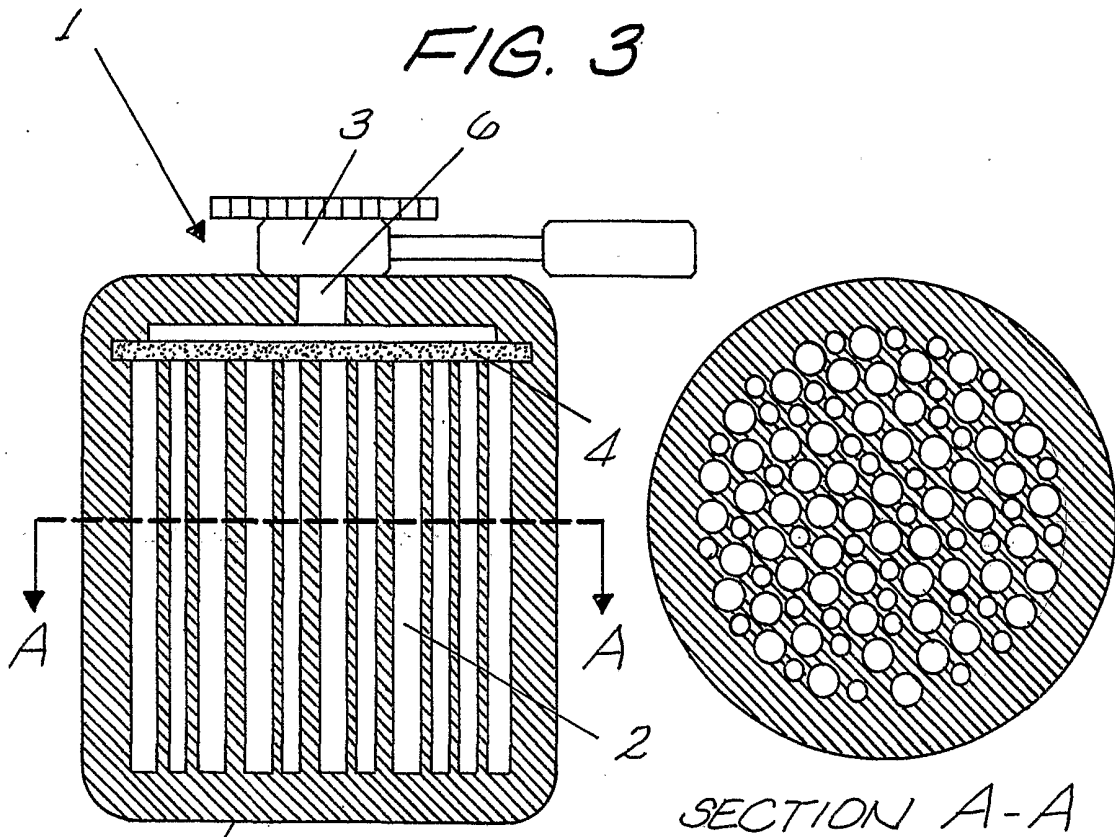
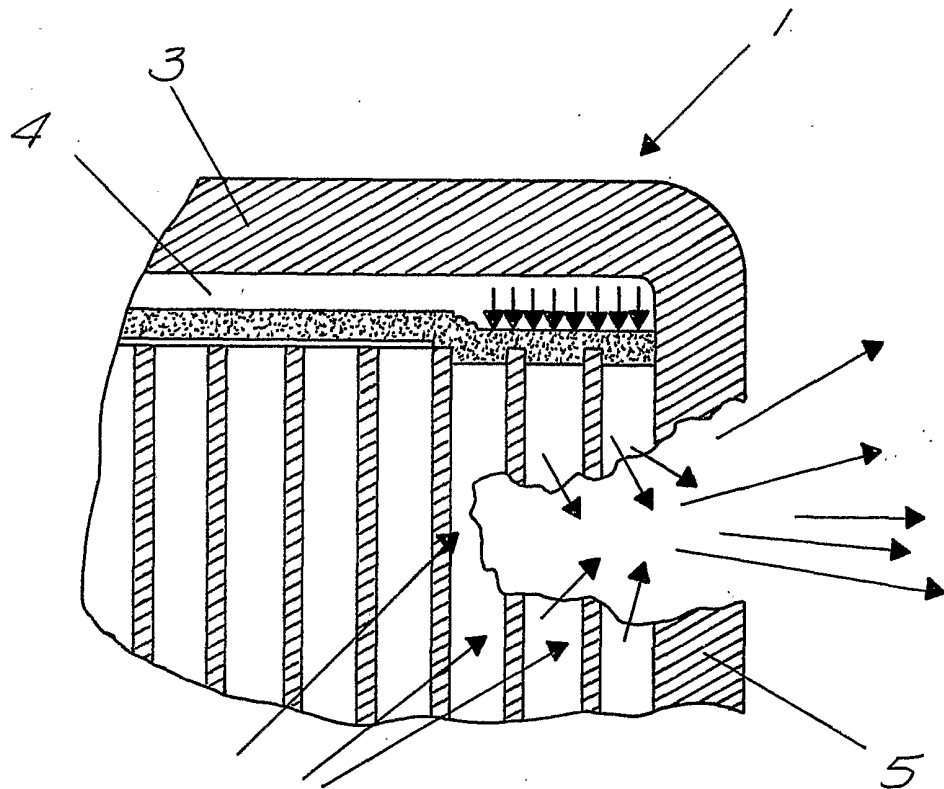
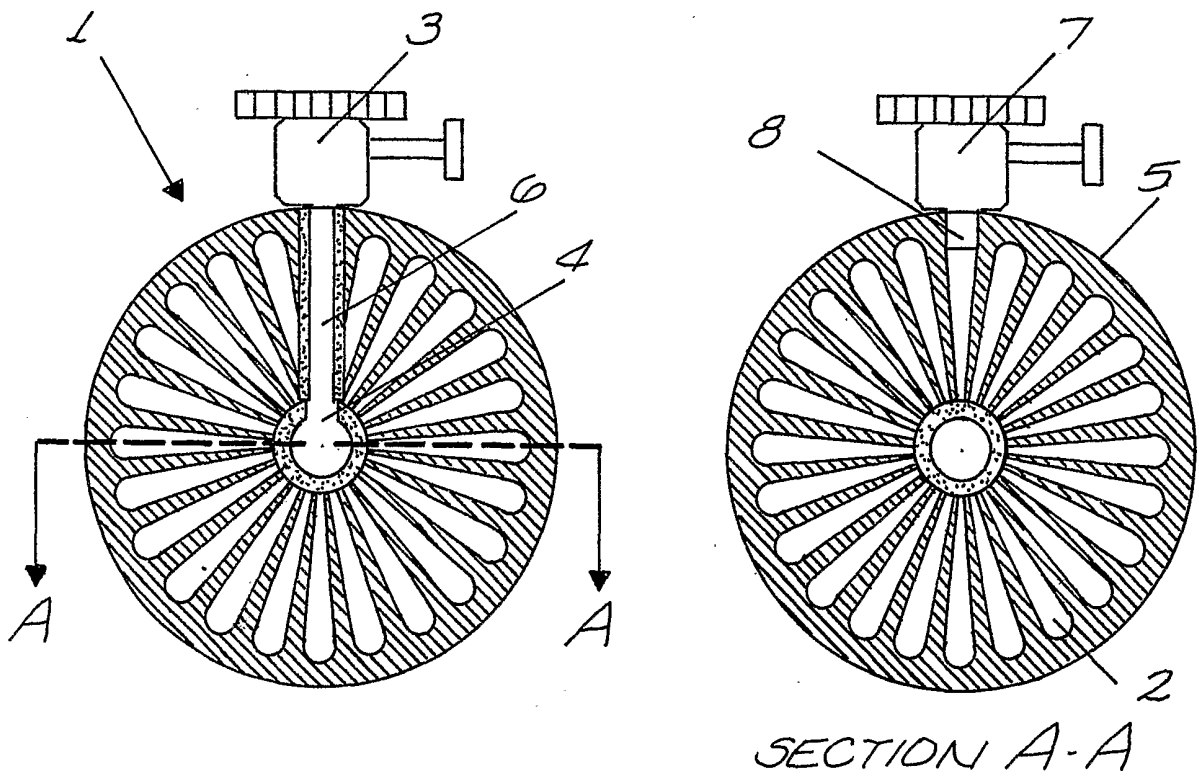

FIG. 4



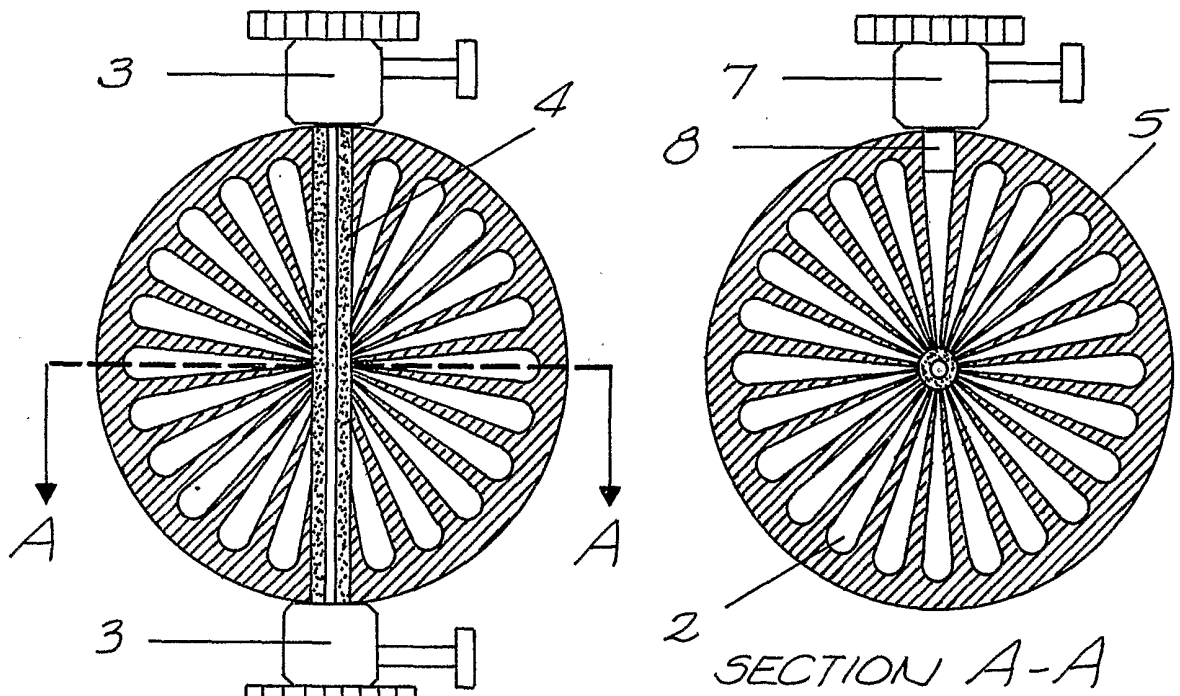

FIG. 7

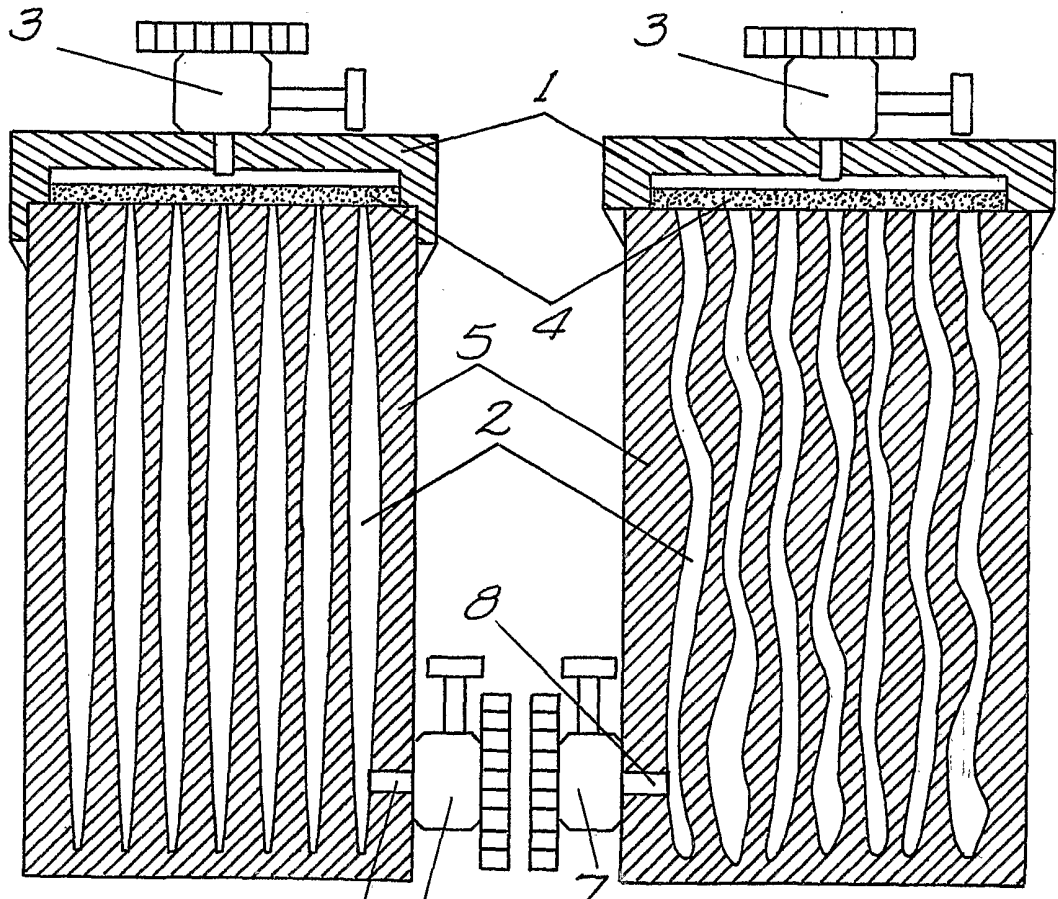

FIG. 8

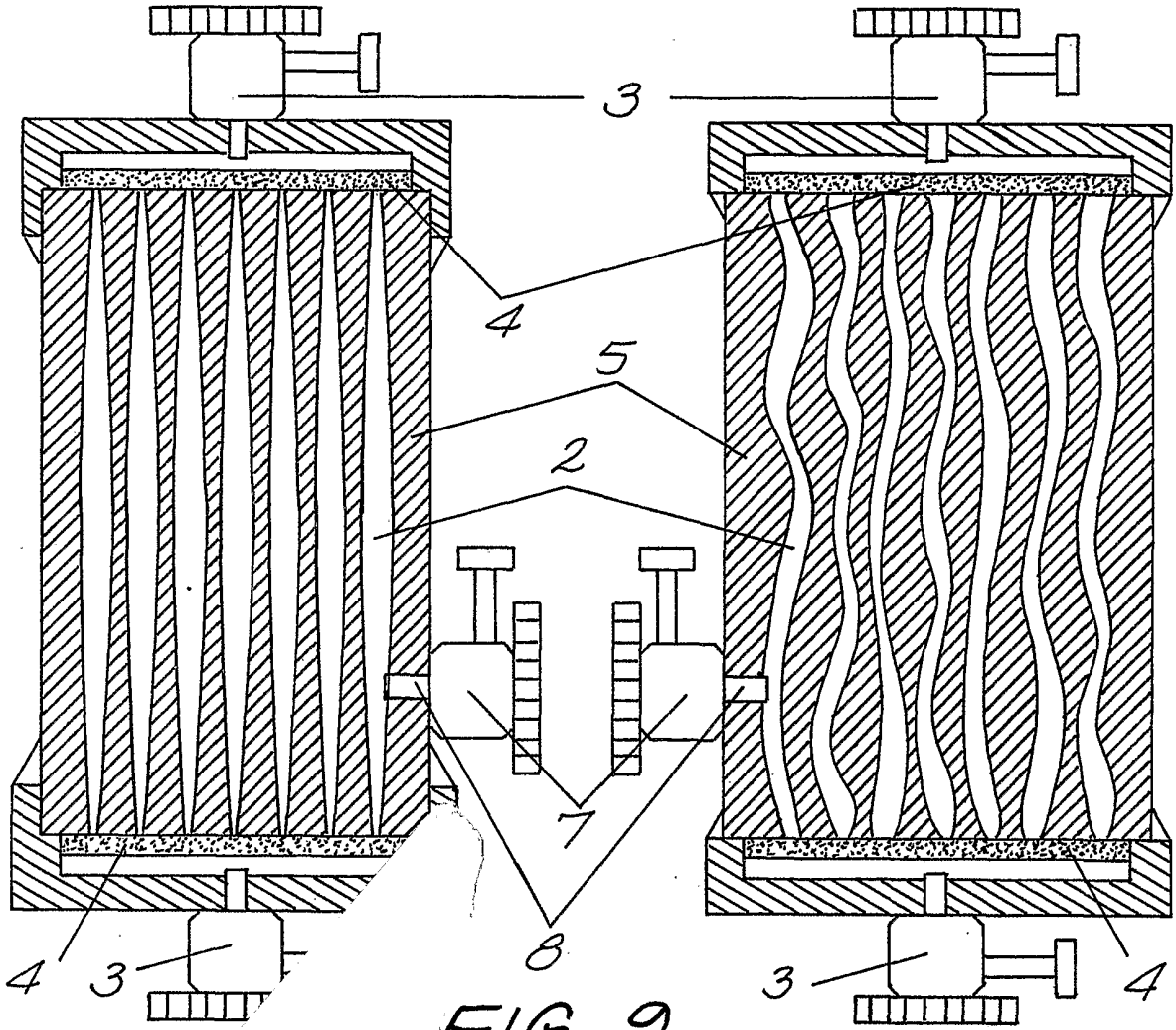

FIG. 9

DROGEN

18.

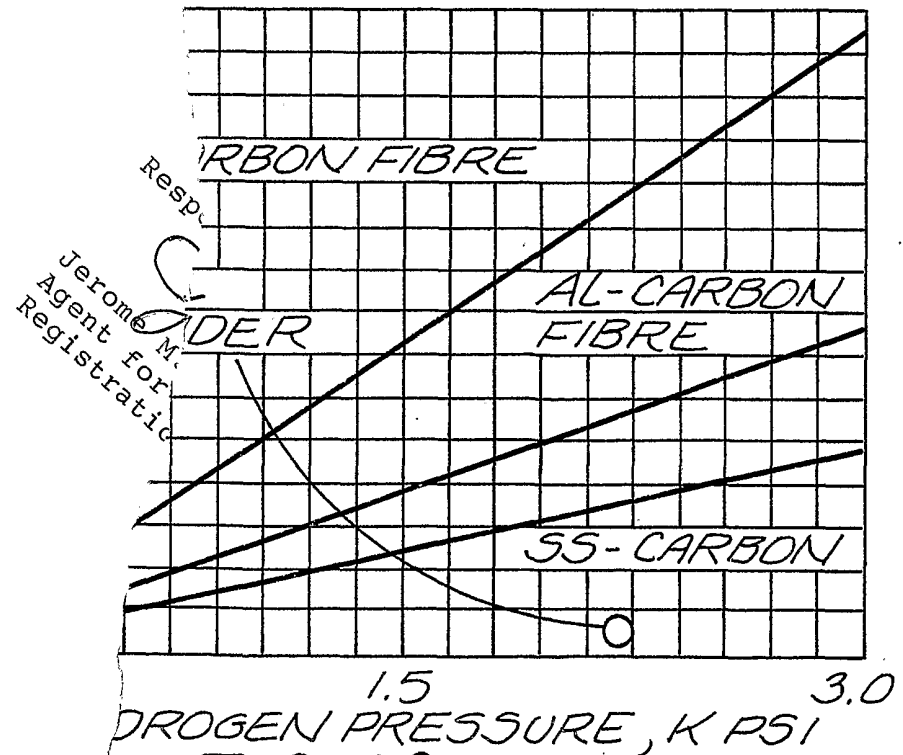

FIG. 10

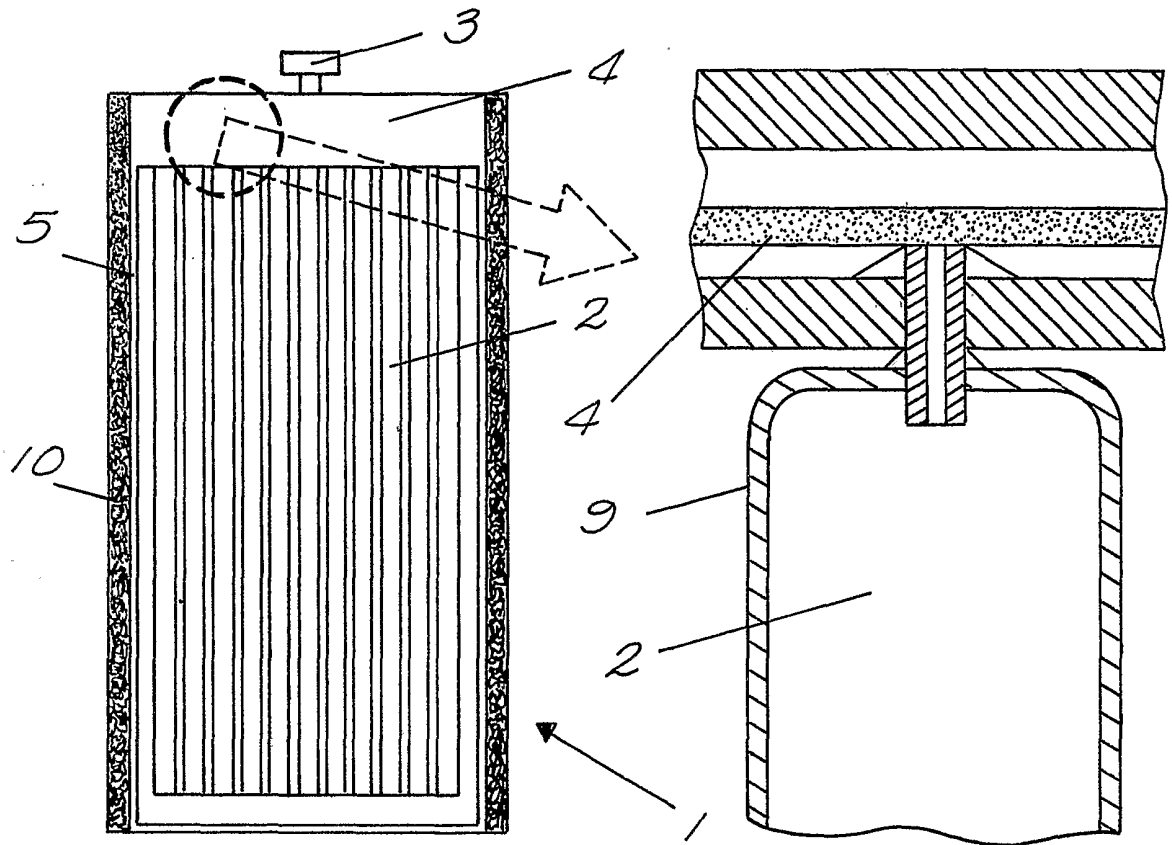

FIG. 11

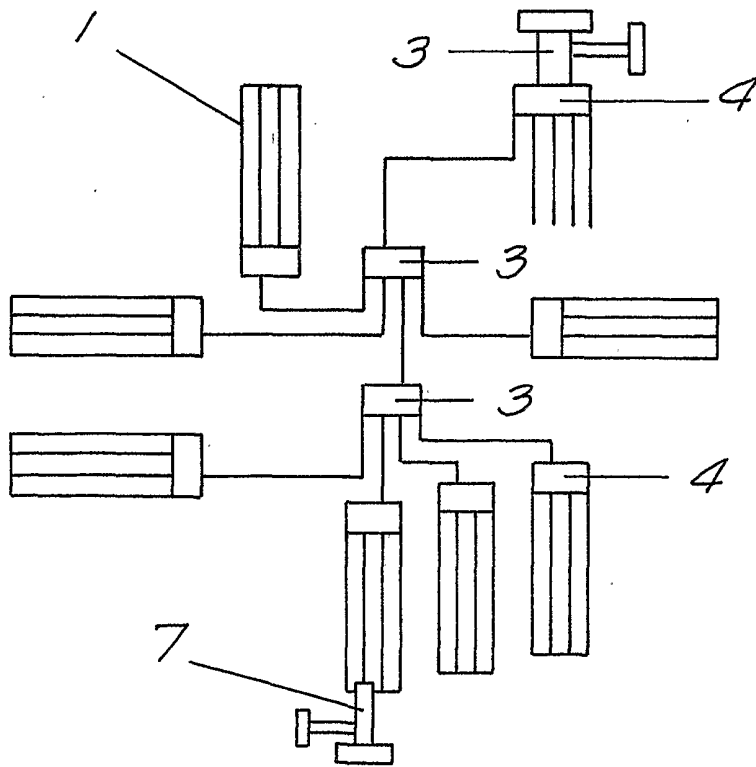

FIG. 12

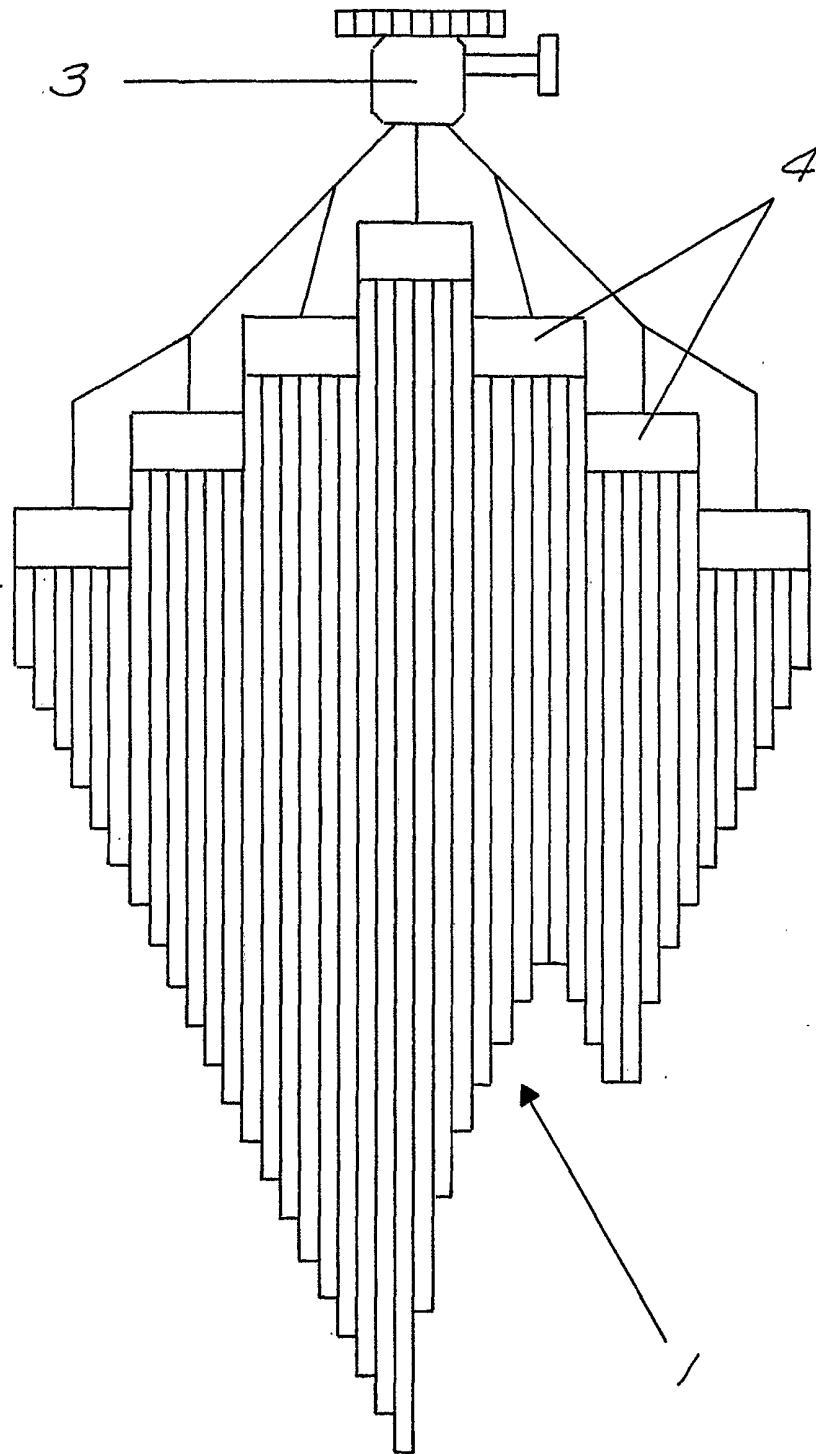

FIG. 13

INTERNATIONAL SEARCH REPORT

International application No.

PCT/US01/27422

A. CLASSIFICATION OF SUBJECT MATTER
 IPC(7) : B65B 1/04
 US CL : 141/4,237
 According to International Patent Classification (IPC) or to both national classification and IPC

B. FIELDS SEARCHED
 Minimum documentation searched (classification system followed by classification symbols)
 U.S. : 141/2,4,18,237-245

Documentation searched other than minimum documentation to the extent that such documents are included in the fields searched
 NONE

Electronic data base consulted during the international search (name of data base and, where practicable, search terms used)
 EAST

C. DOCUMENTS CONSIDERED TO BE RELEVANT

Category *	Citation of document, with indication, where appropriate, of the relevant passages	Relevant to claim No.
X	US 5,954,099 A (PRINCIOTTA et al.) 21 September 1999 (21.09.1999), see entire document.	1
X	US 4,153,083 A (IMLER et al.) 08 May 1979 (08.05.1979), see entire document.	1

Further documents are listed in the continuation of Box C. See patent family annex.

* Special categories of cited documents:	Symbol
"A" document defining the general state of the art which is not considered to be of particular relevance	"T" later document published after the international filing date or priority date and not in conflict with the application but cited to understand the principle or theory underlying the invention
"E" earlier application or patent published on or after the international filing date	"X" document of particular relevance; the claimed invention cannot be considered novel or cannot be considered to involve an inventive step when the document is taken alone
"L" document which may throw doubts on priority claim(s) or which is cited to establish the publication date of another citation or other special reason (as specified)	"Y" document of particular relevance; the claimed invention cannot be considered to involve an inventive step when the document is combined with one or more other such documents, such combination being obvious to a person skilled in the art
"O" document referring to an oral disclosure, use, exhibition or other means	"&" document member of the same patent family
"P" document published prior to the international filing date but later than the priority date claimed	

Date of the actual completion of the international search 09 November 2001 (09.11.2001)	Date of mailing of the international search report 14 DEC 2001
--------------------------------------------------------------------------------------------	--------------------------------------------------------------------------

Name and mailing address of the ISA/US Commissioner of Patents and Trademarks Box PCT Washington, D.C. 20231 Facsimile No. (703)305-3230	Authorized officer <i>A. Hurley for</i> Steven O. Douglas Telephone No. 703-308-0861
------------------------------------------------------------------------------------------------------------------------------------------------------	--------------------------------------------------------------------------------------------