



(86) Date de dépôt PCT/PCT Filing Date: 2004/04/01  
(87) Date publication PCT/PCT Publication Date: 2004/10/21  
(85) Entrée phase nationale/National Entry: 2005/09/23  
(86) N° demande PCT/PCT Application No.: GB 2004/001396  
(87) N° publication PCT/PCT Publication No.: 2004/089350  
(30) Priorité/Priority: 2003/04/05 (0307918.3) GB

(51) Cl.Int.<sup>7</sup>/Int.Cl.<sup>7</sup> A61K 31/00, A61K 31/554, A61P 1/10  
(71) Demandeur/Applicant:  
ASTRAZENECA AB, SE  
(72) Inventeurs/Inventors:  
ABRAHAMSSON, HASSE ROLAND, SE;  
GILLBERG, PER-GORAN, SE  
(74) Agent: FETHERSTONHAUGH & CO.

(54) Titre : UTILISATION D'UN INHIBITEUR D'IBAT DANS LE TRAITEMENT OU LA PROPHYLAXIE DE LA  
CONSTIPATION

(54) Title: USE OF AN IBAT INHIBITOR FOR THE TREATMENT OF PROPHYLAXIS OF CONSTIPATION

(57) **Abrégé/Abstract:**

The use of an IBAT inhibitor in the treatment and/or prophylaxis of constipation, in a warm-blooded animal, such as man is described.



(12) INTERNATIONAL APPLICATION PUBLISHED UNDER THE PATENT COOPERATION TREATY (PCT)

(19) World Intellectual Property  
Organization  
International Bureau



(43) International Publication Date  
21 October 2004 (21.10.2004)

PCT

(10) International Publication Number  
**WO 2004/089350 A1**

- (51) International Patent Classification<sup>7</sup>: **A61K 31/00**, 31/554, A61P 1/10
- (74) Agent: **ASTRAZENECA**; Global Intellectual Property, P.O. Box 272, Mereside, Macclesfield, Cheshire SK10 4GR (GB).
- (21) International Application Number: PCT/GB2004/001396
- (81) Designated States (*unless otherwise indicated, for every kind of national protection available*): AE, AG, AL, AM, AT, AU, AZ, BA, BB, BG, BR, BW, BY, BZ, CA, CH, CN, CO, CR, CU, CZ, DE, DK, DM, DZ, EC, EE, EG, ES, FI, GB, GD, GE, GH, GM, HR, HU, ID, IL, IN, IS, JP, KE, KG, KP, KR, KZ, LC, LK, LR, LS, LT, LU, LV, MA, MD, MG, MK, MN, MW, MX, MZ, NA, NI, NO, NZ, OM, PG, PH, PL, PT, RO, RU, SC, SD, SE, SG, SK, SL, SY, TJ, TM, TN, TR, TT, TZ, UA, UG, US, UZ, VC, VN, YU, ZA, ZM, ZW.
- (22) International Filing Date: 1 April 2004 (01.04.2004)
- (25) Filing Language: English
- (26) Publication Language: English
- (30) Priority Data: 0307918.3 5 April 2003 (05.04.2003) GB
- (84) Designated States (*unless otherwise indicated, for every kind of regional protection available*): ARIPO (BW, GH, GM, KE, LS, MW, MZ, SD, SL, SZ, TZ, UG, ZM, ZW), Eurasian (AM, AZ, BY, KG, KZ, MD, RU, TJ, TM), European (AT, BE, BG, CH, CY, CZ, DE, DK, EE, ES, FI, FR, GB, GR, HU, IE, IT, LU, MC, NL, PL, PT, RO, SE, SI, SK, TR), OAPI (BF, BJ, CF, CG, CI, CM, GA, GN, GQ, GW, ML, MR, NE, SN, TD, TG).
- (71) Applicant (*for all designated States except MG, US*): **ASTRAZENECA AB** [SE/SE]; SE-151 85 Sodertalje (SE).
- (71) Applicant (*for MG only*): **ASTRAZENECA UK LIMITED** [GB/GB]; 15 Stanhope Gate, Greater London, London W1K 1LN (GB).
- (72) Inventors; and
- (75) Inventors/Applicants (*for US only*): **ABRAHAMSSON, Hasse, Roland** [SE/SE]; Sahlgrenska University Hospital, Department of Internal Medicine, SE-413 45 Goteborg (SE). **GILLBERG, Per-Goran** [SE/SE]; AstraZeneca R & D Molndal, SE-431 83 Molndal (SE).
- Published:**  
— with international search report
- For two-letter codes and other abbreviations, refer to the "Guidance Notes on Codes and Abbreviations" appearing at the beginning of each regular issue of the PCT Gazette.*



**WO 2004/089350 A1**

(54) Title: USE OF AN IBAT INHIBITOR FOR THE TREATMENT OF PROPHYLAXIS OF CONSTIPATION

(57) Abstract: The use of an IBAT inhibitor in the treatment and/or prophylaxis of constipation, in a warm-blooded animal, such as man is described.

## USE OF AN IBAT INHIBITOR FOR THE TREATMENT OR PROPHYLAXIS OF CONSTIPATION

The present invention relates to a novel treatment and / or prophylaxis of functional constipation and constipation predominant Irritable Bowel Syndrome (C-IBS). More specifically the invention relates to the use of an ileal bile acid transport (IBAT) inhibitor in the treatment and / or prophylaxis of these disorders and pharmaceutical compositions comprising said IBAT inhibitor for use in the treatment and / or prophylaxis of these disorders.

Constipation and / or its associated symptoms, afflicts many people in the Western World and the prevalence is greatest amongst children and the elderly. Constipation can occur in up to 20% of a population depending on the demographic factors, sampling and definitions used. In a study of approximately 2000 people in five different European countries (Gastroenterology 118:A720, 2000), between 6% and 23% of subjects said that they had experienced constipation during the past 12 months, approximately 20% of the subjects had taken a laxative within that period and at least 10% experienced difficulty in defecation at least once a month. In the 1991 National Health Interview Survey, about 4.5 million people in the United States say they are constipated most or all of the time. Those reporting constipation most often are women, children, and adults age 65 and over. Pregnant women also complain of constipation, and it is a common problem following childbirth or surgery. Females constitute the largest group of patients with constipation and the problem increases with age in most studies.

Surveys of Western populations have revealed IBS in 15-20% of adolescents and adults, with a higher prevalence in women (the prevalence is variable in other populations). 30 to 35 % of IBS patients have constipation as a major symptom together with abdominal pain and / or discomfort (C-IBS).

Causes of constipation are varied and include general factors such as sex, age, nationality, diet and exercise; colonic anatomy and function such as luminal contents, absorption of water and sodium, diameter and length of the colon and colonic motor function; defecatory function such as normal defunction, failure of relaxation of the anal sphincter complex, ineffective straining, diminished rectal sensation and size and consistency of stool; disorders of the anorectum and pelvic floor; and psychological and behavioural factors. Some medical conditions can cause or result in constipation, for example neurological disorders such as multiple sclerosis, Parkinson's disease; chronic idiopathic intestinal pseudo-

obstruction; stroke and spinal cord injuries; metabolic and endocrine conditions such as diabetes, underactive or overactive thyroid gland and uremia; and systemic disorders such as amyloidosis, lupus and scleroderma. Some drug treatments including analgesics such as opiates, anticholinergics, such as antispasmodics, tricyclic antidepressants, phenothiazines and antimuscarinics; serotonin receptor antagonists; and calcium/aluminium containing antacids can also cause constipation.

Functional constipation comprises a group of functional disorders which present as persistent difficult, infrequent or seemingly incomplete defecation. It is more common in women and is usually found to increase with age.

IBS comprises a group of functional bowel disorders in which abdominal discomfort or pain is associated with defecation or a change in bowel habit, and with features of disordered defecation. IBS has a chronic relapsing course and overlaps with other functional gastrointestinal disorders. It accounts for high direct medical expenses and indirect costs, including absenteeism from work.

Symptoms associated with constipation include infrequent stools, no urge to pass stools, stools that are difficult to pass, ineffective straining, need to digitate, sense of incomplete evacuation, anal or perineal pain, prolapse at the anus and soiling of clothes. Bloating (distension), discomfort and pain are also symptoms of constipation. When pain is a symptom of constipation it can be caused by various factors including strong contractions and distension of the intestinal tract. There also, seems to be a correlation between high amplitude propagating contractions and pain in constipated patients (Dig Dis Sci 36, 827-862, 1991). Antispasmodics are sometimes used to alleviate this pain because they are believed to reduce strong contractions associated with pain (Pharmacol. Ther., 80, 49-98, 1998). The antimuscarinic compounds atropine (Digestive Diseases & Sciences 40 (6):1381-7, 1995) and zamifenacin (Aliment. Pharmacol. Ther., 11, 561-8, 1997) have both been found to reduce constipation pain.

Current treatment regimes for constipation itself include: (i) dietary fibre; (ii) other bulk laxatives such as psyllium, methylcellulose, and calcium polycarbophil; (iii) polyethylene glycol solution (PEG); (iv) stimulant laxatives such as bisacodyl, sodium picosulphate, or sennosides; (v) 5-hydroxytryptamine 4 (5-HT<sub>4</sub>) agonists such as prucalopride (vi) enemas and suppositories; and (vii) surgery; but the therapeutic results of these treatments are often disappointing and they can result in unpleasant side effects. For instance, an increase in dietary fibre often doesn't relieve the constipation and in some cases actually worsens the

symptoms, for example by aggravating the sense of distension (Gut 27:41, 1986). The other bulk laxatives often fail for the same reason and in general bulk laxatives are only suitable for long term use, they are not appropriate for the rapid relief of temporary constipation. The use of PEG solutions can be effective, but generally involve drinking large volumes of fluid (*circa* 5 one litre per day for up to three days) which, as well as being unpleasant, is clearly unsuitable for patients, e.g. children, who have difficulty in drinking such amounts. Stimulant laxative treatments have many documented side effects and can result in laxative dependence and abuse. The 5-HT<sub>4</sub> agonists, as well as having the desired effect in the colon, can affect gastric emptying and the small bowel (Clinical Pharmacology & Therapeutics, 67:2 (PII-33), 2000). 10 resulting in diarrhoea. Enemas and suppositories can result in serious damage to the rectal mucosa, furthermore if large volumes are used in an enema then serious water intoxication can occur if the enema is retained. Surgery, for example a colectomy, can be effective, but has also been documented to give unsatisfactory results, for example further surgery might be needed, the constipation may persist or diarrhoea with incontinence may develop.

15 The laxative effect of bile acids has also been documented (Br J Surg 1979; 66; 776-9; Gut 1975, 16, 894-902; and Gut 1973, 14, 348-353) and although it is feasible to administer bile acids orally for treatment of constipation (Myo Clinic Proceedings, 1973, 48, 356) they have an unwanted effect on the small bowel where they increase the motility - which potentially results in side effects like reduced absorption of nutrients.

20 There is clearly a need to identify additional treatments for constipation and preferably more effective treatments or ones with reduced side effects.

Many IBAT inhibitors have been disclosed in the literature (see below) and they are identified as being useful in the treatment of dyslipidaemic conditions and disorders, for example hyperlipidaemia, and as useful in the prevention and treatment of different 25 cardiovascular clinical conditions, for example atherosclerosis. The rationale for treatment of a dyslipidaemic condition with an IBAT inhibitor is that by increasing bile acid and cholesterol excretion, a favourable negative cholesterol balance and an improvement to the atherogenic lipoprotein profile should be achieved.

The use of an IBAT inhibitor to treat gastrointestinal (GI) disorders has not been 30 suggested or contemplated in the literature. In fact some reports suggest that therapeutic treatment of dyslipidaemia with an IBAT inhibitor might actually cause GI problems, for example Glaxo SmithKline published a clinical study (abstract, DALM September 2001) showing GI side effects (diarrhoea and abdominal cramping) during IBAT inhibition in man.

- 4 -

The present invention concerns a novel treatment and / or prophylaxis of constipation with an IBAT inhibitor. This treatment and / or prophylaxis results in the delivery of bile acids into the colon where they act as endogenous laxatives. Local delivery to the colon avoids the side effects (detailed above) of orally delivering bile acids since they will not affect parts of the GI tract before the colon. Avoiding affecting the GI tract above the colon, by administering an IBAT inhibitor would also be expected to give advantages over treatments with existing pharmaceuticals such as 5-HT4 agonists. In addition, some IBAT inhibitors have very low bioavailability (<2%), in this case the systemic exposure is low resulting in a reduced risk of side effects. Furthermore, IBAT inhibitors could alleviate the pain symptoms by a similar secondary mechanism to antimuscarinic drugs. This alleviation of pain would arise because IBAT inhibitors would increase motility and the amount of water in the content of the lower bowel. This in turn would lead to a softer content that is easier to move and does not accumulate, therefore there would be less distension of the intestine wall and it is well known that distension of the intestinal tract generates pain. Furthermore, fewer high amplitude propagating contractions are needed to move the content of the intestine, when the bowel content are soft, and again less pain is experienced.

Accordingly the present invention comprises the use of an IBAT inhibitor, or a pharmaceutically acceptable salt, solvate, solvate of such a salt or a prodrug thereof, in the treatment and / or prophylaxis of constipation.

Herein where the term "constipation" is used, it is to be understood that this term, unless otherwise qualified, relates to functional constipation and C-IBS. In one aspect of the invention "constipation" relates to functional constipation. In another aspect of the invention "constipation" relates to C-IBS.

One aspect of the invention relates to the treatment of constipation. Another aspect relates to the prophylaxis of constipation. A third aspect relates to the treatment and prophylaxis of constipation.

In one aspect of the invention, where the treatment of constipation is referred to and the constipation relates to C-IBS it is to be understood that this includes alternating (constipation-diarrohea) irritable bowel syndrome.

Also herein, where the terms "functional constipation" and "C-IBS" are used, it is to be understood that they are defined according to the "Rome 2 Criteria" (Gut 45 (Suppl 2): 43, 1999, II43-II47).

- 5 -

In the literature IBAT inhibitors are often referred to by different names. It is to be understood that where IBAT inhibitors are referred to herein, this term also encompasses compounds known in the literature as:

- i) ileal apical sodium co-dependent bile acid transporter (ASBT) inhibitors;
  - 5 ii) bile acid transporter (BAT) inhibitors;
  - iii) ileal sodium/bile acid cotransporter system inhibitors;
  - iv) apical sodium-bile acid cotransporter inhibitors;
  - v) ileal sodium-dependent bile acid transport inhibitors;
  - vi) bile acid reabsorption (BARI's) inhibitors; and
  - 10 vii) sodium bile acid transporter (SBAT) inhibitors;
- where they act by inhibition of IBAT.

Suitable compounds possessing IBAT inhibitory activity have been described, see for instance the compounds described in WO 93/16055, WO 94/18183, WO 94/18184, WO 94/24087, WO 96/05188, WO 96/08484, WO 96/16051, WO 97/33882, WO98/07749, WO 15 98/38182, WO 98/40375, WO 98/56757, WO 99/32478, WO 99/35135, WO 99/64409, WO 99/64410, WO 00/01687, WO 00/20392, WO 00/20393, WO 00/20410, WO 00/20437, WO 01/34570, WO 00/35889, WO 00/47568, WO 00/61568, WO 01/68637, WO 01/68096, WO 02/08211, WO 00/38725, WO 00/38726, WO 00/38727, WO 00/38728, WO 00/38729, DE 19825804, JP 10072371, US 5070103, EP 251 315, EP 417 725, EP 489 423, EP 549 967, EP 20 573 848, EP 624 593, EP 624 594, EP 624 595, EP 869 121, EP 864 582, and EP 1 070 703, and the contents of these patent applications, particularly the compounds described in claim 1 and the named examples, are incorporated herein by reference.

Particular classes of IBAT inhibitors suitable for use in the present invention are benzothiepinines. Other suitable classes of IBAT inhibitors are any one of the 1,2- 25 benzothiazepines, 1,4-benzothiazepines and 1,5-benzothiazepines. A further suitable class of IBAT inhibitors is the 1,2,5-benzothiadiazepines.

One particular suitable compound possessing IBAT inhibitory activity is (3*R*,5*R*)-3-butyl-3-ethyl-1,1-dioxido-5-phenyl-2,3,4,5-tetrahydro-1,4-benzothiazepin-8-yl  $\square$ -D-glucopyranosiduronic acid (EP 864 582).

30 A further suitable compound possessing IBAT inhibitory activity is S-8921 (EP 597 107).

A further suitable IBAT inhibitor is the compound:

- 6 -

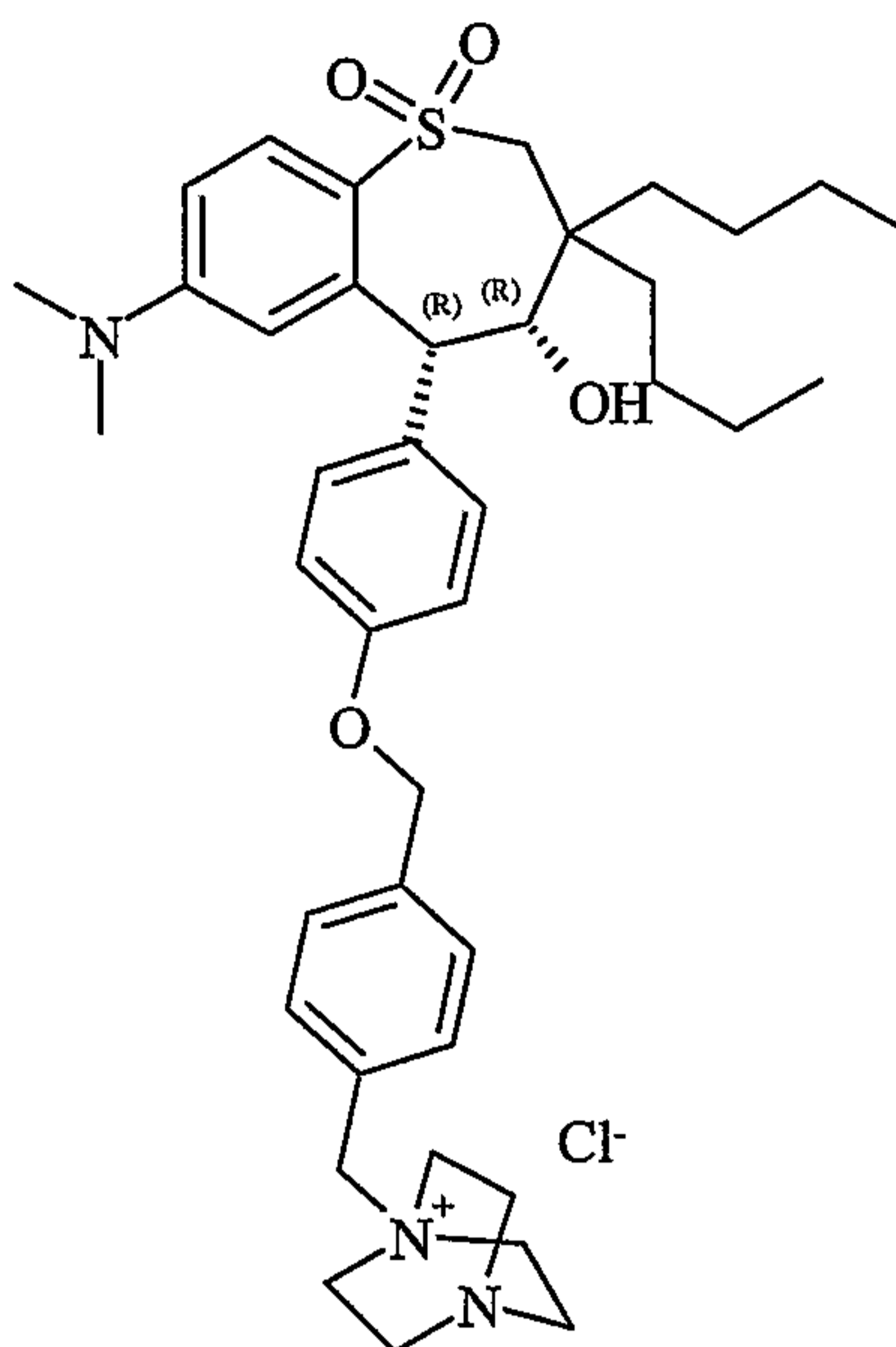

WO 99/32478

Other suitable compounds of the invention are the IBAT inhibitors described in WO 01/66533. A particular compound of the invention is selected from any one of Example 1-39  
 5 of WO 01/66533, or a pharmaceutically acceptable salt, solvate, solvate of such a salt or a prodrug thereof, and the compounds of Examples 1-39 are incorporated herein by reference. Claims 1-6 of WO 01/66533 are also incorporated herein by reference.

Additional suitable compounds of the invention are the IBAT inhibitors described in  
 10 WO 02/50051. A particular compound of the invention is selected from any one of Example 1-120 of WO 02/50051, or a pharmaceutically acceptable salt, solvate, solvate of such a salt or a prodrug thereof, and the compounds of Examples 1-120 are incorporated herein by reference. Claims 1-14 of WO 02/50051 are also incorporated herein by reference. A particular compound of the invention selected from WO 02/50051 is selected from any one of:

1,1-dioxo-3,3-dibutyl-5-phenyl-7-methylthio-8-(N-{(R)-1'-phenyl-1'-[N'-(carboxymethyl)  
 15 carbamoyl]methyl}carbamoylmethoxy)-2,3,4,5-tetrahydro-1,5-benzothiazepine;

1,1-dioxo-3,3-dibutyl-5-phenyl-7-methylthio-8-(N-{(R)- $\alpha$ -[N'-(carboxymethyl)carbamoyl]-4-hydroxybenzyl}  
 carbamoylmethoxy)-2,3,4,5-tetrahydro-1,5-benzothiazepine;

1,1-dioxo-3,3-dibutyl-5-phenyl-7-methylthio-8-(N-{(R)-1'-phenyl-1'-[N'-(2-sulphoethyl)  
 carbamoyl]methyl}carbamoylmethoxy)-2,3,4,5-tetrahydro-1,5-benzothiazepine;

20 1,1-dioxo-3-butyl-3-ethyl-5-phenyl-7-methylthio-8-(N-{(R)-1'-phenyl-1'-[N'-(2-sulphoethyl)  
 carbamoyl]methyl}carbamoylmethoxy)-2,3,4,5-tetrahydro-1,5-benzothiazepine;

1,1-dioxo-3,3-dibutyl-5-phenyl-7-methylthio-8-(N-{(R)- $\alpha$ -[N'-(2-sulphoethyl)carbamoyl]-4-hydroxybenzyl}  
 carbamoylmethoxy)-2,3,4,5-tetrahydro-1,5-benzothiazepine;

- 7 -

- 1,1-dioxo-3-butyl-3-ethyl-5-phenyl-7-methylthio-8-(*N*-{(R)- $\alpha$ -[*N'*-(2-sulphoethyl) carbamoyl]-4-hydroxybenzyl} carbamoylmethoxy)-2,3,4,5-tetrahydro-1,5-benzothiazepine;
- 1,1-dioxo-3-butyl-3-ethyl-5-phenyl-7-methylthio-8-(*N*-{(R)- $\alpha$ -[*N'*-(2-carboxyethyl) carbamoyl]benzyl} carbamoylmethoxy)-2,3,4,5-tetrahydro-1,5-benzothiazepine;
- 5 1,1-dioxo-3,3-dibutyl-5-phenyl-7-methylthio-8-(*N*-{(R)- $\alpha$ -[*N'*-(2-carboxyethyl) carbamoyl]-4-hydroxybenzyl} carbamoylmethoxy)-2,3,4,5-tetrahydro-1,5-benzothiazepine;
- 1,1-dioxo-3-butyl-3-ethyl-5-phenyl-7-methylthio-8-(*N*-{(R)- $\alpha$ -[*N'*-(5-carboxypentyl) carbamoyl]benzyl} carbamoylmethoxy)-2,3,4,5-tetrahydro-1,5-benzothiazepine;
- 1,1-dioxo-3,3-dibutyl-5-phenyl-7-methylthio-8-(*N*-{(R)- $\alpha$ -[*N'*-(2-carboxyethyl) carbamoyl]benzyl} carbamoylmethoxy)-2,3,4,5-tetrahydro-1,5-benzothiazepine;
- 10 1,1-dioxo-3,3-dibutyl-5-phenyl-7-methylthio-8-(*N*-{ $\alpha$ -[*N'*-(2-sulphoethyl) carbamoyl]-2-fluorobenzyl} carbamoylmethoxy)-2,3,4,5-tetrahydro-1,5-benzothiazepine;
- 1,1-dioxo-3-butyl-3-ethyl-5-phenyl-7-methylthio-8-(*N*-{(R)- $\alpha$ -[*N'*-(R)-(2-hydroxy-1-carboxyethyl) carbamoyl]benzyl} carbamoylmethoxy)-2,3,4,5-tetrahydro-1,5-benzothiazepine;
- 15 1,1-dioxo-3,3-dibutyl-5-phenyl-7-methylthio-8-(*N*-{(R)- $\alpha$ -[*N'*-(R)-(2-hydroxy-1-carboxyethyl) carbamoyl]benzyl} carbamoylmethoxy)-2,3,4,5-tetrahydro-1,5-benzothiazepine;
- 1,1-dioxo-3,3-dibutyl-5-phenyl-7-methylthio-8-{*N*-[(R)- $\alpha$ -(*N'*-{(R)-1-[*N''*-(R)-(2-hydroxy-1-carboxyethyl) carbamoyl]-2-hydroxyethyl} carbamoyl)benzyl] carbamoylmethoxy}-2,3,4,5-tetrahydro-1,5-benzothiazepine;
- 20 1,1-dioxo-3-butyl-3-ethyl-5-phenyl-7-methylthio-8-(*N*-{ $\alpha$ -[*N'*-(carboxymethyl) carbamoyl]benzyl} carbamoylmethoxy)-2,3,4,5-tetrahydro-1,5-benzothiazepine;
- 1,1-dioxo-3-butyl-3-ethyl-5-phenyl-7-methylthio-8-(*N*-{ $\alpha$ -[*N'*-((ethoxy)(methyl)phosphoryl-methyl) carbamoyl]benzyl} carbamoylmethoxy)-2,3,4,5-tetrahydro-1,5-benzothiazepine;
- 1,1-dioxo-3-butyl-3-ethyl-5-phenyl-7-methylthio-8-{*N*-[(R)- $\alpha$ -(*N'*-{2-[(hydroxy)(methyl)phosphoryl]ethyl} carbamoyl)benzyl] carbamoylmethoxy}-2,3,4,5-tetrahydro-1,5-benzothiazepine;
- 25 1,1-dioxo-3,3-dibutyl-5-phenyl-7-methylthio-8-(*N*-{(R)- $\alpha$ -[*N'*-(2-methylthio-1-carboxyethyl) carbamoyl]benzyl} carbamoylmethoxy)-2,3,4,5-tetrahydro-1,5-benzothiazepine;
- 1,1-dioxo-3,3-dibutyl-5-phenyl-7-methylthio-8-{*N*-[(R)- $\alpha$ -(*N'*-{2-[(methyl)(ethyl) phosphoryl]ethyl} carbamoyl)-4-hydroxybenzyl] carbamoylmethoxy}-2,3,4,5-tetrahydro-1,5-benzothiazepine;
- 30

- 8 -

1,1-dioxo-3,3-dibutyl-5-phenyl-7-methylthio-8- $\{N-[(R)-\alpha-(N'-\{2-[(methyl)(hydroxy)phosphoryl]ethyl\}carbamoyl)-4-hydroxybenzyl]carbamoylmethoxy\}$ -2,3,4,5-tetrahydro-1,5-benzothiazepine;

1,1-dioxo-3,3-dibutyl-5-phenyl-7-methylthio-8- $(N-\{(R)-\alpha-[(R)-N'-(2-methylsulphinyl-1-carboxyethyl)carbamoyl]benzyl\}carbamoylmethoxy)$ -2,3,4,5-tetrahydro-1,5-benzothiazepine;  
5 and

1,1-dioxo-3,3-dibutyl-5-phenyl-7-methoxy-8- $[N-\{(R)-\alpha-[N'-(2-sulphoethyl)carbamoyl]-4-hydroxybenzyl\}carbamoylmethoxy]$ -2,3,4,5-tetrahydro-1,5-benzothiazepine;

or a pharmaceutically acceptable salt, solvate, solvate of such a salt or a prodrug thereof.

10 Additional suitable compounds of the invention are the IBAT inhibitors described in WO 03/020710. A particular compound of the invention is selected from any one of Example 1-44 of WO 03/020710, or a pharmaceutically acceptable salt, solvate, solvate of such a salt or a prodrug thereof, and the compounds of Examples 1-44 are incorporated herein by reference.

Claims 1-10 of WO 03/020710 are also incorporated herein by reference. A particular  
15 compound of the invention selected from WO 03/020710 is selected from any one of:

1,1-dioxo-3,3-dibutyl-5-phenyl-7-methylthio-8- $(N-\{(R)-\alpha-[N'-(2-(S)-3-(R)-4-(R)-5-(R)-2,3,4,5,6-pentahydroxyhexyl)carbamoyl]benzyl\}carbamoylmethoxy)$ -2,3,4,5-tetrahydro-1,5-benzothiazepine;

1,1-dioxo-3-butyl-3-ethyl-5-phenyl-7-methylthio-8- $(N-\{(R)-\alpha-[N'-(2-(S)-3-(R)-4-(R)-5-(R)-2,3,4,5,6-pentahydroxyhexyl)carbamoyl]benzyl\}carbamoylmethoxy)$ -2,3,4,5-tetrahydro-1,5-benzothiazepine;  
20

1,1-dioxo-3-butyl-3-ethyl-5-phenyl-7-methylthio-8- $(N-\{(R)-\alpha-[N'-(S)-1-carbamoyl-2-hydroxyethyl]carbamoyl]benzyl\}carbamoylmethoxy)$ -2,3,4,5-tetrahydro-1,5-benzothiazepine;

1,1-dioxo-3-butyl-3-ethyl-5-phenyl-7-methylthio-8- $(N-\{(R)-\alpha-[N'-(hydroxycarbamoyl-methyl)carbamoyl]benzyl\}carbamoylmethoxy)$ -2,3,4,5-tetrahydro-1,5-benzothiazepine;  
25

1,1-dioxo-3-butyl-3-ethyl-5-phenyl-7-methylthio-8- $[N-((R)-\alpha-\{N'-[2-(N'-pyrimidin-2-ylureido)ethyl]carbamoyl\}benzyl)carbamoylmethoxy]$ -2,3,4,5-tetrahydro-1,5-benzothiazepine;

1,1-dioxo-3-butyl-3-ethyl-5-phenyl-7-methylthio-8- $[N-((R)-\alpha-\{N'-[2-(N'-pyridin-2-ylureido)ethyl]carbamoyl\}benzyl)carbamoylmethoxy]$ -2,3,4,5-tetrahydro-1,5-benzothiazepine;

30 1,1-dioxo-3-butyl-3-ethyl-5-phenyl-7-methylthio-8- $(N-\{(R)-\alpha-[N'-(1-t-butoxycarbonylpiperidin-4-ylmethyl)carbamoyl]benzyl\}carbamoylmethoxy)$ -2,3,4,5-tetrahydro-1,5-benzothiazepine;

- 9 -

1,1-dioxo-3-butyl-3-ethyl-5-phenyl-7-methylthio-8-(*N*-{(R)- $\alpha$ -[*N'*-(2,3-dihydroxypropyl)carbamoyl]benzyl}carbamoylmethoxy)-2,3,4,5-tetrahydro-1,5-benzothiazepine;

5 1,1-dioxo-3-butyl-3-ethyl-5-phenyl-7-methylthio-8-[*N*-{(R)- $\alpha$ -{*N'*-[2-(3,4-dihydroxyphenyl)-2-methoxyethyl]carbamoyl}benzyl}carbamoylmethoxy]-2,3,4,5-tetrahydro-1,5-benzothiazepine

1,1-dioxo-3-butyl-3-ethyl-5-phenyl-7-methylthio-8-(*N*-{(R)- $\alpha$ -[*N'*-(2-aminoethyl)carbamoyl]benzyl}carbamoylmethoxy)-2,3,4,5-tetrahydro-1,5-benzothiazepine;

10 1,1-dioxo-3-butyl-3-ethyl-5-phenyl-7-methylthio-8-(*N*-{(R)- $\alpha$ -[*N'*-(piperidin-4-ylmethyl)carbamoyl]benzyl}carbamoylmethoxy)-2,3,4,5-tetrahydro-1,5-benzothiazepine; or

1,1-dioxo-3-butyl-3-ethyl-5-phenyl-7-methylthio-8-(*N*-{(R)- $\alpha$ -[*N'*-(2-*N,N*-dimethylaminosulphamoyl)ethyl]carbamoyl]benzyl}carbamoylmethoxy)-2,3,4,5-tetrahydro-1,5-benzothiazepine;

or a pharmaceutically acceptable salt, solvate, solvate of such a salt or a prodrug thereof.

15 Additional suitable compounds of the invention are the IBAT inhibitors described in WO 03/022825. A particular compound of the invention is selected from any one of Example 1-7 of WO 03/022825, or a pharmaceutically acceptable salt, solvate, solvate of such a salt or a prodrug thereof, and the compounds of Examples 1-7 are incorporated herein by reference.

20 Claims 1-8 of WO 03/022825 are also incorporated herein by reference. A particular compound of the invention selected from WO 03/022825 is selected from any one of:

1,1-dioxo-3(R)-3-butyl-3-ethyl-5-(R)-5-phenyl-8-[*N*-{(R)- $\alpha$ -carboxybenzyl}carbamoylmethoxy]-2,3,4,5-tetrahydro-1,4-benzothiazepine;

1,1-dioxo-3(S)-3-butyl-3-ethyl-5-(S)-5-phenyl-8-[*N*-{(R)- $\alpha$ -carboxybenzyl}carbamoylmethoxy]-2,3,4,5-tetrahydro-1,4-benzothiazepine;

25 1,1-dioxo-3(R)-3-butyl-3-ethyl-5-(R)-5-phenyl-8-(*N*-{(R)- $\alpha$ -[*N*-(carboxymethyl)carbamoyl]benzyl}carbamoylmethoxy)-2,3,4,5-tetrahydro-1,4-benzothiazepine;

1,1-dioxo-3(S)-3-butyl-3-ethyl-5-(S)-5-phenyl-8-(*N*-{(R)- $\alpha$ -[*N*-(carboxymethyl)carbamoyl]benzyl}carbamoylmethoxy)-2,3,4,5-tetrahydro-1,4-benzothiazepine;

30 3,5-*trans*-1,1-dioxo-3-ethyl-3-butyl-5-phenyl-7-bromo-8-(*N*-{(R)- $\alpha$ -[*N*-(carboxymethyl)carbamoyl]benzyl}carbamoylmethoxy)-2,3,4,5-tetrahydro-1,4-benzothiazepine;

3,5-*trans*-1,1-dioxo-3-(S)-3-ethyl-3-butyl-4-hydroxy-5-(S)-5-phenyl-7-bromo-8-(*N*-{(R)- $\alpha$ -[*N*-(carboxymethyl)carbamoyl]benzyl}carbamoylmethoxy)-2,3,4,5-tetrahydro-1,4-benzothiazepine

3,5-*trans*-1,1-dioxo-3-(R)-3-ethyl-3-butyl-4-hydroxy-5-(R)-5-phenyl-7-bromo-8-(*N*-{(R)- $\alpha$ -[*N*-(carboxymethyl)carbamoyl]benzyl}carbamoylmethoxy)-2,3,4,5-tetrahydro-1,4-benzothiazepine;

3,5-*trans*-1,1-dioxo-3-ethyl-3-butyl-5-phenyl-7-methylthio-8-(*N*-{(R)- $\alpha$ -[*N*-(carboxymethyl)carbamoyl]benzyl}carbamoylmethoxy)-2,3,4,5-tetrahydro-1,4-benzothiazepine;

10 3,5-*trans*-1,1-dioxo-3-ethyl-3-butyl-5-phenyl-7-methylthio-8-(*N*-{(R)- $\alpha$ -[*N*-(2-sulphoethyl)carbamoyl]-4-hydroxybenzyl}carbamoylmethoxy)-2,3,4,5-tetrahydro-1,4-benzothiazepine ammonia salt;

1,1-dioxo-3-(S)-3-ethyl-3-butyl-5-(S)-5-phenyl-7-methylthio-8-(*N*-{(R)- $\alpha$ -[*N*-(carboxymethyl)carbamoyl]benzyl}carbamoylmethoxy)-2,3,4,5-tetrahydro-1,4-benzothiazepine diethylamine salt; and

1,1-dioxo-3-(R)-3-ethyl-3-butyl-5-(R)-5-phenyl-7-methylthio-8-(*N*-{(R)- $\alpha$ -[*N*-(carboxymethyl)carbamoyl]benzyl}carbamoylmethoxy)-2,3,4,5-tetrahydro-1,4-benzothiazepine diethylamine salt;

or a pharmaceutically acceptable salt, solvate, solvate of such a salt or a prodrug thereof.

20 Additional suitable compounds of the invention are the IBAT inhibitors described in WO 03/022830. A particular compound of the invention is selected from any one of Example 1-4 of WO 03/022830, or a pharmaceutically acceptable salt, solvate, solvate of such a salt or a prodrug thereof, and the compounds of Examples 1-4 are incorporated herein by reference. Claims 1-8 of WO 03/022830 are also incorporated herein by reference. A particular

25 compound of the invention selected from WO 03/022830 is selected from any one of:  
1,1-dioxo-3-butyl-3-ethyl-4-hydroxy-5-phenyl-7-(*N*-{(R)- $\alpha$ -[*N*-(carboxymethyl)carbamoyl]benzyl}carbamoylmethylthio)-2,3,4,5-tetrahydrobenzothiepine

1,1-dioxo-3-butyl-3-ethyl-4-hydroxy-5-phenyl-7-(*N*-{(R)- $\alpha$ -[*N*-(2-sulphoethyl)carbamoyl]-4-hydroxybenzyl}carbamoylmethylthio)-2,3,4,5-tetrahydrobenzothiepine ammonia salt

30 1,1-dioxo-3-butyl-3-ethyl-4-hydroxy-5-phenyl-7-{*N*-[ $\alpha$ -(carboxy)-2-fluorobenzyl]carbamoylmethylthio}-2,3,4,5-tetrahydrobenzothiepine; and

- 11 -

1,1-dioxo-3-butyl-3-ethyl-4-hydroxy-5-phenyl-7- $\{N$ -[1-(carboxy)-1-(thien-2-yl)methyl] carbamoylmethylthio}-2,3,4,5-tetrahydrobenzothiepine

or a pharmaceutically acceptable salt, solvate, solvate of such a salt or a prodrug thereof.

Additional suitable compounds of the invention are the IBAT inhibitors described in  
 5 WO 03/022286. A particular compound of the invention is selected from any one of Example 1-39 of WO 03/022286, or a pharmaceutically acceptable salt, solvate, solvate of such a salt or a prodrug thereof, and the compounds of Examples 1-39 are incorporated herein by reference.

Claims 1-10 of WO 03/022286 are also incorporated herein by reference. A particular compound of the invention selected from WO 03/022286 is selected from any one of:

10 1,1-dioxo-3,3-dibutyl-5-phenyl-7-methylthio-8- $(N$ -{(R)- $\alpha$ -[ $N$ -((R)-1-carboxy-2-methylthio-ethyl)carbamoyl]-4-hydroxybenzyl} carbamoylmethoxy)-2,3,4,5-tetrahydro-1,2,5-benzothiadiazepine;

1,1-dioxo-3,3-dibutyl-5-phenyl-7-methylthio-8- $(N$ -{(R)- $\alpha$ -[ $N$ -((S)-1-carboxy-2-(R)-hydroxypropyl)carbamoyl]-4-hydroxybenzyl} carbamoylmethoxy)-2,3,4,5-tetrahydro-1,2,5-  
 15 benzothiadiazepine;

1,1-dioxo-3,3-dibutyl-5-phenyl-7-methylthio-8- $(N$ -{(R)- $\alpha$ -[ $N$ -((S)-1-carboxy-2-methylpropyl)carbamoyl]-4-hydroxybenzyl} carbamoylmethoxy)-2,3,4,5-tetrahydro-1,2,5-benzothiadiazepine;

1,1-dioxo-3,3-dibutyl-5-phenyl-7-methylthio-8- $(N$ -{(R)- $\alpha$ -[ $N$ -((S)-1-carboxybutyl) carbamoyl]-4-hydroxybenzyl} carbamoylmethoxy)-2,3,4,5-tetrahydro-1,2,5-  
 20 benzothiadiazepine;

1,1-dioxo-3,3-dibutyl-5-phenyl-7-methylthio-8- $(N$ -{(R)- $\alpha$ -[ $N$ -((S)-1-carboxypropyl) carbamoyl]benzyl} carbamoylmethoxy)-2,3,4,5-tetrahydro-1,2,5-benzothiadiazepine;

1,1-dioxo-3,3-dibutyl-5-phenyl-7-methylthio-8- $(N$ -{(R)- $\alpha$ -[ $N$ -((S)-1-carboxyethyl) carbamoyl]benzyl} carbamoylmethoxy)-2,3,4,5-tetrahydro-1,2,5-benzothiadiazepine;  
 25

1,1-dioxo-3,3-dibutyl-5-phenyl-7-methylthio-8- $(N$ -{(R)- $\alpha$ -[ $N$ -((S)-1-carboxy-2-(R)-hydroxypropyl)carbamoyl]benzyl} carbamoylmethoxy)-2,3,4,5-tetrahydro-1,2,5-benzothiadiazepine;

1,1-dioxo-3,3-dibutyl-5-phenyl-7-methylthio-8- $(N$ -{(R)- $\alpha$ -[ $N$ -(2-sulphoethyl)carbamoyl]-4-  
 30 hydroxybenzyl} carbamoylmethoxy)-2,3,4,5-tetrahydro-1,2,5-benzothiadiazepine;

- 12 -

1,1-dioxo-3,3-dibutyl-5-phenyl-7-methylthio-8-(*N*-{(R)- $\alpha$ -[*N*-((S)-1-carboxyethyl)carbamoyl]-4-hydroxybenzyl}carbamoylmethoxy)-2,3,4,5-tetrahydro-1,2,5-benzothiadiazepine;

1,1-dioxo-3,3-dibutyl-5-phenyl-7-methylthio-8-(*N*-{(R)- $\alpha$ -[*N*-((R)-1-carboxy-2-methylthioethyl)carbamoyl]benzyl}carbamoylmethoxy)-2,3,4,5-tetrahydro-1,2,5-benzothiadiazepine;

1,1-dioxo-3,3-dibutyl-5-phenyl-7-methylthio-8-(*N*-{(R)- $\alpha$ -[*N*-{(S)-1-[*N*-((S)-2-hydroxy-1-carboxyethyl)carbamoyl]propyl}carbamoyl]benzyl}carbamoylmethoxy)-2,3,4,5-tetrahydro-1,2,5-benzothiadiazepine; and

1,1-dioxo-3,3-dibutyl-5-phenyl-7-methylthio-8-(*N*-{(R)- $\alpha$ -[*N*-((S)-1-carboxy-2-methylpropyl)carbamoyl]benzyl}carbamoylmethoxy)-2,3,4,5-tetrahydro-1,2,5-benzothiadiazepine;

or a pharmaceutically acceptable salt, solvate, solvate of such a salt or a prodrug thereof.

A further particular compound of the invention selected from WO 03/022286 is selected from any one of:

1,1-dioxo-3,3-dibutyl-5-phenyl-7-methylthio-8-(*N*-{(R)- $\alpha$ -[*N*-((S)-1-carboxypropyl)carbamoyl]-4-hydroxybenzyl}carbamoylmethoxy)-2,3,4,5-tetrahydro-1,2,5-benzothiadiazepine; and

1,1-dioxo-3,3-dibutyl-5-phenyl-7-methylthio-8-[*N*-((R)- $\alpha$ -carboxy-4-hydroxybenzyl)carbamoylmethoxy]-2,3,4,5-tetrahydro-1,2,5-benzothiadiazepine;

or a pharmaceutically acceptable salt, solvate, solvate of such a salt or a prodrug thereof.

Further suitable IBAT inhibitors are those having the structure:

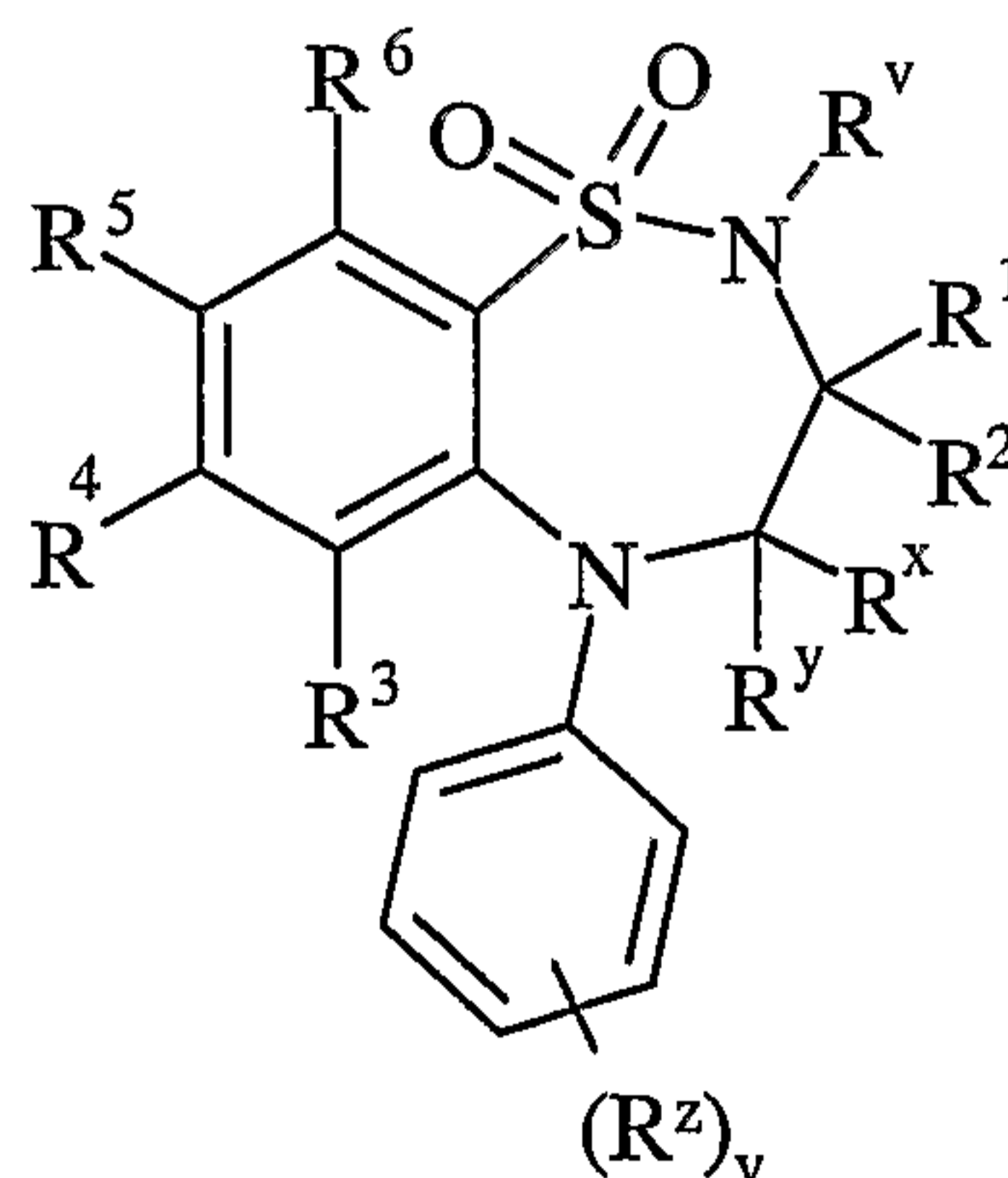

(I)

25 wherein:

$R^v$  is selected from hydrogen or  $C_{1-6}$ alkyl;

- 13 -

One of  $R^1$  and  $R^2$  are selected from hydrogen or  $C_{1-6}$ alkyl and the other is selected from  $C_{1-6}$ alkyl;

$R^x$  and  $R^y$  are independently selected from hydrogen, hydroxy, amino, mercapto,  $C_{1-6}$ alkyl,  $C_{1-6}$ alkoxy,  $N-(C_{1-6}alkyl)amino$ ,  $N,N-(C_{1-6}alkyl)_2amino$ ,  $C_{1-6}alkylS(O)_a$  wherein a is 0 to 2;

$R^z$  is selected from halo, nitro, cyano, hydroxy, amino, carboxy, carbamoyl, mercapto, sulphamoyl,  $C_{1-6}alkyl$ ,  $C_{2-6}alkenyl$ ,  $C_{2-6}alkynyl$ ,  $C_{1-6}alkoxy$ ,  $C_{1-6}alkanoyl$ ,  $C_{1-6}alkanoyloxy$ ,  $N-(C_{1-6}alkyl)amino$ ,  $N,N-(C_{1-6}alkyl)_2amino$ ,  $C_{1-6}alkanoylamino$ ,  $N-(C_{1-6}alkyl)carbamoyl$ ,  $N,N-(C_{1-6}alkyl)_2carbamoyl$ ,  $C_{1-6}alkylS(O)_a$  wherein a is 0 to 2,  $C_{1-6}alkoxycarbonyl$ ,  $N-(C_{1-6}alkyl)sulphamoyl$  and  $N,N-(C_{1-6}alkyl)_2sulphamoyl$ ;

v is 0-5;

one of  $R^4$  and  $R^5$  is a group of formula (IA):

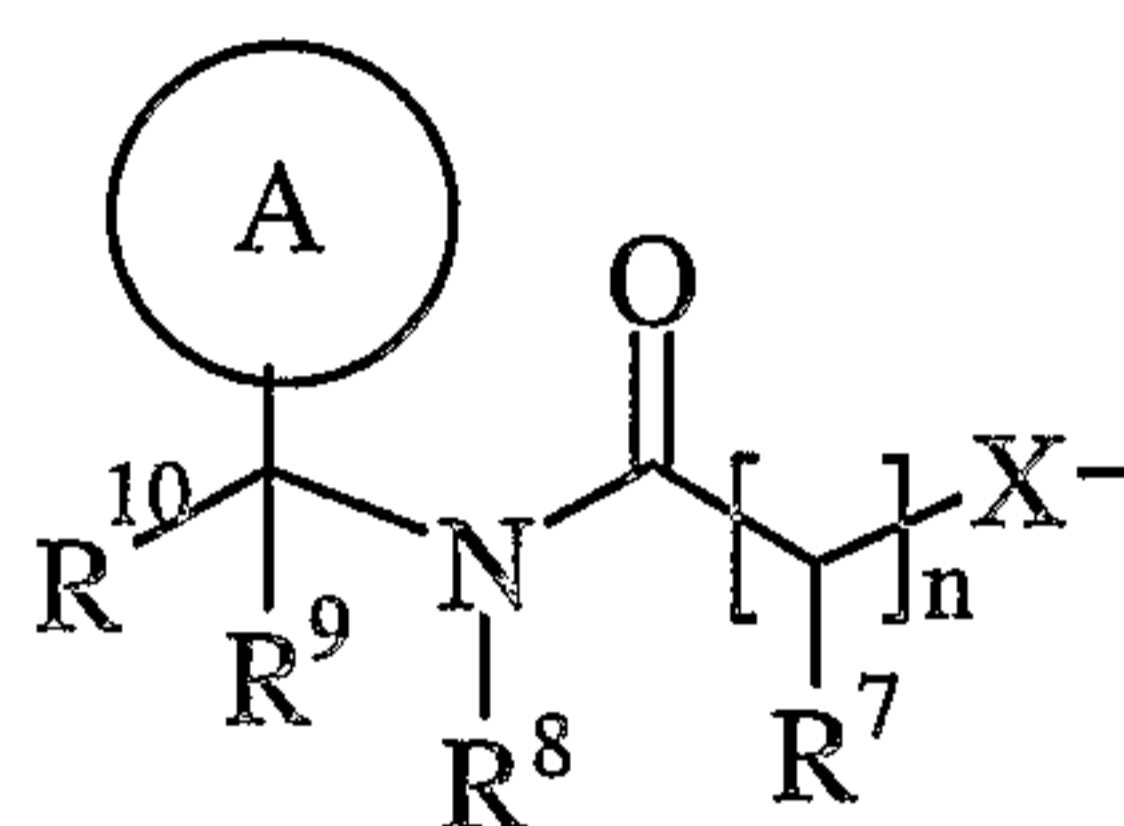

(IA)

$R^3$  and  $R^6$  and the other of  $R^4$  and  $R^5$  are independently selected from hydrogen, halo, nitro, cyano, hydroxy, amino, carboxy, carbamoyl, mercapto, sulphamoyl,  $C_{1-6}alkyl$ ,  $C_{2-6}alkenyl$ ,  $C_{2-6}alkynyl$ ,  $C_{1-6}alkoxy$ ,  $C_{1-6}alkanoyl$ ,  $C_{1-6}alkanoyloxy$ ,  $N-(C_{1-6}alkyl)amino$ ,  $N,N-(C_{1-6}alkyl)_2amino$ ,  $C_{1-6}alkanoylamino$ ,  $N-(C_{1-6}alkyl)carbamoyl$ ,  $N,N-(C_{1-6}alkyl)_2carbamoyl$ ,  $C_{1-6}alkylS(O)_a$  wherein a is 0 to 2,  $C_{1-6}alkoxycarbonyl$ ,  $N-(C_{1-6}alkyl)sulphamoyl$  and  $N,N-(C_{1-6}alkyl)_2sulphamoyl$ ; wherein  $R^3$  and  $R^6$  and the other of  $R^4$  and  $R^5$  may be optionally substituted on carbon by one or more  $R^{17}$ ;

X is  $-O-$ ,  $-N(R^a)-$ ,  $-S(O)_b-$  or  $-CH(R^a)-$ ; wherein  $R^a$  is hydrogen or  $C_{1-6}alkyl$  and b is 0-2;

Ring A is aryl or heteroaryl; wherein Ring A is optionally substituted on carbon by one or more substituents selected from  $R^{18}$ ;

$R^7$  is hydrogen,  $C_{1-6}alkyl$ , carbocyclyl or heterocyclyl; wherein  $R^7$  is optionally substituted on carbon by one or more substituents selected from  $R^{19}$ ; and wherein if said heterocyclyl contains an  $-NH-$  group, that nitrogen may be optionally substituted by a group selected from  $R^{20}$ ;

- 14 -

$R^8$  is hydrogen or  $C_{1-6}$ alkyl;

$R^9$  is hydrogen or  $C_{1-6}$ alkyl;

$R^{10}$  is hydrogen, halo, nitro, cyano, hydroxy, amino, carbamoyl, mercapto, sulphamoyl, hydroxyaminocarbonyl,  $C_{1-10}$ alkyl,  $C_{2-10}$ alkenyl,  $C_{2-10}$ alkynyl,  $C_{1-10}$ alkoxy,  $C_{1-10}$ alkanoyl,  $C_{1-10}$ alkanoyloxy,  $N$ -( $C_{1-10}$ alkyl)amino,  $N,N$ -( $C_{1-10}$ alkyl)<sub>2</sub>amino,  $N,N,N$ -( $C_{1-10}$ alkyl)<sub>3</sub>ammonio,  $C_{1-10}$ alkanoylamino,  $N$ -( $C_{1-10}$ alkyl)carbamoyl,  $N,N$ -( $C_{1-10}$ alkyl)<sub>2</sub>carbamoyl,  $C_{1-10}$ alkylS(O)<sub>a</sub> wherein a is 0 to 2,  $N$ -( $C_{1-10}$ alkyl)sulphamoyl,  $N,N$ -( $C_{1-10}$ alkyl)<sub>2</sub>sulphamoyl,  $N$ -( $C_{1-10}$ alkyl)sulphamoylamino,  $N,N$ -( $C_{1-10}$ alkyl)<sub>2</sub>sulphamoylamino,  $C_{1-10}$ alkoxycarbonylamino, carbocyclyl, carbocyclyl $C_{1-10}$ alkyl, heterocyclyl, heterocyclyl $C_{1-10}$ alkyl, carbocyclyl-( $C_{1-10}$ alkylene)<sub>p</sub>- $R^{21}$ -( $C_{1-10}$ alkylene)<sub>q</sub>- or heterocyclyl-( $C_{1-10}$ alkylene)<sub>r</sub>- $R^{22}$ -( $C_{1-10}$ alkylene)<sub>s</sub>-; wherein  $R^{10}$  is optionally substituted on carbon by one or more substituents selected from  $R^{23}$ ; and wherein if said heterocyclyl contains an -NH- group, that nitrogen may be optionally substituted by a group selected from  $R^{24}$ ; or  $R^{10}$  is a group of formula (IB):

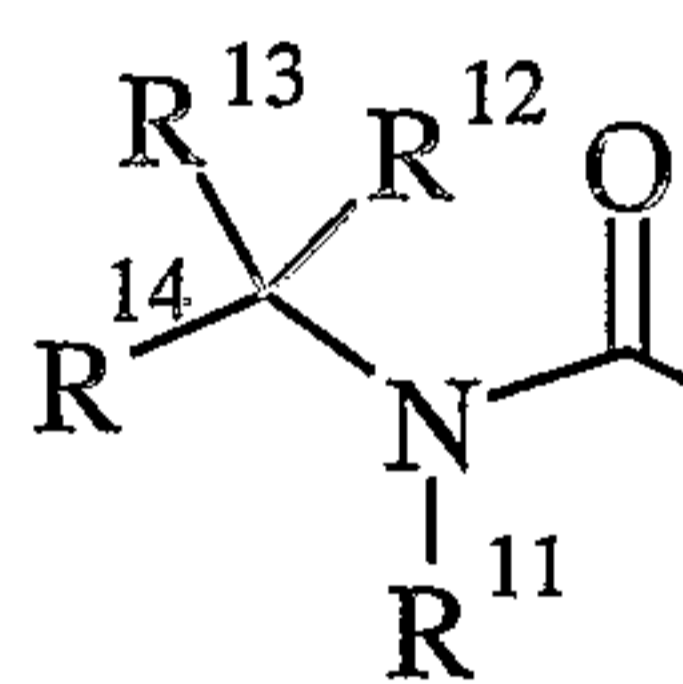

(IB)

wherein:

$R^{11}$  is hydrogen or  $C_{1-6}$ alkyl;

$R^{12}$  and  $R^{13}$  are independently selected from hydrogen, halo, carbamoyl, sulphamoyl,  $C_{1-10}$ alkyl,  $C_{2-10}$ alkenyl,  $C_{2-10}$ alkynyl,  $C_{1-10}$ alkanoyl,  $N$ -( $C_{1-10}$ alkyl)carbamoyl,  $N,N$ -( $C_{1-10}$ alkyl)<sub>2</sub>carbamoyl,  $C_{1-10}$ alkylS(O)<sub>a</sub> wherein a is 0 to 2,  $N$ -( $C_{1-10}$ alkyl)sulphamoyl,  $N,N$ -( $C_{1-10}$ alkyl)<sub>2</sub>sulphamoyl,  $N$ -( $C_{1-10}$ alkyl)sulphamoylamino,  $N,N$ -( $C_{1-10}$ alkyl)<sub>2</sub>sulphamoylamino, carbocyclyl or heterocyclyl; wherein  $R^{12}$  and  $R^{13}$  may be independently optionally substituted on carbon by one or more substituents selected from  $R^{25}$ ; and wherein if said heterocyclyl contains an -NH- group, that nitrogen may be optionally substituted by a group selected from  $R^{26}$ ;

$R^{14}$  is selected from hydrogen, halo, carbamoyl, sulphamoyl, hydroxyaminocarbonyl,  $C_{1-10}$ alkyl,  $C_{2-10}$ alkenyl,  $C_{2-10}$ alkynyl,  $C_{1-10}$ alkanoyl,  $N$ -( $C_{1-10}$ alkyl)carbamoyl,  $N,N$ -( $C_{1-10}$ alkyl)<sub>2</sub>carbamoyl,  $C_{1-10}$ alkylS(O)<sub>a</sub> wherein a is 0 to 2,  $N$ -( $C_{1-10}$ alkyl)sulphamoyl,

- 15 -

*N,N*-(C<sub>1-10</sub>alkyl)<sub>2</sub>sulphamoyl, *N*-(C<sub>1-10</sub>alkyl)sulphamoylamino,  
*N,N*-(C<sub>1-10</sub>alkyl)<sub>2</sub>sulphamoylamino, carbocyclyl, carbocyclylC<sub>1-10</sub>alkyl, heterocyclyl,  
heterocyclylC<sub>1-10</sub>alkyl, carbocyclyl-(C<sub>1-10</sub>alkylene)<sub>p</sub>-R<sup>27</sup>-(C<sub>1-10</sub>alkylene)<sub>q</sub>- or  
heterocyclyl-(C<sub>1-10</sub>alkylene)<sub>r</sub>-R<sup>28</sup>-(C<sub>1-10</sub>alkylene)<sub>s</sub>-; wherein R<sup>14</sup> may be optionally substituted  
5 on carbon by one or more substituents selected from R<sup>29</sup>; and wherein if said heterocyclyl  
contains an -NH- group, that nitrogen may be optionally substituted by a group selected from  
R<sup>30</sup>; or R<sup>14</sup> is a group of formula (IC):

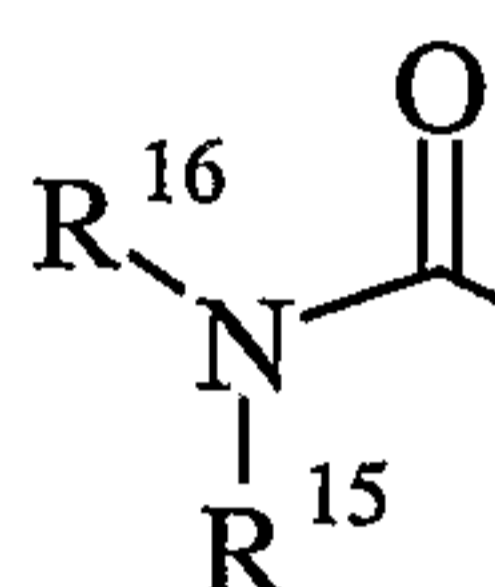

(IC)

10 R<sup>15</sup> is hydrogen or C<sub>1-6</sub>alkyl; and R<sup>16</sup> is hydrogen or C<sub>1-6</sub>alkyl; wherein R<sup>16</sup> may be  
optionally substituted on carbon by one or more groups selected from R<sup>31</sup>; or R<sup>15</sup> and R<sup>16</sup>  
together with the nitrogen to which they are attached form a heterocyclyl; wherein said  
heterocyclyl may be optionally substituted on carbon by one or more R<sup>37</sup>; and wherein if said  
heterocyclyl contains an -NH- group, that nitrogen may be optionally substituted by a group  
15 selected from R<sup>38</sup>;

n is 1-3; wherein the values of R<sup>7</sup> may be the same or different;

R<sup>17</sup>, R<sup>18</sup>, R<sup>19</sup>, R<sup>23</sup>, R<sup>25</sup>, R<sup>29</sup>, R<sup>31</sup> and R<sup>37</sup> are independently selected from halo, nitro,  
cyano, hydroxy, amino, carbamoyl, mercapto, sulphamoyl, hydroxyaminocarbonyl, C<sub>1-10</sub>alkyl,  
C<sub>2-10</sub>alkenyl, C<sub>2-10</sub>alkynyl, C<sub>1-10</sub>alkoxy, C<sub>1-10</sub>alkanoyl, C<sub>1-10</sub>alkanoyloxy, *N*-(C<sub>1-10</sub>alkyl)amino,  
20 *N,N*-(C<sub>1-10</sub>alkyl)<sub>2</sub>amino, *N,N,N*-(C<sub>1-10</sub>alkyl)<sub>3</sub>ammonio, C<sub>1-10</sub>alkanoylamino,  
*N*-(C<sub>1-10</sub>alkyl)carbamoyl, *N,N*-(C<sub>1-10</sub>alkyl)<sub>2</sub>carbamoyl, C<sub>1-10</sub>alkylS(O)<sub>a</sub> wherein a is 0 to 2,  
*N*-(C<sub>1-10</sub>alkyl)sulphamoyl, *N,N*-(C<sub>1-10</sub>alkyl)<sub>2</sub>sulphamoyl, *N*-(C<sub>1-10</sub>alkyl)sulphamoylamino,  
*N,N*-(C<sub>1-10</sub>alkyl)<sub>2</sub>sulphamoylamino, C<sub>1-10</sub>alkoxycarbonylamino, carbocyclyl,  
carbocyclylC<sub>1-10</sub>alkyl, heterocyclyl, heterocyclylC<sub>1-10</sub>alkyl,  
25 carbocyclyl-(C<sub>1-10</sub>alkylene)<sub>p</sub>-R<sup>32</sup>-(C<sub>1-10</sub>alkylene)<sub>q</sub>- or  
heterocyclyl-(C<sub>1-10</sub>alkylene)<sub>r</sub>-R<sup>33</sup>-(C<sub>1-10</sub>alkylene)<sub>s</sub>-; wherein R<sup>17</sup>, R<sup>18</sup>, R<sup>19</sup>, R<sup>23</sup>, R<sup>25</sup>, R<sup>29</sup>, R<sup>31</sup>  
and R<sup>37</sup> may be independently optionally substituted on carbon by one or more R<sup>34</sup>; and  
wherein if said heterocyclyl contains an -NH- group, that nitrogen may be optionally  
substituted by a group selected from R<sup>35</sup>;

- 16 -

$R^{21}$ ,  $R^{22}$ ,  $R^{27}$ ,  $R^{28}$ ,  $R^{32}$  or  $R^{33}$  are independently selected from -O-,  $-NR^{36}$ -,  $-S(O)_x$ -,  $-NR^{36}C(O)NR^{36}$ -,  $-NR^{36}C(S)NR^{36}$ -,  $-OC(O)N=C$ -,  $-NR^{36}C(O)$ - or  $-C(O)NR^{36}$ -; wherein  $R^{36}$  is selected from hydrogen or  $C_{1-6}$ alkyl, and x is 0-2;

p, q, r and s are independently selected from 0-2;

5  $R^{34}$  is selected from halo, hydroxy, cyano, carbamoyl, ureido, amino, nitro, carbamoyl, mercapto, sulphamoyl, trifluoromethyl, trifluoromethoxy, methyl, ethyl, methoxy, ethoxy, vinyl, allyl, ethynyl, formyl, acetyl, formamido, acetylamino, acetoxymethyl, methylamino, dimethylamino, *N*-methylcarbamoyl, *N,N*-dimethylcarbamoyl, methylthio, methylsulphinyl, mesyl, *N*-methylsulphamoyl, *N,N*-dimethylsulphamoyl, *N*-methylsulphamoylamino and  
10 *N,N*-dimethylsulphamoylamino;

$R^{20}$ ,  $R^{24}$ ,  $R^{26}$ ,  $R^{30}$ ,  $R^{35}$  and  $R^{38}$  are independently selected from  $C_{1-6}$ alkyl,  $C_{1-6}$ alkanoyl,  $C_{1-6}$ alkylsulphonyl,  $C_{1-6}$ alkoxycarbonyl, carbamoyl, *N*-( $C_{1-6}$ alkyl)carbamoyl, *N,N*-( $C_{1-6}$ alkyl)carbamoyl, benzyl, benzyloxycarbonyl, benzoyl and phenylsulphonyl; or a pharmaceutically acceptable salt, solvate, solvate of such a salt or a prodrug thereof.

15 Suitable IBAT inhibitors having the above structure are selected from any one of:

1,1-Dioxo-3,3-dibutyl-5-phenyl-7-methylthio-8-(*N*-{(R)- $\alpha$ -[*N*-(2-(S)-3-(R)-4-(R)-5-(R)-2,3,4,5,6-pentahydroxyhexyl)carbamoyl]benzyl}carbamoylmethoxy)-2,3,4,5-tetrahydro-1,2,5-benzothiadiazepine;

1,1-Dioxo-3,3-dibutyl-5-phenyl-7-methylthio-8-(*N*-{(R)- $\alpha$ -[*N*-(2-(S)-3-(R)-4-(R)-5-(R)-2,3,4,5,6-pentahydroxyhexyl)carbamoyl]-4-hydroxybenzyl}carbamoylmethoxy)-2,3,4,5-tetrahydro-1,2,5-benzothiadiazepine;

1,1-Dioxo-3,3-dibutyl-5-phenyl-7-methylthio-8-[*N*-((R/S)- $\alpha$ -{*N*-[1-(R)-2-(S)-1-hydroxy-1-(3,4-dihydroxyphenyl)prop-2-yl]carbamoyl}benzyl)carbamoylmethoxy]-2,3,4,5-tetrahydro-1,2,5-benzothiadiazepine (both enantiomers);

25 1,1-Dioxo-3,3-dibutyl-5-phenyl-7-methylthio-8-{*N*-[(R)- $\alpha$ -(*N*-{2-(S)-[*N*-(carbamoylmethyl)carbamoyl]pyrrolidin-1-ylcarbonylmethyl}carbamoyl)benzyl]carbamoylmethoxy}-2,3,4,5-tetrahydro-1,2,5-benzothiadiazepine;

1,1-Dioxo-3,3-dibutyl-5-phenyl-7-methylthio-8-[*N*-((R)- $\alpha$ -{*N*-[2-(3,4,5-trihydroxyphenyl)ethyl]carbamoyl}benzyl)carbamoylmethoxy]-2,3,4,5-tetrahydro-1,2,5-benzothiadiazepine; or  
30

- 17 -

1,1-Dioxo-3,3-dibutyl-5-phenyl-7-methylthio-8-(*N*-{(R)- $\alpha$ -[*N*-(2-(R)-3-(S)-4-(S)-5-(R)-3,4,5,6-tetrahydroxytetrahydropyran-2-ylmethyl)carbamoyl]benzyl}carbamoylmethoxy)-2,3,4,5-tetrahydro-1,2,5-benzothiadiazepine;

or a pharmaceutically acceptable salt, solvate, solvate of such a salt or a prodrug thereof.

5 Further suitable IBAT inhibitors are those having the structure:

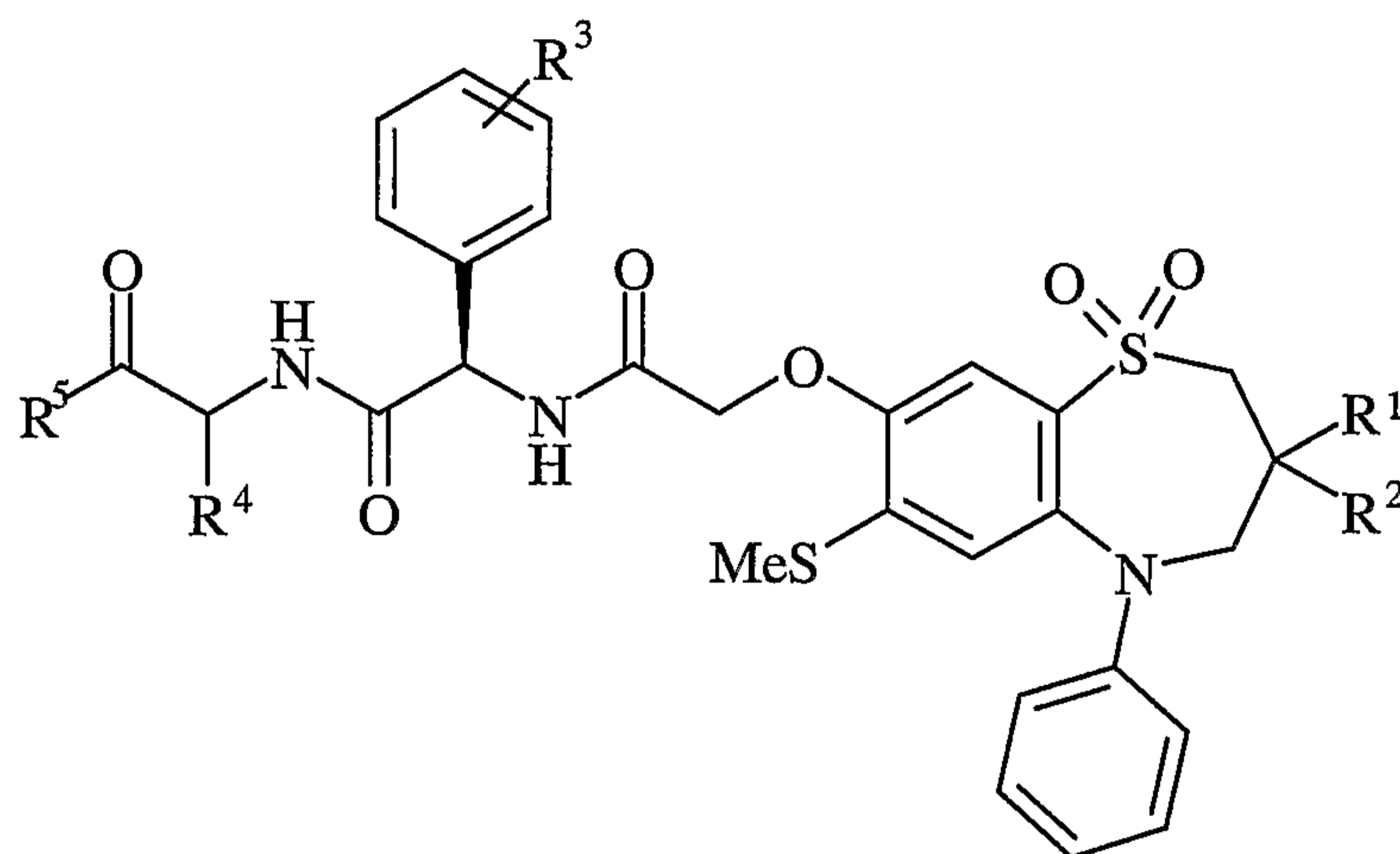

(I)

wherein:

$R^1$  and  $R^2$  are independently selected from  $C_{1-4}$ alkyl;

10  $R^3$  is hydrogen, hydroxy or halo;

$R^4$  is  $C_{1-4}$ alkyl optionally substituted by hydroxy, methoxy and methylS(O)<sub>a</sub> wherein a is 0-2

$R^5$  is hydroxy or HOC(O)CH( $R^6$ )NH-;

15  $R^6$  is selected from hydrogen and  $C_{1-3}$ alkyl optionally substituted by hydroxy, methoxy and methylS(O)<sub>a</sub> wherein a is 0-2;

or a pharmaceutically acceptable salt, solvate, solvate of such a salt or a prodrug thereof;

with the proviso that when  $R^1$  and  $R^2$  are both butyl,  $R^5$  is hydroxy and  $R^4$  is

methylthiomethyl, methylsulphinylmethyl, 2-methylthioethyl, hydroxymethyl,

methoxymethyl;  $R^3$  is not hydrogen; and with the proviso that when  $R^1$  and  $R^2$  are both butyl,

20  $R^5$  is HOC(O)CH( $R^6$ )NH-,  $R^6$  is hydroxymethyl and  $R^4$  is hydroxymethyl;  $R^3$  is not hydrogen.

Suitable IBAT inhibitors having the above structure are selected from any one of:

1,1-dioxo-3,3-dibutyl-5-phenyl-7-methylthio-8-(*N*-{(R)- $\alpha$ -[*N*'-(*S*)-1-carboxyethyl]carbamoyl]benzyl}carbamoylmethoxy)-2,3,4,5-tetrahydro-1,5-benzothiazepine;

1,1-dioxo-3,3-dibutyl-5-phenyl-7-methylthio-8-(*N*-{(R)- $\alpha$ -[*N*'-(*S*)-1-carboxypropyl]carbamoyl]benzyl}carbamoylmethoxy)-2,3,4,5-tetrahydro-1,5-benzothiazepine;

25

- 1,1-dioxo-3,3-dibutyl-5-phenyl-7-methylthio-8-(*N*-{(*R*)- $\alpha$ -[*N'*-((*S*)-1-carboxybutyl) carbamoyl]benzyl} carbamoylmethoxy)-2,3,4,5-tetrahydro-1,5-benzothiazepine;
- 1,1-dioxo-3,3-dibutyl-5-phenyl-7-methylthio-8-(*N*-{(*R*)- $\alpha$ -[*N'*-((*S*)-1-carboxy-2-methylpropyl) carbamoyl]benzyl} carbamoylmethoxy)-2,3,4,5-tetrahydro-1,5-benzothiazepine;
- 5 1,1-dioxo-3,3-dibutyl-5-phenyl-7-methylthio-8-(*N*-{(*R*)- $\alpha$ -[*N'*-((*S*)-1-carboxy-2-methylbutyl) carbamoyl]benzyl} carbamoylmethoxy)-2,3,4,5-tetrahydro-1,5-benzothiazepine;
- 1,1-dioxo-3,3-dibutyl-5-phenyl-7-methylthio-8-(*N*-{(*R*)- $\alpha$ -[*N'*-((*S*)-1-carboxy-3-methylbutyl) carbamoyl]benzyl} carbamoylmethoxy)-2,3,4,5-tetrahydro-1,5-benzothiazepine;
- 10 1,1-dioxo-3,3-dibutyl-5-phenyl-7-methylthio-8-(*N*-{(*R*)- $\alpha$ -[*N'*-((*S*)-1-carboxy-2-hydroxypropyl) carbamoyl]benzyl} carbamoylmethoxy)-2,3,4,5-tetrahydro-1,5-benzothiazepine;
- 1,1-dioxo-3,3-dibutyl-5-phenyl-7-methylthio-8-(*N*-{(*R*)- $\alpha$ -[*N'*-((*S*)-1-carboxy-2-mesylethyl) carbamoyl]benzyl} carbamoylmethoxy)-2,3,4,5-tetrahydro-1,5-benzothiazepine;
- 1,1-dioxo-3,3-dibutyl-5-phenyl-7-methylthio-8-(*N*-{(*R*)- $\alpha$ -[*N'*-((*S*)-1-carboxy-3-methylsulphonylpropyl) carbamoyl]benzyl} carbamoylmethoxy)-2,3,4,5-tetrahydro-1,5-benzothiazepine;
- 15 1,1-dioxo-3,3-dibutyl-5-phenyl-7-methylthio-8-(*N*-{(*R*)- $\alpha$ -[*N'*-((*S*)-1-carboxy-3-mesylpropyl) carbamoyl]benzyl} carbamoylmethoxy)-2,3,4,5-tetrahydro-1,5-benzothiazepine;
- 1,1-dioxo-3,3-dibutyl-5-phenyl-7-methylthio-8-(*N*-{(*R*)- $\alpha$ -[*N'*-((*S*)-1-carboxyethyl) carbamoyl]-4-hydroxybenzyl} carbamoylmethoxy)-2,3,4,5-tetrahydro-1,5-benzothiazepine;
- 20 1,1-dioxo-3,3-dibutyl-5-phenyl-7-methylthio-8-(*N*-{(*R*)- $\alpha$ -[*N'*-((*S*)-1-carboxypropyl) carbamoyl]-4-hydroxybenzyl} carbamoylmethoxy)-2,3,4,5-tetrahydro-1,5-benzothiazepine;
- 1,1-dioxo-3,3-dibutyl-5-phenyl-7-methylthio-8-(*N*-{(*R*)- $\alpha$ -[*N'*-((*S*)-1-carboxybutyl) carbamoyl]-4-hydroxybenzyl} carbamoylmethoxy)-2,3,4,5-tetrahydro-1,5-benzothiazepine;
- 25 1,1-dioxo-3,3-dibutyl-5-phenyl-7-methylthio-8-(*N*-{(*R*)- $\alpha$ -[*N'*-((*S*)-1-carboxy-2-methylpropyl) carbamoyl]-4-hydroxybenzyl} carbamoylmethoxy)-2,3,4,5-tetrahydro-1,5-benzothiazepine;
- 1,1-dioxo-3,3-dibutyl-5-phenyl-7-methylthio-8-(*N*-{(*R*)- $\alpha$ -[*N'*-((*S*)-1-carboxy-2-methylbutyl) carbamoyl]-4-hydroxybenzyl} carbamoylmethoxy)-2,3,4,5-tetrahydro-1,5-benzothiazepine;
- 30 1,1-dioxo-3,3-dibutyl-5-phenyl-7-methylthio-8-(*N*-{(*R*)- $\alpha$ -[*N'*-((*S*)-1-carboxy-3-methylbutyl) carbamoyl]-4-hydroxybenzyl} carbamoylmethoxy)-2,3,4,5-tetrahydro-1,5-

benzothiazepine;

1,1-dioxo-3,3-dibutyl-5-phenyl-7-methylthio-8-(*N*-{(*R*)- $\alpha$ -[*N'*-((*S*)-1-carboxy-2-hydroxyethyl)carbamoyl]-4-hydroxybenzyl}carbamoylethoxy)-2,3,4,5-tetrahydro-1,5-benzothiazepine;

5 1,1-dioxo-3,3-dibutyl-5-phenyl-7-methylthio-8-(*N*-{(*R*)- $\alpha$ -[*N'*-((*S*)-1-carboxy-2-hydroxypropyl)carbamoyl]-4-hydroxybenzyl}carbamoylethoxy)-2,3,4,5-tetrahydro-1,5-benzothiazepine;

1,1-dioxo-3,3-dibutyl-5-phenyl-7-methylthio-8-(*N*-{(*R*)- $\alpha$ -[*N'*-((*S*)-1-carboxy-2-methylthioethyl)carbamoyl]-4-hydroxybenzyl}carbamoylethoxy)-2,3,4,5-tetrahydro-1,5-benzothiazepine;

10 1,1-dioxo-3,3-dibutyl-5-phenyl-7-methylthio-8-(*N*-{(*R*)- $\alpha$ -[*N'*-((*S*)-1-carboxy-2-methylsulphinyethyl)carbamoyl]-4-hydroxybenzyl}carbamoylethoxy)-2,3,4,5-tetrahydro-1,5-benzothiazepine;

15 1,1-dioxo-3,3-dibutyl-5-phenyl-7-methylthio-8-(*N*-{(*R*)- $\alpha$ -[*N'*-((*S*)-1-carboxy-2-mesyethyl)carbamoyl]-4-hydroxybenzyl}carbamoylethoxy)-2,3,4,5-tetrahydro-1,5-benzothiazepine;

1,1-dioxo-3,3-dibutyl-5-phenyl-7-methylthio-8-(*N*-{(*R*)- $\alpha$ -[*N'*-((*S*)-1-carboxy-2-methoxyethyl)carbamoyl]-4-hydroxybenzyl}carbamoylethoxy)-2,3,4,5-tetrahydro-1,5-benzothiazepine;

20 1,1-dioxo-3,3-dibutyl-5-phenyl-7-methylthio-8-(*N*-{(*R*)- $\alpha$ -[*N'*-((*S*)-1-carboxy-3-methylthiopropyl)carbamoyl]-4-hydroxybenzyl}carbamoylethoxy)-2,3,4,5-tetrahydro-1,5-benzothiazepine;

1,1-dioxo-3,3-dibutyl-5-phenyl-7-methylthio-8-(*N*-{(*R*)- $\alpha$ -[*N'*-((*S*)-1-carboxy-3-methylsulphonylpropyl)carbamoyl]-4-hydroxybenzyl}carbamoylethoxy)-2,3,4,5-tetrahydro-1,5-benzothiazepine; or

1,1-dioxo-3,3-dibutyl-5-phenyl-7-methylthio-8-(*N*-{(*R*)- $\alpha$ -[*N'*-((*S*)-1-carboxy-3-mesylpropyl)carbamoyl]-4-hydroxybenzyl}carbamoylethoxy)-2,3,4,5-tetrahydro-1,5-benzothiazepine;

or a pharmaceutically acceptable salt, solvate, solvate of such a salt or a prodrug thereof.

30 Additional suitable IBAT inhibitors having the above structure are selected from:

- 20 -

1,1-dioxo-3,3-dibutyl-5-phenyl-7-methylthio-8-(*N*-{(*R*)- $\alpha$ -[*N'*-((*S*)-1-carboxypropyl)carbamoyl]-4-hydroxybenzyl}carbamoylmethoxy)-2,3,4,5-tetrahydro-1,5-benzothiazepine; or

5 1,1-dioxo-3,3-dibutyl-5-phenyl-7-methylthio-8-(*N*-{(*R*)- $\alpha$ -[*N'*-((*S*)-1-carboxyethyl)carbamoyl]benzyl}carbamoylmethoxy)-2,3,4,5-tetrahydro-1,5-benzothiazepine.

Further suitable IBAT inhibitors are those having the structure:

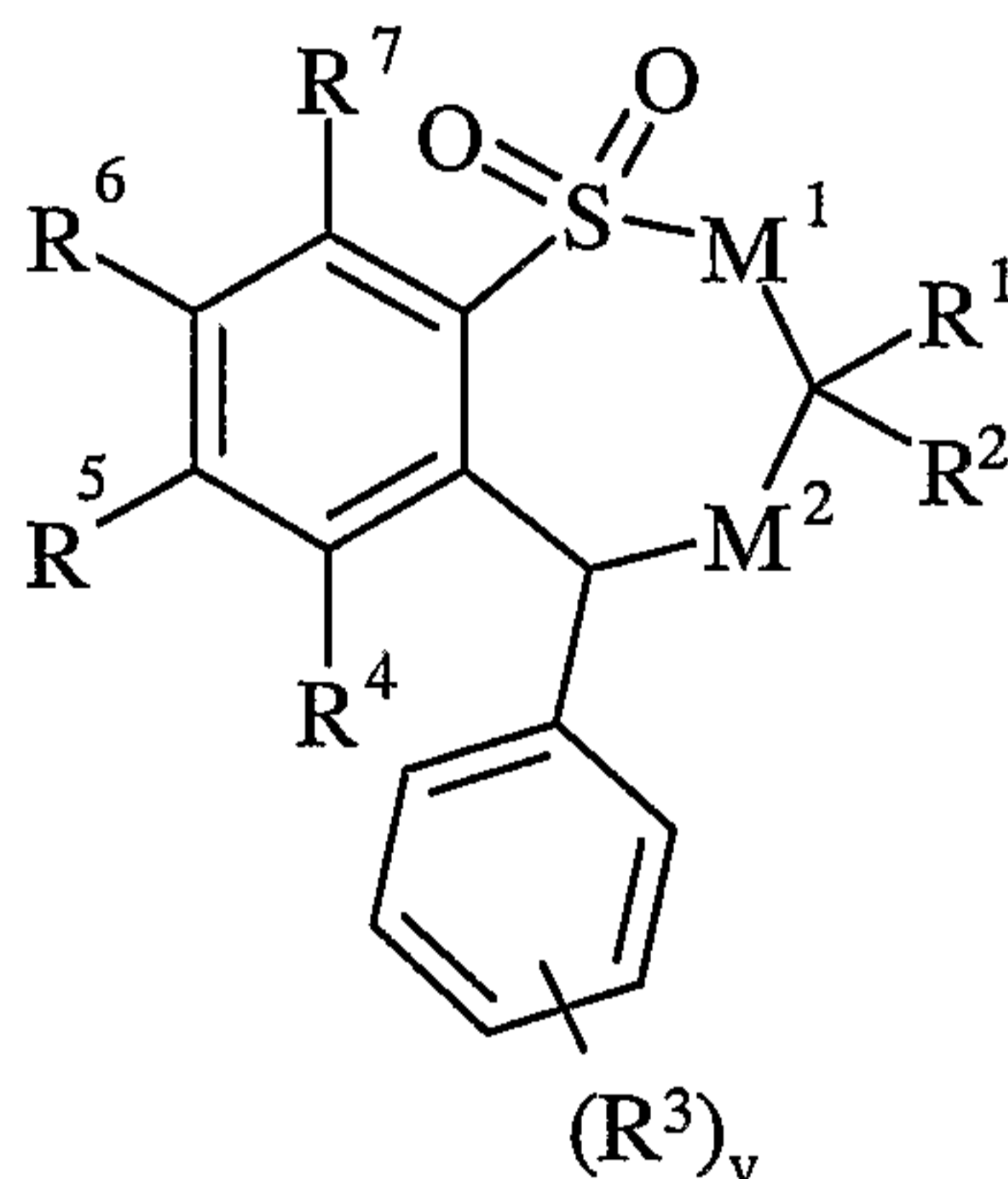

(I)

wherein

10  $M^1$  is  $-CH_2-$  or  $-NR^{21}-$ ;

$M^2$  is  $-CR^{22}R^{23}-$  or  $-NR^{24}-$ ; provided that if  $M^1$  is  $-NR^{21}-$ ,  $M^2$  is  $-CR^{22}R^{23}-$ ;

One of  $R^1$  and  $R^2$  are selected from hydrogen,  $C_{1-6}$ alkyl or  $C_{2-6}$ alkenyl and the other is selected from  $C_{1-6}$ alkyl or  $C_{2-6}$ alkenyl;

15  $R^3$  is selected from halo, nitro, cyano, hydroxy, amino, carboxy, carbamoyl, mercapto, sulphamoyl,  $C_{1-6}$ alkyl,  $C_{2-6}$ alkenyl,  $C_{2-6}$ alkynyl,  $C_{1-6}$ alkoxy,  $C_{1-6}$ alkanoyl,  $C_{1-6}$ alkanoyloxy,  $N$ -( $C_{1-6}$ alkyl)amino,  $N,N$ -( $C_{1-6}$ alkyl) $_2$ amino,  $C_{1-6}$ alkanoylamino,  $N$ -( $C_{1-6}$ alkyl)carbamoyl,  $N,N$ -( $C_{1-6}$ alkyl) $_2$ carbamoyl,  $C_{1-6}$ alkylS(O) $_a$  wherein  $a$  is 0 to 2,  $C_{1-6}$ alkoxycarbonyl,  $N$ -( $C_{1-6}$ alkyl)sulphamoyl and  $N,N$ -( $C_{1-6}$ alkyl) $_2$ sulphamoyl;

$v$  is 0-5;

20 one of  $R^5$  and  $R^6$  is a group of formula (IA):

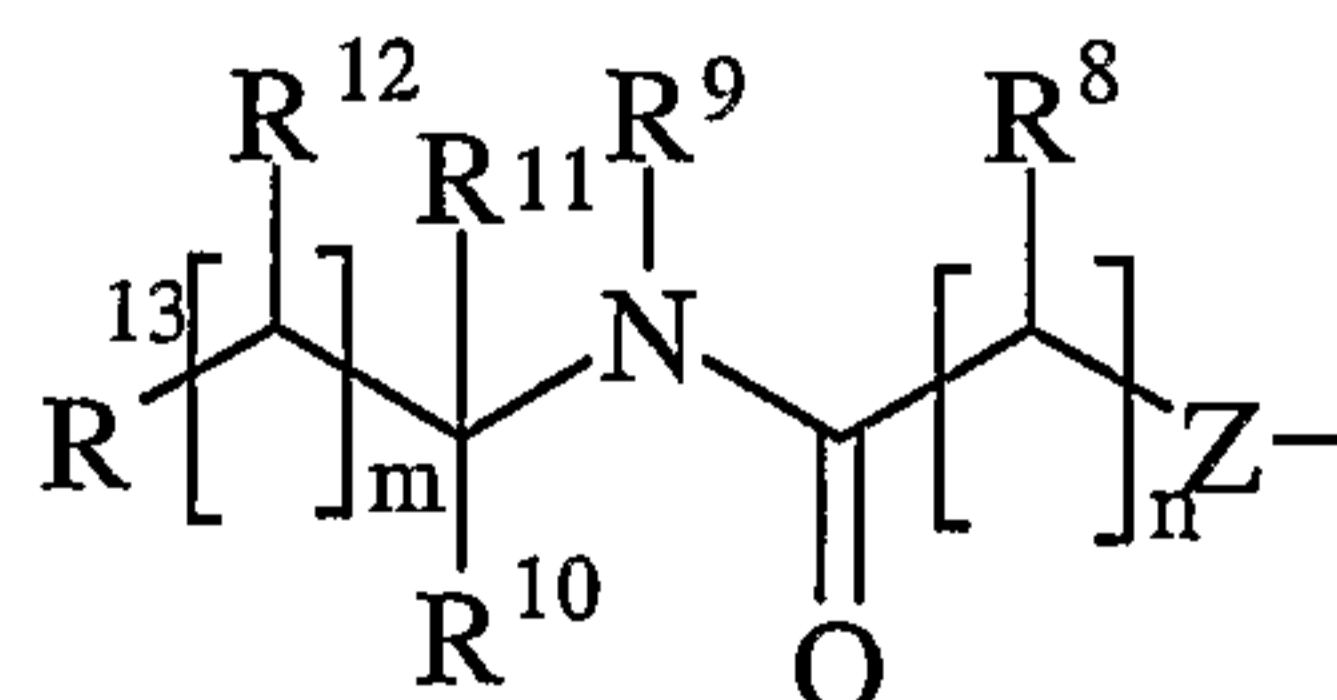

(IA)

- 21 -

**R<sup>4</sup>** and **R<sup>7</sup>** and the other of **R<sup>5</sup>** and **R<sup>6</sup>** are independently selected from hydrogen, halo, nitro, cyano, hydroxy, amino, carboxy, carbamoyl, mercapto, sulphamoyl, C<sub>1-4</sub>alkyl, C<sub>2-4</sub>alkenyl, C<sub>2-4</sub>alkynyl, C<sub>1-4</sub>alkoxy, C<sub>1-4</sub>alkanoyl, C<sub>1-4</sub>alkanoyloxy, *N*-(C<sub>1-4</sub>alkyl)amino, *N,N*-(C<sub>1-4</sub>alkyl)<sub>2</sub>amino, C<sub>1-4</sub>alkanoylamino, *N*-(C<sub>1-4</sub>alkyl)carbamoyl, *N,N*-(C<sub>1-4</sub>alkyl)<sub>2</sub>carbamoyl, C<sub>1-4</sub>alkylS(O)<sub>a</sub> wherein a is 0 to 2, C<sub>1-4</sub>alkoxycarbonyl, *N*-(C<sub>1-4</sub>alkyl)sulphamoyl and *N,N*-(C<sub>1-4</sub>alkyl)<sub>2</sub>sulphamoyl; wherein **R<sup>4</sup>** and **R<sup>7</sup>** and the other of **R<sup>5</sup>** and **R<sup>6</sup>** may be optionally substituted on carbon by one or more **R<sup>25</sup>**;

**Z** is -O-, -N(R<sup>a</sup>)-, -S(O)<sub>b</sub>- or -CH(R<sup>a</sup>)-; wherein R<sup>a</sup> is hydrogen or C<sub>1-6</sub>alkyl and b is 0-2;

**R<sup>8</sup>** is hydrogen, C<sub>1-4</sub>alkyl, carbocyclyl or heterocyclyl; wherein **R<sup>8</sup>** may be optionally substituted on carbon by one or more substituents selected from **R<sup>26</sup>**; and wherein if said heterocyclyl contains an -NH- group, that nitrogen may be optionally substituted by a group selected from **R<sup>27</sup>**;

**R<sup>9</sup>** is hydrogen or C<sub>1-4</sub>alkyl;

**R<sup>10</sup>** and **R<sup>11</sup>** are independently selected from hydrogen, C<sub>1-4</sub>alkyl, carbocyclyl or heterocyclyl; or **R<sup>10</sup>** and **R<sup>11</sup>** together form C<sub>2-6</sub>alkylene; wherein **R<sup>10</sup>** and **R<sup>11</sup>** or **R<sup>10</sup>** and **R<sup>11</sup>** together may be independently optionally substituted on carbon by one or more substituents selected from **R<sup>28</sup>**; and wherein if said heterocyclyl contains an -NH- moiety, that nitrogen may be optionally substituted by one or more **R<sup>29</sup>**;

**R<sup>12</sup>** is hydrogen, C<sub>1-4</sub>alkyl, carbocyclyl or heterocyclyl; wherein **R<sup>12</sup>** may be optionally substituted on carbon by one or more substituents selected from **R<sup>30</sup>**; and wherein if said heterocyclyl contains an -NH- moiety, that nitrogen may be optionally substituted by one or more **R<sup>31</sup>**;

**R<sup>13</sup>** is hydrogen, halo, nitro, cyano, hydroxy, amino, carbamoyl, mercapto, sulphamoyl, hydroxyaminocarbonyl, C<sub>1-10</sub>alkyl, C<sub>2-10</sub>alkenyl, C<sub>2-10</sub>alkynyl, C<sub>1-10</sub>alkoxy, C<sub>1-10</sub>alkoxycarbonyl, C<sub>1-10</sub>alkanoyl, C<sub>1-10</sub>alkanoyloxy, *N*-(C<sub>1-10</sub>alkyl)amino, *N,N*-(C<sub>1-10</sub>alkyl)<sub>2</sub>amino, *N,N,N*-(C<sub>1-10</sub>alkyl)<sub>3</sub>ammonio, C<sub>1-10</sub>alkanoylamino, *N*-(C<sub>1-10</sub>alkyl)carbamoyl, *N,N*-(C<sub>1-10</sub>alkyl)<sub>2</sub>carbamoyl, C<sub>1-10</sub>alkylS(O)<sub>a</sub> wherein a is 0 to 2, *N*-(C<sub>1-10</sub>alkyl)sulphamoyl, *N,N*-(C<sub>1-10</sub>alkyl)<sub>2</sub>sulphamoyl, *N*-(C<sub>1-10</sub>alkyl)sulphamoylamino, *N,N*-(C<sub>1-10</sub>alkyl)<sub>2</sub>sulphamoylamino, C<sub>1-10</sub>alkoxycarbonylamino, carbocyclyl, carbocyclylC<sub>1-10</sub>alkyl, heterocyclic group, heterocyclylC<sub>1-10</sub>alkyl, carbocyclyl-(C<sub>1-10</sub>alkylene)<sub>e</sub>-**R<sup>32</sup>**-(C<sub>1-10</sub>alkylene)<sub>f</sub> or

- 22 -

heterocyclyl-(C<sub>1-10</sub>alkylene)<sub>g</sub>-R<sup>33</sup>-(C<sub>1-10</sub>alkylene)<sub>h</sub>; wherein R<sup>13</sup> may be optionally substituted on carbon by one or more substituents selected from R<sup>36</sup>; and wherein if said heterocyclyl contains an -NH- group, that nitrogen may be optionally substituted by a group selected from R<sup>37</sup>; or R<sup>13</sup> is a group of formula (IB):

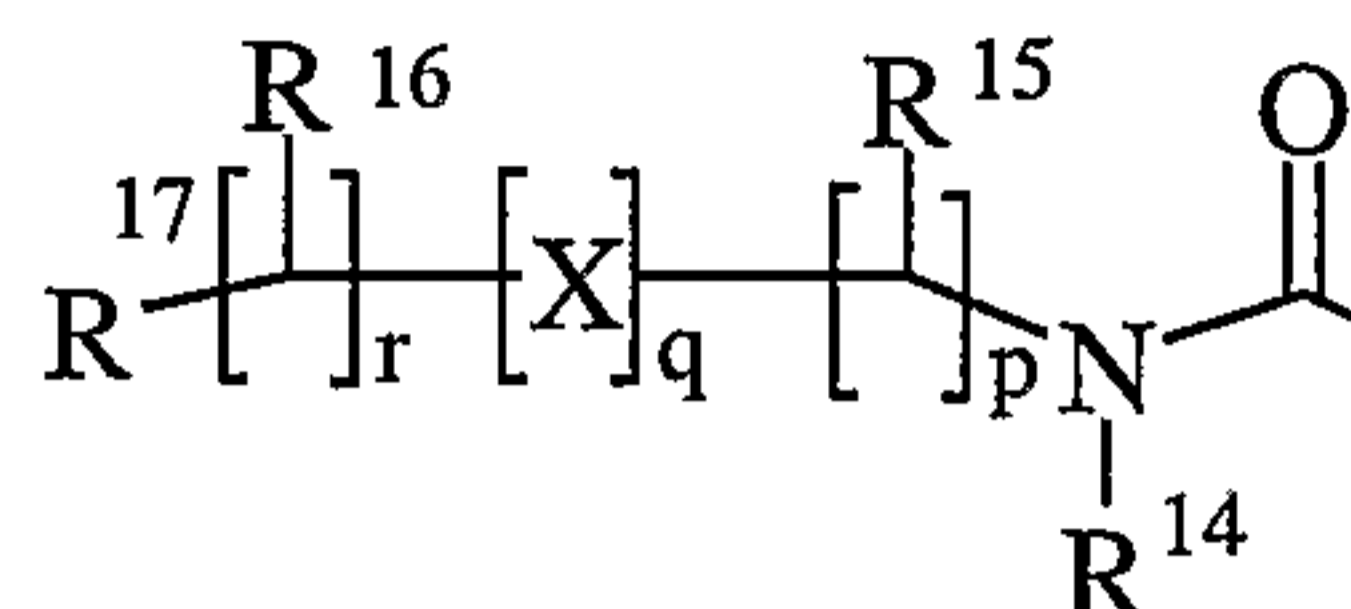

5

(IB)

wherein:

X is -N(R<sup>38</sup>)-, -N(R<sup>38</sup>)C(O)-, -O-, and -S(O)<sub>a</sub>-; wherein a is 0-2 and R<sup>38</sup> is hydrogen or C<sub>1-4</sub>alkyl;

10 R<sup>14</sup> is hydrogen or C<sub>1-4</sub>alkyl;

R<sup>15</sup> and R<sup>16</sup> are independently selected from hydrogen, halo, nitro, cyano, hydroxy, amino, carbamoyl, mercapto, sulphamoyl, C<sub>1-6</sub>alkyl, C<sub>2-6</sub>alkenyl, C<sub>2-6</sub>alkynyl, C<sub>1-6</sub>alkoxy, C<sub>1-6</sub>alkanoyl, C<sub>1-6</sub>alkanoyloxy, N-(C<sub>1-6</sub>alkyl)amino, N,N-(C<sub>1-6</sub>alkyl)<sub>2</sub>amino, C<sub>1-6</sub>alkanoylamino, N-(C<sub>1-6</sub>alkyl)carbamoyl, N,N-(C<sub>1-6</sub>alkyl)<sub>2</sub>carbamoyl, C<sub>1-6</sub>alkylS(O)<sub>a</sub> wherein a is 0 to 2, C<sub>1-6</sub>alkoxycarbonyl, N-(C<sub>1-6</sub>alkyl)sulphamoyl, N,N-(C<sub>1-6</sub>alkyl)<sub>2</sub>sulphamoyl, carbocyclyl or heterocyclic group; wherein R<sup>15</sup> and R<sup>16</sup> may be independently optionally substituted on carbon by one or more substituents selected from R<sup>41</sup>; and wherein if said heterocyclyl contains an -NH- group, that nitrogen may be optionally substituted by a group selected from R<sup>42</sup>;

20 R<sup>17</sup> is selected from hydrogen, halo, nitro, cyano, hydroxy, amino, carbamoyl, mercapto, sulphamoyl, hydroxyaminocarbonyl, C<sub>1-10</sub>alkyl, C<sub>2-10</sub>alkenyl, C<sub>2-10</sub>alkynyl, C<sub>1-10</sub>alkoxy, C<sub>1-10</sub>alkanoyl, C<sub>1-10</sub>alkanoyloxy, N-(C<sub>1-10</sub>alkyl)amino, N,N-(C<sub>1-10</sub>alkyl)<sub>2</sub>amino, C<sub>1-10</sub>alkanoylamino, N-(C<sub>1-10</sub>alkyl)carbamoyl, C<sub>1-10</sub>alkoxycarbonyl, N,N-(C<sub>1-10</sub>alkyl)<sub>2</sub>carbamoyl, C<sub>1-10</sub>alkylS(O)<sub>a</sub> wherein a is 0 to 2, N-(C<sub>1-10</sub>alkyl)sulphamoyl, 25 N,N-(C<sub>1-10</sub>alkyl)<sub>2</sub>sulphamoyl, N-(C<sub>1-10</sub>alkyl)sulphamoylamino, N,N-(C<sub>1-10</sub>alkyl)<sub>2</sub>sulphamoylamino, carbocyclyl, carbocyclylC<sub>1-10</sub>alkyl, heterocyclic group, heterocyclylC<sub>1-10</sub>alkyl, carbocyclyl-(C<sub>1-10</sub>alkylene)<sub>e</sub>-R<sup>43</sup>-(C<sub>1-10</sub>alkylene)<sub>f</sub> or heterocyclyl-(C<sub>1-10</sub>alkylene)<sub>g</sub>-R<sup>44</sup>-(C<sub>1-10</sub>alkylene)<sub>h</sub>; wherein R<sup>17</sup> may be optionally substituted on carbon by one or more substituents selected from R<sup>47</sup>; and wherein if said heterocyclyl

- 23 -

contains an -NH- group, that nitrogen may be optionally substituted by a group selected from  $R^{48}$ ; or  $R^{17}$  is a group of formula (IC):

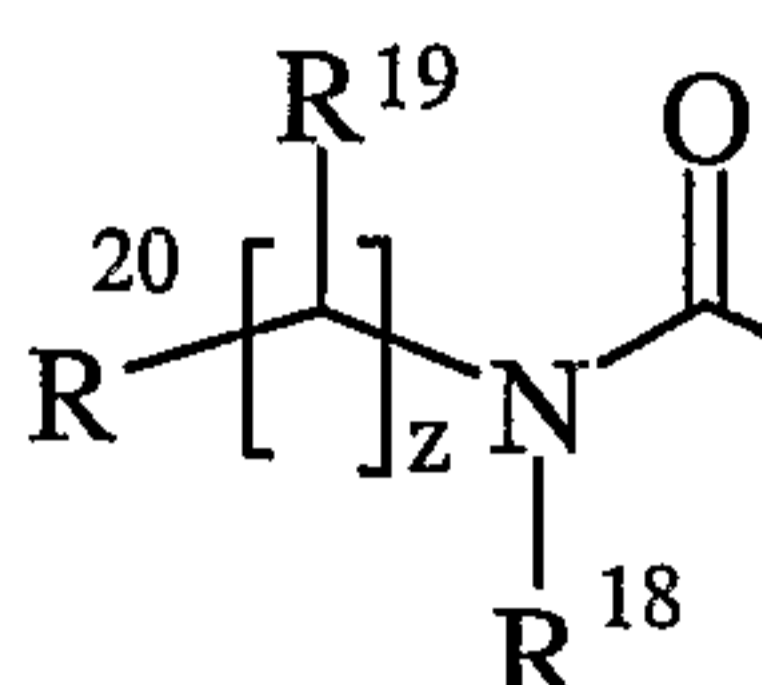

(IC)

5 wherein:

$R^{18}$  is selected from hydrogen or  $C_{1-4}$ alkyl;

$R^{19}$  is selected from hydrogen, halo, nitro, cyano, hydroxy, amino, carbamoyl, mercapto, sulphamoyl,  $C_{1-6}$ alkyl,  $C_{2-6}$ alkenyl,  $C_{2-6}$ alkynyl,  $C_{1-6}$ alkoxy,  $C_{1-6}$ alkanoyl,  $C_{1-6}$ alkanoyloxy,  $N$ -( $C_{1-6}$ alkyl)amino,  $N,N$ -( $C_{1-6}$ alkyl)<sub>2</sub>amino,  $C_{1-6}$ alkanoylamino,   
 10  $N$ -( $C_{1-6}$ alkyl)carbamoyl,  $N,N$ -( $C_{1-6}$ alkyl)<sub>2</sub>carbamoyl,  $C_{1-6}$ alkylS(O)<sub>a</sub> wherein a is 0 to 2,  $C_{1-6}$ alkoxycarbonyl,  $N$ -( $C_{1-6}$ alkyl)sulphamoyl,  $N,N$ -( $C_{1-6}$ alkyl)<sub>2</sub>sulphamoyl, carbocyclyl or heterocyclic group; where  $R^{19}$  may be independently optionally substituted on carbon by one or more substituents selected from  $R^{51}$ ; and wherein if said heterocyclyl contains an -NH- group, that nitrogen may be optionally substituted by a group selected from  $R^{52}$ ;

15  $R^{20}$  is selected from halo, nitro, cyano, hydroxy, amino, carbamoyl, mercapto, sulphamoyl, hydroxyaminocarbonyl,  $C_{1-10}$ alkyl,  $C_{2-10}$ alkenyl,  $C_{2-10}$ alkynyl,  $C_{1-10}$ alkoxy,  $C_{1-10}$ alkoxycarbonyl,  $C_{1-10}$ alkanoyl,  $C_{1-10}$ alkanoyloxy,  $N$ -( $C_{1-10}$ alkyl)amino,  $N,N$ -( $C_{1-10}$ alkyl)<sub>2</sub>amino,  $N,N,N$ -( $C_{1-10}$ alkyl)<sub>3</sub>ammonio,  $C_{1-10}$ alkanoylamino,  $N$ -( $C_{1-10}$ alkyl)carbamoyl,  $N,N$ -( $C_{1-10}$ alkyl)<sub>2</sub>carbamoyl,  $C_{1-10}$ alkylS(O)<sub>a</sub> wherein a is 0 to 2,   
 20  $N$ -( $C_{1-10}$ alkyl)sulphamoyl,  $N,N$ -( $C_{1-10}$ alkyl)<sub>2</sub>sulphamoyl,  $N$ -( $C_{1-10}$ alkyl)sulphamoylamino,  $N,N$ -( $C_{1-10}$ alkyl)<sub>2</sub>sulphamoylamino,  $C_{1-10}$ alkoxycarbonylamino, carbocyclyl, carbocyclyl $C_{1-10}$ alkyl, heterocyclic group, heterocyclyl $C_{1-10}$ alkyl, carbocyclyl-( $C_{1-10}$ alkylene)<sub>e</sub>- $R^{53}$ -( $C_{1-10}$ alkylene)<sub>f</sub>- or heterocyclyl-( $C_{1-10}$ alkylene)<sub>g</sub>- $R^{54}$ -( $C_{1-10}$ alkylene)<sub>h</sub>-; wherein  $R^{20}$  may be independently   
 25 optionally substituted on carbon by one or more  $R^{57}$ ; and wherein if said heterocyclyl contains an -NH- group, that nitrogen may be optionally substituted by a group selected from  $R^{58}$ ;

$p$  is 1-3; wherein the values of  $R^{15}$  may be the same or different;

$q$  is 0-1;

$r$  is 0-3; wherein the values of  $R^{16}$  may be the same or different;

30  $m$  is 0-2; wherein the values of  $R^{12}$  may be the same or different;

- 24 -

**n** is 1-2; wherein the values of  $R^8$  may be the same or different;

**z** is 0-3; wherein the values of  $R^{19}$  may be the same or different;

$R^{21}$  is selected from hydrogen or  $C_{1-6}$ alkyl;

$R^{22}$  and  $R^{23}$  are independently selected from hydrogen, hydroxy, amino, mercapto,  
 5  $C_{1-6}$ alkyl,  $C_{1-6}$ alkoxy,  $N$ -( $C_{1-6}$ alkyl)amino,  $N,N$ -( $C_{1-6}$ alkyl)<sub>2</sub>amino,  $C_{1-6}$ alkylS(O)<sub>a</sub> wherein a is  
 0 to 2;

$R^{24}$  is selected from hydrogen, hydroxy,  $C_{1-6}$ alkyl,  $C_{1-4}$ alkoxy and  $C_{1-6}$ alkanoyloxy;

$R^{25}$  is selected from halo, nitro, cyano, hydroxy, amino, carboxy, carbamoyl, mercapto,  
 sulphamoyl,  $C_{1-4}$ alkyl,  $C_{2-4}$ alkenyl,  $C_{2-4}$ alkynyl,  $C_{1-4}$ alkoxy,  $C_{1-4}$ alkanoyl,  $C_{1-4}$ alkanoyloxy,  
 10  $N$ -( $C_{1-4}$ alkyl)amino,  $N,N$ -( $C_{1-4}$ alkyl)<sub>2</sub>amino,  $C_{1-4}$ alkanoylamino,  $N$ -( $C_{1-4}$ alkyl)carbamoyl,  
 $N,N$ -( $C_{1-4}$ alkyl)<sub>2</sub>carbamoyl,  $C_{1-4}$ alkylS(O)<sub>a</sub> wherein a is 0 to 2,  $C_{1-4}$ alkoxycarbonyl,  
 $N$ -( $C_{1-4}$ alkyl)sulphamoyl and  $N,N$ -( $C_{1-4}$ alkyl)<sub>2</sub>sulphamoyl; wherein  $R^{25}$ , may be independently  
 optionally substituted on carbon by one or more  $R^{67}$ ;

$R^{26}$ ,  $R^{28}$ ,  $R^{30}$ ,  $R^{36}$ ,  $R^{41}$ ,  $R^{47}$ ,  $R^{51}$  and  $R^{57}$  are independently selected from halo, nitro,  
 15 cyano, hydroxy, amino, carbamoyl, mercapto, sulphamoyl, hydroxyaminocarbonyl,  $C_{1-10}$ alkyl,  
 $C_{2-10}$ alkenyl,  $C_{2-10}$ alkynyl,  $C_{1-10}$ alkoxy,  $C_{1-10}$ alkanoyl,  $C_{1-10}$ alkanoyloxy,  $C_{1-10}$ alkoxycarbonyl,  
 $N$ -( $C_{1-10}$ alkyl)amino,  $N,N$ -( $C_{1-10}$ alkyl)<sub>2</sub>amino,  $N,N,N$ -( $C_{1-10}$ alkyl)<sub>3</sub>ammonio,  
 $C_{1-10}$ alkanoylamino,  $N$ -( $C_{1-10}$ alkyl)carbamoyl,  $N,N$ -( $C_{1-10}$ alkyl)<sub>2</sub>carbamoyl,  $C_{1-10}$ alkylS(O)<sub>a</sub>  
 wherein a is 0 to 2,  $N$ -( $C_{1-10}$ alkyl)sulphamoyl,  $N,N$ -( $C_{1-10}$ alkyl)<sub>2</sub>sulphamoyl,  
 20  $N$ -( $C_{1-10}$ alkyl)sulphamoylamino,  $N,N$ -( $C_{1-10}$ alkyl)<sub>2</sub>sulphamoylamino,  
 $C_{1-10}$ alkoxycarbonylamino, carbocyclyl, carbocyclyl $C_{1-10}$ alkyl, heterocyclic group,  
 heterocyclyl $C_{1-10}$ alkyl, carbocyclyl-( $C_{1-10}$ alkylene)<sub>e</sub>- $R^{59}$ -( $C_{1-10}$ alkylene)<sub>f</sub>- or  
 heterocyclyl-( $C_{1-10}$ alkylene)<sub>g</sub>- $R^{60}$ -( $C_{1-10}$ alkylene)<sub>h</sub>-; wherein  $R^{26}$ ,  $R^{28}$ ,  $R^{30}$ ,  $R^{36}$ ,  $R^{41}$ ,  $R^{47}$ ,  $R^{51}$   
 and  $R^{57}$  may be independently optionally substituted on carbon by one or more  $R^{63}$ ; and  
 25 wherein if said heterocyclyl contains an -NH- group, that nitrogen may be optionally  
 substituted by a group selected from  $R^{64}$ ;

$R^{27}$ ,  $R^{29}$ ,  $R^{31}$ ,  $R^{37}$ ,  $R^{42}$ ,  $R^{48}$ ,  $R^{52}$ ,  $R^{58}$  and  $R^{64}$  are independently selected from  
 $C_{1-6}$ alkyl,  $C_{1-6}$ alkanoyl,  $C_{1-6}$ alkylsulphonyl, sulphamoyl,  $N$ -( $C_{1-6}$ alkyl)sulphamoyl,  
 $N,N$ -( $C_{1-6}$ alkyl)<sub>2</sub>sulphamoyl,  $C_{1-6}$ alkoxycarbonyl, carbamoyl,  $N$ -( $C_{1-6}$ alkyl)carbamoyl,  
 30  $N,N$ -( $C_{1-6}$ alkyl)<sub>2</sub>carbamoyl, benzyl, phenethyl, benzoyl, phenylsulphonyl and phenyl;

- 25 -

$R^{32}$ ,  $R^{33}$ ,  $R^{43}$ ,  $R^{44}$ ,  $R^{53}$ ,  $R^{54}$ ,  $R^{59}$  and  $R^{60}$  are independently selected from -O-, -NR<sup>65</sup>-, -S(O)<sub>x</sub>-, -NR<sup>65</sup>C(O)NR<sup>66</sup>-, -NR<sup>65</sup>C(S)NR<sup>66</sup>-, -OC(O)N=C-, -NR<sup>65</sup>C(O)- or -C(O)NR<sup>65</sup>-; wherein  $R^{65}$  and  $R^{66}$  are independently selected from hydrogen or C<sub>1-6</sub>alkyl, and x is 0-2;

$R^{63}$  and  $R^{67}$  are independently selected from halo, hydroxy, cyano, carbamoyl, ureido, amino, nitro, carbamoyl, mercapto, sulphamoyl, trifluoromethyl, trifluoromethoxy, methyl, ethyl, methoxy, ethoxy, vinyl, allyl, ethynyl, methoxycarbonyl, formyl, acetyl, formamido, acetylamino, acetoxy, methylamino, dimethylamino, *N*-methylcarbamoyl, *N,N*-dimethylcarbamoyl, methylthio, methylsulphinyl, mesyl, *N*-methylsulphamoyl and *N,N*-dimethylsulphamoyl; and

**e**, **f**, **g** and **h** are independently selected from 0-2;

or a pharmaceutically acceptable salt, solvate, solvate of such a salt or a prodrug thereof.

Additional suitable IBAT inhibitors having the above structure are selected from any one of:

(+/-)-trans-1,1-dioxo-3-ethyl-3-butyl-5-phenyl-7-methylthio-8-(*N*-{(R)- $\alpha$ -[*N'*-(2-(S)-3-(R)-4-(R)-5-(R)-2,3,4,5,6-pentahydroxyhexyl)carbamoyl]benzyl}carbamoylmethoxy)-2,3,4,5-tetrahydro-1,4-benzothiazepine;

(+/-)-trans-1,1-dioxo-3-ethyl-3-butyl-5-phenyl-7-methylthio-8-(*N*-{(R)- $\alpha$ -[*N'*-(2-(S)-3-(R)-4-(R)-5-(R)-2,3,4,5,6-pentahydroxyhexyl)carbamoyl]benzyl}carbamoylmethoxy)-2,3,4,5-tetrahydro-1,4-benzothiazepine;

1,1-dioxo-3-ethyl-3-butyl-4-hydroxy-5-phenyl-7-(*N*-{ $\alpha$ -[*N'*-(2-(S)-3-(R)-4-(R)-5-(R)-2,3,4,5,6-pentahydroxyhexyl)carbamoyl]-2-fluorobenzyl}carbamoylmethylthio)-2,3,4,5-tetrahydrobenzothiazepine; or

1,1-dioxo-3-butyl-3-ethyl-4-hydroxy-5-phenyl-7-(*N*-{1-[*N'*-(2-(S)-3-(R)-4-(R)-5-(R)-2,3,4,5,6-pentahydroxyhexyl)carbamoyl]-1-(cyclohexyl)methyl}carbamoylmethylthio)-2,3,4,5-tetrahydrobenzothiazepine.

In a particular aspect of the invention an IBAT inhibitor or a pharmaceutically acceptable salt, solvate, solvate of such a salt or a prodrug thereof is an IBAT inhibitor or a pharmaceutically acceptable salt thereof.

Suitable pharmaceutically acceptable salts of the above compounds are, for example, an acid-addition salt of a compound of the invention which is sufficiently basic, for example, an acid-addition salt with, for example, an inorganic or organic acid, for example hydrochloric, hydrobromic, sulphuric, phosphoric, trifluoroacetic, citric, acetate or maleic

acid. In addition a suitable pharmaceutically acceptable salt of a compound which is sufficiently acidic is an alkali metal salt, for example a sodium or potassium salt, an alkaline earth metal salt, for example a calcium or magnesium salt, an ammonium salt or a salt with an organic base which affords a physiologically-acceptable cation, for example a salt with  
5 methylamine, dimethylamine, trimethylamine, piperidine, morpholine or tris-(2-hydroxyethyl)amine.

The compounds may be administered in the form of a pro-drug which is broken down in the human or animal body to give the parent compound. Examples of pro-drugs include *in vivo* hydrolysable esters and *in vivo* hydrolysable amides.

10 An *in vivo* hydrolysable ester of a compound containing carboxy or hydroxy group is, for example, a pharmaceutically acceptable ester which is hydrolysed in the human or animal body to produce the parent acid or alcohol. Suitable pharmaceutically acceptable esters for carboxy include C<sub>1-6</sub>alkoxymethyl esters for example methoxymethyl, C<sub>1-6</sub>alkanoyloxymethyl esters for example pivaloyloxymethyl, phthalidyl esters, C<sub>3-8</sub>cycloalkoxycarbonyloxyC<sub>1-6</sub>alkyl  
15 esters for example 1-cyclohexylcarbonyloxyethyl; 1,3-dioxolen-2-onylmethyl esters for example 5-methyl-1,3-dioxolen-2-onylmethyl; and C<sub>1-6</sub>alkoxycarbonyloxyethyl esters for example 1-methoxycarbonyloxyethyl and may be formed at any carboxy group in the compounds.

An *in vivo* hydrolysable ester of a compound containing a hydroxy group includes  
20 inorganic esters such as phosphate esters and  $\alpha$ -acyloxyalkyl ethers and related compounds which as a result of the *in vivo* hydrolysis of the ester breakdown to give the parent hydroxy group. Examples of  $\alpha$ -acyloxyalkyl ethers include acetoxymethoxy and 2,2-dimethylpropionyloxy-methoxy. A selection of *in vivo* hydrolysable ester forming groups for hydroxy include alkanoyl, benzoyl, phenylacetyl and substituted benzoyl and phenylacetyl,  
25 alkoxycarbonyl (to give alkyl carbonate esters), dialkylcarbamoyle and *N*-(dialkylaminoethyl)-*N*-alkylcarbamoyle (to give carbamates), dialkylaminoacetyl and carboxyacetyl. Examples of substituents on benzoyl include morpholino and piperazino linked from a ring nitrogen atom via a methylene group to the 3- or 4- position of the benzoyl ring.

A suitable value for an *in vivo* hydrolysable amide of a compound containing a  
30 carboxy group is, for example, a *N*-C<sub>1-6</sub>alkyl or *N,N*-di-C<sub>1-6</sub>alkyl amide such as *N*-methyl, *N*-ethyl, *N*-propyl, *N,N*-dimethyl, *N*-ethyl-*N*-methyl or *N,N*-diethyl amide.

**Experimental**

As stated hereinbefore the compounds defined in the present invention are useful in the treatment of functional constipation and C-IBS. These properties may be assessed, for example, using models known in the art:

- 5       ➤ Buenos dog model for constipation, (Hepato-gastroenterology, 1980, 27, 381-389). Here dogs are fed with a low fibre / high protein diet to induce constipation;
- Niwa's morphine induced constipation model (Bioscience Biotechnology and Biochemistry, 2002, 66, 6, 1233-1240); and
- Removal of the caecum in rats has also been demonstrated to induce constipation.

10       Once constipation has been induced the animals can be dosed with an IBAT inhibitor to assess the ability of the IBAT inhibitor to relieve the constipation.

The following data was generated using the Buenos dog model (method described in the publication above) with the modification that the dogs were given 20 g meat/kg dog /day. The result is calculated as mean value of the increase of faeces during the three treatment days subtracted with the entry value (day before start of treatment with the IBAT inhibitor). The dogs were judge as constipation if there faeces amount per day was below 30 gram.

1) Compound 1: 1,1-Dioxo-3,3-dibutyl-5-phenyl-7-methylthio-8-(N-{(R)- $\alpha$ -[N-(2-sulphoethyl)carbamoyl]-4-hydroxybenzyl}carbamoylmethoxy)-2,3,4,5-tetrahydro-1,2,5-benzothiadiazepine

Substance dosed	No of animals	Dose $\mu\text{mol/kg}$	Result
Compound 1	3	5	38 $\pm$ 7 *
vehicle only	3	0	0 $\pm$ 7

\* Significance  $\leq 0.01$

2) Compound 2: 1,1-Dioxo-3,3-dibutyl-5-phenyl-7-methylthio-8-(N-{(R)- $\alpha$ -[N-((S)-1-carboxy-2-(R)-hydroxypropyl)carbamoyl]-4-hydroxybenzyl}carbamoylmethoxy)-2,3,4,5-tetrahydro-1,2,5-benzothiadiazepine

Substance dosed	No of animals	Dose $\mu\text{mol/kg}$	Result
Compound 2	2	1.5	23 $\pm$ 11
vehicle only	2	0	-6 $\pm$ 3

3) Compound 3: 1,1-Dioxo-3,3-dibutyl-5-phenyl-7-methylthio-8-(N-{(R)- $\alpha$ -[N-((S)-1-carboxy-2-methylpropyl)carbamoyl]-4-hydroxybenzyl }carbamoylmethoxy)-2,3,4,5-tetrahydro-1,2,5-benzothiadiazepine

Substance dosed	No of animals	Dose $\mu\text{mol/kg}$	Result
Compound 3	2	1.5	39 $\pm$ 2*
vehicle only	2	0	12 $\pm$ 2

\* Significance  $\leq 0.05$

5

The data generated in the Buenos constipated dog model show that all the tested IBAT inhibitors can reverse constipation in this model. The amount of faeces in each dog increased after treatment with compound 1, compound 2 and compound 3 by 38 $\pm$ 7, 23 $\pm$ 11 and 39 $\pm$ 2 g/day, respectively.

10

According to one aspect of the invention there is provided a pharmaceutical composition which comprises an IBAT inhibitor, or a pharmaceutically acceptable salt, solvate, solvate of such a salt or a prodrug thereof, in association with a pharmaceutically acceptable diluent or carrier for use in the treatment and / or prophylaxis of constipation.

15

The pharmaceutical compositions may be in a form suitable for oral administration, for example as a tablet or capsule, for parenteral injection (including intravenous, subcutaneous, intramuscular, intravascular or infusion) as a sterile solution, suspension or emulsion, for topical administration as an ointment or cream or for rectal administration as a suppository. In general the above compositions may be prepared in a conventional manner using conventional excipients.

20

According to another feature of the invention there is provided the use of an IBAT inhibitor, or a pharmaceutically acceptable salt, solvate, solvate of such a salt or a prodrug thereof, in the manufacture of a medicament for use in the treatment and / or prophylaxis of constipation, in a warm-blooded animal, such as man.

25

Therefore according to the present invention, there is provided a method of treatment and / or prophylaxis of constipation, in a warm-blooded animal, such as man, in need of such treatment and / or prophylaxis which comprises administering to said animal an effective amount of an IBAT inhibitor, or a pharmaceutically acceptable salt, solvate, solvate of such a salt or a prodrug thereof.

- 29 -

According to another feature of the invention there is provided the use of an IBAT inhibitor, or a pharmaceutically acceptable salt, solvate, solvate of such a salt or a prodrug thereof, in the treatment and / or prophylaxis of constipation, in a warm-blooded animal, such as man.

5           The IBAT inhibitor, or a pharmaceutically acceptable salt, solvate, solvate of such a salt or a prodrug thereof, will normally be administered to a warm-blooded animal at a unit dose within the range 0.5-5000 mg per square meter body area of the animal, i.e. approximately 0.001-50 mg/kg, and this would be expected to provide a therapeutically-effective dose. A unit dose from such as a tablet or capsule will usually  
10 contain, for example 0.05-250 mg of active ingredient. In one aspect of the invention a daily dose in the range of 0.01-50 mg/kg is employed. However the daily dose will necessarily be varied depending upon the host treated, the particular route of administration, and the severity of the illness being treated. Accordingly the optimum dosage may be determined by the practitioner who is treating any particular patient.

15

**Claims**

What we claim is:

- 5 1. The use of an IBAT inhibitor, or a pharmaceutically acceptable salt, solvate, solvate of such a salt or a prodrug thereof, in the treatment and / or prophylaxis of constipation, in a warm-blooded animal, such as man.
- 10 2. A pharmaceutical composition which comprises an IBAT inhibitor, or a pharmaceutically acceptable salt, solvate, solvate of such a salt or a prodrug thereof, in association with a pharmaceutically acceptable diluent or carrier for use in the treatment and / or prophylaxis of constipation.
- 15 3. The use of an IBAT inhibitor, or a pharmaceutically acceptable salt, solvate, solvate of such a salt or a prodrug thereof, in the manufacture of a medicament for use in the treatment and / or prophylaxis of constipation, in a warm-blooded animal, such as man.
- 20 4. A method of treatment and / or prophylaxis of constipation, in a warm-blooded animal, such as man, in need of such treatment and / or prophylaxis which comprises administering to said animal an effective amount of an IBAT inhibitor, or a pharmaceutically acceptable salt, solvate, solvate of such a salt or a prodrug thereof.
- 25 5. The use or method according to claims 1-4 wherein the constipation is functional constipation.
6. The use or method according to claims 1-4 wherein the constipation is constipation predominant irritable bowel syndrome.
- 30 7. The use or method of treatment according to any one of claims 1-6 wherein the IBAT inhibitor is selected from:

- 31 -

- 1,1-dioxo-3,3-dibutyl-5-phenyl-7-methylthio-8-(*N*-{(R)- $\alpha$ -[*N*-((R)-1-carboxy-2-methylthioethyl)carbamoyl]-4-hydroxybenzyl}carbamoylmethoxy)-2,3,4,5-tetrahydro-1,2,5-benzothiadiazepine;
- 1,1-dioxo-3,3-dibutyl-5-phenyl-7-methylthio-8-(*N*-{(R)- $\alpha$ -[*N*-((S)-1-carboxy-2-(R)-hydroxypropyl)carbamoyl]-4-hydroxybenzyl}carbamoylmethoxy)-2,3,4,5-tetrahydro-1,2,5-benzothiadiazepine;
- 1,1-dioxo-3,3-dibutyl-5-phenyl-7-methylthio-8-(*N*-{(R)- $\alpha$ -[*N*-((S)-1-carboxy-2-methylpropyl)carbamoyl]-4-hydroxybenzyl}carbamoylmethoxy)-2,3,4,5-tetrahydro-1,2,5-benzothiadiazepine;
- 10 1,1-dioxo-3,3-dibutyl-5-phenyl-7-methylthio-8-(*N*-{(R)- $\alpha$ -[*N*-((S)-1-carboxybutyl)carbamoyl]-4-hydroxybenzyl}carbamoylmethoxy)-2,3,4,5-tetrahydro-1,2,5-benzothiadiazepine;
- 1,1-dioxo-3,3-dibutyl-5-phenyl-7-methylthio-8-(*N*-{(R)- $\alpha$ -[*N*-((S)-1-carboxypropyl)carbamoyl]benzyl}carbamoylmethoxy)-2,3,4,5-tetrahydro-1,2,5-benzothiadiazepine;
- 15 1,1-dioxo-3,3-dibutyl-5-phenyl-7-methylthio-8-(*N*-{(R)- $\alpha$ -[*N*-((S)-1-carboxyethyl)carbamoyl]benzyl}carbamoylmethoxy)-2,3,4,5-tetrahydro-1,2,5-benzothiadiazepine;
- 1,1-dioxo-3,3-dibutyl-5-phenyl-7-methylthio-8-(*N*-{(R)- $\alpha$ -[*N*-((S)-1-carboxy-2-(R)-hydroxypropyl)carbamoyl]benzyl}carbamoylmethoxy)-2,3,4,5-tetrahydro-1,2,5-benzothiadiazepine;
- 20 1,1-dioxo-3,3-dibutyl-5-phenyl-7-methylthio-8-(*N*-{(R)- $\alpha$ -[*N*-(2-sulphoethyl)carbamoyl]-4-hydroxybenzyl}carbamoylmethoxy)-2,3,4,5-tetrahydro-1,2,5-benzothiadiazepine;
- 1,1-dioxo-3,3-dibutyl-5-phenyl-7-methylthio-8-(*N*-{(R)- $\alpha$ -[*N*-((S)-1-carboxyethyl)carbamoyl]-4-hydroxybenzyl}carbamoylmethoxy)-2,3,4,5-tetrahydro-1,2,5-benzothiadiazepine;
- 25 1,1-dioxo-3,3-dibutyl-5-phenyl-7-methylthio-8-(*N*-{(R)- $\alpha$ -[*N*-((R)-1-carboxy-2-methylthioethyl)carbamoyl]benzyl}carbamoylmethoxy)-2,3,4,5-tetrahydro-1,2,5-benzothiadiazepine;
- 1,1-dioxo-3,3-dibutyl-5-phenyl-7-methylthio-8-(*N*-{(R)- $\alpha$ -[*N*-{(S)-1-[*N*-((S)-2-hydroxy-1-carboxyethyl)carbamoyl]propyl}carbamoyl]benzyl}carbamoylmethoxy)-2,3,4,5-tetrahydro-
- 30 1,2,5-benzothiadiazepine; and

- 32 -

1,1-dioxo-3,3-dibutyl-5-phenyl-7-methylthio-8-(*N*-{(R)- $\alpha$ -[*N*-((S)-1-carboxy-2-methylpropyl)carbamoyl]benzyl}carbamoylmethoxy)-2,3,4,5-tetrahydro-1,2,5-benzothiadiazepine;

1,1-dioxo-3,3-dibutyl-5-phenyl-7-methylthio-8-(*N*-{(R)- $\alpha$ -[*N*-((S)-1-carboxypropyl)carbamoyl]-4-hydroxybenzyl}carbamoylmethoxy)-2,3,4,5-tetrahydro-1,2,5-benzothiadiazepine; and

1,1-dioxo-3,3-dibutyl-5-phenyl-7-methylthio-8-[*N*-((R)- $\alpha$ -carboxy-4-hydroxybenzyl)carbamoylmethoxy]-2,3,4,5-tetrahydro-1,2,5-benzothiadiazepine;

or a pharmaceutically acceptable salt, solvate, solvate of such a salt or a prodrug thereof.