

June 25, 1940.

W. E. SHERBONDY

2,205,604

DISPENSING APPARATUS FOR PLASTIC MATERIAL

Filed Feb. 28, 1936

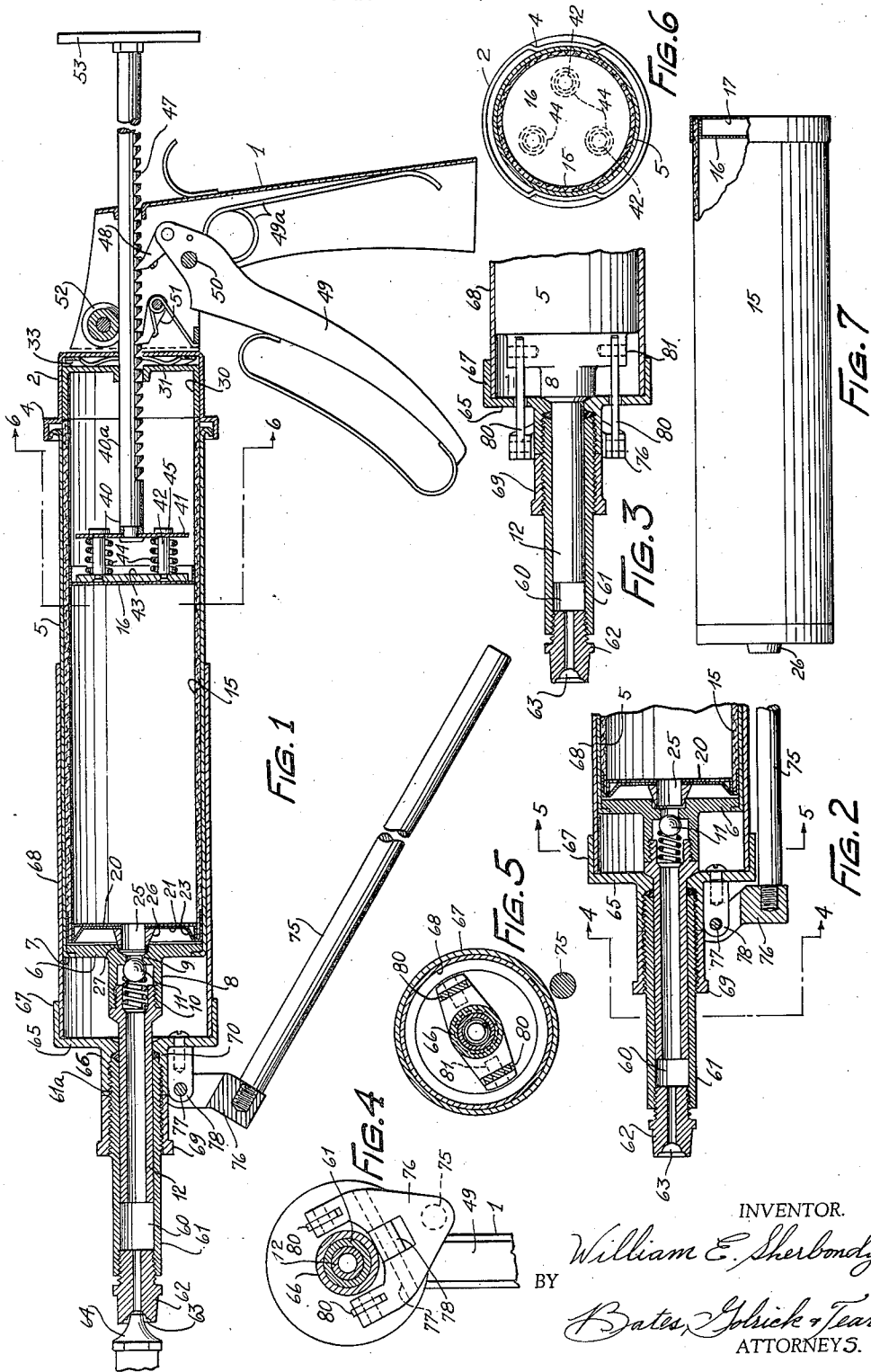

INVENTOR.

William E. Sherbondy

BY

Bates, Glick & Teare
ATTORNEYS.

UNITED STATES PATENT OFFICE

2,205,604

DISPENSING APPARATUS FOR PLASTIC MATERIAL

William E. Sherbondy, Shaker Heights, Ohio

Application February 28, 1936, Serial No. 66,201

4 Claims. (Cl. 221-47.4)

This invention relates to a system and apparatus for dispensing plastic substances, such as caulking materials, heavy greases and the like.

5 An object of the invention is to provide a dispensing gun of the type having means to eject plastic material at relatively low and high pressures, and wherein unusually high pressures can be obtained by an operator of average strength.

10 A further object is to provide a manually operable gun of the type having a relatively low pressure feeding means and a booster pressure cylinder and piston mechanism, the operation of which latter mechanism may be accomplished to obtain effective delivery pressures far in excess of those normally needed while concurrently operating the relatively low pressure feeding means.

15 A specific object is to provide a grease gun of the type adapted to be held in the hands of an operator, and pressed against a grease nipple on the mechanism or part to be lubricated to maintain a grease-tight connection therewith, by which gun an operator can, with one hand, maintain a constant flow of grease to the nipple at relatively low pressure, meanwhile, with the same hand, maintaining the grease tight connection, and, when and as necessary, can effectively operate the gun with his other hand to greatly increase the delivery pressure.

20 Another object is to provide a novel dispensing apparatus for plastic material, which may be quickly charged with such material without likelihood of spilling or smearing of the same on the apparatus, and which may be effectively operated to dispense the plastic material in the desired manner.

25 A specific object is to provide an improved booster for a dispensing gun i. e. a means to increase over normal the pressures at which the material may be dispensed.

30 A further object is to provide an improved dispensing gun for plastic material, whereby the plastic material can be effectively loaded in the gun in an inexpensive cartridge, such as a paper tube, and dispensed therefrom at exceedingly high pressures when necessary, without danger of damaging the cartridge or causing it to leak.

35 Other objects and features of the invention will become apparent from the following description relating to the accompanying drawing, showing the preferred form. The essential characteristics are summarized in the claims.

40 In the drawing, Fig. 1 is a sectional side elevation, showing the gun and a preferred form of cartridge for containing the plastic material to be dispensed; Fig. 2 is a fragmentary transverse sectional view of the booster mechanism of the gun; Fig. 3 is a sectional plan view, further showing the details of construction of the booster mechanism; Figs. 4 and 5 are transverse sectional views of the booster mechanism, as indicated by the lines 4-4 and 5-5 respectively on Fig. 2; Fig. 6 is a transverse sectional view, as indicated by the line 6-6 on Fig. 1, showing a detachable connection between the breech and barrel parts of the gun; and Fig. 7 is a side elevation of the preferred form of cartridge for containing the plastic material to be dispensed, the cartridge being broken away at one end to illustrate the preferred construction.

Referring to Fig. 1, the character 1 indicates a suitable transverse handle, to which is attached a hollow breech 2. The breech detachably supports a metal barrel 5, as by a bayonet lock connection therewith at 4; the inner end of the barrel (adjacent the breech) being open and unrestricted when detached from the breech. The outer end of the barrel is substantially closed, as by an end wall or head 6, rigidly attached as at 7 to the inturned outer end wall of the barrel 5. The head 6 has a reduced diameter extension 8, having a central discharge orifice 9, in which a spring-pressed ball check 11 or other suitable check valve device operates normally to permit discharge of plastic material from the barrel, while blocking return movement thereof into the barrel. The extension 8 supports, as at the threaded connection 10, an elongated cylindrical tube 12, the specific function of which (as a booster piston) will hereinafter be more fully described.

In the illustrated form, the "low-pressure cylinder" proper comprises a cartridge 15 for containing the plastic material for handling and/or shipment. It is to be understood, however, that the cartridge may in some instances be dispensed with, in which event a more conventional type of piston will be substituted for that shown, and will directly engage the barrel 5 of the gun, which, in the form shown, serves principally to contain and support the cartridge. This cartridge may be made substantially in accordance with the disclosure of my Patent, No. 2,106,577, Jan. 25, 1938.

The cylindrical body of the cartridge 15, (see Figs. 1 and 7) comprises preferably an ordinary paper tube, made as mailing tubes generally are, and suitably treated to effectively contain greasy substances. The cartridge substantially fits the inside of the metal barrel 5, and is slid into it through its open inner end, when the barrel is detached from the breech. The cartridge has a movable end closure member 16, which, as shown in Fig. 1, has been moved partly through the tube 15 from its initial position, adjacent the breech, by a spring pusher device 40 on an operating stem 40a, which device will later be described in detail.

For shipping purposes, the cartridge has a removable outside closure member in the form of a cap 17 (shown in Fig. 7 only). Both closure

60

members have flanges which extend in opposite directions, so that the wall of the tube is embraced between the two flanges. The cap 17 is slipped off prior to placing the cartridge in the gun.

The closure device at the outer end of the tube 15 comprises, as shown, a flanged inner disc 20, the flange of which extends forwardly from the general plane of the disc and into continuous contact with the inner marginal surface of the tube. An outer disc 21 lies in face-to-face relationship with the inner disc and has a forwardly extending hollow flange effect 23, which generally embraces both the flange of the disc 20 and the adjacent margin of the tube. The material of which the tube is composed is tightly compressed between the inner and outer flange effects on the discs to prevent leakage.

Both discs 20 and 21 are centrally apertured as at 25 to provide a discharge passage, and one of the discs (the outer one, as shown) carries a short frustoconical spout device 26, having a discharge aperture in alignment with the discharge apertures 25 of the discs.

For retaining the plastic material during shipment, the discharge apertures of the closure device, just described, are closed, preferably by means of a frangible paper patch, (not shown) which may be pasted over the opening on the inner surface of the disc 20. Alternatively, the outer end of the spout device 26 may be closed by a suitable plug (not shown). The frangible disc may be broken, or the plug, if used, removed, just prior to placing the cartridge in the gun.

When the cartridge is placed in the gun, the conical surface of the spout device 26 seats against an edge 27 of the discharge orifice 9 in the head 6 of the barrel. Alternatively a separate compressible non-metallic annular insert (not shown) may occupy said orifice as a seat for the spout. Cooperating means on the breech, to be presently described, shoves the cartridge forwardly in the barrel to hold the spout 26 tight in such seat. The open rear end of the cartridge projects slightly beyond the adjacent end of the barrel 5 to assist in removing the cartridge after it is emptied.

When the detachable connection at 4 is made between the barrel 5 and the breech 2, the inner or rear end of the tube 15 is brought into continuously abutting relationship with a sleeve 30, which slidably fits the breech. This sleeve 30 may comprise the rim or flange of a cup device 31, the cup being pressed outwardly toward the tube 15, (thereby maintaining a tight joint at 27 at the outer end of the tube), by a suitable spring 33 contained between the rear wall of the breech 2 and the base portion of the cup 31. The spring 33 may comprise a generally circular piece of flat spring stock, bent into sinuous form.

The pusher device 40 for the movable closure member 16 of the tube 15, as stated above, is mounted on the outer end of a circular stem 40a, and the pusher preferably includes yielding means whereby the operation of the plunger stem is somewhat independent of the movement of the closure device 16, which is moved thereby. As shown, there is an inner pusher plate 41, swivelled on the outer end of the stem 40a, and which slidably receives a plurality of pins 42 anchored in an outer pusher plate 43. Surrounding the pins 42 and bearing against both plates 41 and 43, are suitable compression springs 44. The pins have heads at 45 which limit the expansion of the springs and which engage the

plate 41 when the pusher device is in fully expanded condition (as shown).

It will be noted that the handle device 1 is positioned transversely of the barrel so that it is in a very effective position for manually shoving the barrel in an endwise direction, as in order to maintain coupling pressure on a grease nipple. The handle supports a step-by-step mechanism, which, while maintaining such endwise shoving pressure, is operative by the same hand to rapidly eject the material from the gun under relatively low pressure, which is all that is required in most instances. The arrangement also permits rapid withdrawal of the stem toward the breech, after the main cylinder of the gun has been emptied.

As shown, the step-by-step ejecting mechanism comprises ratchet teeth 47, disposed along one side of the stem, as shown in Fig. 1, and the teeth are adapted to be intermittently engaged by an operating pawl 48, which is pivoted to a trigger-like operating lever 49, the latter being, in turn, pivoted as at 50 to the stock or handle 1. The operating pawl has a suitable spring, not shown, normally urging it toward the ratchet teeth on the stem 40a and the lever 49 has a suitable return spring at 49a. A spring-pressed detent pawl 51 holds the stem in advanced position during return movement of the operating pawl 48 to engage a new tooth. A suitable reaction roller 52 is mounted on the stock 1, and engages the surface of the stem 40a opposite the zone of operation of the pawls 48 and 51.

The stem 40a is returnable to initial position (in which the spring pusher device 40 occupies or lies adjacent the cup device 31) by giving the stem a half-turn, as by an operating handle 53; such half-turn disengaging the teeth 47 from both pawls.

Referring now to the outer end of the gun, it will be seen that the plastic material, discharged from the cartridge or the barrel 5, into the tube 12, enters an enlarged cylindrical space 60, within a sleeve 61, which is slidably guided on the tube 12, and thence through a fitting 62 in the sleeve 61, the fitting being adapted as by a cupped end recess 63 for application to a grease nipple of the form shown at 64, Fig. 1. This form of nipple is that well known as the push coupling type. Any other types of fittings and couplings may be used instead. For caulking, various shaped spouts may be interchangeably fitted to the sleeve 61, or the sleeve may be appropriately shaped to serve without any special fittings.

In the normal operation of the gun, with the illustrated fitting 62, the operator holds the fitting against the grease nipple with one hand on the handle 1, and operates the trigger lever 49 with the fingers of the same hand to force grease from the cartridge e. g. through the various channels described, including that of the fitting 62. In so doing, operating pressure on the body of material in the cartridge is maintained during the entire operation by the yielding pusher plate device 40, above described, notwithstanding the fact that the stem 40a retracts, or tends to retract a short distance between steps, (for engagement with the detent), as during the forward swinging of the trigger lever 49, necessary to enable the pawl 48 to engage a new tooth 47.

The yielding pressure plate device has the further function of always maintaining the detent pawl 51 in operative engagement with one of the teeth 47, for, if the forward movement of the operating pawl 48 leaves the detent pawl out

of engagement with the abutment surface of a tooth 47, the spring 44 will ordinarily have been compressed a sufficient amount to shove the stem rearwardly until the detent pawl abuts the proximate ratchet tooth.

Referring now to the booster mechanism, this, as shown, includes the tubular extension 12 of the barrel 5 as the effective booster piston, and the sleeve 61 as the effective cylinder for the booster.

The sleeve 61, as shown, is threaded at 61a into a rearwardly cupped head 65, having a central tubular extension 66 and an outer flange 67, the latter carrying a sleeve 68, which slides on the outer surface of the barrel 5 as a guarding housing for the relatively movable parts, and as a supplemental guide for the sleeve 61.

Preferably, a packing gland is provided at 70 between the sleeve 61 and discharge tube 12, in order to prevent leakage of material from the space 60 past the contacting walls of the tube and sleeve into the space between the two heads 6 and 65. The sleeve 61, as shown, forms an active part of the packing gland, and may carry a lock or jam nut as at 69 bearing against the central extension of the head 65.

The means whereby the booster may be manually operated concurrently with the main (low pressure) gun mechanism, above described, i. e. without removing hand pressure from the handle 1 and without having to release the trigger lever 49, preferably includes a hand lever 75 having a yoked head 76 pivoted as at 77 to a bracket 78 extending outwardly from the head 65 of the booster cylinder. The arms of the yoked head are secured to a pair of links 80, which lie on opposite sides of the sleeve 61, as shown in Fig. 3, extend freely through openings in the head 65, and are connected as at 81 with the barrel 5.

A suitable angular relationship of the lever 75 with respect to the stock or handle 1 and trigger-lever 49 thereof is indicated in Fig. 4, wherein it will be seen that the hand lever 75 moves in a plane sufficiently offset from the plane of the handle 1 so as to clear it and the operator's hand thereon, notwithstanding the length of the lever 75. For convenience in illustration, the angular relationship of operating levers, just described, is not shown in Fig. 1.

In operation, the lever 75 may be swung out substantially as shown in Fig. 1, during the operation of the relatively low-pressure piston and cylinder parts in speedily ejecting lubricant or other plastic material from the gun. When abnormally high pressure is called for, (as by reason of stoppage of the receiving channels—beyond or in the nipple 64 e. g.) the operator maintains manual pressure on the stock or handle 1 to preserve the sealed connection as at 63, with the nipple 64, and swings the lever 75 inwardly toward the axis of the barrel 5. Thereupon, due to the relatively small diameter of the booster piston and cylinder, greatly increased discharge pressure is made available. Operation of the booster is accomplished without necessitating the removal of the hand of the operator from the stock 1, or his fingers from operating position on the trigger lever 49, and without necessitating removal of force incident to maintaining a tight connection between the fitting 62 and the grease nipple. Thus, the boosting operation may be performed repeatedly; for as the lever 75 is swung out, the operator may work the trigger lever 49 to feed new lubricant to the

space 60 and the bore of the tube 12, in other words, re-loading the booster. During operation of the booster lever 75 the ball-check 11 prevents return movement of the plastic material from the booster cylinder and piston passages into the barrel 5 or cartridge 15.

I claim:

1. In a dispensing gun, a main cylinder arranged lengthwise of the gun and having a discharge passage at one end of the gun adapted to be forced into peripherally sealed relationship with a receiving passage by lengthwise pressure applied to the gun, piston means in the cylinder, feeding means for the piston, said means including a fixed handle on the main cylinder and an actuating member operable by the fingers of one hand while maintaining pressure lengthwise of the gun on said handle, a booster cylinder and piston operably associated with the discharge passage of the main cylinder to increase the feeding force of material at the discharge passage and lever means operatively connecting the boosted cylinder and pistons, said lever means being operable by the other hand of said operator without having to release said endwise pressure on the gun at said handle.

2. In a grease gun, a cylinder adapted to contain the grease, piston means therein for ejecting the grease from the cylinder, step-by-step feeding means at one end of the cylinder, including a transverse handle and trigger-lever device adjacent thereto for operating the step-by-step means while maintaining pressure on the barrel toward the end opposite the handle, a discharge duct for the cylinder terminating in a fitting adapted to be pressed against a grease nipple to maintain a grease-tight connection therewith and retractable relative to the cylinder, a booster in the discharge duct operable by retracting said discharge duct toward said cylinder, and means for manually operating the booster.

3. A dispensing gun for plastic material, a cylinder for containing the material, a discharge tube leading from said cylinder, a check valve for preventing return of the material from the discharge tube into the cylinder, an extension discharge tube telescopically engaging the discharge tube first mentioned and projecting beyond it and having a fitting to engage the nipple to be filled, a sleeve connected to the extension tube and telescopically embracing the cylinder, means for feeding the plastic material into a cylinder and through the discharge tube carried thereby and means for decreasing the distance between the cylinder and fitting for the nipple to boost the pressure on the material being discharged.

4. In a dispensing gun for plastic material, a cylinder for containing the material, a low pressure piston in the cylinder, step-by-step mechanism carried by the cylinder for operating the piston, a discharge tube extending from the cylinder, a check valve between the cylinder and discharge tube, a sleeve telescopically embracing one end of the cylinder, an extension discharge tube carried by said sleeve and telescopically embracing the discharge tube first mentioned and carrying a fitting to engage the nipple to be filled, and a booster operating lever pivotally mounted on the sleeve and connected to the cylinder to decrease the overall length of the discharge tubes.

WILLIAM E. SHERBONDY.