

(19) World Intellectual Property Organization  
International Bureau



(43) International Publication Date  
4 July 2002 (04.07.2002)

PCT

(10) International Publication Number  
WO 02/051622 A3

- (51) International Patent Classification<sup>7</sup>: **B29C 55/24**, 67/00 // A61F 2/04, B29K 27:18, B29L 23:00
- (74) Agents: **SALVATORE, J., Abbruzzese et al.**; Hoffmann & Baron, LLP, 6900 Jericho Turnpike, Syosset, NY 11791 (US).
- (21) International Application Number: PCT/US01/48107
- (81) Designated States (*national*): AE, AG, AL, AM, AT, AU, AZ, BA, BB, BG, BR, BY, BZ, CA, CH, CN, CO, CR, CU, CZ, DE, DK, DM, DZ, EC, EE, ES, FI, GB, GD, GE, GH, GM, HR, HU, ID, IL, IN, IS, JP, KE, KG, KP, KR, KZ, LC, LK, LR, LS, LT, LU, LV, MA, MD, MG, MK, MN, MW, MX, MZ, NO, NZ, PL, PT, RO, RU, SD, SE, SG, SI, SK, SL, TJ, TM, TR, TT, TZ, UA, UG, UZ, VN, YU, ZA, ZW.
- (22) International Filing Date: 11 December 2001 (11.12.2001)
- (25) Filing Language: English
- (26) Publication Language: English
- (30) Priority Data: 09/748,417 26 December 2000 (26.12.2000) US
- (84) Designated States (*regional*): ARIPO patent (GH, GM, KE, LS, MW, MZ, SD, SL, SZ, TZ, UG, ZM, ZW), Eurasian patent (AM, AZ, BY, KG, KZ, MD, RU, TJ, TM), European patent (AT, BE, CH, CY, DE, DK, ES, FI, FR, GB, GR, IE, IT, LU, MC, NL, PT, SE, TR), OAPI patent (BF, BJ, CF, CG, CI, CM, GA, GN, GQ, GW, ML, MR, NE, SN, TD, TG).
- (71) Applicant: **SCIMED LIFE SYSTEMS, INC.** [US/US]; One SciMed Place, Maple Grove, MN 55331-1566 (US).
- (72) Inventors: **HILL, Jason, P.**; 7333 Drew Avenue No., Brooklyn Park, MN 55443 (US). **LININGER, James, R.**; 4472 Independence Avenue North, New Hope, MN 55428 (US). **BROWN, Brian, J.**; 178 Jandel Avenue Northeast, Hanover, MN 55341 (US).
- Published: — with international search report

[Continued on next page]

(54) Title: METHOD OF REDUCING THE WALL THICKNESS OF A PTFE TUBE AND PRODUCT FORMED THEREBY

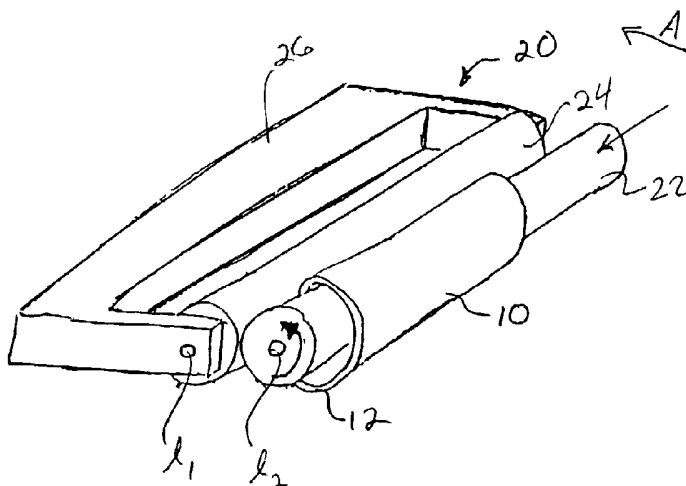

(57) Abstract: A thin wall PTFE tube is formed from an extruded green tube (10). The PTFE tube includes an inner tubular surface and an opposed outer tubular surface defining a tubular wall of a first thickness. The tubular wall is compressed to uniformly reduce the wall-thickness and circumferentially orient the tube. The PTFE tube is positioned over a first elongate roller (22) with the inner tubular surface being in contact therewith. A second roller (24) is positioned against the outer tubular surface of the PTFE tube. The pair of rollers are counter rotated so as to circumferentially compress the tubular (12) wall between the rollers (22, 24). This results in the uniform reduction in the tubular wall (12) from the first thickness to a lesser second thickness and a circumferential orientation otherwise not occurring in an extruded PTFE paste extrusion.



WO 02/051622 A3



---

**(88) Date of publication of the international search report:**  
3 April 2003

*For two-letter codes and other abbreviations, refer to the "Guidance Notes on Codes and Abbreviations" appearing at the beginning of each regular issue of the PCT Gazette.*

# INTERNATIONAL SEARCH REPORT

In: Application No  
PCT/US 01/48107

<b>A. CLASSIFICATION OF SUBJECT MATTER</b> IPC 7 B29C55/24 B29C67/00 //A61F2/04, B29K27:18, B29L23:00		
According to International Patent Classification (IPC) or to both national classification and IPC		
<b>B. FIELDS SEARCHED</b>		
Minimum documentation searched (classification system followed by classification symbols) IPC 7 B29C B29D		
Documentation searched other than minimum documentation to the extent that such documents are included in the fields searched		
Electronic data base consulted during the international search (name of data base and, where practical, search terms used) EPO-Internal, WPI Data, PAJ		
<b>C. DOCUMENTS CONSIDERED TO BE RELEVANT</b>		
Category *	Citation of document, with indication, where appropriate, of the relevant passages	Relevant to claim No.
X Y	DE 43 36 175 C (LENZENBACH JUERGEN) 6 October 1994 (1994-10-06) the whole document  --- US 3 225 129 A (TAYLOR JOHN S ET AL) 21 December 1965 (1965-12-21) column 3, line 5 - line 9; claim 1; figure 2  --- US 5 843 173 A (KUO CHRIS ET AL) 1 December 1998 (1998-12-01) column 3, line 63 -column 4, line 27  --- DE 25 36 358 A (CANON KK) 26 February 1976 (1976-02-26) figures 9,10  --- -/--	1-5,12, 28,29,33 7,8, 22-27, 31,32  1-5,11, 28-30,33  22-27  7,8,31, 32
<input checked="" type="checkbox"/> Further documents are listed in the continuation of box C. <span style="margin-left: 200px;"><input checked="" type="checkbox"/> Patent family members are listed in annex.</span>		
* Special categories of cited documents :		
*A* document defining the general state of the art which is not considered to be of particular relevance *E* earlier document but published on or after the international filing date *L* document which may throw doubts on priority claim(s) or which is cited to establish the publication date of another citation or other special reason (as specified) *O* document referring to an oral disclosure, use, exhibition or other means *P* document published prior to the international filing date but later than the priority date claimed		*T* later document published after the international filing date or priority date and not in conflict with the application but cited to understand the principle or theory underlying the invention *X* document of particular relevance; the claimed invention cannot be considered novel or cannot be considered to involve an inventive step when the document is taken alone *Y* document of particular relevance; the claimed invention cannot be considered to involve an inventive step when the document is combined with one or more other such documents, such combination being obvious to a person skilled in the art. *&* document member of the same patent family
Date of the actual completion of the international search  <p style="text-align: center;">7 August 2002</p>	Date of mailing of the international search report  <p style="text-align: center;">16/08/2002</p>	
Name and mailing address of the ISA European Patent Office, P.B. 5818 Patentlaan 2 NL - 2280 HV Rijswijk Tel. (+31-70) 340-2040, Tx. 31 651 epo nl, Fax: (+31-70) 340-3016	Authorized officer  <p style="text-align: center;">Cordenier, J</p>	

## INTERNATIONAL SEARCH REPORT

In International Application No  
PCT/US 01/48107

C.(Continuation) DOCUMENTS CONSIDERED TO BE RELEVANT		
Category °	Citation of document, with indication, where appropriate, of the relevant passages	Relevant to claim No.
A	GB 1 148 243 A (FLUORODYNAMICS INC) 10 April 1969 (1969-04-10) figures 6,7 ----	1, 18
A	US 4 613 474 A (DONATI GINO) 23 September 1986 (1986-09-23) figures ----	19-21
A	US 4 060 577 A (COLLINS RICHARD D) 29 November 1977 (1977-11-29) column 2, line 64 - line 68 ----	11, 30
A	US 2 994 933 A (WOLFE SHEEMON A) 8 August 1961 (1961-08-08) figure 1 ----	1-6
A	US 5 207 960 A (MORET DE ROCHEPRISE BERNARD) 4 May 1993 (1993-05-04) abstract ----	1
A	US 4 225 547 A (OKITA KOICHI) 30 September 1980 (1980-09-30) column 4, line 1 - line 8 -----	24

## INTERNATIONAL SEARCH REPORT

 International Application No  
 PCT/US 01/48107

Patent document cited in search report		Publication date	Patent family member(s)	Publication date
DE 4336175	C	06-10-1994	DE 4336175 C1	06-10-1994
US 3225129	A	21-12-1965	NONE	
US 5843173	A	01-12-1998	US 5641373 A	24-06-1997
			US 6267834 B1	31-07-2001
			AT 205776 T	15-10-2001
			AU 692707 B2	11-06-1998
			AU 5545796 A	07-11-1996
			BR 9608191 A	21-07-1998
			CA 2216383 A1	24-10-1996
			DE 69615356 D1	25-10-2001
			DE 69615356 T2	13-06-2002
			DK 821648 T3	21-01-2002
			EP 0821648 A1	04-02-1998
			ES 2166885 T3	01-05-2002
			JP 11503981 T	06-04-1999
			PT 821648 T	28-02-2002
			WO 9633066 A1	24-10-1996
			US 2001050132 A1	13-12-2001
DE 2536358	A	26-02-1976	JP 1163653 C	26-08-1983
			JP 51140970 A	04-12-1976
			JP 57055591 B	25-11-1982
			JP 1205269 C	11-05-1984
			JP 51020971 A	19-02-1976
			JP 53032388 B	07-09-1978
			JP 51020972 A	19-02-1976
			JP 55014725 B	18-04-1980
			JP 51020973 A	19-02-1976
			JP 1045678 C	28-05-1981
			JP 51020974 A	19-02-1976
			JP 55035244 B	12-09-1980
			DE 2536358 A1	26-02-1976
GB 1148243	A	10-04-1969	NONE	
US 4613474	A	23-09-1986	IT 1199351 B	30-12-1988
			AT 34696 T	15-06-1988
			CA 1241167 A1	30-08-1988
			DE 3563000 D1	07-07-1988
			EP 0150159 A2	31-07-1985
			JP 60178021 A	12-09-1985
US 4060577	A	29-11-1977	NONE	
US 2994933	A	08-08-1961	NONE	
US 5207960	A	04-05-1993	FR 2662632 A1	06-12-1991
			AT 116193 T	15-01-1995
			DE 69106223 D1	09-02-1995
			DE 69106223 T2	10-08-1995
			DE 459907 T1	21-05-1992
			DK 459907 T3	29-05-1995
			EP 0459907 A1	04-12-1991
			ES 2069237 T3	01-05-1995
			GR 3015472 T3	30-06-1995
			JP 2041858 C	09-04-1996

## INTERNATIONAL SEARCH REPORT

 Int'l Application No  
 PCT/US 01/48107

Patent document cited in search report	Publication date	Patent family member(s)	Publication date
US 5207960	A	JP 5092496 A	16-04-1993
		JP 7071825 B	02-08-1995
US 4225547	A	30-09-1980	
		JP 1372936 C	07-04-1987
		JP 53041362 A	14-04-1978
		JP 53045347 B	06-12-1978
		JP 1030100 C	22-01-1981
		JP 53058579 A	26-05-1978
		JP 55023537 B	24-06-1980
		JP 1254231 C	12-03-1985
		JP 52073253 A	18-06-1977
		JP 59018553 B	27-04-1984
		JP 1207896 C	29-05-1984
		JP 52072765 A	17-06-1977
		JP 58028107 B	14-06-1983
		CA 1081422 A1	15-07-1980
		CA 1094767 A2	03-02-1981
		DE 2656882 A1	23-06-1977
		FR 2335327 A1	15-07-1977
		GB 1573196 A	20-08-1980
		US 4104394 A	01-08-1978