

19



Europäisches Patentamt
European Patent Office
Office européen des brevets



11 Publication number:

0 357 441 B1

12

EUROPEAN PATENT SPECIFICATION

45 Date of publication of patent specification: **10.11.93** 51 Int. Cl.⁵: **H01Q 1/04**

21 Application number: **89308857.5**

22 Date of filing: **01.09.89**

54 **Improvements in or relating to underwater communication devices.**

30 Priority: **02.09.88 GB 8820719**

43 Date of publication of application:
07.03.90 Bulletin 90/10

45 Publication of the grant of the patent:
10.11.93 Bulletin 93/45

84 Designated Contracting States:
DE FR SE

56 References cited:
EP-A- 0 110 554 WO-A-86/04873
DE-A- 2 209 544 GB-A- 1 534 852
US-A- 3 460 058 US-A- 4 189 786

ELECTRICAL/ELECTRONIC POWER & CONTROL, PRODUCT ENGINEERING, vol. 40, no. 12, 16th June 1969, pages 94-95; "Coded sounds in the sea direct underwater work more reliably"

73 Proprietor: **LAWBOROUGH CONSULTANTS LIMITED**
18 Charing Cross Road
London WC2 OHR(GB)

72 Inventor: **Parker, Bernard Dollman**
The Garden Cottage, Hawkesell House
West Lavington, Wiltshire(GB)
Inventor: **Hickey, Christopher, Daniel, Downing,**
Jarretts Farm, Brantbridge Lane, Balcombe,
Haywards Heath, West Sussex,(GB)

74 Representative: **Bayliss, Geoffrey Cyril et al**
BOULT, WADE & TENNANT
27 Furnival Street
London EC4A 1PO (GB)

EP 0 357 441 B1

Note: Within nine months from the publication of the mention of the grant of the European patent, any person may give notice to the European Patent Office of opposition to the European patent granted. Notice of opposition shall be filed in a written reasoned statement. It shall not be deemed to have been filed until the opposition fee has been paid (Art. 99(1) European patent convention).

Description

This invention relates to underwater communication devices.

A major problem which is experienced by Hunter type weapons of the anti-submarine variety is the limited range of acoustic-sonar detectors and hence the short range at which a target can be identified. This drawback can be overcome if sensing devices are positioned well away from, and peripheral to, the weapons. Signals received by such sensing devices could be analysed, a vessel identified by comparison with a library of voice prints, and a coded message transmitted to a weapon, all well in advance of the approach of a possible target. Alternatively, the voice print could be broadcast in its entirety. In either event, the response time available to the weapon system could be significantly enhanced. Similarly, sensors and weapons could be positioned on the sea bed in such a manner as to form not only a "safe haven" for friendly vessels, but also as a trap for enemy shipping which tried to penetrate the safe area. It would be particularly useful for friendly vessels which believe they may be being shadowed/followed, to run through a series of underwater communication devices which could detect and disseminate information on the shadowing vessel and prepare weapon systems to destroy it. Such weapon systems could be of a type described or illustrated in EP-A-0110554.

Furthermore, a major problem for Naval Forces is to be able to maintain surveillance on hostile forces whilst remaining at a safe distance from such hostile forces and in particular when vulnerable to land based aircraft. It is even more difficult to maintain surveillance and at the same time remain undetected whilst so doing. This invention is concerned with apparatus directed towards that purpose.

Hitherto no suitable device has been available for long term service underwater for detecting vessel movements and then providing a long range signal to communicate the detection of an enemy vessel or vessels.

This invention provides an underwater communications device comprising an enclosure, means to anchor the enclosure to the sea bed, sonar listening equipment in the enclosure for receiving sonar signals from the surrounding water, a plurality of communications beacons enclosed in individual buoyant containers, means for releasably holding the beacon in the enclosure and means for releasing a beacon from the enclosure in response to receipt of a sonar signal by said sonar receiving means to allow the beacons to surface and to transmit a signal pursuant to the receipt of said sonar signal.

More specifically the sonar receiving apparatus may include means to store different sonar signals emitted by different surface or underwater vessels whether hostile or friendly, means to receive and compare a sonar signal with said stored sonar signals and means to initiate release of a beacon in response to any sonar signal identified as being that of a hostile vessel to transmit a signal indicating the presence of a hostile vessel.

In addition the sonar receiving apparatus may be arranged to supply information to the beacon including the identity of the vessel detected to be transmitted by said beacon after release from the enclosure and on reaching the surface.

In any of the above arrangements, the beacons may embody radio transmitters for transmitting radio signals on surfacing indicating the detection of a "hostile" vessel.

In any of the above arrangements the apparatus may be provided with means for communicating with one or more remote weapon systems for activating the weapon systems to be used against a target detected by the sonar equipment.

Also in any of the above arrangements the enclosure may have an upper part containing the sonar equipment and said beacons and a lower part having means to bury the lower part in the sea bed.

The following is a description of some specific embodiments of the invention, reference being made to accompanying drawings in which:

Figure 1 is a diagrammatic sectional view through an underwater communication device showing the device partly buried in the sea bed; and

Figure 2 is a plan view of the device of Figure 1; and

Figure 3 is a detailed view of a modified form of communication device.

Referring to the drawings, an underwater communication device is shown comprising a watertight elongate vertically extending container 10 which is intended to be partially or wholly buried in the sea bed 11. The upper part of the container 10 contains a first, inner canister 12 in which a plurality of individually releasable communication beacons 13 are housed and the lower part of the container houses a second canister 14 containing a burying mechanism for the container 10.

The outer container 10 is, as indicated above, of elongate form and generally cylindrical cross-section. The container is buried or partially buried within the sea bed 11 as illustrated in the drawing to minimise the risk of the device being detected or damaged. For this purpose, the container has self-burying means comprising, firstly a centrifugal pump 15 for removing sand or silt from under the bottom end of the container; secondly a spiral or

helical agitator/auger 16 for loosening the material on the sea bed and thirdly a high pressure pump 17 for pumping sea water to nozzles 18 disposed around the periphery of the lower end of the container 10 and for loosening sand or silt under the container. The centrifugal pump 15 is driven by an electric drive motor 19 through a gear train 20, the motor being powered by batteries 21. This pump sucks up sand and silt from the sea bed, as indicated by chain lines 22, and forces it radially outwardly to the lower end of an annular region 23 between the outer container 10 and the inner canisters 12 and 14. The sand and silt are forced upwardly through this annular region to be expelled as indicated by arrows 24 at the upper end of the container 10. In the embodiment illustrated, the agitator/auger 16 is driven from the drive shaft of the pump 15. This shaft also drives a high pressure pump 17.

The device is laid in position by dropping it into the sea and it is so constructed that when released in water, it falls with the burying mechanism downwards so this end settles on the sea bed. Operation of the drive motor 19 driving pump 15 and 17 and the agitator/auger 16 forces sand or silt or the like in the sea bed away from the underneath of the container thereby allowing the container to sink into the sea bed in a substantially upright position. Normally, the container would be substantially wholly buried to minimise the risk of detection by underwater search equipment or accidental damage by equipment moving along the sea bed. Sand or silt may get washed over the container by the sea with the result that the container may be completely covered.

Control of the self-burial means may be effected using appropriate sensors. A first sensor 25 to detect initial contact with the sea bed and initiate operation of the motor 19 is mounted at the lower end of the container 10 and a second sensor 26 is mounted adjacent the upper end of container 10 to detect burial of the container to the required depth.

The upper canister 12 is formed with a central vertically extending housing 30 the lower part of which contains a control assembly 31 including a sonar receiver, a data processing device and an interface device for interfacing the sonar receiver with the radio beacons 13. The upper part of the housing 30 is an aerial housing 32 containing an extendible sonar aerial mechanism 33 which extends automatically once the container is fully buried as detected by the sensor 26.

Around the central housing 30 of the canister 12 there are four vertically extending tubes 35 each of which has an open end 36 closed by a watertight seal 37. Within each of the tubes there is a "torpedo" shaped communications beacon 38 comprising, from its upper end, a nose 39, and

ground plane antenna with flexible ground plane 40, a buoyancy tank 41, an electronics bay 42, a battery pack 43 and a bottom end base 44. The base 44 of each beacon forms a piston in the lower end of its tube 35 and the lower end of the tube is connected by a passage 46 to a pneumatically or hydraulically operated ram 47 containing a vertically operating piston assembly 48. The cylinder 47 is connected by a lateral passage 49 through a non-return inlet valve 50 to the aforesaid annular passage 23 to receive a charge of water therefrom when the ram 48 is returned.

Ram 48 is advanced to displace water from the cylinder 47 through passage 46 into the lower end of tube 35 to force the beacon 38 contained in the tube upwardly fracturing the watertight seal 37 to project out of the tube. Once the seal 37 has been fractured, the tube 35 will flood and the beacon will float upwardly out of the tube to the surface under the influence of its own positive buoyancy. Operation of the hydraulic/pneumatic rams connected to piston assemblies 48 is effected by a rotary switch construction (not shown) triggered by a signal from the control assembly 31 described above.

It would be appreciated that other arrangements may be provided for displacing the beacons 38 from the tubes. For example the seals 37 could be frangible or held in position with vacuum differential on an "O" ring and solenoid controlled valves may be provided connecting the tubes to the annular chamber to flood the tube of a beacon to be deployed. Once the tube has been flooded to bring the tube into equilibrium, the beacons could be driven out with hydro-static pressure or a gas charge such as that provided by firing a pyrotechnic type cartridge could be utilised.

The control assembly 31 of the underwater communication device receives sonar signals from vessels passing within range of the device. It is well known that each vessel has its own individual noise pattern and the control assembly has a memory in which the noise patterns of all known friendly and enemy vessels are recorded. The control assembly has facilities for analysing received sonar signals to determine whether they are of friendly or enemy vessels and, if of enemy vessels, to initiate the firing of one of the radio beacons 38 to the surface to transmit a signal by radio warning that an enemy vessel has been detected. The radio beacons broadcast coded messages on surfacing and, following a set period of broadcasting and after acknowledgement that a message has been received, a programme to self-destruct the beacon is initiated automatically. The control assembly may also be arranged to cause the radio to transmit a signal identifying the vessel detected. These messages could be received by ships or aircraft hundreds of miles away and, if necessary, then re-

transmitted either by radio to other ships or aircraft or, acoustically or by sonar to alert and activate weapon systems already in position on the sea bed. Examples of such weapon systems are described and illustrated in EP-A-0110554.

Thus by deploying underwater communication devices in accordance with the invention at strategic locations such as within the vicinity of enemy ports or passages used by enemy vessels, a listening watch over vast areas can easily be maintained and the information gathered, passed to friendly forces at the earliest possible moment.

Reference is now made to Figure 3 of the drawings in which a modified arrangement is illustrated. In the modified arrangement, each of the tubes 35 tapers towards its lower end and the bodies of the beacons 38 taper in a corresponding manner and are dimensioned to provide a narrow gap 55 between the outer wall of the beacon 38 and the encircling wall of the tube 35. At the upper end of the inner canister 12 annular resilient "O" ring seals 56 are mounted around the upper open ends of the tubes 35 and each of the beacons 38 has an annular rim adjacent its upper end to engage the encircling seal 56 of the respective tube 35 in which the beacon is housed.

The lower end of each beacon 38 is formed with an annular skirt 58 having an inner annular rib 59. A plurality of latches 60 are mounted on pivots 61 around the lower end of the tube 35 to project into the skirt 58 of the beacon and are spring loaded by tension springs 62 to engage with the rib 59 and retain the beacon in the tube. The latches are retracted to release the beacon by solenoids indicated at 63.

A heavy compression spring 64 is disposed in the underside of the beacon 38 and the bottom wall 65 of the tube 35 to assist in spacing the beacon from the tube when the latches 60 have been released. The beacon could, equally, be discharged with the assistance of a gas charge or hydraulic pressure applied to the underside of the beacon.

The tubes 35 housing the beacons are initially filled with a nitrogen atmosphere to minimise corrosion of the beacons and their release mechanisms when the communication device is installed on the sea bed. There will be a considerable pressure differential depending on the depth of water in which the device is located tending to hold the beacons in the container tubes. In order to relieve this pressure differential, each container tube has a solenoid controlled valve (not shown) connecting the tube to the encircling annular region 23 between the inner and outer canisters to allow water to bleed into the tubes 35 when the solenoid controlled valve is open. Both the solenoid controlled valves and the solenoid controlled latches holding

the beacons in the tubes are triggered by said rotary switch from the control assembly when a beacon is to be released as described above. In a simplified arrangement, the "O" ring seals 56 are omitted as are the solenoid controlled valves for the tubes 35 and the tubes are allowed to flood with sea water on immersion of the device in the sea. The solenoid controlled latches holding the beacons in place in the tubes are constructed and arranged so as not to be affected by sea water present in the tubes.

In a further arrangement according to the invention, the container of the beacon itself is constructed to serve as the transmitting aerial for the beacon, that is the dome of the beacon embodies the aerial. The dome could also be provided with a gas-filled balloon which is deployed automatically once the beacon reaches the surface of the sea to enable a radio signal to be transmitted over a greater range.

Claims

1. An underwater communications device comprising an enclosure, means to anchor the enclosure to the sea bed, sonar listening equipment in the enclosure for receiving sonar signals from the surrounding water, a plurality of communication beacons enclosed in individual buoyant containers, means for releasably holding the beacons in the enclosure and means for releasing a beacon from the enclosure in response to receipt of a sonar signal by said sonar receiving means to allow the beacon to surface and transmit signals pursuant to the receipt of said sonar signal.
2. An apparatus as claimed in Claim 1, wherein the sonar receiving apparatus includes means to store different sonar signals emitted by different surface or underwater vessels whether hostile or friendly, means to receive and compare a sonar signal with said stored sonar signals and means to initiate release of a beacon in response to any sonar signal identified as being that of a hostile vessel to transmit a signal indicating the presence of a hostile vessel.
3. Apparatus as claimed in Claim 2, wherein the sonar receiving equipment apparatus is arranged to supply information to the beacon including the identity of the vessel detected to be transmitted by said beacon after release of the beacon from the enclosure and on reaching the surface.

4. Apparatus as claimed in any of the preceding claims, wherein said beacons embody radio transmitters for transmitting radio signals on surfacing indicating the detection of a "hostile" vessel. 5
5. Apparatus as claimed in any of the preceding claims, wherein means are provided for communicating with one or more remote weapon systems for activating the weapon systems to be used against a target detected by the sonar equipment. 10
6. An apparatus as claimed in any of the preceding claims wherein the enclosure has an upper body part containing the sonar equipment and said beacons and a lower body part having means to bury the lower body part in the sea bed. 15

Patentansprüche

1. Eine Unterwasserverbindungs Vorrichtung, die folgendes enthält: Einen Behälter, Mittel zur Verankerung des Behälters im Meeresboden, Sonarhorchgerät in dem Behälter für den Empfang von Sonarsignale von dem umgebenden Wasser, mehrere Verkehrssender, die in individuellen Behältern mit Auftrieb verschlossen sind, Mittel für die Festhaltung der Sender im Behälter, so dass sie freigemacht werden können, und Mittel für die Freimachung eines Senders von dem Behälter als Folge des Empfangs eines Sonarsignals durch das erwähnte Sonargerät, um es dem Sender zu ermöglichen, die Wasseroberfläche zu erreichen und Signale nach dem Empfang des erwähnten Sonarsignals auszusenden. 20 25 30 35
2. Ein Apparat wie im Anspruch 1 gefordert, in welchem der Sonarempfangsapparat folgendes enthält: Mittel zum Speichern von verschiedenen Sonarsignalen, die von verschiedenen Überwasser- und Unterwasserfahrzeugen (feindliche oder freundliche) ausgestrahlt werden, Geräte für den Empfang und den Vergleich eines Sonarsignals mit den erwähnten gespeicherten Sonarsignalen und Geräte um die Freimachung eines Senders zu bewerkstelligen in Verbindung mit dem Empfang jeden Sonarsignals, das als von einem feindlichen Fahrzeug kommend identifiziert wird, um ein Signal zu senden, das die Anwesenheit eines feindlichen Fahrzeuges meldet. 40 45 50 55
3. Apparat, wie in Anspruch 2, in dem das Sonarempfangsgerät so gestaltet ist, dass es Information an den Sender leistet, sowie die Identi-

tät des entdeckten Fahrzeuges, um von dem erwähnten Sender weitergesendet zu werden, nachdem der Sender vom Behälter freigemacht worden ist und die Oberfläche erreicht hat.

4. Apparat, wie in vorher erwähnten Ansprüchen gefordert, in welchem die erwähnten Sender Radiosender für die Sendung von Radiosignalen enthalten, die, wenn die Oberfläche erreicht, die Entdeckung eines "feindlichen" Fahrzeuges melden.
5. Apparat, wie in vorher erwähnten Ansprüchen gefordert, in dem Mittel für den Verkehr mit einem oder mehreren entfernten Waffensystemen enthalten sind, um die Waffensysteme für den Gebrauch auf ein Ziel zu aktivieren, das vom Sonargerät entdeckt worden ist.
6. Ein Apparat, wie in vorher erwähnten Ansprüchen gefordert, in dem der Behälter einen oberen Teil hat, der das Sonargerät und die erwähnten Sender enthält, und einen unteren Teil, der mit Geräten für das Vergraben des unteren Teils in den Meeresboden versehen ist.

Revendications

1. Dispositif de communication sous-marine comprenant une enceinte, un moyen d'ancrage de l'enceinte au fond de la mer, un équipement d'écoute sonar dans l'enceinte pour recevoir des signaux sonar provenant de l'eau environnante, une pluralité de balises de communication enfermées dans des conteneurs flottants, un moyen pour maintenir la balise dans l'enceinte, de façon à pouvoir la larguer, et un moyen pour larguer une balise de l'enceinte en réponse à la réception d'un signal sonar par ledit moyen récepteur sonar pour permettre aux balises de faire surface et d'émettre des signaux conformément à la réception dudit signal sonar.
2. Dispositif selon la revendication 1, dans lequel le dispositif récepteur sonar comprend un moyen pour mémoriser des signaux sonar différents émis par des navires de surface ou sous-marins différents suivant qu'ils sont hostiles ou amis, un moyen pour recevoir et pour comparer un signal sonar avec lesdits signaux sonar mémorisés et un moyen pour initialiser le largage d'une balise en réponse à un signal sonar quelconque identifié comme étant celui d'un navire hostile, pour émettre un signal indiquant la présence d'un navire hostile.

3. Dispositif selon la revendication 2, dans lequel le dispositif récepteur sonar est conçu pour délivrer à la balise une information incluant l'identité du navire détecté pour qu'elle soit émise par ladite balise après largage à partir de l'enceinte et au moment où elle fait surface. 5
4. Dispositif selon l'une quelconque des revendications précédentes, dans lequel lesdites balises incorporent des émetteurs radio pour émettre, lorsqu'elles font surface, des signaux radio indiquant la détection d'un navire "hostile". 10
5. Dispositif selon l'une quelconque des revendications précédentes, dans lequel il est prévu des moyens pour communiquer avec un ou plusieurs systèmes d'armes situés à distance pour actionner le système d'arme à utiliser contre une cible détectée par l'équipement sonar. 15 20
6. Dispositif selon l'une quelconque des revendications précédentes, dans lequel l'enceinte a une partie corps supérieur contenant l'équipement sonar et lesdites balises et une partie corps inférieur contenant un moyen pour enter- 25
rer la partie corps inférieur dans le fond de la mer. 30

30

35

40

45

50

55

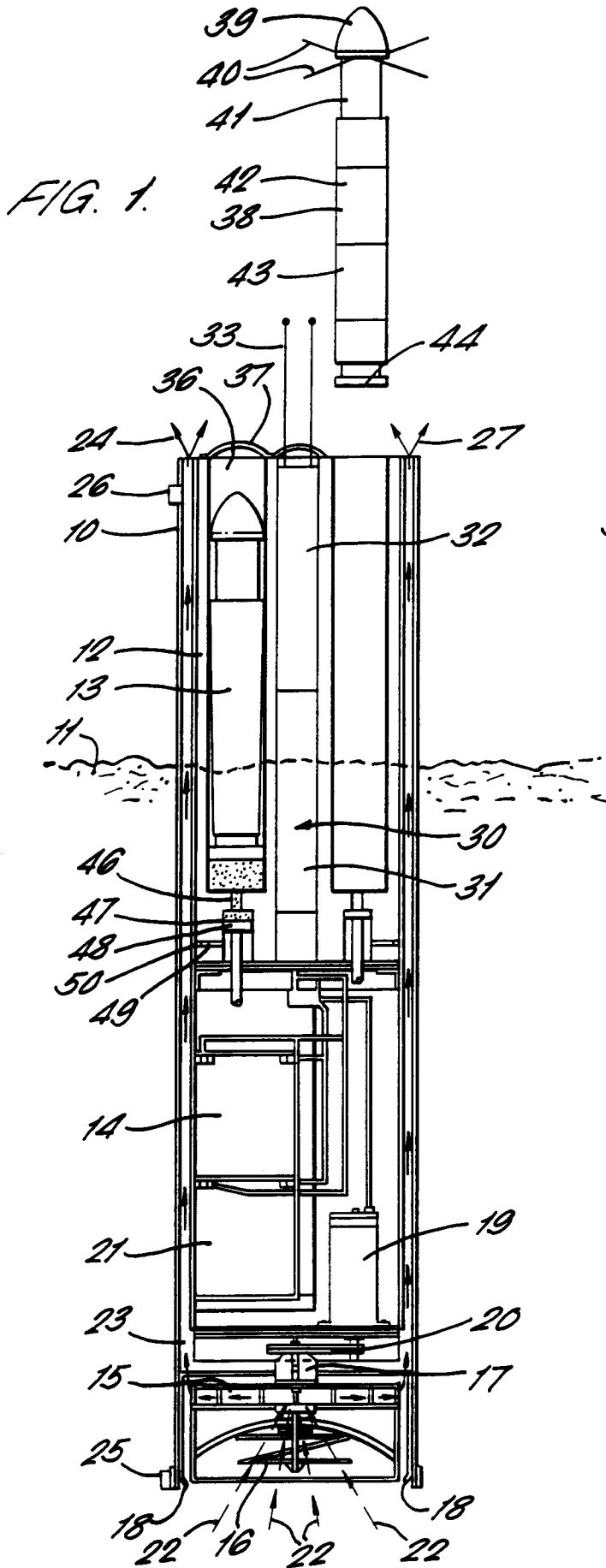

FIG. 2.

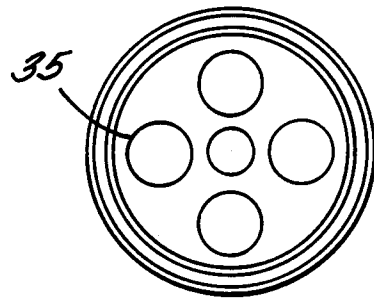

FIG. 3.

