

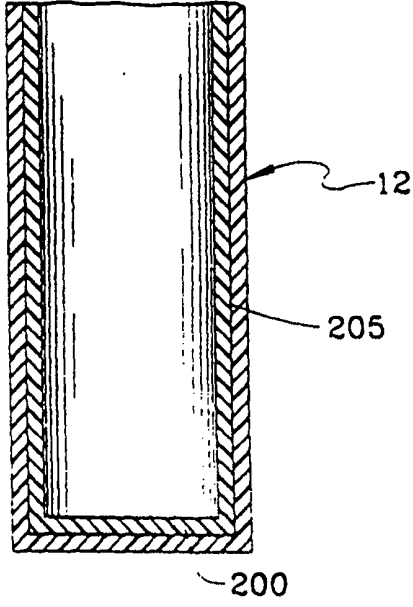

INTERNATIONAL APPLICATION PUBLISHED UNDER THE PATENT COOPERATION TREATY (PCT)

<p>(51) International Patent Classification⁶ : B29D 22/00</p>	<p>A1</p>	<p>(11) International Publication Number: WO 99/62697</p> <p>(43) International Publication Date: 9 December 1999 (09.12.99)</p>
<p>(21) International Application Number: PCT/US99/11565</p> <p>(22) International Filing Date: 25 May 1999 (25.05.99)</p> <p>(30) Priority Data: 09/090,635 4 June 1998 (04.06.98) US</p> <p>(71) Applicant: CAPITOL SPECIALTY PLASTICS, INC. [US/US]; 2039 McMillan Street, Auburn, AL 36832 (US).</p> <p>(72) Inventor: HEKAL, Ihab, M.; 121 Blackberry Drive, Stamford, CT 06903 (US).</p> <p>(74) Agent: SCHINDLER, Barry, J.; Dreier & Baritz LLP, 20th floor, 499 Park Avenue, New York, NY 10022 (US).</p>		<p>(81) Designated States: AU, BR, CA, CN, JP, NO, NZ, European patent (AT, BE, CH, CY, DE, DK, ES, FI, FR, GB, GR, IE, IT, LU, MC, NL, PT, SE).</p> <p>Published <i>With international search report.</i></p>
<p>(54) Title: DESICCANT BLENDED IN A THERMOPLASTIC</p>		
<p>(57) Abstract</p>		
<p>The present invention relates to a package or container (01) having desiccating abilities. The package or container (01) includes an insert (200) in the shape of a plug, film, sheet or pellet having desiccating abilities that is included in the package or container (01). Alternatively, the insert (200) may be molded within the body (12) of the package or container. The insert (200) is formed by blending a desiccant and thermoplastic.</p>		

FOR THE PURPOSES OF INFORMATION ONLY

Codes used to identify States party to the PCT on the front pages of pamphlets publishing international applications under the PCT.

AL	Albania	ES	Spain	LS	Lesotho	SI	Slovenia
AM	Armenia	FI	Finland	LT	Lithuania	SK	Slovakia
AT	Austria	FR	France	LU	Luxembourg	SN	Senegal
AU	Australia	GA	Gabon	LV	Latvia	SZ	Swaziland
AZ	Azerbaijan	GB	United Kingdom	MC	Monaco	TD	Chad
BA	Bosnia and Herzegovina	GE	Georgia	MD	Republic of Moldova	TG	Togo
BB	Barbados	GH	Ghana	MG	Madagascar	TJ	Tajikistan
BE	Belgium	GN	Guinea	MK	The former Yugoslav Republic of Macedonia	TM	Turkmenistan
BF	Burkina Faso	GR	Greece	ML	Mali	TR	Turkey
BG	Bulgaria	HU	Hungary	MN	Mongolia	TT	Trinidad and Tobago
BJ	Benin	IE	Ireland	MR	Mauritania	UA	Ukraine
BR	Brazil	IL	Israel	MW	Malawi	UG	Uganda
BY	Belarus	IS	Iceland	MX	Mexico	US	United States of America
CA	Canada	IT	Italy	NE	Niger	UZ	Uzbekistan
CF	Central African Republic	JP	Japan	NL	Netherlands	VN	Viet Nam
CG	Congo	KE	Kenya	NO	Norway	YU	Yugoslavia
CH	Switzerland	KG	Kyrgyzstan	NZ	New Zealand	ZW	Zimbabwe
CI	Côte d'Ivoire	KP	Democratic People's Republic of Korea	PL	Poland		
CM	Cameroon	KR	Republic of Korea	PT	Portugal		
CN	China	KZ	Kazakstan	RO	Romania		
CU	Cuba	LC	Saint Lucia	RU	Russian Federation		
CZ	Czech Republic	LI	Liechtenstein	SD	Sudan		
DE	Germany	LK	Sri Lanka	SE	Sweden		
DK	Denmark	LR	Liberia	SG	Singapore		
EE	Estonia						

DESICCANT BLENDED IN A THERMOPLASTIC

FIELD OF INVENTION:

The present invention relates to packages having desiccating abilities. More particularly, the present invention relates to a thermoplastic having a desiccant blended therein.

BACKGROUND OF THE INVENTION:

There are many articles that are preferably stored, shipped and/or utilized in an environment that is as moisture free as possible. Therefore, containers and/or packages having the ability to absorb excess moisture trapped therein have been recognized as desirable. One application in which moisture absorbing containers are desired is for the shipment and storage of medications whose efficacy is compromised by moisture. The initial placement of medicines into a sealed moisture free container is usually controllable. Furthermore, the container for the medicine is selected so that it has a low permeability to moisture. Therefore, the medication will normally be protected from moisture until it reaches the end user. Once the medicine is received by the customer, however, the container must be repeatedly opened and closed to access the medication. Each time the container is opened and unsealed, moisture bearing air will most likely be introduced into the container and sealed therein upon closure. Unless this moisture is otherwise removed from the atmosphere or head space of the container, it may be detrimentally absorbed by the medication. For this reason, it is a well known practice to include a desiccating unit together with the medication in the container.

In other instances, moisture may be released from items that have been placed in containers or sealed in packaging wrap for shipping and/or storage. Prime examples of such items are food stuffs that release moisture during shipping and storage. In the instance of containers that are sealed and substantially impermeable to moisture, the released moisture will remain within the container. If not removed, this released moisture may have ill effects on the very item that released the moisture. It has been found that a substantial amount of moisture is released from certain food products within the first forty-eight (48) hours after manufacture and packaging. This released moisture will remain until removed. If the moisture is not removed shortly after its release, it may cause the food to degrade into a condition that is not saleable and/or useable. In these cases, desiccants may be included together with the contained item or items to continually absorb the released moisture until the product is unpacked. In this way, a relatively dry environment is maintained about the stored item.

The need to eliminate moisture from within sealed containers has been previously recognized. Early attempts to achieve these goals included the provision of desiccant materials in fabric or similar bags that are placed in the containers together and commingled with the matter being shipped or stored. A consumer related problem, however, exists when the desiccant is loose and commingled together with consumable items. If not carefully and thoroughly

1 processed upon unpacking, the desiccant may not be separated from the consumables and could
2 harm a person if unknowingly ingested.

3 Another known mode by which a desiccant may be provided within a container includes
4 coating the interior surface of the container vessel with a desiccant bearing material. Still further,
5 it is known to provide desiccating abilities in a container through the use of layered structures in
6 which a desiccant is "sandwiched" between moisture permeable material that confines the
7 desiccant. These layered structures often take the form of flexible sheeting that may be formed
8 into bag type containers into which items requiring a reduced moisture environment are placed.

9 Several of the known means by which desiccant bearing containers are constructed
10 require multiple steps and result in more complex and layered structures than are desired.
11 Furthermore, the provision of desiccant capsules together with contained items is not always
12 satisfactory. As previously explained, commingling of desiccant with food items and
13 medications is undesirable from a consumer stand point in that the desiccant may be
14 inadvertently ingested. Still further, if the desiccant is not integrally constructed with the
15 container, or at least attached thereto, it may be prematurely removed while still needed for
16 continued removal of moisture from within the container. Therefore, a need has been recognized
17 for containers that include a desiccant as an integral component of the container's body or
18 package. Regarding the included desiccant of the container, it is desired to enhance its
19 capabilities of moisture absorption with respect to both rate and quantity. Still further, as in all
20 manufacturing processes, it is desired to reduce the required steps for constructing desiccating
21 containers and simplify the resulting structures.

22 SUMMARY OF THE INVENTION:

23 In one embodiment of the present invention, a container, and process for constructing
24 the container is provided that satisfies the need for more effective desiccating storage and
25 shipping containers. The containers of the present invention provide superior desiccating
26 abilities, while at the same time permitting efficient construction of a container that has and
27 maintains structural integrity. Furthermore, the present invention provides a means by which the
28 container may be formed having a substantially unitized and continuous body. In another
29 embodiment, the present invention may be used to form an insert, integral or non-integral, for the
30 container or package in the form of a shaped article such as a sheet, film, or pellets, for example,
31 in the base or bottom of the container and not capable by itself of containing the contents of the
32 container.

33 BRIEF DESCRIPTION OF DRAWINGS:

34 Figure 1 is a cross-sectional view of a desiccating container with an insert in the form of
35 a disc molded therein.

36 Figure 2 is a cross-sectional view of a desiccating container with an insert in the form of
37 a liner molded therein.

1 Figure 3 is a partial cross-sectional view of the container body showing a lip retainer.

2 Figure 4 is a side view of a mold in partial section mounted upon a rotatable table for
3 transport between injection stations and showing a container and insert molded therein.

4 Figure 5 is a side view of a mold in partial section showing a container and insert
5 molded therein in a single station configuration with two injection ports.

6 Figure 6 is a schematic of the method by which the container is co-molded.

7 Among those benefits and improvements that have been disclosed, other objects and
8 advantages of this invention will become apparent from the following description taken in
9 conjunction with the accompanying drawings. The drawings constitute a part of this
10 specification and include exemplary embodiments of the present invention and illustrate various
11 objects and features thereof.

12 DETAILED DESCRIPTION OF THE INVENTION:

13 As required, detailed embodiments of the present invention are disclosed herein;
14 however, it is to be understood that the disclosed embodiments are merely exemplary of the
15 invention that may be embodied in various forms. The figures are not necessarily to scale, some
16 features may be exaggerated to show details of particular components. Therefore, specific
17 structural and functional details disclosed herein are not to be interpreted as limiting, but merely
18 as a basis for the claims and as a representative basis for teaching one skilled in the art to
19 variously employ the present invention.

20 The presently disclosed invention includes and is applicable to the manufacture of
21 similar containers. The containers 01 disclosed herein, however, are not limited to vials. It is
22 contemplated that containers 01 constructed according to the present invention may be larger or
23 smaller than the vials of 4,783,056 and of variable shape. Furthermore, the caps 14 may be
24 integrally formed with the bodies 12 of the containers 01, or they may be manufactured as
25 separate units. Still further, the present invention may be embodied exclusively within the body
26 of a container 12 or a cap 14 for a container 01.

27 The material used in the construction of these containers 01 typically provides a barrier
28 between the interior 201 and exterior 202 of the container 01 that is substantially moisture
29 impermeable and most often is a thermoplastic. While it is contemplated that any thermoplastic
30 may be utilized, polypropylene is preferred for the construction of the body 12 of the container
31 01. Polypropylene is desirable because of its durability, rigidity and resistance to breakage after
32 being molded into the form of a container 01. Examples of suitable thermoplastics may be
33 selected from the following groups: polyolefin, polyethylene, polycarbonate, polyamide,
34 ethylene-vinyl acetate copolymer, ethylene-methacrylate copolymer, polyvinyl chloride,
35 polystyrene, polyester, polyester amide, polyacrylic ester, and polyvinylidene chloride, acrylic,
36 polyurethane, polyacetal, and polycarbonate. These and other thermoplastics may be utilized
37 either singularly, or in combinations.

1 The present invention includes the manufacture of a container 01 in which the majority
2 of the container's body 12 is constructed from the base thermoplastic, e.g. polypropylene,
3 because of its durability and resistance to breakage. To establish and/or increase a desiccating
4 capacity of the molded container 01, an insert 200 that has been formed from a desiccant
5 entrained thermoplastic is integrally constructed with the body 12 of the container 01. The heat
6 molded insert of the present invention consists essentially of the thermoplastic material with the
7 entrained desiccant. The term "consisting essentially of" is used herein to denote that the molded
8 insert may contain other materials so long as they do not materially effect the moisture removal
9 properties of the insert. For example, the heat molded insert may have also entrained carbon
10 black or other coloring agents to provide color or other aesthetic properties to the insert.

11 The concentration of desiccant entrained (e.g. mixed or blended) within the insert 200
12 may exceed seventy-five percent (75%) to not greater than eighty percent (80%) by weight, so
13 that about seventy-five percent (75%) may extend to eighty percent (80%) by weight. Typically,
14 however, the desiccant concentration in the insert 200 will fall within a range of forty to seventy-
15 five (40-75%) desiccant to thermoplastic, by weight. This concentration is considered to be a
16 high concentration for most thermoplastics. The maximum desiccant bearable concentrations
17 will vary among the various types of thermoplastics due to their differing characteristics. In the
18 instance of polyethylene or polypropylene, for example, the maximum concentration of desiccant
19 will be about seventy-five percent (75%) by weight. As the desiccant concentrations within the
20 thermoplastics increase, the performance of the material degenerates to unacceptable levels. At
21 lower levels of desiccant concentrations, about forty percent (40%) could extend to as low as
22 thirty percent (30%) where the limits of a viable product are reached.

23 In one embodiment, the insert 200 is located in the base or bottom 203 of the container
24 body 12 and is exposed to the interior space 201 of the container 01. The configuration of this
25 embodiment is similar to a sample vial. Because the durability and resistance to breakage is
26 lessened in the higher ranges of desiccant content, it is advantageous to have the polypropylene
27 used in the construction of the container's body 12 formed about the insert 200 except for at
28 those surfaces to be exposed to the interior 201 of the container 01. A container 01 of this
29 configuration provides desired structural integrity while also providing the greater desiccating
30 ability of the high desiccant laden insert 200 that is directly exposed to the interior 201 of the
31 container 01. It is also contemplated that the insert 200 may be included in the construction of
32 the container's cap 14. In this case, the insert will be integrally formed with the cap 14 so that an
33 exterior surface of the insert 200 is exposed to the interior 201 of the container 01 when installed
34 thereupon.

35 As a further alternative embodiment, the insert 200 may be less localized, and extended
36 to a greater degree about a greater portion of the interior surface 204 of the container body 12. In
37 this instance, the high desiccant bearing thermoplastic forms more of a liner 205 at the interior

1 surface 204 of the container 01. To provide maximum desiccating abilities, the liner 205 may
2 completely cover the interior surface 204 of the container 01; this may optionally include the
3 interiorly exposed surfaces of a cap 14 of a closed container 01.

4 One contemplated method for the manufacture of the container 01 includes the
5 provision of a performed insert 200 about which the thermoplastic of the remainder of the body
6 12 of the container 01 is injection molded. In this process, it is important that the insert 200 be
7 affixed to or within the body 12 of the container 01. This may be achieved merely by molding
8 the body 12 about the insert 200 so that the two components are mechanically connected one to
9 the other. The mechanical connection may take the form of a retaining lip 206 formed by the
10 container body 12 about the insert 200 that effectively fixes the insert 200 with respect to the rest
11 of the body 01.

12 As shown by the various embodiments of the present invention, the insert of the present
13 invention is formed by heat molding the desiccant entrained thermoplastic of the present
14 invention. For example, the insert may be heat molded using any conventional technique such as
15 co-extruding, extrusion blow moulding, injection blow molding, reaction injection moulding or
16 extruding.

17 Alternatively, it is also contemplated that a "shrink-fit" may be achieved by the body 12
18 forming thermoplastic about the insert 200. A particular example of this shrink-fit application
19 would be the provision of a desiccant loaded insert 200 constructed from a base thermoplastic of
20 polyethylene and a container body 12 molded thereabout from a base thermoplastic of
21 polypropylene. Upon cooling after being injection molded, polyethylene shrinks less than
22 polypropylene under similar circumstances. Therefore, if a polypropylene body is injection
23 molded about a polyethylene insert 200 that has been either previously formed, or is injection
24 molded contemporaneously with the container body 12, the polypropylene container body 12 will
25 shrink about the polyethylene insert 200. This shrink-fit method may be implemented whether or
26 not the insert 200 is relatively small and localized with respect to the container body 12 or
27 whether or not the insert 200 is relatively small and localized with respect to the container body
28 12 or whether the insert 200 takes the form of a previously described liner 205 configuration. In
29 either case, the exteriorly formed container body 12 may shrink about the insert 200 if the
30 thermoplastics from which the insert 200 and container body 12 are appropriately selected. The
31 use of the retaining lip 206 and shrink-fit method of affixing the insert 200 or liner 205 to the
32 container body 12 is used primarily when the materials of construction of the insert 200 and
33 container body 12 are not compatible. The two components will be considered incompatible if
34 they do not automatically adhere one to the other as a result of the manufacturing process.

35 Alternatively, the insert 200 will be constructed from a material that bonds to the body
36 12 of the container 01 when the body 12 is placed thereabout. Therefore, one method for
37 constructing the insert 200 bearing container 01 of the present invention is co-molding. That is,

1 the primary body 12 of the container 01 is molded, while the high desiccant insert 200 is also
2 molded. The two portions are said to be co-molded because they are either simultaneously or
3 sequentially injection molded in a single process. The process of co-molding results in the
4 construction of a unitized container body 12 in which the insert 200 is seamlessly combined with
5 the body 12. In most instances, the insert 200 and container body 12 adhere one to the other as a
6 result of a melding together of the base thermoplastics from which each is constructed at an
7 interface therebetween. The melding action takes place when the insert 200 and container body
8 12 are each injected into the mold 10 sufficiently closely with respect to time so that each is in at
9 least a semi-molten state while in contact one with the other. Alternatively, heat from the
10 thermoplastic of a body 12 injected about an insert 200 may cause the contacted portions of the
11 insert 200 to melt slightly and meld with the thermoplastic of the body 12 adjacent thereto. In
12 each case, there will be a phase between the high desiccant concentrate insert 200 and container
13 body 12 in which the two construction materials blend to some degree creating a seamless
14 interface and therefore unitized container 01 out of the two components.

15 In any event, the thermoplastic in which the desiccant is entrained is moisture
16 permeable to the degree that moisture from the interior 201 of the container 01 may be
17 transferred to and stored in the desiccant. It is possible that the thermoplastic from which the
18 insert 200 is manufactured may have a higher moisture permeability than that from which the
19 remainder of the body 12 of the container 01 is constructed. In this case, the insert 200 may be
20 enclosed within the container 01 by a lower moisture permeable thermoplastic of the container's
21 body 12. In this way, moisture will not readily be transferred from outside the container 01 to the
22 interior. In view of the possibility of desiring differing moisture permeabilities in the insert 200
23 and the container body 12, it is contemplated that the two components 200, 12 may be
24 constructed from different materials that are potentially incompatible.

25 The process of the present invention in which the insert 200 is co-molded within the
26 primary body 12 of the container 01 may vary. In a first embodiment of the molding process, it
27 is contemplated that the mold 10 will move between two injection stations. An injection
28 assembly that is generally designated by reference numeral 96 may be installed and withdrawn
29 from the mold frame 24. At one station, typically the first station, the insert 200 will be injection
30 molded. In order to mold the insert 200, a ring shaped barrier will be provided that has a
31 circumference substantially matching the perimeter of a lower end of core 48. It is desired that
32 the thickness of the insert 200 be approximately one-eighth of an inch, therefore the thickness or
33 height of the barrier ring will likewise be one-eighth of an inch. As the injection assembly 96 is
34 installed within the mold frame 24, the barrier ring is the leading component. The ring contacts
35 the lower surface of the core 48 forming a barrier within which thermoplastic may be injected.
36 High concentrate desiccant thermoplastic is then injected into the interior of the ring thereby
37 forming the insert 200. The high concentrate desiccant thermoplastic of the insert 200 may be

1 injected at a temperature that is less than the temperature at which the thermoplastic of the
2 container body 12 is injected. The lowered temperature may be required so that the desiccant
3 contained therein does not degrade. The necessity of the lowered temperature may be obviated
4 by using different and/or high-grade desiccants that are not susceptible to degradation within the
5 normal temperature ranges of the injection process.

6 It is anticipated that the rate of absorption into the insert 200 may be controlled by the
7 amount of surface area of the insert 200 exposed to the container's 01 interior 201. If greater
8 absorption rates are desired, more surface area of the insert 200 may be exposed. If it is desired
9 that a more prolonged absorption process be achieved, then less surface area will be exposed. It
10 is further contemplated that the rate of absorption by the insert 200 may be controlled by
11 encapsulation of the insert 200. If slower rates of absorption are desired, then the insert 200 can
12 be encased to greater degrees by the thermoplastic that forms the body 12 of the container 01 and
13 which is less permeable to moisture. The rate of absorption may also be controlled by using
14 different types of thermoplastics having different moisture permeability rates. Unless otherwise
15 specified, the moisture permeability rates of the thermoplastics of the present invention are
16 determined by ASTM test method F 1249-90, entitled "Standard Test Method for Water Vapor
17 Transmission Rate Through Plastic Film and Sheeting Using a Modulated Infrared Sensor."
18 Using ASTM F 1249-90 test method, the thermoplastics suitable for the present invention have a
19 moisture vapor transmission rate of less than about 30g/mil/100 in²/24 hours.

20 For example, polyethylene typically has a moisture vapor transmission rate of about 3
21 to about 5 gm per mil per 100 square inches per 24 hours. In one embodiment, the polyethylene
22 that is suitable in the present invention is made by Dow Chemical Co. and has a tradename of
23 polyethylene 4012. In another example, polypropylene homopolymer typically has a moisture
24 vapor transmission rate below 10 gm per mil per 100 square inches per 24 hours. In one
25 embodiment, the polypropylene that is suitable in the present invention is made by Exxon
26 Chemicals and has a tradename of Escoreneâ Polypropylene--PP 3505G. In a further example,
27 low density polyethylene butene copolymer typically has a moisture vapor transmission rate of
28 about 1 to about 2 gm per mil per 100 square inches per 24 hours. In one embodiment, the low
29 density polyethylene butene copolymer that is suitable in the present invention is made by Union
30 Carbide Corp. and has a tradename of GRSN-1539.

31 The amount of moisture that can be absorbed by the insert 200 may be controlled in
32 several ways. It is contemplated that the amount of moisture absorbable by the insert 200 may be
33 effected by changing the concentration of desiccant within acceptable ranges; the greater the
34 concentration, the greater the amount of moisture that can be captured.

35 In an alternative embodiment, the thermoplastic from which the body 12 is constructed
36 may also have desiccant entrained and suspended therein, but in lesser concentrations than the
37 insert 200. It has been found that the concentration of desiccant in the thermoplastic affects the

1 performance characteristics of the molded container 01. As an example, it has been found that
2 while the plastic will carry relatively high percentages of desiccant, desirable characteristics such
3 as durability and resistance to breakage may degrade at higher desiccant concentrations. It has
4 also been found that the plastic may be combined with lower concentrations of desiccant without
5 appreciably degrading the performance of the thermoplastic material in its molded and solid state.
6 In a typical application, a relatively low concentration will fall within the rate of five to fifteen
7 percent (5 - 15%) desiccant by weight to thermoplastic, with a preferred concentration being
8 approximately seven and one-half (7.5%). Additionally, for the purpose of the disclosure made
9 herein, desiccant-free thermoplastic may also be considered low concentration thermoplastic. In
10 another embodiment, the thermoplastic having the lower concentration of desiccant is molded
11 with the thermoplastic having the higher concentration of desiccant. That is, the primary body 12
12 of the container 01 is molded, while the high desiccant insert 200 is also molded. The two
13 portions are said to be co-molded. This process results in a unitized contained body 12.

14 Various concentrations of desiccant bearing thermoplastic are commercially available in
15 pellet form. Custom concentrations may be achieved by dry blending higher concentration
16 desiccant pellets with lower concentration or desiccant-free pellets of thermoplastic. When
17 blended in appropriate proportions, any desiccant concentration less than that of the high
18 concentration desiccant pellets may be accomplished. After the drying blending process, the
19 resulting mixture of pellets may be injection molded in a typical manner.

20 The type of desiccants that are suitable for use in the present invention obtain their
21 moisture adsorbing capabilities through physical adsorption. The adsorption process is
22 accomplished because of a fine capillary morphology of the desiccant particles which pulls
23 moisture therethrough. The pore size of the capillaries, as well as the capillaries' density
24 determine the absorption properties of the desiccant. Examples of these physical adsorption
25 desiccants include molecular sieves, silica gels, clays and starches. In several embodiments, the
26 molecular sieve pore sizes that are suitable for use in the present invention include between about
27 3 to 15 Angstroms; about 3 to 5 Angstroms, about 5 to 8; 3 Angstroms; 4 Angstroms; 5
28 Angstroms; 8 Angstroms and 10 Angstroms. In one embodiment, the pore size of silica gel is
29 about 24 Angstroms. Because these types of physical adsorption desiccants are both inert and
30 non-water soluble, they are preferred for many applications. Among other reasons, these
31 innocuous characteristics are particularly compatible with food products and medicinal products
32 such as pharmaceutical drugs and devices that may be enclosed within containers formed from
33 the desiccant entrained polymers, or at least exposed thereto. As stated previously, however, any
34 of the three types may be employed within the polymer bases of the present invention for the
35 purposes of producing a desiccant entrained polymer. Suitable desiccating agents of the present
36 invention include silica gel, molecular sieve and naturally occurring clay compounds which
37 would also include montmorillinite clay.

1 In another embodiment of the present invention, the desiccant that is suitable for use in
2 the present invention is zinc chloride. This type absorbs water or moisture and forms crystals of
3 a stable salt.

4 One of the many advantages of the present invention is that the molded insert can be
5 produced by mixing the components, heating and molding the mixture. The mixing conditions
6 are chosen so that the desiccant is sufficiently entrained by substantially uniformly blending in
7 the thermoplastic. For example, the components are mixed using a conventional mixer, for
8 example, a Henschel mixer. The present invention does not require further processing by
9 stretching (e.g. uniaxial or biaxial orientation method) or expanding (e.g. stretching at fast rates
10 then exposing the material to its crystalline melt point) to produce a porous material.

11 The present invention is particularly suited for applications where a product's (e.g.
12 pharmaceutical drug or device) efficacy may be compromised by a threshold amount of moisture.
13 Unless the moisture above this threshold amount is removed within a certain time period, this
14 moisture may detrimentally affect the product. The present invention solves this problem by
15 removing this excess moisture within the desired time period. This is achieved by the present
16 heat molded insert having a combination of: (a) a thermoplastic having certain moisture vapor
17 transmission rate characteristics; (b) a certain type of desiccant; (c) the insert having a certain
18 minimum and maximum weight % of desiccant; and (d) the insert having a minimum moisture
19 adsorption after 8 hours at 10% relative humidity ("Rh") without stretching or expanding. As a
20 result, the novel insert has previously unattained moisture adsorption in packaging applications.
21 Unless otherwise specified, the % Rh is measured at 72°F by the test method described in
22 Example 1.

23 Desiccant entrained plastic structures, and their constituent compounds have been
24 described herein. As previously stated, detailed embodiments of the present invention are
25 disclosed herein; however, it is to be understood that the disclosed embodiments are merely
26 exemplary of the invention that may be embodied in various forms. It will be appreciated that
27 many modifications and other variations that will be appreciated by those skilled in the art are
28 within the intended scope of this invention as claimed below without departing from the
29 teachings, spirit and intended scope of the invention.

30 The present invention will be illustrated in greater detail by the following specific
31 examples. It is understood that these examples are given by way of illustration and are not meant
32 to be limited to the disclosure or claims. For example, although the following examples were
33 tested at 10% and 55% Rh at 72°F, the insert of the present invention is also suited for other Rh
34 conditions. All percentages in the examples are elsewhere in the specification are by weight
35 unless otherwise specified.

36 EXAMPLE 1

1 This example illustrates a desiccant blended in a thermoplastic consisting essentially of
2 a thermoplastic of polypropylene (Exxon Chemicals, tradename Escoreneâ Polypropylene
3 3505G) and a desiccant of molecular sieve (Elf Atochem, tradename Siliporiteâ molecular sieves;
4 NK 10). The desiccant and thermoplastic were weighed to achieve the weight percent of each
5 shown in the table. The desiccant and thermoplastic were then mixed in a Henschel FM-200 high
6 intensity mixer. The material was then fed to a Leistritz twin screw extruder at a temperature in
7 the ten zones ranging from about 200° to 320°F, at about 400 rpm and at about 30 lbs./hr to
8 produce a pelletized material of about 1/8 inch diameter. The pelletized material was fed directly
9 to a hot roll press. A film was formed of desired thickness (10 mil).

10 The film was then evaluated for moisture adsorption of its total weight by using the
11 following test method (a) the environmental chamber was preset for 72°F and the desired
12 relative humidity ("Rh"); (b) the dish was weighed and the weight recorded; (c) the scale was
13 then tared to remove the weight of the dish from the balance; (d) the film was then added to the
14 weighed dish; (e) the material was then weighed and the weight recorded; (f) the weigh dish
15 with the sample was placed in the environmental chamber; (g) the sample was left in the
16 chamber for the desired time; (h) after the desired time was reached, the dish with the sample
17 was removed, re-weighed and the weight recorded; and (i) percent of moisture absorbed per
18 gram of material was calculated by:

$$19 \quad \frac{\text{final weight} - \text{original weight} * 100}{20 \quad \text{original weight}}$$

21
22

The results are presented in Table I.

TABLE I

% desiccant per total weight	% Moisture Adsorption			
	10% Rh		55%Rh	
	8hr	24 hr	8 hr	24 hr
10	.5	.8	.5	.6
20	.7	1.0	.7	1.3
30	.7	1.0	1.5	1.9
60	1.5	2.6	3	4.5
70	4	6	8	11.5

EXAMPLE 2

This example illustrates a desiccant blended in a thermoplastic consisting essentially of a thermoplastic of a low density polyethylene butene copolymer (Union Carbide, tradename 1137) and of a desiccant of molecular sieve (Elf Atochaem, tradename Siliporite[®] molecular sieves, NK10). The desiccant and thermoplastic were prepared in a manner similar to the method discussed in Example 1 to produce a pellet. The pellet was then formed into a film by using a platen press. The pellet was placed in the press between 2 sheets of Mylar film. The pellet was pressed at 425°F at 25 tons for about 15-20 seconds. The desired thickness was achieved by placing shims inside press. The film was removed and allowed to cool for about 15-20 seconds and then placed in a vacuum sealed brown bag. The film was also evaluated by the same method as discussed in Example 1. The results are presented in Table II.

TABLE II

% desiccant per total weight	Film Thickness (mil)	% Moisture Adsorption			
		10% Rh		55%Rh	
		8hr	24 hr	8 hr	24 hr
50	3.5	3	5.5	4.5	7
50	10	1.5	3	3	5
60	5	2.5	4.5	3.5	6.5
60	10	2	3.5	3	5
70	17	1	2	2	3
70	30	1	2	1.5	3
70	53	2	4	3.5	6.5
80	20	1	2	1.5	3
80	44	1.5	3	2	4
80	90	2	3	2.5	4

The previous examples demonstrate that an insert can be produced, within the scope of the present invention, by adjusting the following parameters: (a) type of thermoplastic; (b) desiccant loading level; (c) thickness of insert; and (d) type of desiccant.

1 1. A heat molded insert consisting essentially of desiccant entrained in thermoplastic
2 wherein: (a) the thermoplastic has a moisture vapor transmission rate of less than about 30 grams
3 per mil thickness per 100 square inches in area per 24 hours, (b) the desiccant is selected from the
4 group consisting of molecular sieve, silica gel, clay and zinc chloride, (c) the insert has between
5 about 40 and about 75 weight % of desiccant by weight of the desiccant and thermoplastic
6 content of the molded insert, and (d) the molded insert is capable of adsorbing without stretching
7 or expanding at least 1% moisture by weight of its total weight after 8 hours at 10% relative
8 humidity.

9 2. A heat molded insert as claimed in claim 1 wherein the molded insert is capable of
10 adsorbing without stretching or expanding at least 2.5% moisture by weight of its total weight
11 after 8 hours at 55% relative humidity.

12 3. The desiccant molded article of claim 1, wherein the thermoplastic is selected from
13 the group consisting of polyolefins, polycarbonates and polyamides.

14 4. The desiccant molded article of claim 2, wherein the thermoplastic is selected from
15 the group consisting of polyolefins, polycarbonates and polyamides.

FIG. 1

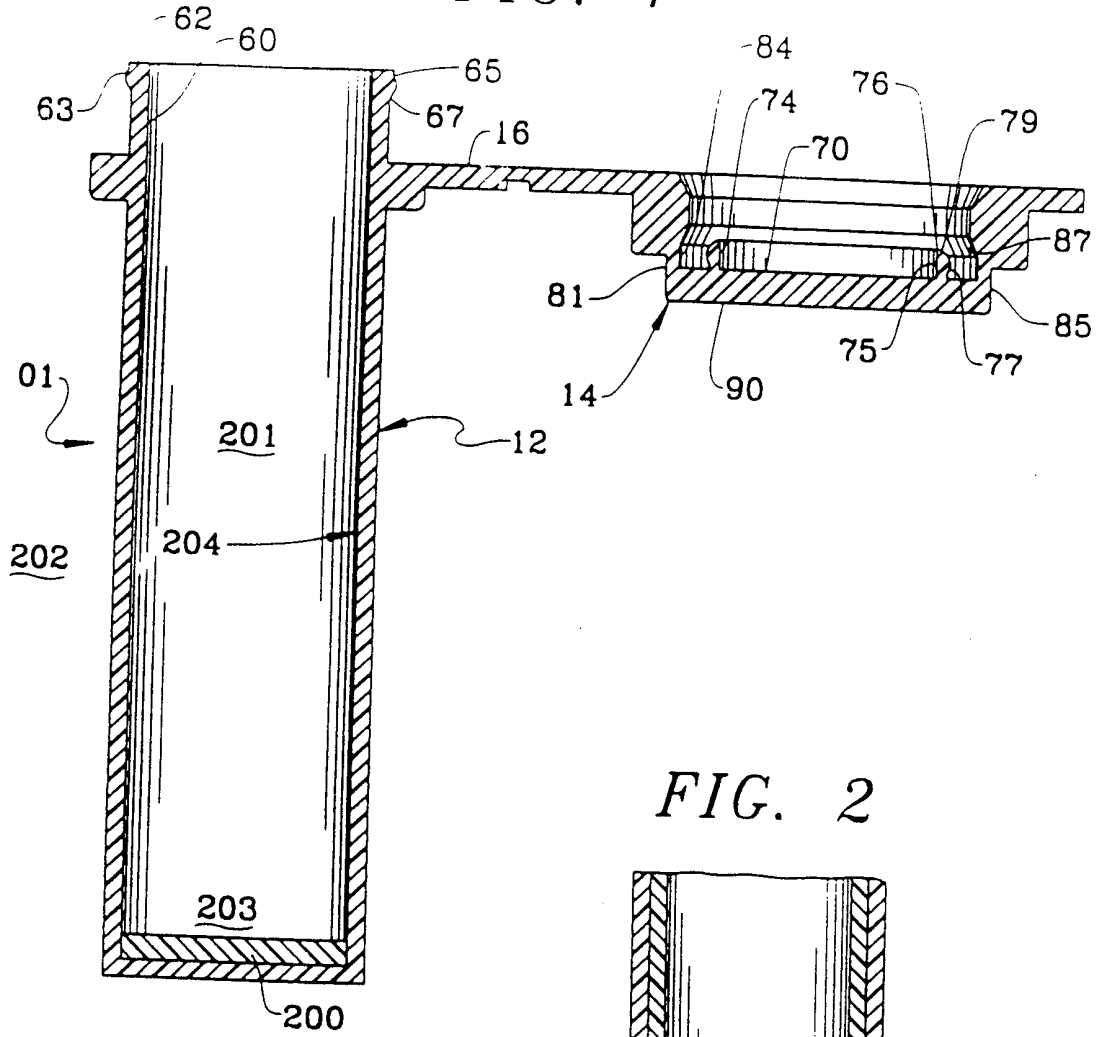

FIG. 2

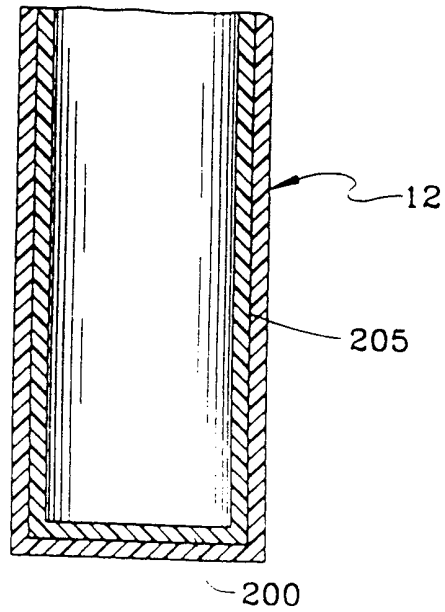

FIG. 3

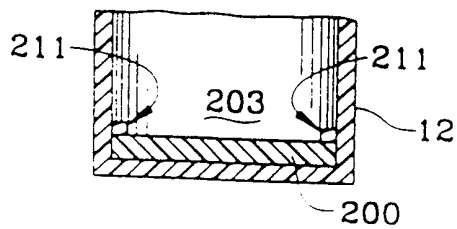

FIG. 4

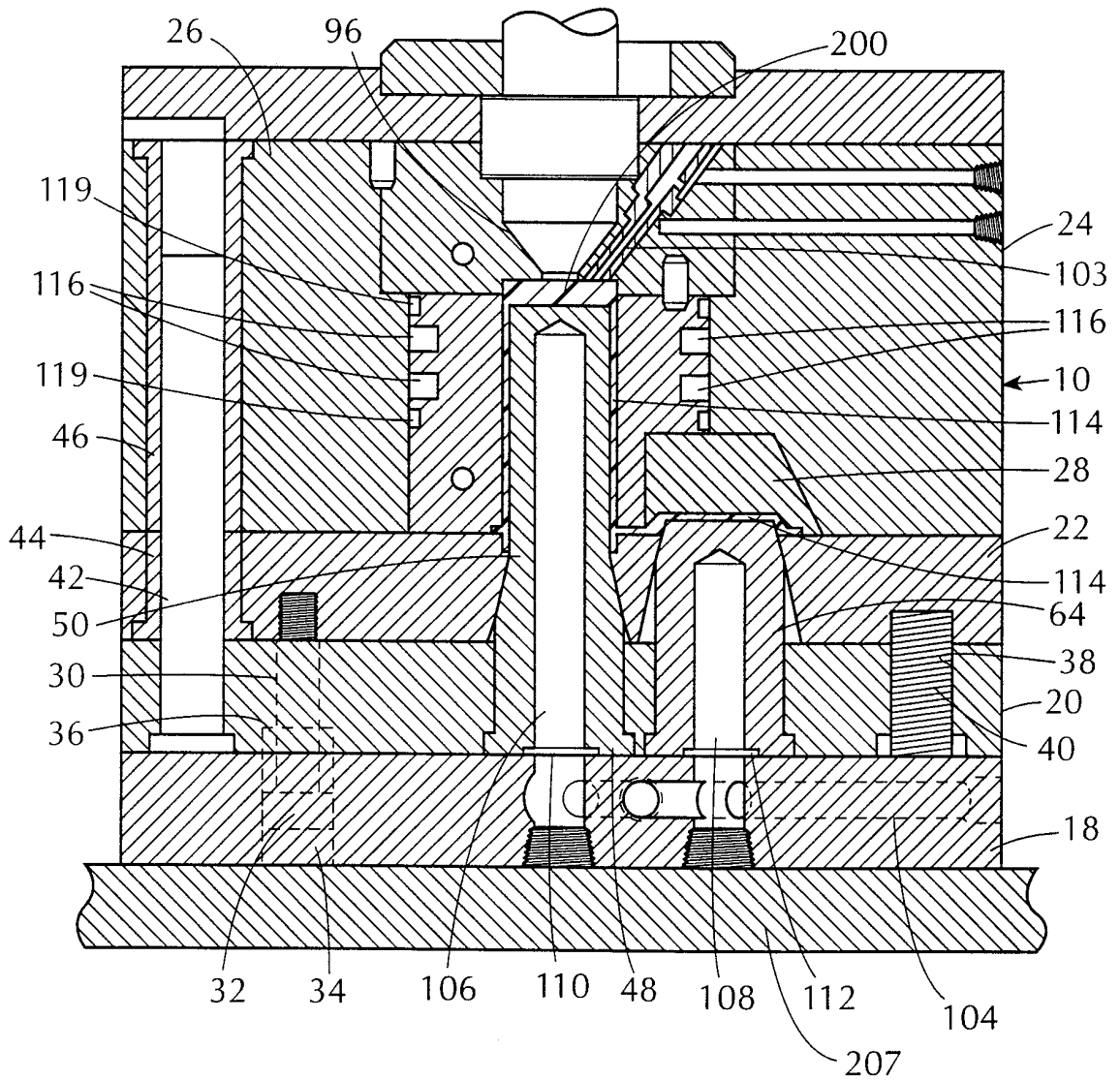

FIG. 5

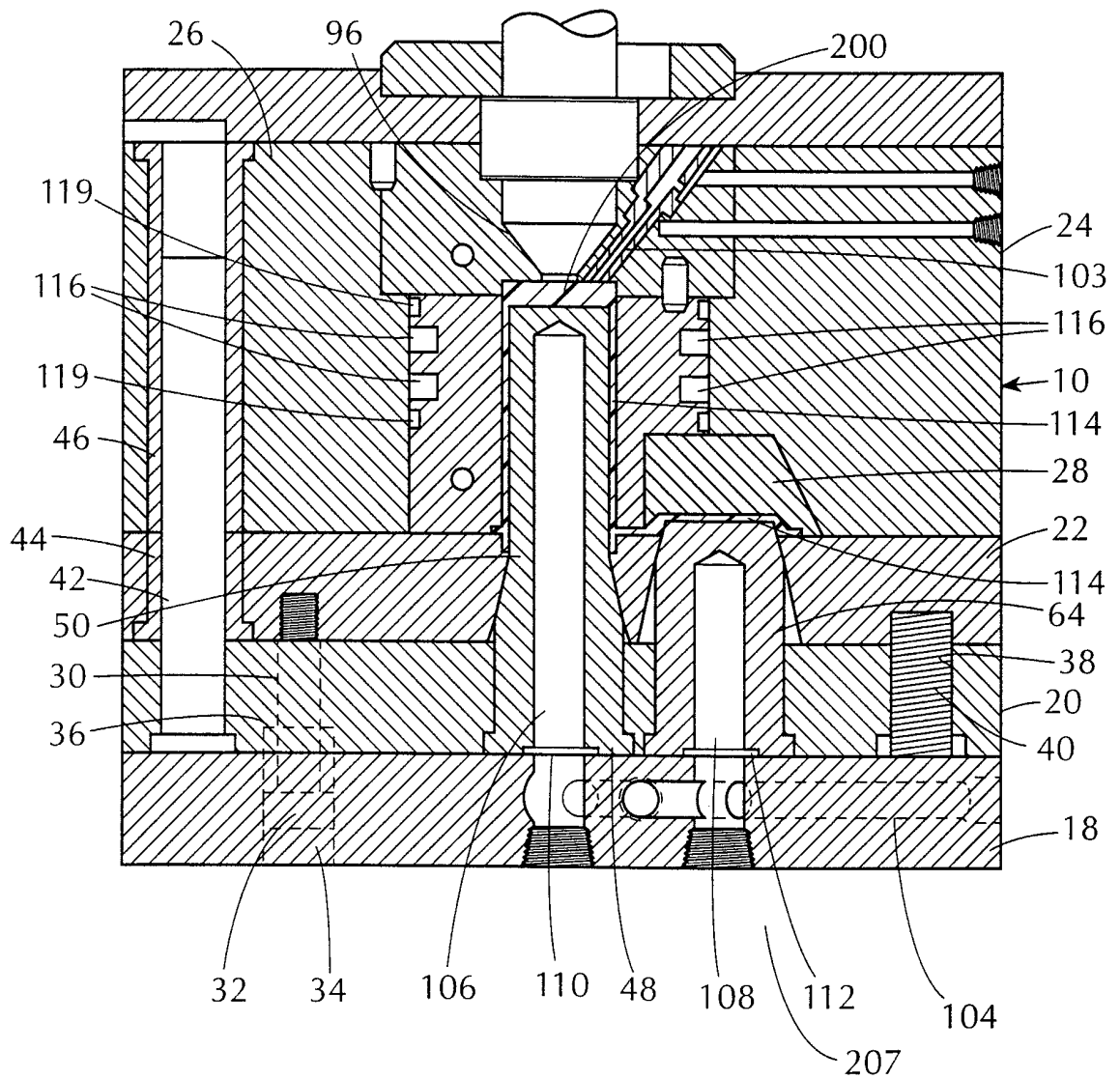
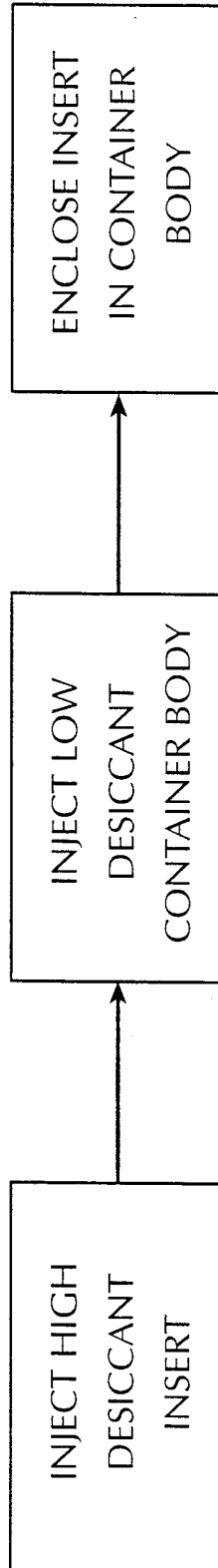

FIG. 6



INTERNATIONAL SEARCH REPORT

International application No.
PCT/US99/11565

A. CLASSIFICATION OF SUBJECT MATTER IPC(6) : B29D 22/00 US CL : 428/36.91 According to International Patent Classification (IPC) or to both national classification and IPC		
B. FIELDS SEARCHED Minimum documentation searched (classification system followed by classification symbols) U.S. : 428/36.4,36.91,500,412,474.5; 524/492,493,450, 445,447,434 Documentation searched other than minimum documentation to the extent that such documents are included in the fields searched Electronic data base consulted during the international search (name of data base and, where practicable, search terms used) Derwent APS		
C. DOCUMENTS CONSIDERED TO BE RELEVANT		
Category*	Citation of document, with indication, where appropriate, of the relevant passages	Relevant to claim No.
X	US 5,078,909 A (SHIGETA et al.) 07 January 1992 (07-01-92), abstract. ol 2, lines 63+.	1-4
X	US 5,432,214 A (LANCESSEUR) 11 June 1995 (11-06-95), col 1, lines 36-61).	1-4
A	US 5,304,419 A (SHORES) 19 April 1994 (19-04-94), abstract.	1-4
<input type="checkbox"/> Further documents are listed in the continuation of Box C. <input type="checkbox"/> See patent family annex.		
* Special categories of cited documents: "A" document defining the general state of the art which is not considered to be of particular relevance "E" earlier document published on or after the international filing date "L" document which may throw doubts on priority claim(s) or which is cited to establish the publication date of another citation or other special reason (as specified) "O" document referring to an oral disclosure, use, exhibition or other means "P" document published prior to the international filing date but later than the priority date claimed "T" later document published after the international filing date or priority date and not in conflict with the application but cited to understand the principle or theory underlying the invention "X" document of particular relevance; the claimed invention cannot be considered novel or cannot be considered to involve an inventive step when the document is taken alone "Y" document of particular relevance; the claimed invention cannot be considered to involve an inventive step when the document is combined with one or more other such documents, such combination being obvious to a person skilled in the art "a" document member of the same patent family		
Date of the actual completion of the international search 30 JUNE 1999		Date of mailing of the international search report 15 JUL 1999
Name and mailing address of the ISA/US Commissioner of Patents and Trademarks Box PCT Washington, D.C. 20231 Facsimile No. (703) 305-3230		Authorized officer KEVIN R. KRUER <i>Kevin R. Krueger</i> Telephone No. (703) 308-0661