

(19) World Intellectual Property
Organization
International Bureau



(43) International Publication Date
4 March 2004 (04.03.2004)

PCT

(10) International Publication Number
WO 2004/017865 A1

(51) International Patent Classification⁷: A61F 2/06

Great Britain SL4 2NF (GB). **ELICKER, Robert, John** [US/US]; 11 Azur, Santa Margarita, CA 92688 (US). **LABORDE, Jean-Claude** [FR/FR]; 1 chemin des coteaux, F-31320 Vieille-Toulouse (FR).

(21) International Application Number:
PCT/US2003/025988

(22) International Filing Date: 19 August 2003 (19.08.2003)

(74) Agent: **ALTMAN, Daniel, E.**; **KNOBBE, MARTENS, OLSON & BEAR, LLP**, 2040 Main Street, Fourteenth Floor, Irvine, CA 92614 (US).

(25) Filing Language: English

(26) Publication Language: English

(30) Priority Data:
10/225,484 20 August 2002 (20.08.2002) US

(81) Designated States (*national*): AE, AG, AL, AM, AT, AU, AZ, BA, BB, BG, BR, BY, BZ, CA, CH, CN, CO, CR, CU, CZ (utility model), CZ, DE (utility model), DE, DK (utility model), DK, DM, DZ, EC, EE, ES, FI (utility model), FI, GB, GD, GE, GH, GM, HR, HU, ID, IL, IN, IS, JP, KE, KG, KP, KR, KZ, LC, LK, LR, LS, LT, LU, LV, MA, MD, MG, MK, MN, MW, MX, MZ, NI, NO, NZ, OM, PG, PH, PL, PT, RO, RU, SC, SD, SE, SG, SK (utility model), SK, SL, SY, TJ, TM, TN, TR, TT, TZ, UA, UG, US, UZ, VC, VN, YU, ZA, ZM, ZW.

(71) Applicant (*for all designated States except US*): **DEVAX, INC.** [US/US]; 13700 Alton Parkway, Suite 164, Irvine, CA 92618 (US).

(72) Inventors; and

(75) Inventors/Applicants (*for US only*): **SEQUIN, Jacques** [FR/GB]; Riverway the Friary, Old Windsor, Berks,

(84) Designated States (*regional*): ARIPO patent (GH, GM, KE, LS, MW, MZ, SD, SL, SZ, TZ, UG, ZM, ZW),

[Continued on next page]

(54) Title: ENDOPROSTHESIS DEPLOYMENT SYSTEM FOR TREATING VASCULAR BIFURCATIONS

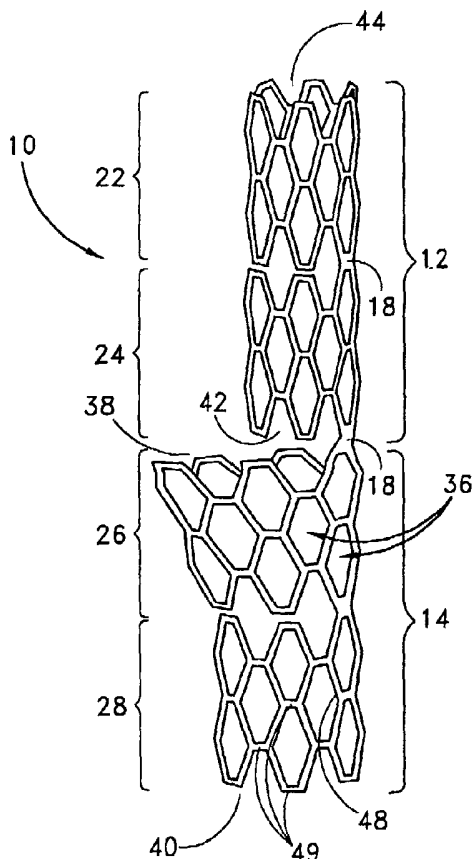

(57) Abstract: A device and method for treating pathological narrowing of fluid-carrying conduits of the human body (such as blood vessels) in an area of a bifurcation is disclosed. In particular, a stent system (10) comprising a pair of dissimilar stents (12, 14), one of which is particularly suited for treating a widened portion of a blood vessel immediately proximal to a bifurcation (30). A stent delivery system (100) including a handpiece (102) adapted to selectively deliver the stents (12, 14) is also disclosed.

WO 2004/017865 A1



Eurasian patent (AM, AZ, BY, KG, KZ, MD, RU, TJ, TM),
European patent (AT, BE, BG, CH, CY, CZ, DE, DK, EE,
ES, FI, FR, GB, GR, HU, IE, IT, LU, MC, NL, PT, RO,
SE, SI, SK, TR), OAPI patent (BF, BJ, CF, CG, CI, CM,
GA, GN, GQ, GW, ML, MR, NE, SN, TD, TG).

Published:

- *with international search report*
- *before the expiration of the time limit for amending the claims and to be republished in the event of receipt of amendments*

Declaration under Rule 4.17:

- *of inventorship (Rule 4.17(iv)) for US only*

For two-letter codes and other abbreviations, refer to the "Guidance Notes on Codes and Abbreviations" appearing at the beginning of each regular issue of the PCT Gazette.

ENDOPROSTHESIS DEPLOYMENT SYSTEM FOR TREATING VASCULAR BIFURCATIONS

Background

5 Scope of the Invention

The present invention relates to an apparatus permitting the treatment of bodily conduits, typically blood vessels, in an area of a bifurcation, e.g. in an area where a principal conduit separates into two secondary conduits. It also relates to equipment for positioning this apparatus.

10 Description of the Related Art

It is known to treat narrowing of a rectilinear blood vessel by means of a radially expandable tubular device, commonly referred to as a stent. This stent is introduced in the unexpanded state into the internal lumen of the vessel, in particular by the percutaneous route, as far as the area of narrowing. Once in place, the stent is expanded in such a way as
15 to support the vessel wall and thus re-establish the appropriate cross section of the vessel.

Stent devices can be made of a non-elastic material, in which case the stent is expanded by an inflatable balloon on which it is engaged. Alternatively, the stent can be self-expanding, e.g. made of an elastic material. A self-expanding stent typically expands spontaneously when withdrawn from a sheath which holds it in a contracted state.

20 For example, United States Patent Nos. 4,733,065 and 4,806,062 illustrate existing stent devices and corresponding positioning techniques.

A conventional stent is not entirely suitable for the treatment of a narrowing situated in the area of a bifurcation, since its engagement both in the principal conduit and in one of the secondary conduits can cause immediate or delayed occlusion of the other secondary
25 conduit.

It is known to reinforce a vascular bifurcation by means of a stent comprising first and second elements, each formed by helical winding of a metal filament. The first of the two elements has a first part having a diameter corresponding to the diameter of the principal vessel, and a second part having a diameter corresponding to the diameter of a
30 first one of the secondary vessels. The first element is intended to be engaged in the principal vessel and the second element is intended to be engaged in the first secondary vessel. The second element has a diameter corresponding to the diameter of the second

secondary vessel. After the first element has been put into place, the second element is then coupled to the first element by engaging one or more of its turns in the turns of the first element.

This equipment permits reinforcement of the bifurcation but appears unsuitable for
5 treating a vascular narrowing or an occlusive lesion, in view of its structure and of the low possibility of radial expansion of its two constituent elements.

Moreover, the shape of the first element does not correspond to the shape of a bifurcation, which has a widened transitional zone between the end of the principal vessel and the ends of the secondary vessels. Thus, this equipment does not make it possible to
10 fully support this wall or to treat a dissection in the area of this wall. Additionally, the separate positioning of these two elements is quite difficult.

Summary of the Invention

There is provided in accordance with one aspect of the present invention, a method of deploying first and second stents in the vicinity of a vascular bifurcation of a main vessel
15 into a first and a second branch vessels. The method comprises the steps of providing a delivery catheter having first and second stents thereon. The catheter is positioned such that the first and second stents are in the vicinity of the bifurcation. The first stent is deployed in a branch vessel, and the second stent is deployed in the main vessel. The second stent expands to a first diameter at a proximal end and a second, greater diameter at
20 a distal end.

In one implementation of the invention, the deploying step includes inflating a balloon within at least one of the stents. The deploying step may additionally or alternatively comprise the step of permitting at least one of the stents to self expand.

In accordance with another aspect of the present invention, there is provided a
25 deployment system for treating a bifurcation of a main vessel and a first and second branch vessels. The deployment system comprises an elongate flexible body, having a proximal end and a distal end, and a first stent and a second stent carried by the distal end. A restraint is provided for releasably restraining the stents on the flexible body. The first stent has different dimensions in an unconstrained expanded configuration than the second stent.

30 Preferably, a guidewire lumen extends axially through at least a portion of the flexible body. The guidewire lumen has a proximal access port and a distal access port. In one embodiment, the proximal access port is positioned along the flexible body, spaced

distally apart from the proximal end. Alternatively, the proximal access port is positioned at the proximal end of the flexible body.

In one embodiment, the releasable restraint comprises an axially moveable control element extending along the length of the flexible body. The control element may be
5 connected to a tubular sheath, which is axially moveably carried by the distal end of the flexible body. Alternatively, the releasable restraint may comprise a dissolvable media.

In one embodiment, only one of the first and second stents expands into a substantially cylindrical configuration in an unconstrained expansion.

In accordance with a further aspect of the present invention, there is provided a
10 method of treating a vascular bifurcation of a main vessel into first and second branch vessels. The method comprises the steps of deploying a substantially cylindrical stent in a first branch vessel, and deploying a tapered stent in the main vessel. Both the substantially cylindrical stent and the tapered stent are deployed from the same catheter. Preferably, at least one of the substantially cylindrical stent and the tapered stent is deployed from a
15 delivery catheter by axially displacing an outer sheath on the delivery catheter. In one embodiment, the tapered stent has a relatively smaller diameter first end and a relatively larger diameter second end, and the cylindrical stent is positioned adjacent the second end.

In accordance with another aspect of the present invention, there is provided a stent deployment catheter. The catheter comprises an elongate flexible tubular body, having a
20 proximal end and a distal end. A first and second stent are carried by the distal end. A handpiece is provided on the proximal end. A control is provided on the handpiece, having a first position for indicating partial deployment of the first stent, and a second position indicating complete deployment of the first stent. Preferably, the control further comprises a third position, indicating partial deployment of the second stent. The control preferably
25 also includes a fourth position, indicating complete deployment of the second stent.

In accordance with a further aspect of the present invention, there is provided a method of treating a bifurcation of a main vessel into first and second branch vessels. The method comprises the steps of providing a catheter, having a first and a second stent thereon. The catheter is positioned in the vicinity of the bifurcation, and a first stent is
30 partially deployed into the first branch vessel. Contrast media is introduced to permit visualization of the location of the first stent, and the first stent is thereafter completely deployed into the first branch. The method additionally comprises the step of partially

deploying the second stent in the main vessel. Contrast media may be introduced to permit visualization of the partially deployed second stent in the main vessel. The second stent may thereafter be completely deployed in the main vessel.

5 All of these embodiments are intended to be within the scope of the present invention herein disclosed. These and other embodiments of the present invention will become readily apparent to those skilled in the art from the following detailed description of the preferred embodiments having reference to the attached figures, the invention not being limited to any particular embodiment(s) disclosed.

Brief Description of the Drawings

10 Having thus summarized the general nature of the invention, certain preferred embodiments and modifications thereof will become apparent to those skilled in the art from the detailed description herein having reference to the attached figures, of which:

Figure 1 is a side view of a first embodiment of a stent system shown in an expanded state;

15 Figure 2 is a perspective, partial cutaway view of the stent system of Figure 1 shown in a state of radial contraction, as disposed on a delivery catheter;

Figure 3 is a longitudinal sectional view of a bifurcation treatable by the stent system of Figure 1;

20 Figure 4 is a section view of the bifurcation of Figure 3 showing a delivery catheter positioned therein;

Figure 5 is a section view of the bifurcation of Figure 3 showing an embodiment of a stent system shown in a partially contracted state on a portion of a delivery catheter;

Figure 6 is a section view of the bifurcation of Figure 3 showing an embodiment of a stent system shown in an expanded and fully deployed state;

25 Figure 7 is a section view of a bifurcation presenting an aneurysm and an embodiment of a stent system shown deployed therein,

Figure 8 is a side view of a stent system according to a second embodiment shown in an expanded state;

30 Figure 9 is a plan view of a delivery catheter usable to deploy a stent system having certain features and advantages;

Figure 9A is an alternative embodiment of a proximal handpiece of the delivery catheter of Figure 9;

Figure 9B is an alternative embodiment of the delivery catheter of Figure 9;

Figure 9C is a section view of a portion of the delivery catheter of Figure 9 taken through line 9C-9C and specifically showing an alternative pull wire lumen;

5 Figure 9D is a section view of a portion of the delivery catheter of Figure 9 taken through line 9D-9D and specifically showing a retaining band;

Figure 9E is a detail view of a retraction band retention assembly of the delivery catheter of Figure 9;

Figure 10 is a partial cutaway view of a distal portion of the catheter of Figure 9 including a stent system disposed thereon;

10 Figure 10A is an alternative embodiment of a distal end assembly of the delivery catheter of Figure 9B;

Figure 10B is a detail view of a distal portion of the outer sheath shown in Figure 10;

Figure 10C is a section view taken along the line 10C-10C of Figure 10;

15 Figure 11A is a plan view of a transitional portion of the catheter of Figure 9;

Figure 11B is a cross sectional view of the transitional portion taken along the line 11B-11B of Figure 11A;

Figure 11C is a transverse sectional view of the transitional portion taken along the line 11C-11C of Figure 11A;

20 Figure 11D is a cross sectional view of the proximal shaft taken along the line 11D-11D of Figure 11A;

Figure 12 is a side section view of a distal portion of an embodiment of a delivery catheter having certain features and advantages;

25 Figure 13 is a section view of a bifurcation showing an embodiment of a delivery catheter positioned therein;

Figure 14 is a section view of a bifurcation showing a first stent in a partially deployed state;

Figure 15 is a section view of a bifurcation showing a first stent in a fully deployed state;

30 Figure 16 is a section view of a bifurcation showing a second stent in a partially deployed state; and

Figure 17 is a section view of a bifurcation showing a second stent in a fully deployed state.

Figure 18 is a section view of a bifurcation as in Figure 17, with a second branch stent deployed in the second branch.

5

Detailed Description of the Preferred Embodiment

As described above, the attached Figures illustrate a stent system and corresponding delivery system for use in treating vessels (e.g. conduits) within the human body at areas of bifurcations. Figure 3 shows a bifurcation 30 in which a main conduit or vessel 32 separates into two secondary branch conduits or vessels 34. The stent system generally includes a pair of dissimilar stents specifically designed for use in an area of a bifurcation 30. Such dissimilar stents are then disposed on an elongate catheter for insertion into the human body. The dissimilar stents may be self-expanding or manually expandable such as by a balloon about which the stents may be disposed as will be described in further detail below.

15

Figure 1 shows one embodiment of an expandable stent system 10 permitting the treatment of bodily conduits in the area of a bifurcation such as that shown. The stent system 10, shown in an expanded state in Figure 1, generally comprises first 12 and second 14 stent portions which may each be divided into two segments, thus creating four successive segments 22, 24, 26, 28, of meshwork structure. The first stent 12 is generally adapted to be disposed in a branch conduit or vessel 34 of a bifurcation, while the second stent 14 is generally adapted to be disposed in a main vessel 32. If desired, the segments may be connected to one another via one or more bridges of material 18. The stents 12, 14 are generally movable between a contracted position and an expanded position. As will be clear to those skilled in the art, the stents may be self-expanding or balloon-expandable.

25

According to the illustrated embodiment, the stents 12, 14 generally comprise an expandable mesh structure which includes a plurality of mesh cells 36. The mesh cells 36 of these segments are in one embodiment elongated in the longitudinal direction of the stents 12, 14 and have in each case a substantially hexagonal shape in the embodiment shown. Those skilled in the art will recognize that the mesh used to form the stent segments 22, 24, 26, and 28 may comprise a variety of other shapes known to be suitable for use in stents. For example a suitable stent may comprise mesh with repeating quadrilateral shapes, octagonal shapes, a series of curvatures, or any variety of shapes such

30

that the stent is expandable to substantially hold a vessel or conduit at an enlarged inner diameter.

The first stent **12** may be divided into two segments **22** and **24** which may be identical to each other and typically have a tubular shape with a diameter which is substantially greater than the diameter of one of the secondary branch conduits **34**. Those skilled in the art will recognize that the first stent may comprise a variety of shapes such that it functions as described herein. The first stent **12** may be expandable to a substantially cylindrical shape having a constant diameter along its length. The first stent **12** may comprise a range of lengths depending on the specific desired location of placement. For example, the length of the first stent **12** will typically be between about 1 and about 4 centimeters as desired.

The second stent **14** is preferably adapted to be deployed in close proximity to the first stent **12**, and may also be divided into upper **26** and lower **28** segments. The lower segment **28** of the second stent **14** typically has a tubular cross-sectional shape and has an expanded diameter which is substantially greater than the diameter of the principal conduit **32** (Figure 3). The upper segment **26** of the second stent **14** preferably comprises a larger diameter at its distal (upper) end **38** than at its proximal (lower) end **40**. In one embodiment the upper segment of the second stent portion comprises a substantially conical shape. In an alternative embodiment, the second stent **14** may be tapered radially outward along its entire length in the distal direction. In either embodiment however, the expanded diameter of the distal end **38** of the second stent **14** is preferably substantially larger than the expanded diameter of the proximal end **42** of the first stent **12**. For example, the distal end **38** of the second stent **14** may expand to a diameter that is at least about 105%, and preferably at least about 110%, and in some embodiments as much as 120% or more, of the diameter of the proximal end **42** of the first stent **12**. The second stent **14** may comprise a range of lengths depending on the specific desired location of placement. For example, the second stent **14** will typically be between 1 and 4 centimeters as desired.

In its expanded state, as shown in Figure 1, the upper segment **26** of the second stent **14** typically has mesh cells **36** whose width increases progressively, compared to that of the meshes of the lower segment **28**, on the one hand in the longitudinal sense of the dual stent device **10**, in the direction of the distal end **38** of the second stent **14**, and, on the other hand, in the transverse sense of the second stent **14**, in the direction of a generatrix

diametrically opposite that located in the continuation of the bridge 18. Alternatively stated, the upper segment 26 of the second stent 14 preferably comprises a mesh with multiple cellular shapes 36 which may have larger dimensions at a distal end 38 of the stent 14 than those at the proximal end 40 such that the second stent 14 expands to a substantially funnel shape.

In the embodiment shown, this increase in the width of the mesh cells 36 results from an increase in the length of the edges 48 of the mesh cells 36 disposed longitudinally, as well as an increase in the angle formed between two facing edges 48.

This segment 26 thus may have a truncated shape with an axis which is oblique in relation to the longitudinal axis of the first stent 12 when expanded. This shape, for example, corresponds to the shape of the bifurcation shown in the area of the widened transitional zone 46 (Figure 3) which separates the end of the principal conduit 32 from the ends of the secondary conduits 34. In a preferred embodiment, the second stent 14 is placed in close proximity to the first stent 12. For example, the distal end 38 of the second stent 14 is preferably placed within a distance of about 4 mm of the distal end 42 of the first stent 12, more preferably this distance is less than about 2 mm, and most preferably the stents are placed within 1 mm of one another.

In the embodiment shown in Figure 1, the distance between first and second stents 12, 14 is held substantially fixed by the provision of a bridge 18 between them. Bridges 18 may be provided to join the first and second stents 12, 14 to one another and/or to join the upper and lower segments 22, 24 and 26, 28 of each stent 12 and 14 together. If present, the bridges 18 may connect the adjacent ends of the segments 22, 24 and 26, 28 and typically have a small width, so that they can undergo a certain flexion, making it possible to orient these segments in relation to one another, in particular the lower segment 24 of the first stent 12 in relation to the upper segment 26 of the second stent 14.

In addition, in other embodiments, the bridges 18 could be integral with one of the connected segments and separately connected, such as by welding, to the other connected segment. For example, the bridge 18 which connects the first and second stents 12, 14 could be integral with the upper segment 26 of the second stent 14 and connected to lower segment 24 of the first segment 26. Alternatively, the bridge 18 could be integral with the lower segment 24 of the first stent 12 and connected to the upper segment 26 of the second stent 14.

In yet other embodiments, bridges 18 could be separate pieces of materials which are separately connected to segments 22, 24, 26, 28 such as by welding, adhesion, or other bonding method. In all of these embodiments, the first stent 12 can be made from different pieces of material than the second stent 14. A tube from which the first stent 12 may be made (e.g. by laser cutting techniques) may comprise a smaller diameter than a tube from which the second stent 14 may be made. The respective tubes may or may not be made of the same material. Alternatively, the first and second stent may be formed from a single piece of material.

When the segments 26 and 28 of the second stent 14 are made from tubes of a smaller diameter than the segments 22 and 24 of the first stent 12, the radial force of the first stent segments 22 and 24 is larger than the radial force of the second stent segments 26 and 28, especially at larger cross sections.

Accordingly, bridges 18 can be made from one of these tubes, and thus be integral with segments 22 and 24 or segments 26 and 28. Alternatively, the bridges 18 can be separate pieces of material.

In further embodiments, bridges 18 are omitted such that the individual segments are spaced as desired during installation and use. These individual segments are still delivered and implanted in the same core and sheath assembly.

The bridges 18 between two consecutive segments could be greater or smaller in number than six, and they could have a shape other than an omega shape, permitting their multidirectional elasticity, and in particular a V shape or W shape.

For example, Figure 8 shows an alternative embodiment of the stent system 10 with first 12 and second 14 stents shown in their unconstrained, expanded states. According to this embodiment, each stent 12, 14 may be divided into two segments 22, 24 and 26, 28 and may include one or more flexible bridges 18 connecting the first 12 and second stents 14 to one another. In this embodiment, the two consecutive segments 22, 24 and 26, 28 of the first and second stents 12 and 14, are connected by a plurality (e.g. six) omega-shaped bridges 50. The curved central part 52 of these bridges 50 may have a multidirectional elasticity permitting the appropriate longitudinal orientation of the various segments in relation to one another. The advantage of these bridges 50 is that they provide the stent with longitudinal continuity, which facilitates the passage of the stent system into a highly

curved zone and which eliminates the need to reduce this curvature, (which may be dangerous in the cases of arteriosclerosis).

Thus, the stent system **10** of Figure 8 can comprise several segments **22, 24, 26, 28** placed one after the other, in order to ensure supplementary support and, if need be, to increase the hold of the stents in the bifurcation **30**. The upper segment **26** of the second stent **14** could have an axis coincident with the longitudinal axis of the first stent, and not oblique in relation to this axis, if such is rendered necessary by the anatomy of the bifurcation which is to be treated.

Alternatively, the lower segment **24** of the first stent **12** could itself have, in the expanded state, a widened shape similar to that of the second stent and corresponding to the shape of the widened connecting zone (increasing diameter in the proximal direction) by which, in certain bifurcations, the secondary conduits **34** are connected to the widened transition zone **46**. Thus, the lower segment **24** of the first stent **12**, or the entire first stent **12** may have a first diameter at its distal end, and a second, larger diameter at its proximal end with a linear or progressive curve (flared) taper in between. According to this embodiment, this segment **24** would thus have a shape corresponding to the shape of this widened connecting zone, and would ensure perfect support thereof.

One method of making a self-expanding stent is by appropriate cutting of a sheet of nickel/titanium alloy (for example, an alloy known by the name NITINOL may appropriately be used) into a basic shape, then rolling the resulting blank into a tubular form. The blank may be held in a cylindrical or frustroconical form by welding the opposing edges of this blank which come into proximity with each other. The stent(s) may also be formed by laser cutting from metal tube stock as is known in the art. Alternatively, a stent may be formed by selectively bending and forming a suitable cylindrical or noncylindrical tubular shape from a single or multiple wires, or thin strip of a suitable elastic material. Those skilled in the art will understand that many methods and materials are available for forming stents, only some of which are described herein.

Some Nickel Titanium alloys are malleable at a temperature of the order of 10 °C but can recover a neutral shape at a temperature substantially corresponding to that of the human body. Figure 2 shows the stent system **10** disposed on a delivery catheter in a state of radial contraction. In one embodiment, a self-expanding stent may be contracted by cooling its constituent material of nickel-titanium or other shape-memory alloy to a

temperature below its transformation temperature. The stent may later be expanded by exposing it to a temperature above the transformation temperature. In the present use, a shape-memory alloy with a transformation temperature at or below normal body temperature may be used. Those skilled in the art will recognize that a self-expanding stent
5 made of a substantially elastic material may also be mechanically contracted from its expanded shape by applying a radial compressive force. The stent may then be allowed to expand under the influence of the material's own elasticity. Nickel titanium and other alloys such as such as Silver-Cadmium (Ag-Cd), Gold-Cadmium (Au-Cd) and Iron-Platinum (Fe₃-Pt), to name but a few offer desirable superelastic qualities within a specific
10 temperature range.

In one embodiment, the contraction of a stent may cause the mesh cell edges **48** to pivot in relation to the transverse edges **49** of the mesh cells **36** in such a way that the mesh cells **36** have, in this state of contraction, a substantially rectangular shape. Those skilled in the art will recognize that other materials and methods of manufacturing may be employed
15 to create a suitable self-expanding stent.

Alternatively, the stents used may be manually expandable by use of an inflatable dilatation balloon with or without perfusion as will be discussed further below. Many methods of making balloon-expandable stents are known to those skilled in the art. Balloon expandable stents may be made of a variety of bio-compatible materials having
20 desirable mechanical properties such as stainless steel and titanium alloys. Balloon-expandable stents preferably have sufficient radial stiffness in their expanded state that they will hold the vessel wall at the desired diameter. In the case of a balloon-expandable second stent **14**, the balloon on which the second stent **14** is disposed may be specifically adapted to conform to the desired shape of the second stent **14**. Specifically, such a balloon
25 will preferably have a larger diameter at a distal end than at a proximal end.

The present discussion thus provides a pair of dissimilar stents permitting the treatment of a pathological condition in the area of a bifurcation **30**. This system has the many advantages indicated above, in particular those of ensuring a perfect support of the vessel wall and of being relatively simple to position.

30 For the sake of simplification, the segment which has, in the unconstrained expanded state, a cross section substantially greater than the cross section of one of the secondary conduits will be referred to hereinafter as the "secondary segment", while the

segment which has, in the expanded state, a truncated shape will be referred to hereinafter as the "truncated segment."

The secondary segment is intended to be introduced into the secondary conduit in the contracted state and when expanded will preferably bear against the wall of the conduit.
5 This expansion not only makes it possible to treat a narrowing or a dissection situated in the area of the conduit, but also to ensure perfect immobilization of the apparatus in the conduit.

In this position, the truncated segment bears against the wall of the conduit delimiting the widened transitional zone of the bifurcation, which it is able to support fully.
10 A narrowing or a dissection occurring at this site can thus be treated by means of this apparatus, with uniform support of the vascular wall, and thus without risk of this wall being damaged.

The two segments may be adapted to orient themselves suitably in relation to each other upon their expansion.

Advantageously, at least the truncated segment may be covered by a membrane (for
15 example, Dacron® or ePTFE) which gives it impermeability in a radial direction. This membrane makes it possible to trap between it and the wall of the conduit, the particles which may originate from the lesion being treated, such as arteriosclerotic particles or cellular agglomerates, thus avoiding the migration of these particles in the body. Thus, the
20 apparatus can additionally permit treatment of an aneurysm by guiding the liquid through the bifurcation and thereby preventing stressing of the wall forming the aneurysm.

The segments can be made from tubes of material of a different diameter, as discussed above, with the tube for the truncated segment having a larger diameter than the tube for the secondary segment. The tubes may be made from the same material. The use
25 of tubes of different diameters can result in the truncated segment having a larger radial force, especially at larger diameters.

The apparatus can comprise several secondary segments, placed one after the other, to ensure supplementary support of the wall of the secondary conduit and, if need be, to increase the anchoring force of the stent in the bifurcation. To this same end, the apparatus
30 can comprise, on that side of the truncated segment directed toward the principal conduit, at least one radially expandable segment having, in the expanded state, a cross section which is substantially greater than the cross section of the principal conduit.

These various supplementary segments may or may not be connected to each other and to the two aforementioned segments by means of flexible links, such as those indicated above.

5 The flexible links can be integral with one of the segments and separately connected to the other segment, or the flexible links can be separate pieces of material separately connected to both segments, such as by welding.

10 Preferably, the flexible link between two consecutive segments is made up of one or more bridges of material connecting the two adjacent ends of these two segments. Said bridge or bridges are advantageously made of the same material as that forming the segments.

Each segment may have a meshwork structure, the meshes being elongated in the longitudinal direction of the stent, and each one having a substantially hexagonal shape; the meshes of the truncated segment may have a width which increases progressively in the longitudinal sense of the stent, in the direction of the end of this segment having the
15 greatest cross section in the expanded state.

This increase in the width of the meshes is the result of an increase in the length of the edges of the meshes disposed longitudinally and/or an increase in the angle formed between two facing edges of the same mesh.

20 In addition, the truncated segment can have an axis not coincident with the longitudinal axis of the secondary segment, but oblique in relation to this axis, in order to be adapted optimally to the anatomy of the bifurcation which is to be treated. In this case, the widths of the meshes of the truncated segment also increase progressively, in the transverse sense of the stent, in the direction of a generatrix diametrically opposite that located in the continuation of the bridge connecting this segment to the adjacent segment.

25 The apparatus can be made of a metal with shape memory, which becomes malleable, without elasticity, at a temperature markedly lower than that of the human body, in order to permit retraction of the apparatus upon itself, and to allow it to recover its neutral shape at a temperature substantially corresponding to that of the human body. This metal may be a nickel/titanium alloy known by the name NITINOL.

30 The deployment catheter for positioning the stent or stents comprises means for positioning the stents and means for permitting the expansion of the stents when the latter are in place. These means can comprise a catheter having a removable sheath in which the

stent is placed in the contracted state, when this stent is made of an elastic material, or a support core comprising an inflatable balloon on which the stent is placed, when this stent is made of a nonelastic material.

5 In either case, this equipment comprises, according to the invention, means with which it is possible to identify and access, through the body of the patient, the longitudinal location of the truncated segment, so that the latter can be correctly positioned in the area of the widened zone of the bifurcation.

10 In the case where the expansion of this same segment is not uniform in relation to the axis of the stent, the equipment additionally comprises means with which it is possible to identify, through the body of the patient, the angular orientation of the stent in relation to the bifurcation to be treated, so that the part of this segment having the greatest expansion can be placed in a suitable manner in relation to the bifurcation.

15 Referring to FIG. 9, the stent system is generally deployed using an elongate flexible stent deployment catheter 100. Although primarily described in the context of a multiple stent placement catheter without additional functional capabilities, the stent deployment catheter described herein can readily be modified to incorporate additional features such as an angioplasty balloon or balloons, with or without perfusion conduits, radiation or drug delivery capabilities, or stent sizing features, or any combination of these features, as will be readily apparent to one of skill in the art in view of the disclosure herein.

20 The elongate delivery catheter 100 generally includes a proximal end assembly 102, a proximal shaft section 110 including a tubular body 111, a distal shaft section 120 including a distal tubular body 113, and a distal end assembly 107. The proximal end 102 may include a handpiece 140, having one or more hemostatic valves and/or access ports 106, such as for the infusion of drugs, contrast media or inflation media in a balloon expandable stent embodiment, as will be understood by those of skill in the art. In addition, 25 a proximal guidewire port 172 may be provided on the handpiece 140 in an over the wire embodiment (see Figure 9A). The handpiece 140 disposed at the proximal end of the catheter 100 may also be adapted to control deployment of the stents disposed on the catheter distal end 104 as will be discussed.

30 The length of the catheter depends upon the desired application. For example, lengths in the area of about 120 cm to about 140 cm are typical for use in coronary applications reached from a femoral artery access. Intracranial or lower carotid artery

applications may call for a different catheter shaft length depending upon the vascular access site, as will be apparent to those of skill in the art.

The catheter **100** preferably has as small an outside diameter as possible to minimize the overall outside diameter (e.g. crossing profile) of the delivery catheter, while at the same time providing sufficient column strength to permit distal transluminal advancement of the tapered tip **122**. The catheter **100** also preferably has sufficient column strength to allow an outer, axially moveable sheath **114** to be proximally retracted relative to the central core **112** in order to expose the stents **118**. The delivery catheter **100** may be provided in either "over-the-wire" or "rapid exchange" types as will be discussed further below, and as will generally be understood by those skilled in the art.

In a catheter intended for peripheral vascular applications, the outer sheath **114** will typically have an outside diameter within the range of from about 0.065 inches to about 0.092 inches. In coronary vascular applications, the outer sheath **114** may have an outside diameter with the range of from about 0.039 inches to about 0.065. Diameters outside of the preferred ranges may also be used, provided that the functional consequences of the diameter are acceptable for the intended purpose of the catheter. For example, the lower limit of the diameter for any portion of catheter **100** in a given application will be a function of the number of guidewire, pullwire or other functional lumen contained in the catheter, together with the acceptable minimum flow rate of dilatation fluid, contrast media or drugs to be delivered through the catheter and minimum contracted stent diameter.

The ability of the catheter **100** to transmit torque may also be desirable, such as to avoid kinking upon rotation, to assist in steering, and in embodiments having an asymmetrical distal end on the proximal stent **14**. The catheter **100** may be provided with any of a variety of torque and/or column strength enhancing structures, for example, axially extending stiffening wires, spiral wrapped support layers, or braided or woven reinforcement filaments which may be built into or layered on the catheter **100**. See, for example, U.S. Pat. No. 5,891,114 to Chien, et al..

Referring to FIG. **11D**, there is illustrated a cross-sectional view through the proximal section **106** of the catheter shaft **100** of FIG. **9**. The embodiment shown in Figure **11D** represents a rapid exchange embodiment, and may comprise a single or multiple lumen extrusion or a hypotube including a pull wire lumen **220**. In an over-the-wire embodiment, the proximal section **106** additionally comprises a proximal extension of a

guidewire lumen 132 and a pull wire lumen 220. The proximal tube 111 may also comprise an inflation lumen in a balloon catheter embodiment as will be understood by those skilled in the art.

At the distal end 107, the catheter is adapted to retain and deploy one or more stents
5 within a conduit of a human body. With reference to Figures 10A and 12, the distal end assembly 107 of the delivery catheter 100 generally comprises an inner core 112, an axially moveable outer sheath 114, and optionally one or more inflatable balloons 116 (Fig. 12). The inner core 112 is preferably a thin-walled tube at least partially designed to track over a
10 extends along at least a distal portion 120 of the central core 112 on which the stents 118 are preferably disposed.

The outer sheath 114 may extend over a substantial length of the catheter 100, or may comprise a relatively short length, distal to the proximal guidewire access port 172 as will be discussed. In general, the outer sheath 114 is between about 5 and about 25 cm
15 long.

Referring to Figure 10, the illustrated outer sheath 114 comprises a proximal section 115, a distal section 117 and a transition 119. The proximal section 115 has an inside diameter which is slightly greater than the outside diameter of the tubular body 113. This enables the proximal section 115 to be slideably carried by the tubular body 113. Although
20 the outer sheath 114 may be constructed having a uniform outside diameter throughout its length, the illustrated outer sheath 114 steps up in diameter at a transition 119. The inside diameter of the distal section 117 of outer sheath 114 is dimensioned to slideably capture the one or more stents as described elsewhere herein. In a stepped diameter embodiment such as that illustrated in Figure 10, the axial length of the distal section 117 from the
25 transition 119 to the distal end is preferably sufficient to cover the stent or stents carried by the catheter 100. Thus, the distal section 117 in a two stent embodiment is generally at least about 3 cm and often within the range of from about 5 cm to about 10 cm in length. The axial length of the proximal section 115 can be varied considerably, depending upon the desired performance characteristics. For example, proximal section 115 may be as short
30 as one or two centimeters, or up to as long as the entire length of the catheter. In the illustrated embodiment, the proximal section 115 is generally within the range of from about 5 cm to about 15 cm long.

The outer sheath **114** and inner core **112** may be produced in accordance with any of a variety of known techniques for manufacturing rapid exchange or over the wire catheter bodies, such as by extrusion of appropriate biocompatible polymeric materials. Known materials for this application include high and medium density polyethylenes, polytetrafluoroethylene, nylons, PEBAX, PEEK, and a variety of others such as those disclosed in U.S. Pat. No. 5,499,973 to Saab. Alternatively, at least a proximal portion or all of the length of central core **112** and/or outer sheath **114** may comprise a metal or polymeric spring coil, solid walled hypodermic needle tubing, or braided reinforced wall, as is understood in the catheter and guidewire arts.

The distal portion **117** of outer sheath **114** is positioned concentrically over the stents **118** in order to hold them in their contracted state. As such, the distal portion **117** of the outer sheath **114** is one form of a releasable restraint. The releasable restraint preferably comprises sufficient radial strength that it can resist deformation under the radial outward bias of a self-expanding stent. The distal portion **117** of the outer sheath **114** may comprise a variety of structures, including a spring coil, solid walled hypodermic needle tubing, banded, or braided reinforced wall to add radial strength as well as column strength to that portion of the outer sheath **114**. Alternatively, the releasable restraint may comprise other elements such as water soluble adhesives or other materials such that once the stents are exposed to the fluid environment and/or the temperature of the blood stream, the restraint material will dissolve, thus releasing the self-expandable stents. A wide variety of biomaterials which are absorbable in an aqueous environment over different time intervals are known including a variety of compounds in the polyglycolic acid family, as will be understood by those of skill in the art. In yet another embodiment, a releasable restraint may comprise a plurality of longitudinal axial members disposed about the circumference of the stents. According to this embodiment anywhere from one to ten or more axial members may be used to provide a releasable restraint. The axial members may comprise cylindrical rods, flat or curved bars, or any other shape determined to be suitable.

In some situations, self expanding stents will tend to embed themselves in the inner wall of the outer sheath **114** over time. As illustrated in Figures **9D** and **10A**, a plurality of expansion limiting bands **121** may be provided to surround sections of the stents **12**, **14** in order to prevent the stents from becoming embedded in the material of the sheath **114**. The bands **121** may be provided in any of a variety of numbers or positions depending upon the

stent design. Figure 10A illustrates the bands positioned at midpoints of each of the four proximal stent sections 127 and each of the five distal stent sections. In an alternative embodiment, the bands 121 are positioned over the ends of adjacent stent sections. The bands 121 may be made of stainless steel, or any other suitable metal or relatively non-compliant polymer. Of course, many other structures may also be employed to prevent the self-expanding stents from embedding themselves in the plastic sheath. Such alternative structures may include a flexible coil, a braided tube, a solid-walled tube, or other restraint structures which will be apparent to those skilled in the art in view of the disclosure herein.

The inner surface of the outer sheath 114, and/or the outer surface of the central core 112 may be further provided with a lubricious coating or lining such as Paralene, Teflon, silicone, polyimide-polytetrafluoroethylene composite materials or others known in the art and suitable depending upon the material of the outer sheath 114 and/or central core 112.

As illustrated in Figure 10B, at least a distal portion of sheath 114 may comprise a two layer construction having an outer tube 210 and an inner tube or coating 212. The exterior surface of the outer tube 210 is preferably adapted to slide easily within the vessels to be treated, while the inner surface is generally adapted to have a low coefficient of static friction with respect to the stents, thus allowing the sheath to slide smoothly over the stents. The outer tube 210 may, for example, be made of or coated with HDPE or PEBAX, and the inner tube 212 may, for example, be made of or coated with HDPE, PTFE, or FEP. In an embodiment in which the inner tube is made with a PTFE liner, however, the distal end 214 of the lubricious inner layer or tube 212 is preferably spaced proximally from the distal end 216 of the outer tube 210 by a distance within the range of from about 1 mm to about 3 mm. This helps prevent the stent from prematurely jumping distally out of the sheath during deployment due to the high lubricity of the PTFE surface.

Figure 10 illustrates one embodiment of a sheath retraction system. The system illustrated generally includes a sheath pull wire 222, a pull wire slot 224, a sheath retraction band 226, and an outer sheath 114. The sheath retraction band 226 may be a tubular element thermally or adhesively bonded or otherwise secured to a portion of the outer sheath 114. In the illustrated embodiment, the retraction band 226 comprises a section of stainless steel tubing having an outside diameter of about 0.055 inches, a wall thickness of about 0.0015 inches and an axial length of 0.060 inches. However, other dimensions may be readily utilized while still accomplishing the intended function. The sheath retraction

band **226** is positioned within the distal portion **117** of the outer sheath **114**, just distally of the diameter transition **119**. The retraction band **226** may be connected to the interior surface of the outer sheath **114** by heat fusing a pair of bands **225** to the inside surface of the outer sheath at each end of the retraction band (see Figure **9E**). Alternatively, the retraction band **226** can be attached to the outer sheath by using adhesives, epoxies, or by mechanical methods such as crimping and swaging or a combination of these. In this manner, the pull force which would be required to proximally dislodge the retraction band **226** from the outer sheath **114** is greatly in excess of the proximal traction which will be applied to the pull wire **222** in clinical use. The distal end of the pull wire **222** is preferably welded, soldered, bonded, or otherwise secured to the sheath retraction band **226**. The pull wire **222** may alternatively be bonded directly to the outer sheath.

The pull wire slot **224** is preferably of sufficient length to allow the sheath **114** to be fully retracted. Thus, the pull wire slot **224** is preferably at least as long as the distance from the distal end of the stent stop **218** to the distal end of the sheath **114** as shown in Figure **10A**. Slot lengths within the range of from about 1 cm to about 10 cm are presently contemplated for a two stent deployment system. With the sheath **114** in the distal position as shown, the pull wire slot **224** is preferably entirely covered by the proximal portion **115** of the sheath **114**. Alternatively, in an embodiment in which the proximal extension of sheath **114** extends the entire length of the catheter **100**, discussed above, it can be directly attached to the control **150**, in which case a pull wire **222** and slot **224** as shown might not be used.

In yet another embodiment illustrated for example in Figures **9B** and **9C**, a pull wire lumen **220** may terminate sufficiently proximally from the retraction band **226** that a slot as shown may not be used.

The pull wire **222** may comprise a variety of suitable profiles known to those skilled in the art, such as round, flat straight, or tapered. The diameter of a straight round pull wire **222** may be between about 0.008" and about 0.018" and in one embodiment is about 0.009". In another embodiment, the pull wire **222** has a multiple tapered profile with diameters of 0.015", 0.012", and 0.009" and a distal flat profile of 0.006" x 0.012". The pull wire **222** may be made from any of a variety of suitable materials known to those skilled in the art, such as stainless steel or nitinol, and may be braided or single strand and may be coated with a variety of suitable materials such as Teflon, Paralene, etc. The wire

222 has sufficient tensile strength to allow the sheath 114 to be retracted proximally relative to the core 112. In some embodiments, the wire 222 may have sufficient column strength to allow the sheath 114 to be advanced distally relative to the core 112 and stents 12, 14. For example, if the distal stent 12 has been partially deployed, and the clinician determines that the stent 12 should be re-positioned, the sheath 114 may be advanced distally relative to the stent 12 thereby re-contracting and capturing that stent on the core.

In general, the tensile strength or compressibility of the pull wire 222 may also be varied depending upon the desired mode of action of the outer sheath 114. For example, as an alternative to the embodiment described above, the outer sheath 114 may be distally advanced by axially distally advancing the pull wire 222, to release the stent 118. In a hybrid embodiment, the outer sheath 114 is split into a proximal portion and a distal portion. A pull wire is connected to the proximal portion, to allow proximal retraction to release the proximal stent. A push wire is attached to the distal portion, to allow distal advance, thereby releasing the distal stent. These construction details of the catheter 100 and nature of the wire 222 may be varied to suit the needs of each of these embodiments, as will be apparent to those skilled in the art in view of the disclosure herein.

The stents 118 are carried on the central support core 112, and are contracted radially thereon. By virtue of this contraction, the stents 118 have a cross section which is smaller than that of the conduits 32 and 34, and they can be introduced into these as will be described below. The stents 118 are preferably disposed on a radially inwardly recessed distal portion 113 of the central core 112 having a smaller diameter than the adjacent portions of the core 112. This recess 113 is preferably adjacent a distal abutment such as a shoulder 124 which may be in the form of a proximally facing surface on a distal tip 122. Distal tip 122 has an outer diameter smaller than that of the stents 118 when the stents are expanded, but greater than the diameter of the stents 118 when they are contracted. This abutment 124 consequently prevents distal advancement of the stents 118 from the core 112 when the stents 118 are contracted.

Proximal movement of the stents 118 relative to the core 112 is prevented when the stents are in the radially contracted configuration by a proximal abutment surface such as annular shoulder 125. The distal abutment 124 and proximal abutment 125 may be in the form of annular end faces formed by the annular recess 113 in the core 112, for receiving the compressed stents 118. See Figure 12. In one embodiment, illustrated in Figure 10A,

the proximal abutment **125** is carried by a stent stop **218**. Stent stop **218** may be integral with or attached to the central core **112**, and has an outside diameter such that it is in sliding contact with the inside surface of outer sheath **114**. The compressed stent **14** will thus not fit between the stop **218** and the outer sheath **114**.

5 The deployment device **100** typically has a soft tapered tip **122** secured to the distal end of inner core **112**, and usually has a guidewire exit port **126** as is known in the art. The tapered distal tip **122** facilitates insertion and atraumatic navigation of the vasculature for positioning the stent system **118** in the area of the bifurcation to be treated. The distal tip **122** can be made from any of a variety of polymeric materials well known in the medical
10 device arts, such as polyethylene, nylon, PTFE, and PEBAX. In the embodiment shown in Figure **10**, the distal tip **122** comprises an annular recess **230** sized and adapted to allow a distal portion of the outer sheath **114** to reside therein such that the transition between the tip and the outer sheath comprises a smooth exterior surface.

The distal tip **122** tapers in one embodiment from an outside diameter which is
15 substantially the same as the outer diameter of the outer sheath **114** at the proximal end **128** of the tip **122** to an outside diameter at its distal end **130** of slightly larger than the outside diameter of a guidewire. The overall length of the distal tip **122** in one embodiment of the delivery catheter **100** is about 3 mm to about 12 mm, and in one embodiment the distal tip is about 8 mm long. The length and rate of taper of the distal tip **122** can be varied
20 depending upon the desired trackability and flexibility characteristics. The tip **122** may taper in a linear, curved or any other manner known to be suitable.

With reference to Figures **11B** and **12**, a distal portion of the central core **112** preferably has a longitudinal axial lumen **132** permitting slideable engagement of the core
25 **112** on a guidewire **170**. The guidewire lumen **132** preferably includes a proximal access port **172** and a distal access port **126** through which the guidewire may extend. The proximal access port **172** may be located at a point along the length of the catheter **100**, as shown in Figures **11A** and **11B**, and discussed below (rapid exchange), or the proximal access port **172** may be located at the proximal end **102** of the catheter **100** (over the wire). In a rapid exchange embodiment, the proximal access port **172** is generally within about 25
30 cm of the distal access port **126**, and preferably is between about 20 cm and about 30 cm of the distal access port **126**. The guidewire lumen **132** may be non-concentric with the catheter centerline for a substantial portion of the length of the guidewire lumen **132**.

Figures 11A and 11B illustrate a transition between a proximal shaft tube 111 and a distal shaft tube 113 including a proximal guidewire access port 172 and a guidewire lumen 132. The guidewire lumen 132 may extend through a coextrusion, or may be a separate section of tubing which may be bonded, bound by a shrink wrap tubing, or otherwise held
5 relative to the proximal shaft tube 111.

In the construction shown in cross-section in Figure 11B, a proximal shaft tube 111 having a pull wire lumen 220 is joined to a distal shaft tube 113 having a continuation of pull wire lumen 220 as well as a guidewire lumen 132. In the illustrated embodiment, the proximal shaft tube 111 extends distally into the proximal end of connector tubing 230. A
10 mandrel is positioned within each lumen, and shrink tubing 236 is heated to bond the joint. An opening is subsequently formed in the shrink wrap to produce proximal access port 172 which provides access to the guidewire lumen 132.

In one embodiment, the proximal shaft tube 111 comprises a stainless steel hypodermic needle tubing having an outside diameter of about 0.025" and a wall thickness
15 of about 0.003". The distal end 123 of the hypotube is cut or ground into a tapered configuration. The axial length of the tapered zone may be varied widely, depending upon the desired flexibility characteristics of the catheter 100. In general, the axial length of the taper is within the range of from about 1 cm to about 5 cm, and, in one embodiment, is about 2.5 cm. Tapering the distal end of the hypotube at the transition with the distal
20 portion of the catheter provides a smooth transition of the flexibility characteristics along the length of the catheter, from a relatively less flexible proximal section to a relatively more flexible distal section as will be understood by those of skill in the art.

Referring to Figure 12, a guidewire 170 is illustrated as positioned within the guidewire lumen 132. As can be appreciated by those of skill in the art, the diameter of the
25 guidewire 170 is illustrated as slightly smaller (e.g., by about 0.001-0.003 inches) than the inside diameter of the guidewire lumen 132. Avoiding a tight fit between the guidewire 170 and inside diameter of guidewire lumen 132 enhances the slideability of the catheter over the guidewire 170. In ultra small diameter catheter designs, it may be desirable to coat the outside surface of the guidewire 170 and/or the inside walls of the guidewire lumen 132
30 with a lubricous coating to minimize friction as the catheter 100 is axially moved with respect to the guidewire 170. A variety of coatings may be utilized, such as Paralene,

Teflon, silicone, polyimide-polytetrafluoroethylene composite materials or others known in the art and suitable depending upon the material of the guidewire **170** or central core **112**.

As shown in Figure **12**, an inflation lumen **134** may also extend throughout the length of the catheter **100** to place a proximal inflation port in fluid communication with
5 one or more inflatable balloons **116** carried by the distal end of the catheter.

The inflatable balloon **116**, if present, may be positioned beneath one or both stents, such as stent **14** as illustrated in Figure **12** or proximally or distally of the stent, depending upon the desired clinical protocol. In one embodiment, as illustrated in Figure **12**, the stent may be a self expandable stent which is initially released by proximal retraction by the
10 outer sheath **114** as has been discussed. The balloon **16** is thereafter positioned in concentricity within the stent, such that it may be inflated without repositioning the catheter to enlarge and/or shape the stent. Post stent deployment dilatation may be desirable either to properly size and or shape the stent, or to compress material trapped behind the stent to increase the luminal diameter (e.g. angioplasty). In an alternate mode of
15 practicing the invention, angioplasty is accomplished prior to deployment of the stent either by a balloon on the stent deployment catheter **100** or by a separate angioplasty balloon catheter (or rotational atherectomy, laser or other recanalization device). The stent deployment catheter **100** is thereafter positioned within the dilated lesion, and the stent is thereafter deployed. Thus, balloon dilatation can be accomplished using either the
20 deployment catheter **100** or separate procedural catheter, and may be accomplished either prior to, simultaneously with, or following deployment of one or more stents at the treatment site.

As seen in Figure **9** and **9B**, the catheter also includes a handpiece **140** at the proximal end of the catheter **100**. The handpiece **140** is adapted to be engaged by the
25 clinician to navigate and deploy the stent system **118** as will be described below. The handpiece **140** preferably includes a control **150** adapted to control and indicate a degree of deployment of one or both stents. The control **150** is typically in mechanical communication with the sheath **114** such that proximal retraction of the control **150** results in proximal retraction of the sheath **114**. Those skilled in the art will recognize that distal
30 motion, rotational movement of a rotatable wheel, or other motion of various controls **150** may alternatively be employed to axially move such as distally advance or proximally retract the sheath **114** to expose the stents.

The illustrated control **150** is preferably moveable from a first position to a second position for partial deployment of the first stent **12**, and a third position for complete deployment of the first stent **12**. A fourth and a fifth positions are also provided to accomplish partial and complete deployment of the second stent **14**. The control **150** may include indicia **160** adapted to indicate the amount of each stent **12** or **14** which has been exposed as the sheath **114** is retracted relative to the core **112**. The indicia **160** may include dents, notches, or other markings to visually indicate the deployment progress. The control **150** may also or alternatively provide audible and/or tactile feedback using any of a variety of notches or other temporary catches to cause the slider to “click” into positions corresponding to partial and full deployment of the stents **12**, **14**. Alignable points of electrical contact may also be used. Those skilled in the art will recognize that many methods and structures are available for providing a control **150** as desired.

The catheter **100** may include a plurality of radiopaque markers **250** (seen best in **Figures 2, 10, and 10A**) impressed on or otherwise bonded to it, containing a radiopaque compound as will be recognized by those skilled in the art. Suitable markers can be produced from a variety of materials, including platinum, gold, barium compounds, and tungsten/rhenium alloy. Some of the markers **250A** may have an annular shape and may extend around the entire periphery of the sheath **114**. The annular markers **250A** may be situated, in the area of the distal end of the first stent **12**, the distal end of the second stent **14**, and in the area of the bridge **18** (**FIG. 1**) or space separating the stents **12**, **14**. A fourth marker **252** may be situated at substantially the halfway point of the generatrix of the lower segment of the second stent **14** situated in the continuation of the bridge **18** and of the diametrically opposite generatrix. **Figure 2** shows a marker **252** with a diamond shape and a small thickness provided along the outer sheath **114** at a desirable position for determining the rotational position of the catheter within the bifurcation. The markers **250**, **252**, **254** may be impressed on the core **112**, on the sheath **114**, or directly on the stents **12**, **14** such as on the bridge **18**, and not on the sheath **114**.

With reference to **Figures 10 and 10A**, three markers **253** are shown disposed at a distal end of the second stent **14** and spaced at 120° relative to one another. Three markers **254** are also disposed at a proximal end of the first stent **12**, and spaced at 120° relative to one another. Each stent **12**, **14** also includes a single marker **250**, **210** at its opposite end (e.g. the first stent **12** has a single marker **250** at its distal end, and the second stent **14** has a

single marker **210** at its proximal end). Of course, other marker arrangements may be used as desired by the skilled artisan.

5 A central marker **252** makes it possible to visualize, with the aid of a suitable radiography apparatus, the position of a bridge **18** separating the two stents **12, 14**. Thus allowing a specialist to visualize the location of the second stent **14** so that it can be correctly positioned in relation to the widened zone **46**. The end markers **250A** allow a specialist to ensure that the stents **12, 14** are correctly positioned, respectively, in the main/principal conduit **32** and the secondary/branch conduit **34**.

10 A diamond-shaped marker **252** as shown in Figure **2** is, for its part, visible in a plan view or an edge view, depending on whether it is oriented perpendicular or parallel to the radius of the radiography apparatus. It thus makes it possible to identify the angular orientation of the stents **12, 14** in relation to the bifurcation **30**, so that the part of the second stent **14** having the greatest expansion can be placed in an appropriate manner in relation to the widened transition zone **46**.

15 Methods of positioning and deploying a pair of dissimilar stents in an area of a bifurcation will now be discussed with reference to **Figures 3-6 and 13-17**. Although portions of the following discussion refer to delivery of two dissimilar stent portions, those skilled in the art will recognize that a larger or smaller number of stents, and/or stents having similar expanded configurations may also be used while realizing certain aspects of
20 the present invention.

A method of delivering a stent system as described above generally and illustrated in **Figures 13-17** includes locating the bifurcation **30** to be treated, providing a suitable delivery catheter **100**, positioning the distal portion **107** of a delivery catheter with stents **12, 14** disposed thereon in the branch of the bifurcation to be treated, partially deploying
25 the first stent **12** in a branch vessel **34**, observing and adjusting the position of the first stent **12** if necessary, then fully deploying the first stent **12**. The second stent **14** is partially deployed, and preferably the position is again observed such as by infusing contrast media through the pull wire lumen **220** under fluoroscopic visualization. The position of the second stent **14** may be adjusted if necessary, and finally the second stent **14** is fully
30 deployed. Methods of navigating catheters through blood vessels or other fluid conduits within the human body are well known to those skilled in the art, and will therefore not be discussed herein.

The delivery catheter **100** may be constructed according to any of the embodiments described above such that the stents **12**, **14** may be selectively deployed by axially displacing the outer sheath **114** along the delivery catheter, thereby selectively exposing the stent system **10**. This may be accomplished by holding the sheath **114** fixed relative to the bifurcation, and selectively distally advancing the central core **112**. Thus, the present invention contemplates deploying one or more stents by distally advancing the central core (inner sheath) rather than proximally retracting the outer sheath as a mode of stent deployment. The stent system may alternatively be deployed by holding the central core fixed relative to the bifurcation and selectively proximally retracting the sheath **114**. The catheter may also be adapted to allow the sheath to be advanced distally, thereby re-contracting the partially deployed stents on the central core **112** to allow repositioning or removal.

In order to visualize the position of a partially-deployed stent with a suitable radiographic apparatus, a contrast media may be introduced through the catheter to the region of the stent placement. Many suitable contrast media are known to those skilled in the art. The contrast media may be introduced at any stage of the deployment of the stent system **10**. For example, a contrast media may be introduced after partially deploying the first stent **12**, after fully deploying the first stent **12**, after partially deploying the second stent **14**, or after fully deploying the second stent **14**.

The degree of deployment of the stent system **10** is preferably made apparent by the indicators on the handpiece **200** as described above. The handpiece **200** and outer sheath are preferably adapted such that a motion of a control on the handpiece **200** results in proximal motion of the outer sheath **114** relative to the distal tip **122** and the stents **12**, **14**. The handpiece **140** and sheath **114** may also be adapted such that the sheath may be advanced distally relative to the stents **12**, **14**, thus possibly re-contracting one of the stents **12**, **14** on the core **112**. This may be accomplished by providing a pull wire **222** having a distal end **223** attached to a portion of the outer sheath **114**, and a proximal end adapted to be attached to the handpiece **200**. Alternatively, the handpiece **200** may be omitted, and the retraction wire **206** may be directly operated by the clinician.

In an alternative embodiment, indicated by Figures 4-6, the first and/or second stent **12**, **14** may be deployed in a single motion, thus omitting the step of re-positioning the stent

12, 14 before fully deploying it. The sheath 114 is then progressively withdrawn, as is shown in **Figures 5** and **6**, in order to permit the complete expansion of the stents **12, 14**.

In a preferred embodiment, the second stent **14** is placed in close proximity to the first stent **12**. For example, the distal end **38** of the second stent **14** may be placed within a distance of about 4 mm of the proximal end **42** of the first stent **12**, more preferably this distance is less than about 2 mm, and most preferably the first and second stents **12, 14** are placed within 1 mm of one another. Those skilled in the art will recognize that the relative positioning of the first and second stents **12, 14** will at least partially depend on the presence or absence of a bridge **18** as discussed above. The axial flexibility of any bridge **18** will also affect the degree of mobility of one of the stents relative to the other. Thus, a stent system **10** will preferably be chosen to best suit the particular bifurcation to be treated.

As mentioned above, the stents **12, 14** may be self-expanding or balloon-expandable (e.g. made of a substantially non-elastic material). Thus the steps of partially deploying the first and/or the second stent may include introducing an inflation fluid into a balloon on which a stent is disposed, or alternatively the stent may be allowed to self-expand. In the case of a balloon-expandable second stent **14**, the balloon **116** (FIG. 12A) on which the second stent **14** is disposed may be specifically adapted to correspond to the particular shape of the second stent **14**. Specifically, such a balloon will preferably have a larger diameter at a distal end than at a proximal end.

After complete expansion of the stents **12, 14**, the distal end of the delivery catheter **100** including the core **112** and the guidewire **170** may be withdrawn from the conduits and the vasculature of the patient. Alternatively, additional stents may also be provided on a delivery catheter, which may also be positioned and deployed in one or both branches of the bifurcation. For example, after deploying the second stent **14** as shown in Figure **6** or **17**, the catheter **100** and guidewire **170** may be retracted and re-positioned in the second branch vessel such that a third stent may be positioned and deployed therein.

Referring to Figure **18**, a second branch stent **13** may be deployed in the second branch, such that both branch vessels in the bifurcation are fully stented. The second branch stent **13** may be either a self expandable or balloon expandable stent such as those well known in the art and disclosed in part elsewhere herein. The second branch stent **13** may be deployed before or after the main stent **14** and/or first branch stent **12**. In one application of the invention, the main vessel stent **14** and first branch stent **12** are

positioned as has been described herein. A stent deployment catheter (not illustrated) such as a balloon catheter or self expanding stent deployment catheter is transluminally advanced to the bifurcation, and advanced through the main vessel stent 14. The second branch vessel stent 13 may then be aligned in the second branch vessel, such that it abuts end to end, is spaced apart from, or overlaps with the distal end of the main branch stent 14. The
5 second branch vessel stent 13 may then be deployed, and the deployment catheter removed.

As will be clear to those skilled in the art, the stent system 10 and stent delivery system 100 described herein is useful in treating a number of pathological conditions commonly found in vascular systems and other fluid conduit systems of human patients.
10 Treatment with the apparatus can include re-establishing the appropriate diameter of a bifurcation in cases of arteriosclerosis or internal cell proliferation, or in rectifying a localized or nonlocalized dissection in the wall of the conduit, or in re-creating a bifurcation of normal diameter while eliminating the aneurysmal pouch in cases of aneurysm.

15 One or more of the stents deployed in accordance with the present invention may be coated with or otherwise carry a drug to be eluted over time at the bifurcation site. Any of a variety of therapeutically useful agents may be used, including but not limited to, for example, agents for inhibiting restenosis, inhibiting platelet aggregation, or encouraging endothelialization. Some of the suitable agents may include smooth muscle cell
20 proliferation inhibitors such as rapamycin, angiopentin, and monoclonal antibodies capable of blocking smooth muscle cell proliferation; anti-inflammatory agents such as dexamethasone, prednisolone, corticosterone, budesonide, estrogen, sulfasalazine, acetyl salicylic acid, and mesalamine, lipoxigenase inhibitors; calcium entry blockers such as verapamil, diltiazem and nifedipine; antineoplastic/antiproliferative/anti-mitotic agents
25 such as paclitaxel, 5-fluorouracil, methotrexate, doxorubicin, daunorubicin, cyclosporine, cisplatin, vinblastine, vincristine, colchicine, epothilones, endostatin, angiostatin, Squalamine, and thymidine kinase inhibitors; L-arginine; antimicrobials such as astriclosan, cephalosporins, aminoglycosides, and nitorfuirantoin; anesthetic agents such as lidocaine, bupivacaine, and ropivacaine; nitric oxide (NO) donors such as lisidomine, molsidomine,
30 NO-protein adducts, NO-polysaccharide adducts, polymeric or oligomeric NO adducts or chemical complexes; anti-coagulants such as D-Phe-Pro-Arg chloromethyl ketone, an RGD peptide-containing compound, heparin, antithrombin compounds, platelet receptor

antagonists, anti-thrombin antibodies, anti-platelet receptor antibodies, enoxaparin, hirudin, Warafin sodium, Dicumarol, aspirin, prostaglandin inhibitors, platelet inhibitors and tick antiplatelet factors; interleukins, interferons, and free radical scavengers; vascular cell growth promoters such as growth factors, growth factor receptor antagonists, transcriptional
5 activators, and translational promoters; vascular cell growth inhibitors such as growth factor inhibitors (e.g., PDGF inhibitor--Trapidil), growth factor receptor antagonists, transcriptional repressors, translational repressors, replication inhibitors, inhibitory antibodies, antibodies directed against growth factors, bifunctional molecules consisting of a growth factor and a cytotoxin, bifunctional molecules consisting of an antibody and a
10 cytotoxin; Tyrosine kinase inhibitors, chymase inhibitors, e.g., Tranilast, ACE inhibitors, e.g., Enalapril, MMP inhibitors, (e.g., Ilomastat, Metastat), GP IIb/IIIa inhibitors (e.g., Intergrilin, abciximab), serotonin antagonist, and 5-HT uptake inhibitors; cholesterol-lowering agents; vasodilating agents; and agents which interfere with endogeneous vasoactive mechanisms. Polynucleotide sequences may also function as anti-restenosis
15 agents, such as p15, p16, p18, p19, p21, p27, p53, p57, Rb, nFkB and E2F decoys, thymidine kinase ("TK") and combinations thereof and other agents useful for interfering with cell proliferation. The selection of an active agent can be made taking into account the desired clinical result and the nature of a particular patient's condition and
20 contraindications.

The bifurcation **30** shown in Figure 3 has excrescences **35** which create a narrowing in cross section, which impedes the flow of the liquid circulating in the conduits **32** and **34**. In the case of a vascular bifurcation, these excrescences are due, for example, to arteriosclerosis or cellular growth. The stent system described herein permits treatment of this bifurcation by re-establishing the appropriate diameter of the conduits **32**, **34** and of the
25 widened transition zone **46**.

As shown in Figure 7, the stent system **10** can also be used to treat an aneurysm **242**. An aneurysm **242** is defined as a localized, pathological, blood-filled dilatation of a blood vessel caused by a disease or weakening of the vessel's wall. Thus it is desirable to provide a "substitute" vessel wall in an area of an aneurysm. For this purpose, the first or
30 second stent **12**, **14** may be at least partially covered by a film **240** which is substantially impermeable to the fluid circulating in the conduits **32**, **34**. Many suitable films are known to those skilled in the art such as polyester, polytetrafluoroethylene (PTFE), high and

medium density polyethylenes, etc. The film may be sewn onto the stents **12, 14**, or it may be folded around a stent such that as the stent is expanded within the vessel **32**, the film **240** is trapped and held between the stent and the vessel wall. The stent then guides the liquid through the bifurcation **30** and consequently prevents stressing of the wall forming the
5 aneurysm **242**.

The stent system described may be adapted as mentioned above to treat any of a number of bifurcations within a human patient. For example, bifurcations of both the left and right coronary arteries, the bifurcation of the circumflex artery, the carotid, femoral, iliac, popliteal, renal or coronary bifurcations. Alternatively this apparatus may be used for
10 nonvascular bifurcations, such as tracheal or biliary bifurcations, for example between the common bile and cystic ducts, or in the area of the bifurcation of the principal bile tract.

Although certain preferred embodiments and examples have been described herein, it will be understood by those skilled in the art that the present inventive subject matter extends beyond the specifically disclosed embodiments to other alternative embodiments and/or uses
15 of the invention and obvious modifications and equivalents thereof. Thus, it is intended that the scope of the present inventive subject matter herein disclosed should not be limited by the particular disclosed embodiments described above, but should be determined only by a fair reading of the claims that follow.

WHAT IS CLAIMED IS:

1. A deployment system, comprising:
an elongate, flexible body, having a proximal end and a distal end;
a first stent on the body, having a first configuration; and
5 a second stent on the body, having a second, different configuration.
2. A deployment system as in Claim 1, comprising a releasable restraint, for retaining the stents on the flexible body.
3. A deployment system as in any of the preceding claims, further comprising at least one inflatable balloon, for expanding at least one stent.
- 10 4. A deployment system as in any of the preceding claims, further comprising a guidewire lumen extending axially through at least a portion of the flexible body.
5. A deployment system as in any of the preceding claims, wherein the guidewire lumen has a proximal access port and a distal access port, and the proximal access port is positioned along the flexible body, spaced distally apart from the proximal
15 end.
6. A deployment system as in any of the preceding claims, wherein the guidewire lumen has a proximal access port and a distal access port, and the proximal access port is positioned at the proximal end of the flexible body.
7. A deployment system as in any of the preceding claims, wherein the
20 releasable restraint comprises an axially movable control element extending along the length of the flexible body.
8. A deployment system as in any of the preceding claims, wherein the releasable restraint comprises a tubular sheath.
9. A deployment system as in any of the preceding claims, wherein the
25 releasable restraint comprises a pull wire.
10. A deployment system as in any of the preceding claims, wherein the releasable restraint comprises a dissolvable media.
11. A deployment system as in any of the preceding claims, wherein the first and second stents have different expanded geometries.
- 30 12. A deployment system as in any of the preceding claims, wherein the first stent has a substantially cylindrical unconstrained expanded configuration, having a proximal end, a distal end and a substantially constant radius throughout.

13. A deployment system as in any of the preceding claims, wherein the second stent has an unconstrained expanded configuration in which a proximal end has a smaller diameter than a distal end.
14. A deployment system as in any of the preceding claims, wherein the expanded diameter of the second stent tapers radially outwardly in the distal direction.
15. A deployment system as in any of the preceding claims, wherein the first and second stents are carried by the catheter such that release of the stents from the catheter causes the proximal end of the first stent and the distal end of the second stent, as implanted, to be separated by a distance of no more than about 4 mm.
16. A deployment system as in any of the preceding claims, wherein the distance separating the proximal end of the first stent and the distal end of the second stent is no more than about 2 mm.
17. A deployment system as in any of the preceding claims, wherein the distance separating the proximal end of the first stent and the distal end of the second stent is no more than about 1 mm.
18. A deployment system according to any of the preceding claims, comprising: a handpiece on the proximal end; and a control on the handpiece, the control having a first position for indicating partial deployment of the first stent, and a second position indicating complete deployment of the first stent.
19. A deployment system as in any of the preceding claims, wherein the control further comprises a third position indicating partial deployment of the second stent.
20. A deployment system as in any of the preceding claims, wherein the control further comprises a fourth position indicating complete deployment of the second stent.
21. A method of deploying first and second stents in the vicinity of a vascular bifurcation of a main vessel into first and second branch vessels, the method comprising the steps of:
- providing a delivery catheter having first and second stents thereon;
 - positioning the catheter such that the first and second stents are in the vicinity of the bifurcation; and
 - deploying the first stent in a branch vessel and the second stent in the main vessel;

wherein the second stent expands to a first diameter at a proximal end and a second, greater diameter at a distal end.

22. A method as in Claim 21, wherein the deploying step includes inflating a balloon within at least one of the stents.

5 23. A method as in Claim 21 or 22, wherein the deploying step comprises permitting at least one stent to self expand.

24. A method as in any of Claims 21-23, wherein the distal end of the second stent is positioned in proximity to the proximal end of the first stent.

10 25. A method as in any of Claims 21-24, wherein the distal end of the second stent expands to a greater diameter than the proximal end of the first stent.

26. A method as in any of Claims 21-25, wherein the distal end of the second stent expands to a diameter that is at least about 110% of the diameter of the proximal end of the first stent.

15 27. A method as in any of Claims 21-26, wherein the distal end of the second stent expands to a diameter that is at least about 105% of the diameter of the proximal end of the first stent.

28. A method as in any of Claims 21-27, further comprising the steps of:
deploying a substantially cylindrical stent in a first branch vessel; and
deploying a tapered stent in the main vessel;

20 wherein both of the substantially cylindrical stent and the tapered stent are deployed from the same catheter.

29. A method of treating a vascular bifurcation as in any of Claims 21-28, wherein at least one of the substantially cylindrical stent and the tapered stent is deployed from a delivery catheter by proximally retracting an outer sheath on the delivery catheter.

25 30. A method of treating a vascular bifurcation as in any of Claims 21-29, wherein the tapered stent has a relatively smaller diameter first end and a larger second end, and the cylindrical stent is positioned adjacent the second end.

30 31. A method as in any of Claims 21-30, further comprising the steps of:
positioning the catheter in the vicinity of the bifurcation;
partially deploying the first stent into the first branch vessel;
introducing contrast media to permit visualization of the location of the first stent; and

completely deploying the first stent into the first branch.

32. A method of treating a bifurcation as in any of Claims 21-31, further comprising the step of partially deploying the second stent in the main vessel.

33. A method of treating a bifurcation as in any of Claims 21-32, further
5 comprising the step of introducing contrast media to permit visualization of the partially deployed second stent in the main vessel.

34. A method of treating a bifurcation as in any of Claims 21-33, further comprising the step of completely deploying the second stent in the main vessel.

35. A method of treating a bifurcation as in any of Claims 21-34, wherein the
10 completely deploying the first stent step comprises proximally retracting a tubular sheath.

36. A method of treating a bifurcation as in any of Claims 21-35, wherein the completely deploying the second stent step comprises proximally retracting the tubular sheath.

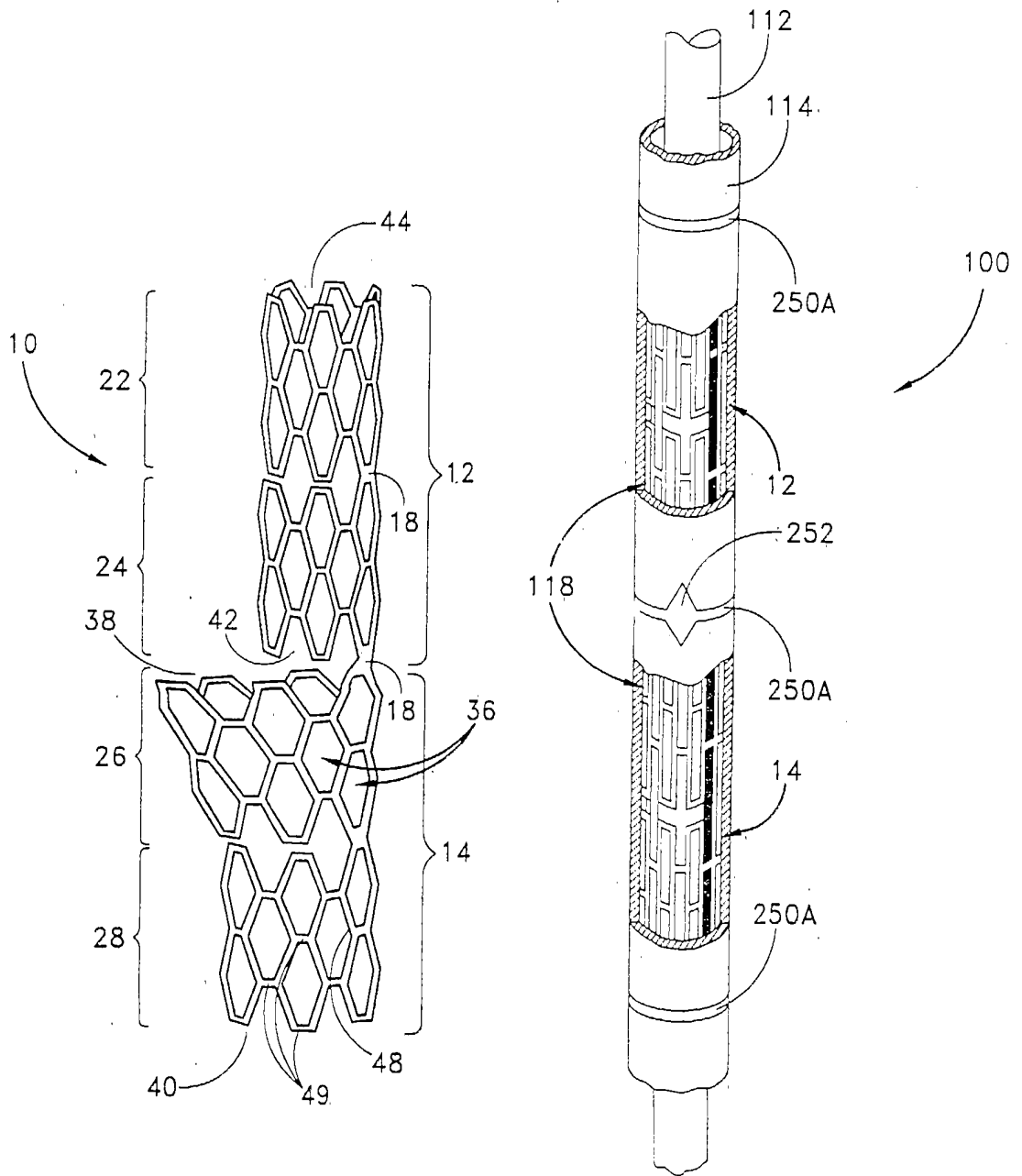

FIG. 1

FIG. 2

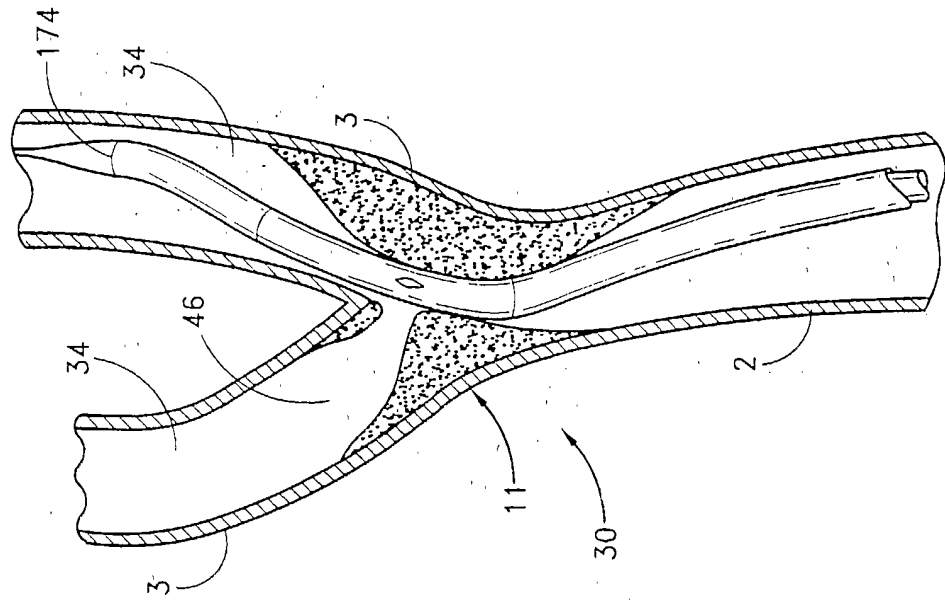

FIG. 4

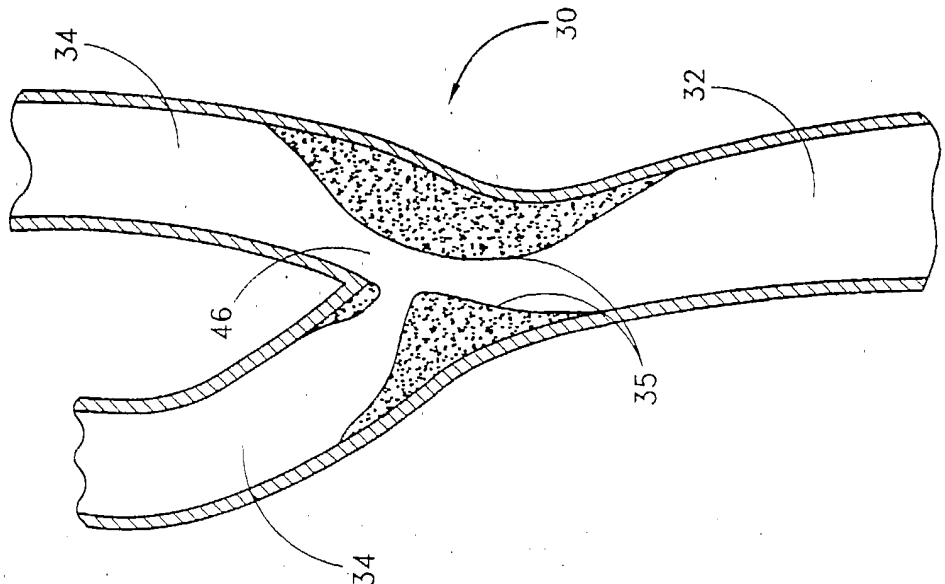

FIG. 3

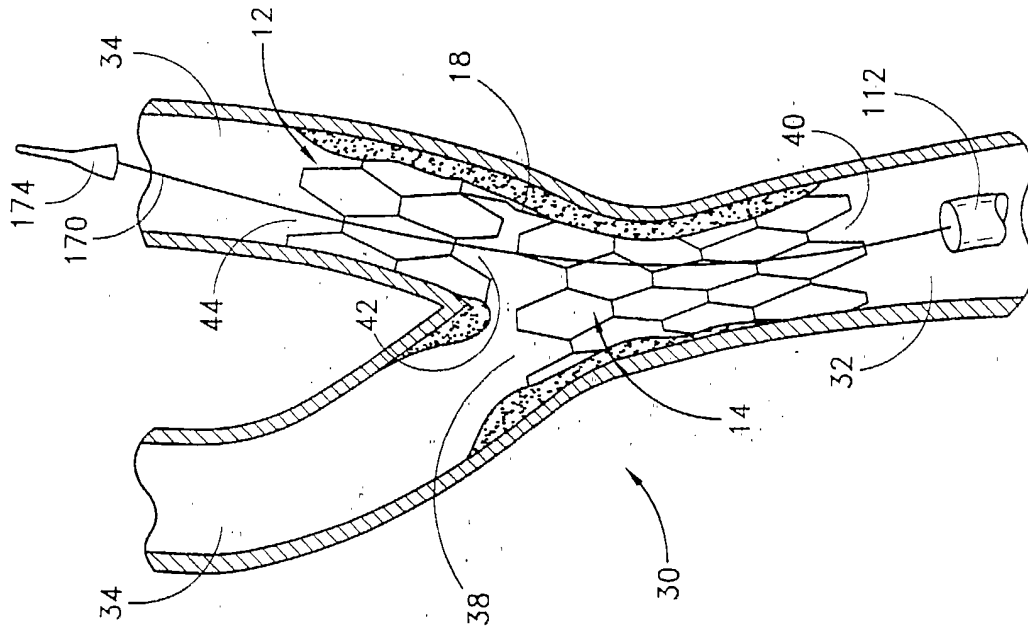

FIG. 6

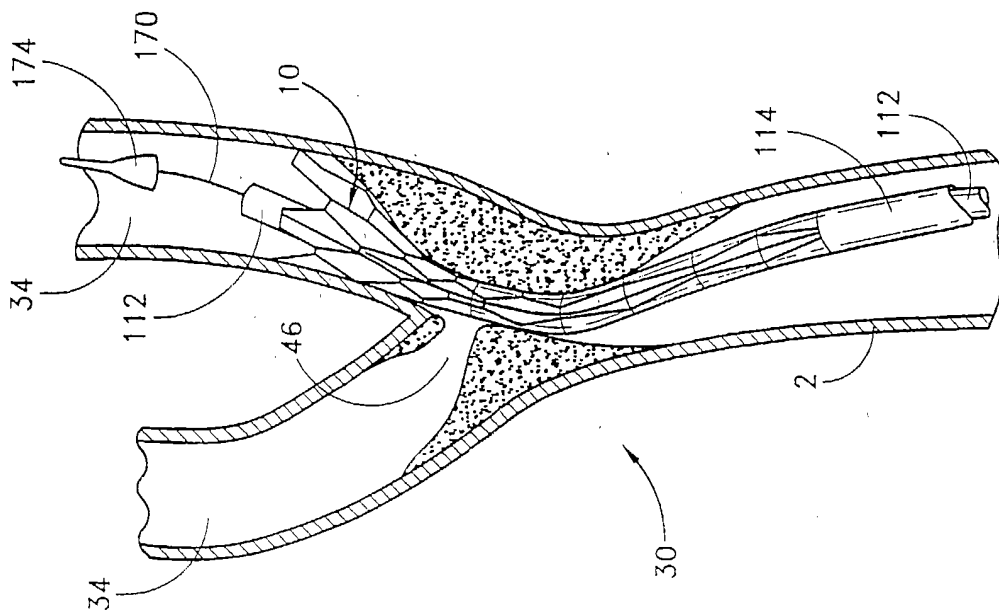

FIG. 5

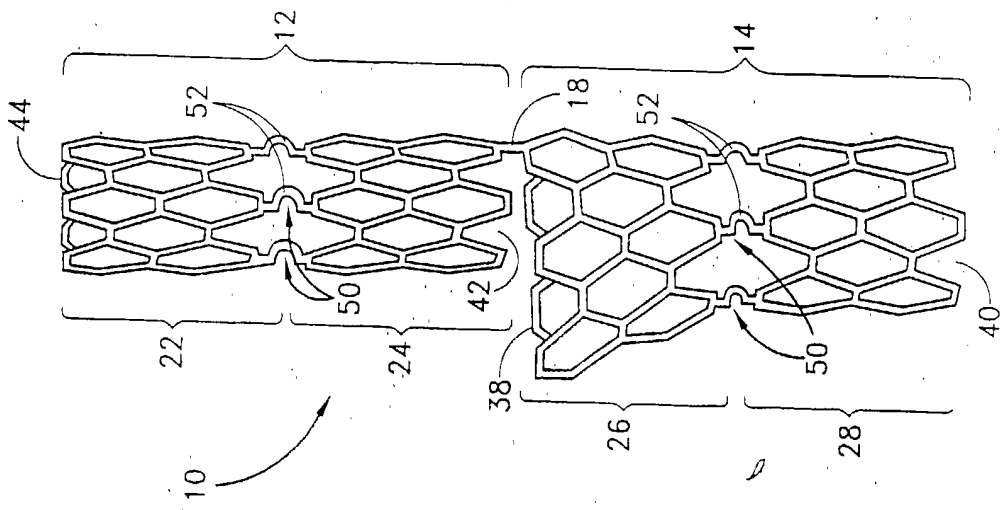

FIG. 8

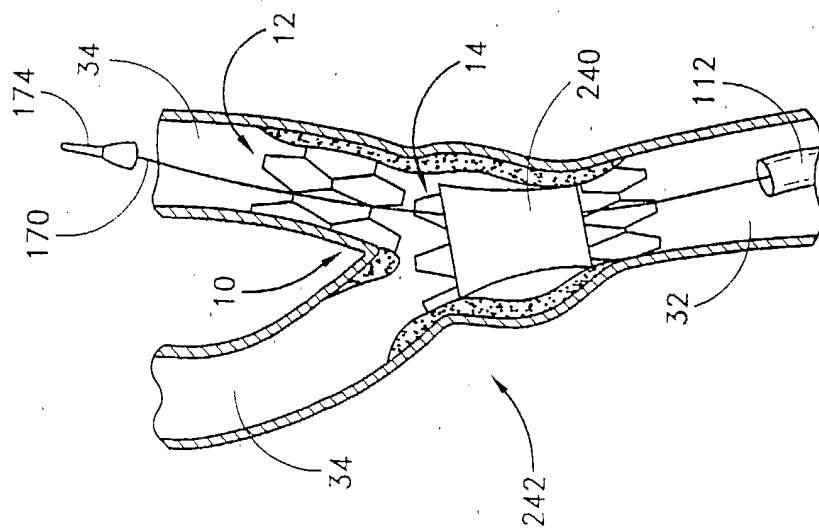

FIG. 7

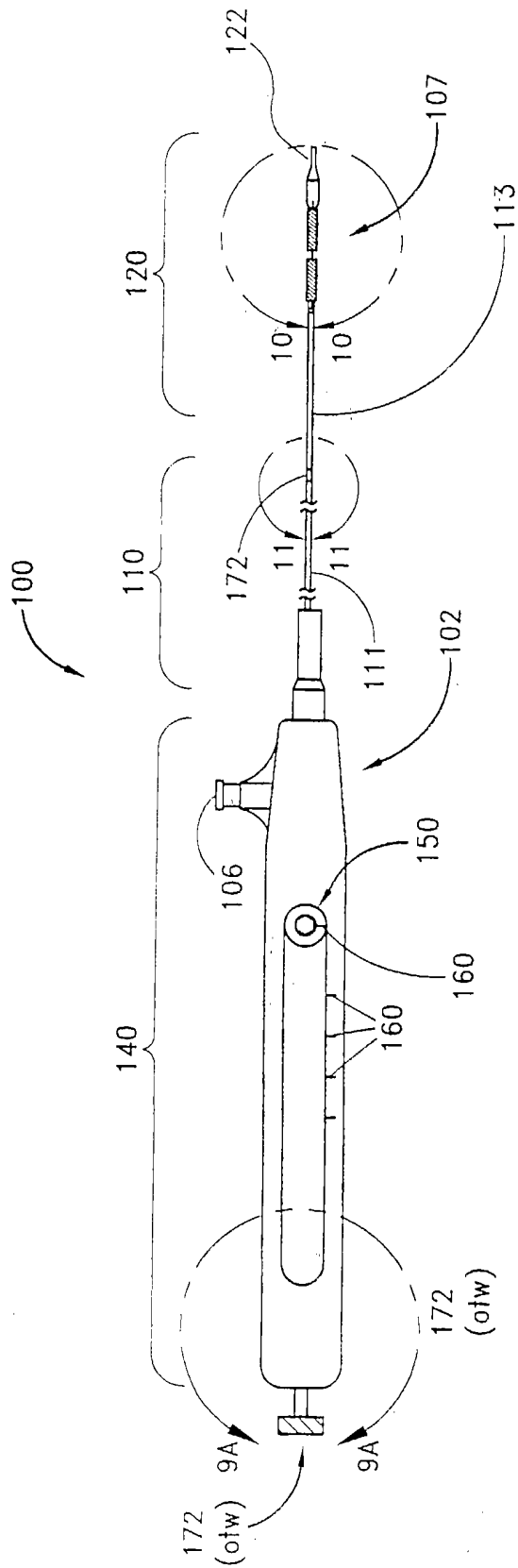

FIG. 9

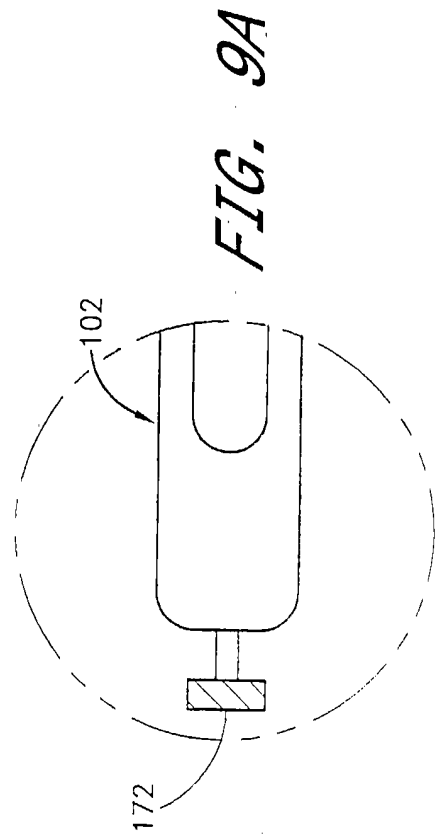

FIG. 9A

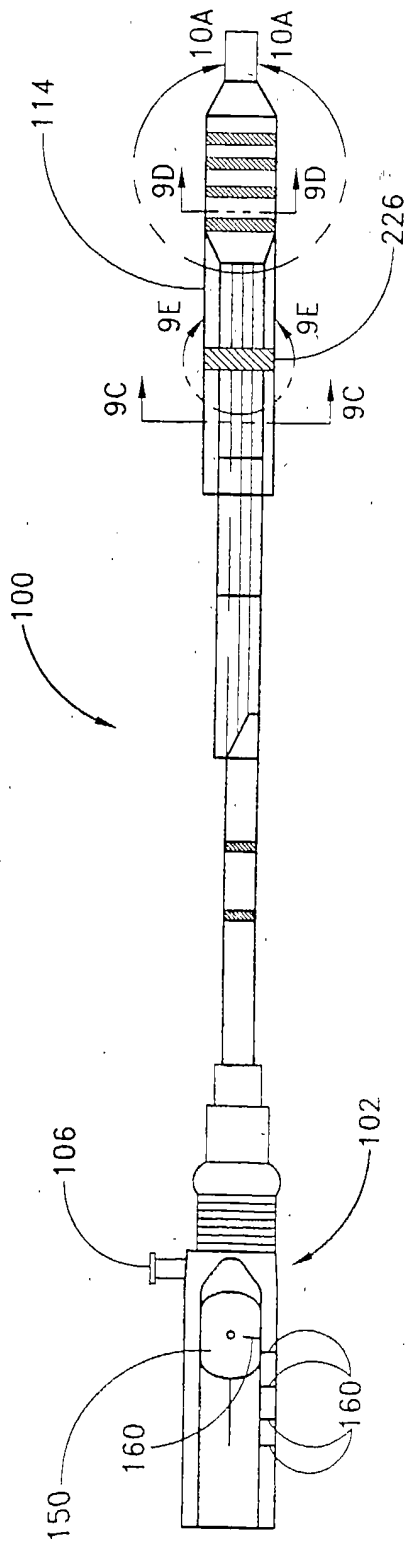

FIG. 9B

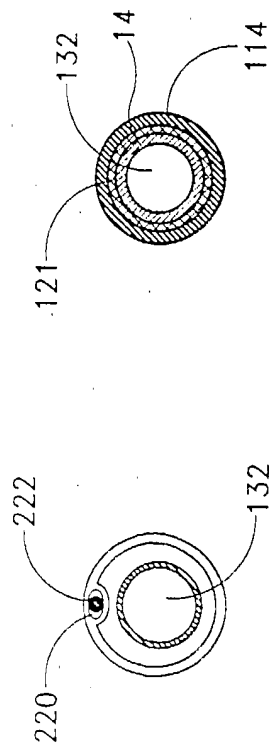

FIG. 9C

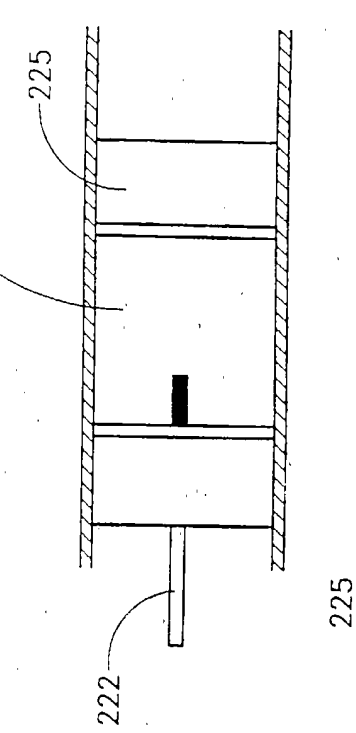

FIG. 9E

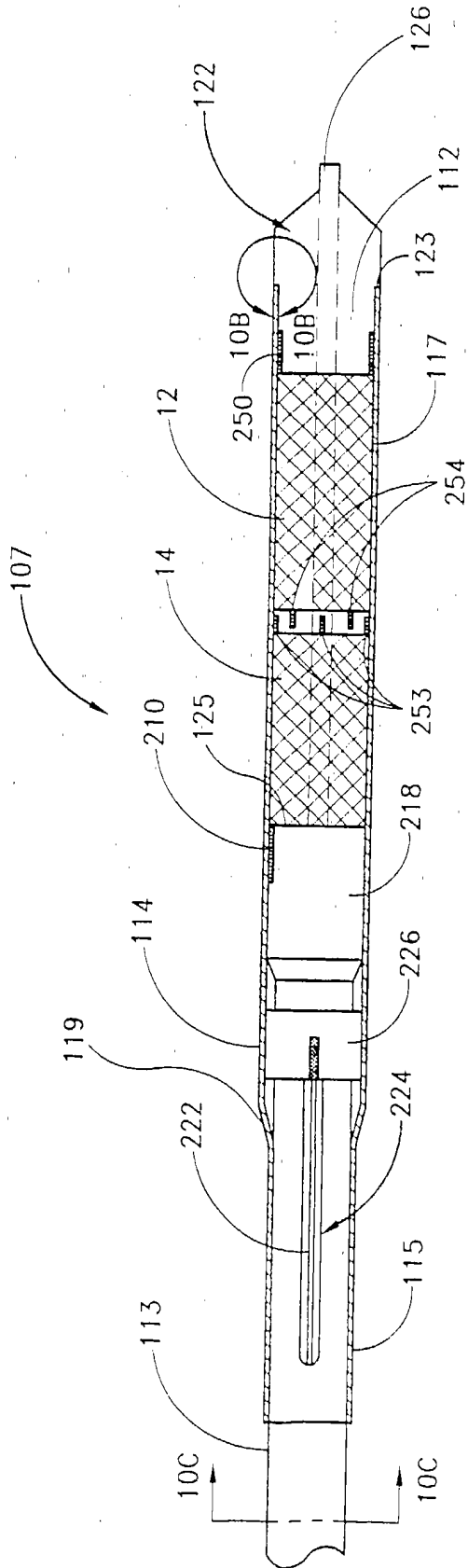

FIG. 10

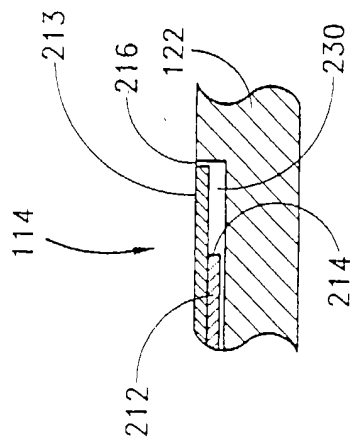

FIG. 10B

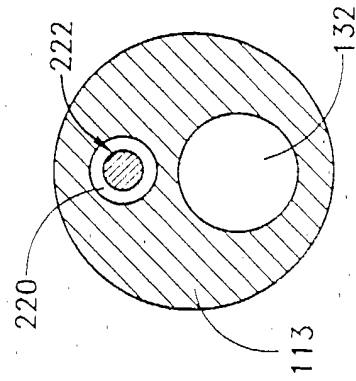

FIG. 10C

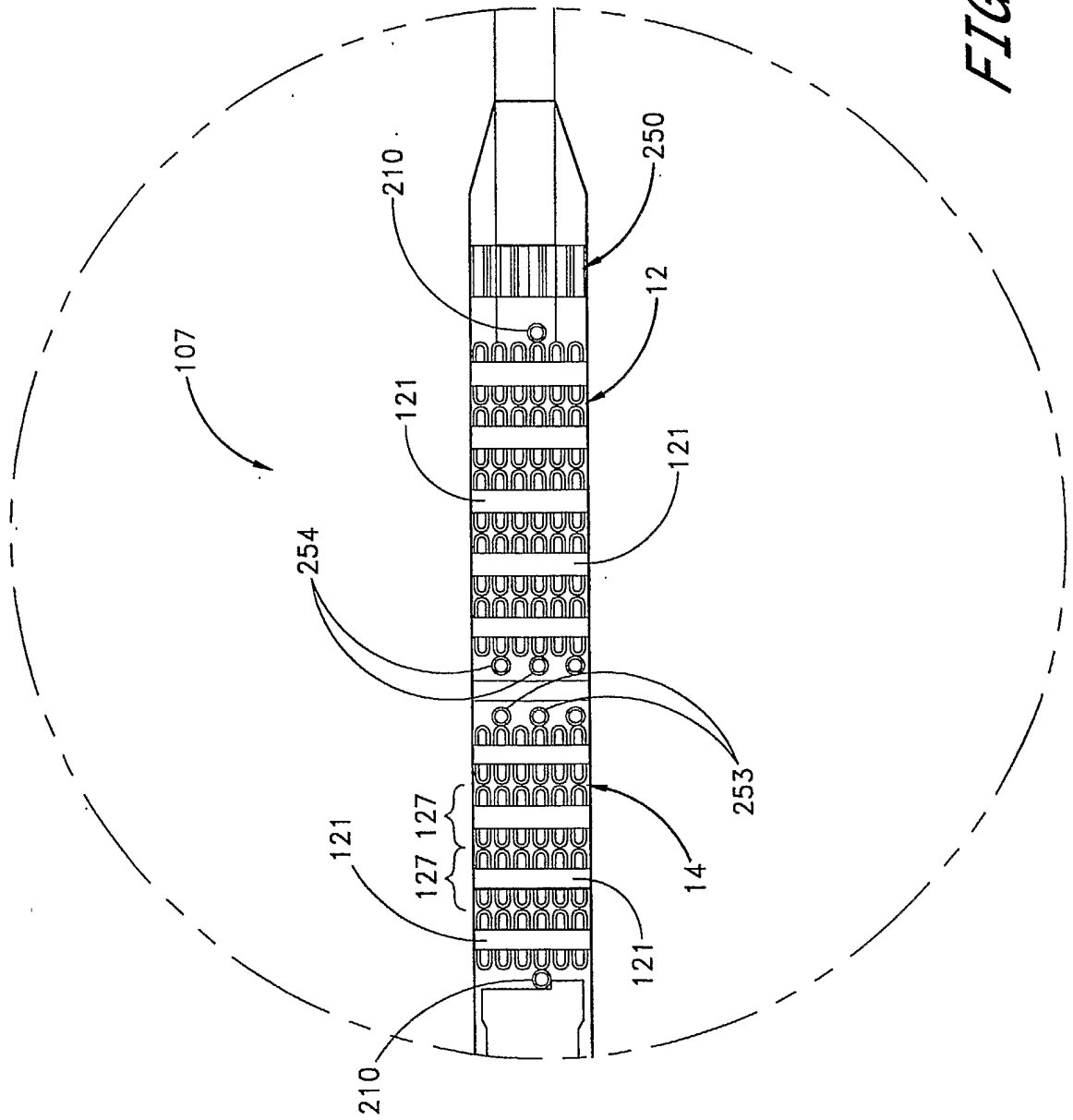

FIG. 10A

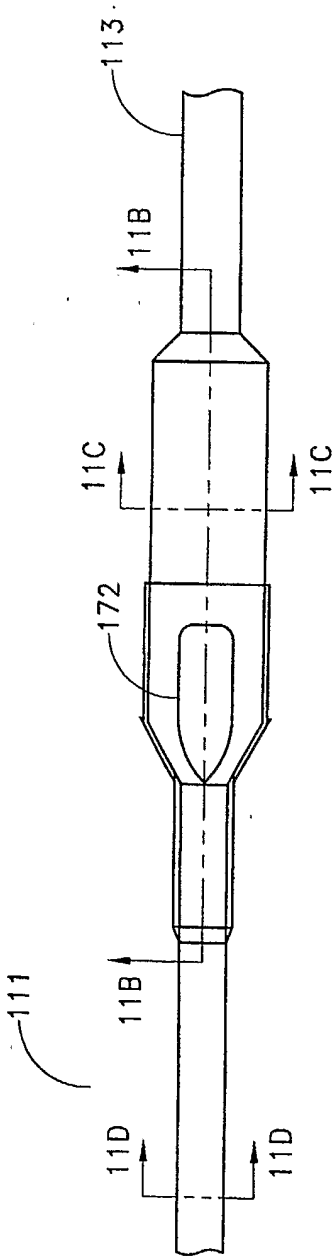

FIG. 11A

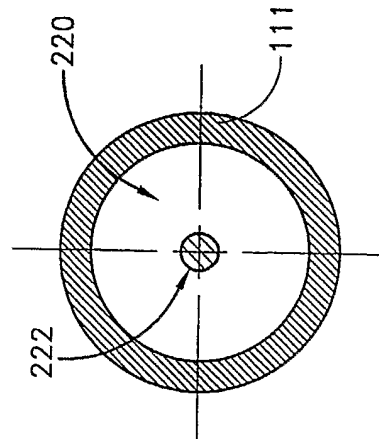

FIG. 11D

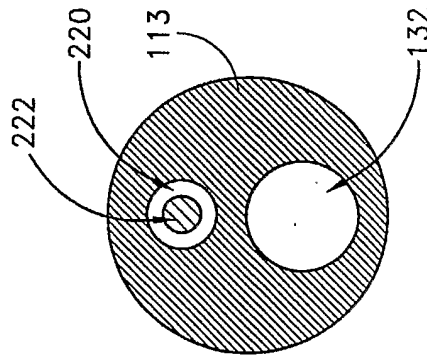

FIG. 11C

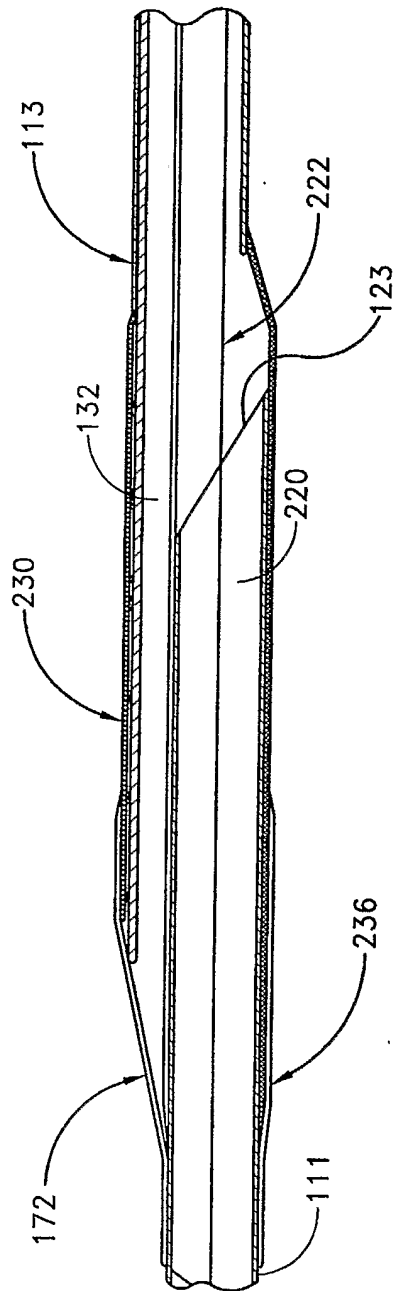

FIG. 11B

11/14

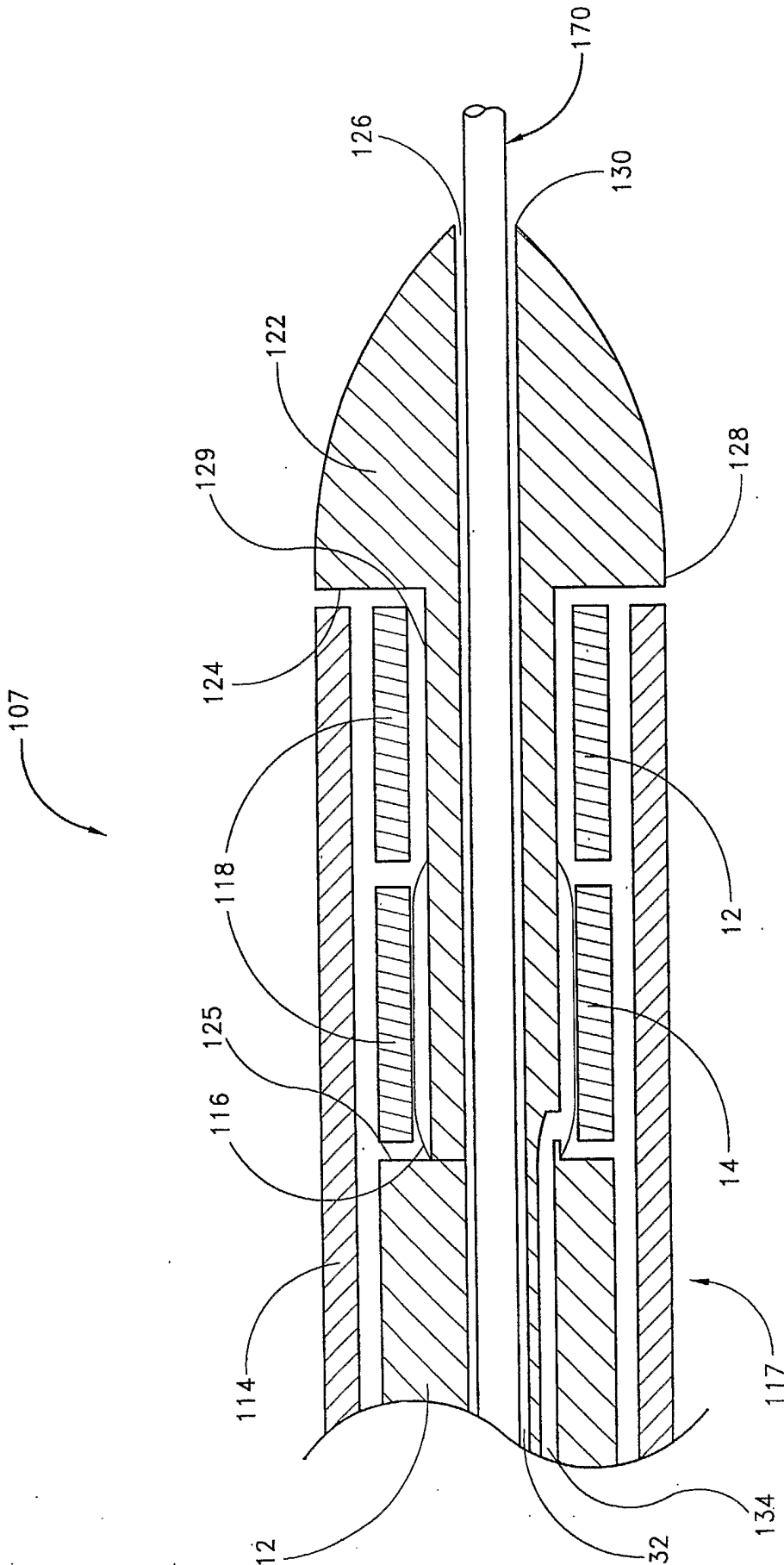

FIG. 12

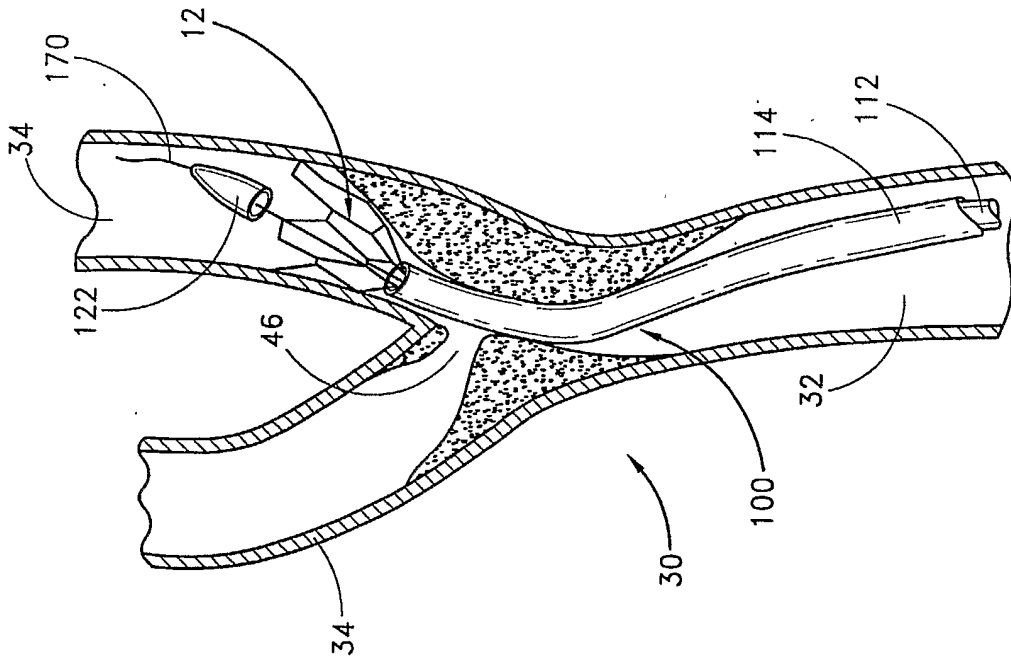

FIG. 14

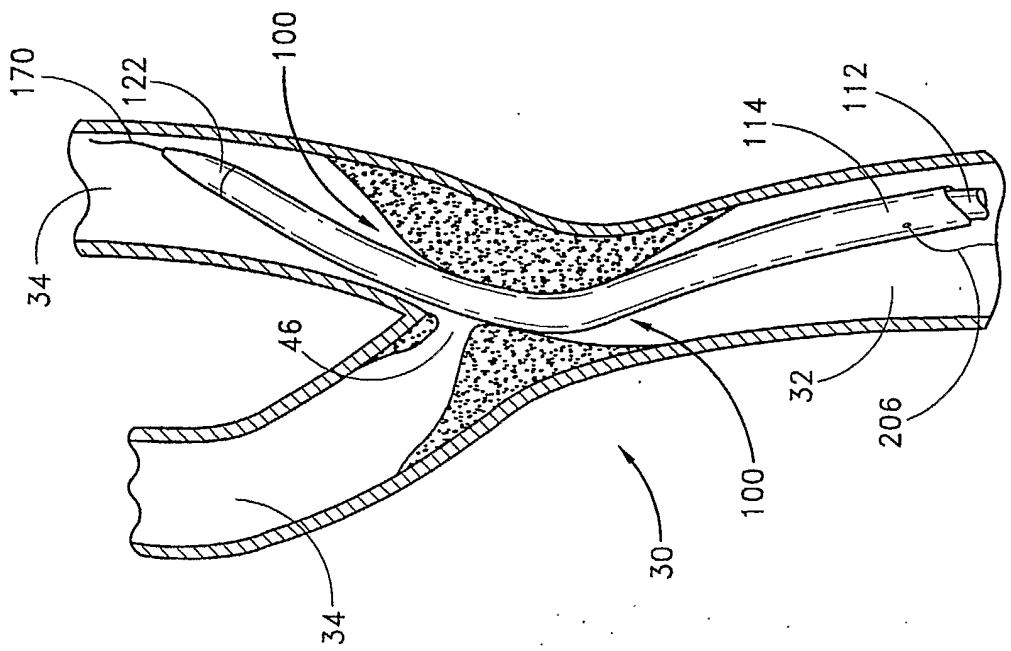

FIG. 13

13/14

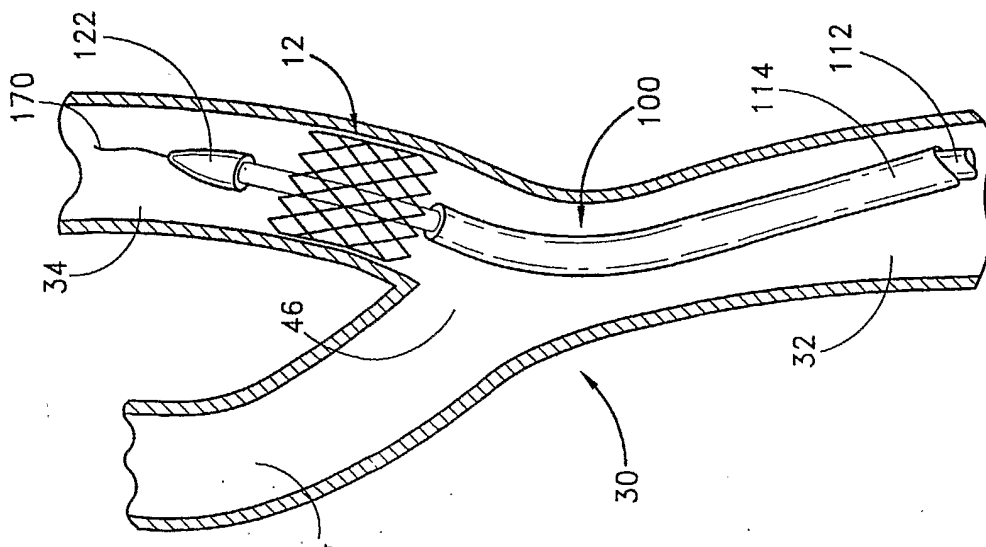
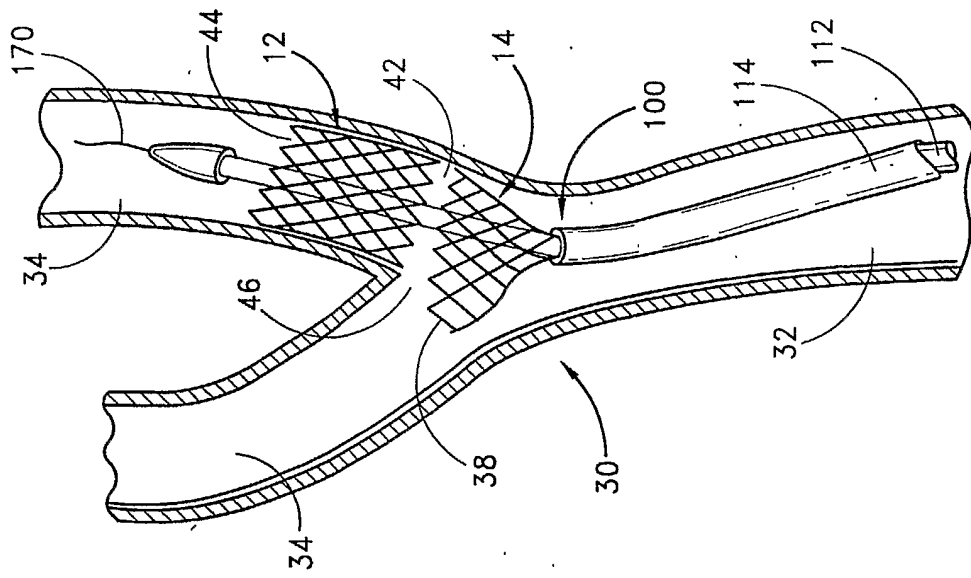
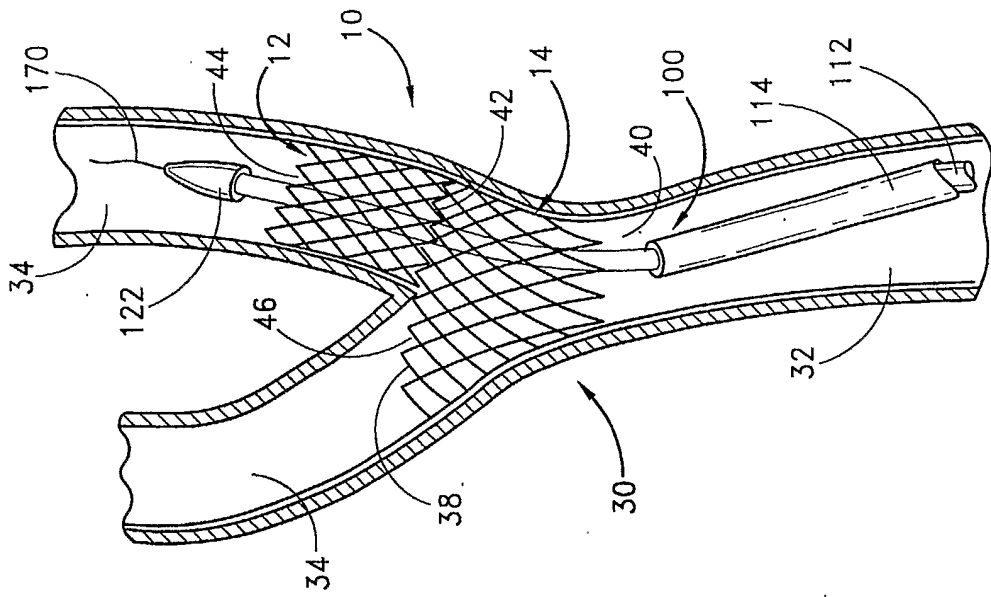

FIG. 15

FIG. 16

FIG. 17

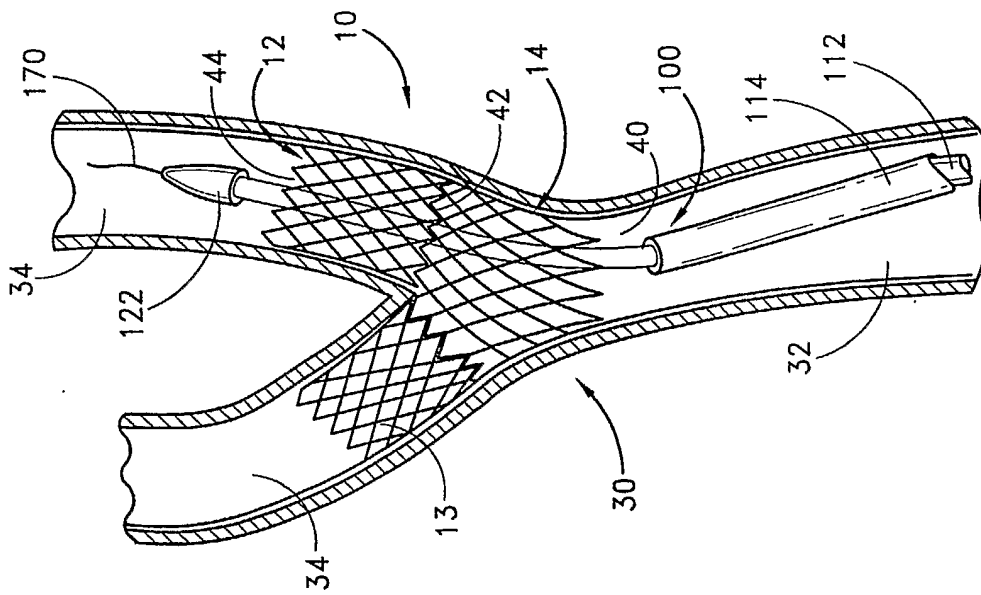

FIG. 18

INTERNATIONAL SEARCH REPORT

Internat Application No

PCT/US 03/25988

A. CLASSIFICATION OF SUBJECT MATTER

IPC 7 A61F2/06

According to International Patent Classification (IPC) or to both national classification and IPC

B. FIELDS SEARCHED

Minimum documentation searched (classification system followed by classification symbols)

IPC 7 A61F

Documentation searched other than minimum documentation to the extent that such documents are included in the fields searched

Electronic data base consulted during the international search (name of data base and, where practical, search terms used)

EPO-Internal

C. DOCUMENTS CONSIDERED TO BE RELEVANT

Category °	Citation of document, with indication, where appropriate, of the relevant passages	Relevant to claim No.
X	WO 01 60284 A (LOALDI ALESSANDRO ; E V R ENDOVASCULAR RES ES S A (LU)) 23 August 2001 (2001-08-23) page 13, line 21 -page 41, line 17	1-7,9, 11,12, 15-20
Y	---	10
Y	US 5 234 457 A (STRECKER ERNEST P ET AL) 10 August 1993 (1993-08-10) column 4, line 28 -column 8, line 59	10
X	US 6 409 755 B1 (VRBA ANTHONY C) 25 June 2002 (2002-06-25) figures 7,8 column 2, line 6 -column 3, line 20 --- -/--	1-3,8, 11-17

Further documents are listed in the continuation of box C.

Patent family members are listed in annex.

° Special categories of cited documents :

- *A* document defining the general state of the art which is not considered to be of particular relevance
- *E* earlier document but published on or after the international filing date
- *L* document which may throw doubts on priority claim(s) or which is cited to establish the publication date of another citation or other special reason (as specified)
- *O* document referring to an oral disclosure, use, exhibition or other means
- *P* document published prior to the international filing date but later than the priority date claimed

- *T* later document published after the international filing date or priority date and not in conflict with the application but cited to understand the principle or theory underlying the invention
- *X* document of particular relevance; the claimed invention cannot be considered novel or cannot be considered to involve an inventive step when the document is taken alone
- *Y* document of particular relevance; the claimed invention cannot be considered to involve an inventive step when the document is combined with one or more other such documents, such combination being obvious to a person skilled in the art.
- * & * document member of the same patent family

Date of the actual completion of the international search

29 December 2003

Date of mailing of the international search report

08/01/2004

Name and mailing address of the ISA

European Patent Office, P.B. 5818 Patentlaan 2
NL - 2280 HV Rijswijk
Tel. (+31-70) 340-2040, Tx. 31 651 epo nl,
Fax: (+31-70) 340-3016

Authorized officer

Mary, C

INTERNATIONAL SEARCH REPORT

Intern. Application No

PCT, US J3/25988

C.(Continuation) DOCUMENTS CONSIDERED TO BE RELEVANT

Category °	Citation of document, with indication, where appropriate, of the relevant passages	Relevant to claim No.
P,X	US 2003/144724 A1 (MURRAY ROBERT) 31 July 2003 (2003-07-31) figures 1-6 paragraph '0010! - paragraph '0016! -----	1,13,14
P,X	US 2003/093109 A1 (MAUCH KEVIN M) 15 May 2003 (2003-05-15) figures 5-12 paragraph '0038! - paragraph '0048! -----	1

INTERNATIONAL SEARCH REPORT

International application No.
PCT/US 03/25988

Box I Observations where certain claims were found unsearchable (Continuation of item 1 of first sheet)

This International Search Report has not been established in respect of certain claims under Article 17(2)(a) for the following reasons:

1. Claims Nos.: 21-36
because they relate to subject matter not required to be searched by this Authority, namely:
Rule 39.1(iv) PCT - Method for treatment of the human or animal body by surgery
2. Claims Nos.:
because they relate to parts of the International Application that do not comply with the prescribed requirements to such an extent that no meaningful International Search can be carried out, specifically:
3. Claims Nos.:
because they are dependent claims and are not drafted in accordance with the second and third sentences of Rule 6.4(a).

Box II Observations where unity of invention is lacking (Continuation of item 2 of first sheet)

This International Searching Authority found multiple inventions in this international application, as follows:

1. As all required additional search fees were timely paid by the applicant, this International Search Report covers all searchable claims.
2. As all searchable claims could be searched without effort justifying an additional fee, this Authority did not invite payment of any additional fee.
3. As only some of the required additional search fees were timely paid by the applicant, this International Search Report covers only those claims for which fees were paid, specifically claims Nos.:
4. No required additional search fees were timely paid by the applicant. Consequently, this International Search Report is restricted to the invention first mentioned in the claims; it is covered by claims Nos.:

Remark on Protest

- The additional search fees were accompanied by the applicant's protest.
- No protest accompanied the payment of additional search fees.

INTERNATIONAL SEARCH REPORT

Intern: Application No
PCT/US 03/25988

Patent document cited in search report	Publication date	Patent family member(s)	Publication date
WO 0160284	A	23-08-2001	AT 248558 T 15-09-2003
			AU 3726401 A 27-08-2001
			BR 0017126 A 05-03-2003
			CA 2399439 A1 23-08-2001
			CN 1434690 T 06-08-2003
			DE 60005062 D1 09-10-2003
			WO 0160284 A1 23-08-2001
			EP 1255506 A1 13-11-2002
			JP 2003522590 T 29-07-2003
			TR 200202014 T2 21-02-2003
			US 2003187494 A1 02-10-2003
			US 5234457
DE 69228260 D1 04-03-1999			
DE 69228260 T2 12-08-1999			
EP 0680278 A1 08-11-1995			
JP 7500265 T 12-01-1995			
WO 9306781 A1 15-04-1993			
US 6305436 B1 23-10-2001			
US 5662713 A 02-09-1997			
US 6505654 B1 14-01-2003			
US 6355070 B1 12-03-2002			
US 5876445 A 02-03-1999			
US 6146416 A 14-11-2000			
US 6409755	B1	25-06-2002	US 2002133218 A1 19-09-2002
US 2003144724	A1	31-07-2003	WO 03063734 A1 07-08-2003
US 2003093109	A1	15-05-2003	US 6494875 B1 17-12-2002
			US 6117117 A 12-09-2000
			AU 5579499 A 14-03-2000
			CA 2338833 A1 02-03-2000
			EP 1107709 A1 20-06-2001
			JP 2002523137 T 30-07-2002
			WO 0010489 A1 02-03-2000
			US 6210380 B1 03-04-2001
			US 6258073 B1 10-07-2001
US 2001012927 A1 09-08-2001			