

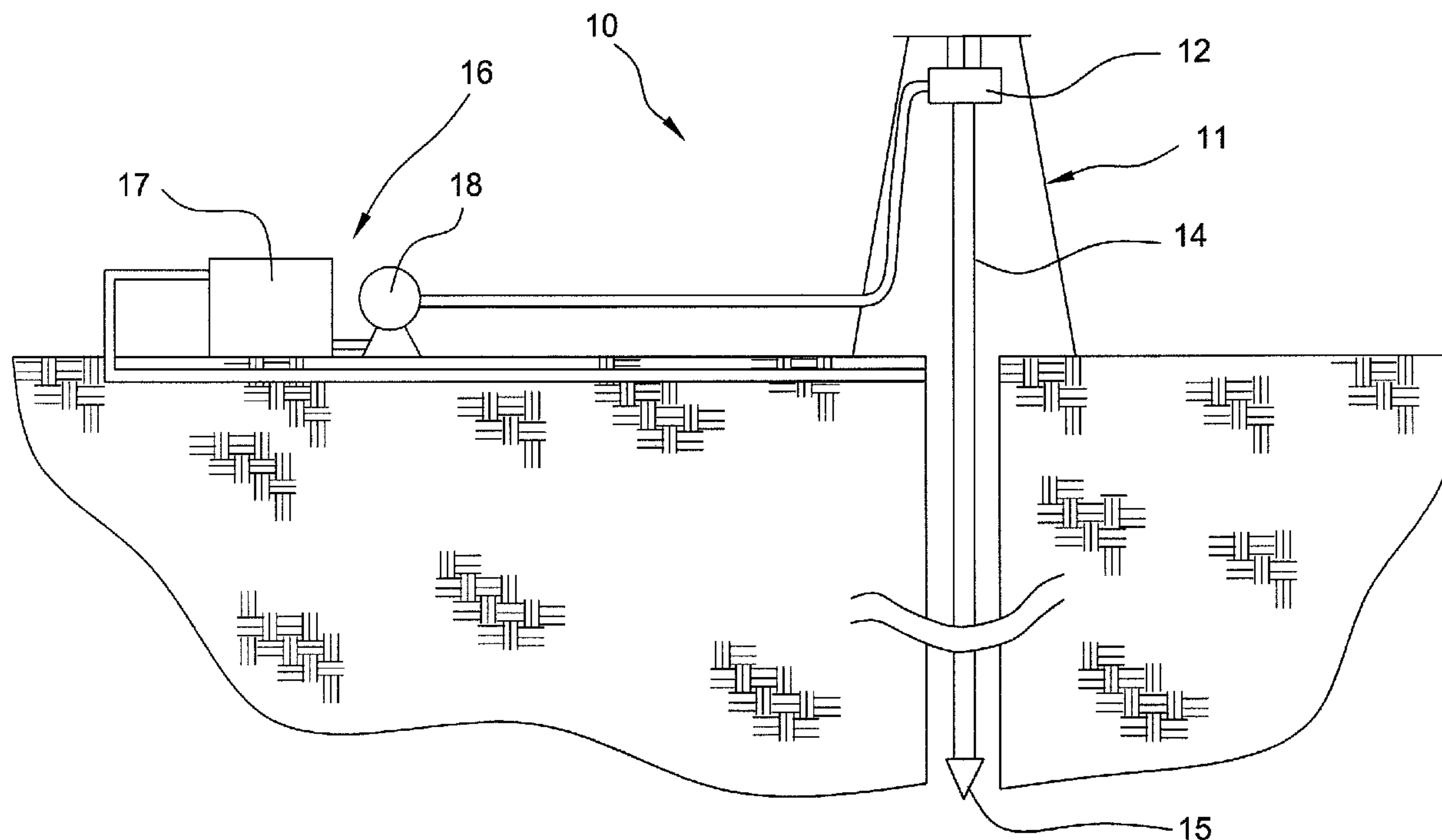

(22) Date de dépôt/Filing Date: 2001/08/09
(41) Mise à la disp. pub./Open to Public Insp.: 2002/02/14
(30) Priorité/Priority: 2000/08/14 (09/638,564) US

(51) Cl.Int.⁷/Int.Cl.⁷ C09K 7/02, E21B 7/00
(71) Demandeur/Applicant:
GRAIN PROCESSING CORPORATION, US
(72) Inventeurs/Inventors:
RILEY, MICHAEL, US;
SCHILLING, KEVIN H., US
(74) Agent: MARKS & CLERK

(54) Titre : LIQUIDE DE FORAGE, APPAREIL ET METHODE
(54) Title: DRILLING FLUID, APPARATUS, AND METHOD



(57) **Abrégé/Abstract:**

Disclosed are drilling fluids suitable for use in connection with oil well drilling. The drilling fluids of the invention include a liquid base, an alkyl glucoside, such as methyl glucoside, and a borehole stability agent that includes a maltodextrin, a carboxyalkyl starch, a hemicellulose-containing material, or a mixture of the foregoing. The drilling fluids of the invention surprisingly have a reduced tendency to swell shale as compared with drilling fluids that do not include hemicellulose or maltodextrin. Also disclosed are a drilling apparatus and process. The drilling apparatus includes a drill string, which may be conventional, that is fluidically coupled to a source of drilling fluid, the source of drilling fluid including the drilling fluid of the invention. The process of the invention includes the step of circulating the drilling fluid of the invention through a drill string during borehole drilling.

ABSTRACT

Disclosed are drilling fluids suitable for use in connection with oil well drilling. The drilling fluids of the invention include a liquid base, an alkyl glucoside, such as methyl glucoside, and a borehole stability agent that includes a maltodextrin, a carboxyalkyl starch, a hemicellulose-containing material, or a mixture of the foregoing. The drilling fluids of the invention surprisingly have a reduced tendency to swell shale as compared with drilling fluids that do not include hemicellulose or maltodextrin. Also disclosed are a drilling apparatus and process. The drilling apparatus includes a drill string, which may be conventional, that is fluidically coupled to a source of drilling fluid, the source of drilling fluid including the drilling fluid of the invention. The process of the invention includes the step of circulating the drilling fluid of the invention through a drill string during borehole drilling.

DRILLING FLUID, APPARATUS, AND METHOD

TECHNICAL FIELD OF THE INVENTION

5 The invention is in the area of drilling fluids used in connection with drilling wells, such as oil wells and water wells. The invention is also directed towards a drilling apparatus and process.

BACKGROUND OF THE INVENTION

10 In drilling a well or other similar borehole, a drill bit is operatively coupled, usually by a drill string, to a drive which rotates the drill bit to cause the drill bit to bore into the earth. A drilling fluid, or drilling mud, is circulated through the borehole annulus. The
15 drilling fluid passes through the drilling string and to the surface through the drill bit for cooling and lubricating the drill bit and for carrying rock cuttings generated by the cutting action of the bit to the surface. The drilling fluid may be a gas, but more typically is a
20 liquid.

Many liquids suitable for use as drilling fluids are known. Some drilling fluids are oil-based. Such oil-based fluids suffer from a number of drawbacks, particularly, their adverse effects on the environment.
25 Oil-based fluids also can be costly to purchase and to dispose of.

Other drilling fluids are water-based or constitute an emulsion of oil in water or water in oil. Such fluids often are inexpensive compared to oil-based fluids, and
30 are less costly to dispose of. Water-based fluids also pose less of a risk to the environment than do oil-based fluids. One drawback associated with water-based fluids is that the water in the fluid tends to promote borehole instability, particularly when shale is encountered in the
35 drilling process. The water-based fluid may adsorb and absorb into pores in the shale, thus causing the shale to

swell and thereby tending to cause the borehole to collapse.

In recognition of this drawback, water-based drilling fluids have incorporated an alkyl glycoside, such as methyl glucoside, into the drilling fluid. It is known that methyl glucoside serves as a borehole stabilizing agent that functions by inhibiting shale swelling. The mechanism of action of methyl glucoside is not fully understood, but is believed to be associated with gel formation or an ion exchange phenomenon. It is generally believed that the methyl glucoside, in adding gel strength to the drilling fluid, causes more rapid formation of filter cake on the borehole wall thereby allowing less water filtrate to reach the surrounding shales. This is believed to reduce swelling and sloughing of the shale.

While known drilling fluids that include methyl glucoside are satisfactory, there remains room for improvement in such fluids in the area of borehole stability. It is a general object of the invention to provide a drilling fluid that is suitable for use in borehole drilling. Another general object is to provide a drilling apparatus and process that incorporate the drilling fluid of the invention.

25

THE INVENTION

It has now been discovered that both maltodextrins, on the one hand, and hemicellulose-containing materials, on the other hand, function to assist glycosides in promoting borehole stability in a drilling fluid. It has further been found that carboxyalkyl starches, in particular carboxymethyl starches, also function to assist glycosides in promoting borehole stability. Surprisingly, these ingredients promote borehole stability more so than other organic species of similar origin or chemical structure when used in conjunction with an alkyl glucoside. In accordance with the invention, a drilling

35

fluid comprises a liquid base, an alkyl glycoside, which preferably is methyl glucoside; and a borehole stability agent that comprises a maltodextrin, a carboxyalkyl starch, and/or hemicellulose. Also encompassed by the invention is a drilling fluid that includes methyl glucoside and cellulose. The invention also encompasses a drilling apparatus and a process for drilling. The drilling apparatus comprises a drilling string that is fluidically coupled to a source of drilling fluid, the drilling fluid including in one embodiment a liquid base, an alkyl glycoside, and one or more of a maltodextrin, a carboxyalkyl starch, and a hemicellulose-containing material and, in another embodiment, a liquid base, an alkyl glycoside, and cellulose. The process of the invention includes the steps of circulating the drilling fluid of the invention through a drill string as a borehole is cut into the earth.

Other features and embodiments of the invention are discussed hereinbelow and are set forth in the pending claims.

BRIEF DESCRIPTION OF THE DRAWING

The Figure is a schematic representation of an oil well drilling apparatus.

DESCRIPTION OF THE PREFERRED EMBODIMENTS

The drilling fluid of the invention generally comprises a liquid base, an alkyl glycoside, and a borehole stability agent, and may include other components and additives as may be deemed appropriate. The liquid base used in the drilling fluid of the invention comprises water, a water-miscible liquid, or a mixture of a water-miscible liquid with water. If the liquid base includes water, the water may be provided from any suitable source. For example, when the oil drilling apparatus is off-shore or near the ocean, sea water is the preferred liquid base

inasmuch as it is freely available. The water may also comprise treated water, softened water, tap water, natural or artificial brine, or other suitable water source. The water miscible liquid may be glycerine, polyglycerine, a polyether, a polyol, or other suitable water miscible liquid. The liquid base may be present in any amount suitable to carry, dissolve and/or suspend the components of the drilling fluid. Preferably, the liquid base is present in the drilling fluid in a total amount ranging from about 5 to about 7.5, more preferably, about 5.5 to about 6 lbs./gallon. It is further contemplated that the liquid base may be used in an oil-based system that comprises an emulsion of oil in water or water in oil.

The drilling fluid of the invention further includes an alkyl glycoside. Alkyl glycosides are a known class of industrial chemicals and are formed by the substitution of the hemiacetal hydroxyl group of a lower order saccharide (i.e., a polysaccharide having a degree of polymerization less than about 7) with an alkyl radical having from one to four carbon atoms. The alkyl radical may be methyl, ethyl, propyl, isopropyl, n-butyl, s-butyl or t-butyl, and the saccharide may be, for example, glucose, maltose, maltotriose, or maltotetraose.

The alkyl glycoside used in conjunction with the invention is preferably methyl glucoside. Most preferably, the methyl glucoside is provided in the form of MeG-206, an aqueous methyl glucoside solution sold by Grain Processing Corporation of Muscatine, Iowa. MeG-206 is a 60% aqueous solution of methyl glucoside, the methyl glucoside being present in a 2:1 ratio of α : β isomers (this ratio should be regarded as approximate). The methyl glucoside also may be provided in the form of MeG-365, also sold by Grain Processing Corporation of Muscatine, Iowa. MEG-365 is a 65% aqueous solution of methyl glucoside which exists in the solution as a 2:1 ratio of α : β isomers (this ratio also should be regarded

as approximate). Another suitable methyl glucoside may be provided as a 70% 1:1 (approximate) mixture of α : β methyl glucoside isomers. More generally, any other suitable mixture of methyl glucoside isomers may be employed in conjunction with the invention.

The alkyl glycoside may be present in any amount effective to inhibit shale swelling. Preferably, when the alkyl glycoside is methyl glucoside, the methyl glucoside is present in the drilling fluid in an amount ranging from about 2 to about 4 lbs./gallon of the drilling fluid (dry basis MeG).

In accordance with the preferred embodiment of the invention, the drilling fluid further includes a borehole stability agent that is selected from among maltodextrins, carboxymethyl starches, and hemicellulose. With respect to hemicellulose, hemicellulose is a term used to refer to a wide variety of heteropolysaccharides found in association with cellulose in plant species. The hemicellulose functions to inhibit shale swelling, and may further function as a fluid loss control agent. The hemicellulose may be added in a purified form, but more preferably is added via the addition of a hemicellulose-containing material, such as an unrefined aqueous slurry (for example, an alkaline digest of corn hulls). Most preferably, the hemicellulose-containing material is produced in accordance with the teachings of U.S. Patent 4,038,481 (Antrim et al.), which discloses the alkalai hydrolysis of corn hulls to yield plural phases including a hemicellulose-rich fraction. The hemicellulose-rich fraction prepared in accordance with the teachings of this patent may be used as the hemicellulose-containing material without subsequent isolation or purification, or this fraction may be concentrated or otherwise modified. The alkali hydrolysis itself preferably is conducted using potassium hydroxide as the alkaline hydrolyzing species. Potassium

is itself believed to function as a shale stability enhancer in a drilling fluid, and thus the potassium hydroxide digest of corn hulls is believed to be particularly suitable for use in conjunction with the invention.

The hemicellulose-containing material is used to provide hemicellulose in the drilling fluid in an amount effective to inhibit swelling of shale. Preferably, if the drilling fluid does not include a maltodextrin, the hemicellulose is present in an amount ranging from about 0.002 to about 0.2 lbs./gallon by dry basis weight. In this embodiment of the invention, these amounts are irrespective of the amount of any cellulose in the drilling fluid.

The drilling fluid may also include a maltodextrin in lieu of or in addition to the hemicellulose-containing material. Maltodextrins are oligo- or poly-saccharides in which the saccharides are linked exclusively or predominantly by 1-4 linkages. In preferred embodiments, at least 50 percent of the saccharide units in the maltodextrin are linked via 1-4 linkages. More preferably, at least about 60 percent of the saccharide units are linked via 1-4 linkages; even more preferably, at least about 80 percent of the saccharide units are so linked. While the drilling fluid may incorporate any maltodextrin or mixture of maltodextrin species, the invention is particularly applicable to mixtures of maltodextrin species in which at least a portion of the maltodextrins in the mixture have a degree of polymerization (DP) greater than 5. Preferably, at least one of the maltodextrin species in the mixture has a DP of 8 or more. More preferably, at least one species has a DP of at least 10. For example, in some embodiments of the invention, a maltodextrin mixture in which at least 80 percent of the maltodextrin species in the mixture have a DP greater than 5 is used, and in some such

embodiments, preferably at least 60 percent have a DP greater than 8. In another embodiment, a maltodextrin in which at least 80 percent of the maltodextrin species have a DP greater than 10 is used. In some embodiments of the invention, the DP profile of the maltodextrin is such that at least 75 percent of the maltodextrin species in the mixture have a DP greater than 5 and at least 40 percent of the species in the mixture have a DP greater than 10. The maltodextrins may include saccharide species having an odd DP value, and the profile may be partially defined by a saccharide species having a DP value of 1, for example, dextrose or sorbitol. The mixture further may include other saccharide species or other components. Such starting materials may be obtained conventionally, for example, by the partial hydrolysis of starch.

Suitable maltodextrins are sold under the trademark MALTRIN® by Grain Processing Corporation of Muscatine, Iowa. The MALTRIN® maltodextrins are mixtures of malto-oligosaccharides. Each MALTRIN® maltodextrin is characterized by a typical dextrose equivalent value (DE) and DP profile. Suitable MALTRIN maltodextrins that may be incorporated as borehole stability agents in accordance with the invention, include, for example, MALTRIN® M040, MALTRIN® M050, MALTRIN® M100, MALTRIN® M150, and MALTRIN® M180. Typical approximate DP profiles for the subject Maltrin maltodextrins are set forth in the following table (the DP profiles being approximate as indicated in the Table):

Typical DP profile (% dry solids basis)						
DP profile	M180	M150	M100	M050	M040	
DP>8	46.6 ±4%	54.7 ±4%	67.8 ±4%	90.6 ±4%	88.5 ±4%	
DP 8	3.9 ±2%	4.8 ±1.5%	4.5 ±1.5%	1.5 ±1%	2.0 ±1%	
DP 7	9.5 ±2%	9.1 ±1.5%	7.0 ±1.5%	1.5 ±1%	2.4 ±1%	
DP 6	11.4 ±2%	8.4 ±1.5%	6.1 ±1.5%	1.4 ±1%	1.8 ±1%	
DP 5	5.9 ±2%	4.7 ±1.5%	3.3 ±1.5%	1.3 ±1%	1.3 ±1%	
DP 4	6.4 ±2%	5.5 ±1.5%	3.7 ±1.5%	1.1 ±1%	1.4 ±1%	
DP 3	8.3 ±2%	6.7 ±1.5%	4.2 ±1.5%	1.0 ±1%	1.4 ±1%	
DP 2	6.2 ±2%	4.8 ±1%	2.5 ±1%	0.8* ±1%	0.9* ±1%	
DP 1	1.8 ±1.5%	1.3 ±1%	0.7* ±1%	0.8* ±1%	0.3* ±1%	
	DE** = 18	DE = 15	DE = 10	DE = 5	DE = 5	

* Minimum Value = 0%

** Dextrose Equivalent Value

Other suitable maltodextrins as may be known or discovered also may be considered useful in conjunction with the invention.

The maltodextrin may be present in any amount
5 effective to inhibit shale swelling. When the drilling fluid includes a maltodextrin borehole stability agent and does not include hemicellulose, the maltodextrin preferably is present in a total amount ranging from about 0.002 to about 0.2 lbs./gallon, more preferably about 0.01
10 to about 0.15 lbs./gallon by dry basis weight of the maltodextrin. In this embodiment of the invention, these amounts are irrespective of the amount of cellulose in the drilling fluid.

The borehole stability agent alternatively or
15 additionally may comprise a carboxyalkyl starch, preferably a carboxymethyl starch. Carboxymethyl starches are known in the art, and the preparation of such starches is described in Modified Starches: Properties and Uses (Wurzburg, O.B., Ed.) 1986, p. 187-88. When the drilling
20 fluid includes a carboxymethyl starch but does not include any other borehole stability agent, the carboxymethyl starch preferably is present in the drilling fluid in an amount ranging from about 0.002 to about 0.2 lbs./gallon, more preferably about 0.01 to about 0.15 lbs./gallon. In
25 this embodiment, these amounts are irrespective of the amount of cellulose in the composition. The carboxyalkyl starch may have a degree of substitution (DS) of any suitable value. Adequate results may be obtained when the starch has a DS of about 0.2.

30 The drilling fluid of the invention may incorporate a borehole stability agent that includes a maltodextrin, and hemicellulose in any combination of two or more of the foregoing. In such case, the total amount of the combined borehole stability agent present in the drilling fluid
35 preferably ranges from about 0.002 to about 0.2 lbs./gallon by dry basis weight, irrespective of the

amount of cellulose in the drilling fluid, with the maltodextrin, starch, and hemicellulose being present in any amount relative to one another. More generally, the borehole stability agent may be present in any amount
5 effective to inhibit shale swelling.

The drilling fluid further preferably includes a salt, preferably NaCl. Salts are believed to assist the alkyl glycoside and/or the borehole stability agent in inhibiting shale swelling. When sea water is used as the
10 liquid base, or when the bore formation includes salt water, salt will be present in the form of sodium chloride. Other salts that may be incorporated in the composition of the invention include potassium chloride, calcium chloride, sodium acetate, potassium acetate,
15 calcium acetate, and the like. The salt is preferably present in the drilling fluid in an amount ranging from about 0.15 to about 0.8 lbs./gallon by dry basis weight but, more generally, may be present in any amount effective to assist in inhibiting shale swelling.

20 The drilling fluid may include further additives as may be appropriate. Examples of additives that are known in the art include barite, and other weighting agents, bentonite, low-and-medium-yield clays, salt water clay, iron oxide, calcium carbonate, starch,
25 carboxymethylcellulose, acrylonitrile, gums, molecularly dehydrated phosphate, tannin compound, quebracho, lignins, lignosulfate, mica, sugar cane fibers, and granular materials. Generally, the drilling fluid may contain other ingredients such as weighting agents, viscosifiers,
30 fluid loss reducing additives, rheological modifying additives, emulsifiers, seepage loss control additives, lubricity additives, defoamers, pH control additives, dispersants, and so forth, all of such materials being
35 in such amounts as may be appropriate. It is generally contemplated that any other suitable additive as is known

or as may be discovered may be employed in connection with the invention.

The invention further encompasses a drilling fluid additive composition that includes an alkyl glycoside and a borehole stability agent that is selected from among a maltodextrin, a carboxyalkyl starch, hemicellulose, and mixtures of the foregoing. In accordance with this embodiment of the invention, the liquid base is not present, or is present in a smaller amount than is intended in the final drilling composition. The composition may be supplied to drillers, for example, to be used as an additive to seawater or brine in forming a drilling fluid in situ, or may be supplied to fabricators of drilling fluid to be blended with a liquid base. In accordance with this embodiment of the invention, the hemicellulose, starch, and/or maltodextrin preferably are present in an amount ranging from about 0.1% to about 5% by the dry basis weight of the alkyl glucoside. The composition may be dry or may be in liquid form, with the hemicellulose, starch, and maltodextrin being dissolved in a liquid. The composition of this embodiment of the invention may include other ingredients, such as salts or other additive, which other ingredient may be employed in such amounts as may be desired.

The invention also encompasses a drilling fluid that includes methyl glycoside or other alkyl glycoside and cellulose, the alkyl glycoside being present in at least an amount effective to inhibit shale swelling, and the cellulose being present in an amount of at least about 0.1% by weight of the alkyl glycoside. It is contemplated that cellulose may assist the alkyl glycoside in promoting borehole stability. Preferably, the cellulose is present in an amount of from about 0.1% to about 5% by weight of the alkyl glycoside. In this embodiment of the invention, the amount of cellulose in the drilling fluid is

irrespective of the amount of dry hemicellulose or maltodextrin in the drilling fluid.

The invention also encompasses a drilling apparatus. With reference to the Figure, the apparatus is shown generally at 10 and includes a drill string 11, the drill string 11 generally including a drive 12, a drill stem 14, and a drill bit 15 (the drive 12 is shown as a top drive, but other configurations, such as a rotary table, are possible). The drill stem 14 may include components such as drill collars, drill pipe and a kelly (not separately shown). The drill string 11 is fluidically connected to a source 16 of drilling fluid which comprises the drilling fluid of the invention. Generally, the source 16 will be suction tanks 17 that are fluidically coupled to mud pumps 18 and optionally a mud pit (not shown). The mud pump circulates fluid through the drill string 11, i.e., through and around the drill bit and/or through the annulus between the drill stem and the borehole. The apparatus generally may take any other conventional or otherwise suitable form and is not limited to the configuration shown in the Figure.

The invention also encompasses a process for drilling. The process includes the step of circulating the drilling fluid of the present invention through the drill string of a drilling apparatus during drilling operations. No special apparatus is contemplated by the process of the invention, but instead the process is contemplated to be useful in connection with any suitable drilling apparatus.

The following examples are provided to illustrate the present invention, but should not be construed as limiting in scope.

EXAMPLES

VOLCALY Clay bentonite tablets (American Colloid Company, Skokie, Illinois) were soaked in various drilling

fluids and observed over a period of time to simulate the effect of the drilling fluid on shale in a well bore. The stability of each bentonite pellet was evaluated according to the following scale:

- 5 1= unaltered
 2= hard, intact but loose on surface
 3= swollen, softening, still intact
 4= together, but no integrity
 5= dissolved

10 These evaluations were designed to evaluate the drilling fluids as against one another, rather than to directly evaluate efficiency in actual borehole conditions.

The drilling fluids were prepared using as alkyl glycosides MeG-365 (a 65% aqueous solution of methyl glucoside existing as a 2:1 ratio of α : β isomers), and a
 15 70% aqueous solution of methyl glucoside existing as a 1:1 ratio of α : β ratio) (designated hereunder as MeG-207). As borehole stability agents, MALTRIN® M040, M100, and M180 (maltodextrins available from Grain Processing Corporation
 20 of Muscatine, Iowa) and the soluble fraction resulting from alkaline treatment of corn hulls (designated hereunder as "HC") were used. As a control, drilling fluids were prepared using only water and using only MeG-365 or MeG-207, without the addition of hemicellulose or
 25 maltodextrin. All of the drilling fluids were prepared at an initial pH of 7 unless otherwise indicated.

Control

30 Drilling fluids were prepared with MeG-365 and MeG-207. The stability of the bentonite pellets in each fluid was evaluated. The stability of the pellets in pure water also was evaluated. The following results were obtained.

Drilling Fluid	1 hr.	2 hr.	4 hr.	8 hr.	24 hr.
H ₂ O	4	4.5	5	5	5
365	2	2.5	3	4.5	5
207	1	1	1.5	2	3

Drilling Fluid	1 hr.	2 hr.	4 hr.	20 hr.	30 hr.
365	2	2	3.5	4.5	5
207	1	1	1.5	2.5	3

Drilling Fluid	1 hr.	4 hr.	8 hr.	24 hr.	32 hr.	56 hr.
365	1.5	3	3.5	4.5	---	---
207	1	1.5	2	3.5	4	5

Drilling Fluid	1 hr.	2 hr.	4 hr.	8 hr.	24 hr.	48 hr.
365	1.5	2	3	3.5	4.5	---
207	1	1	1.5	1.5	3	---

5

The bentonite pellets were substantially unstable in water, and fared only somewhat better in the drilling fluids that included methyl glucoside and water but that did not include maltodextrin or hemicellulose.

10

Example 1

MeG + Maltodextrin

Drilling fluids were prepared using methyl glucoside
 5 and maltodextrin, and the bentonite stability test was
 repeated for each fluid. The following results were
 obtained. Maltodextrin percentages in these tables express
 weight percent maltodextrin by dry basis of methyl
 glucoside.

Drilling Fluid	1 hr.	2 hr.	4 hr.	8 hr.	24 hr.
365 + 5% M040	1	1	1.5	1.5	2
365 + 5% M100	1	1	1.5	1.5	2.5
365 + 5% M180	1.5	1.5	2	2	4

10

Drilling Fluid	1 hr.	2 hr.	4 hr.	20 hr.	30 hr.
365 + 1% M040	1.5	2	2.5	4	4
365 + 3% M040	1	1.5	1.5	2.5	3

Drilling Fluid	1 hr.	4 hr.	8 hr.	24 hr.
365 + 0.5% M100	1.5	2	3.5	4
365 + 1% M100	1	1.5	1.5	3.5

As set forth above, the bentonite pellets generally were
 more stable in the drilling fluids of Example 1 than in
 15 the control drilling fluids.

Example 2

MeG + Maltodextrin + NaCl

Drilling fluids were prepared using MeG,
 maltodextrin, and sodium chloride. The bentonite
 stability test was repeated for each fluid, and the
 following results were obtained. Sodium chloride
 percentages in these tables express weight percent sodium
 25 chloride by dry basis weight of methyl glucoside.

Drilling Fluid	1 hr.	2 hr.	4 hr.	8 hr.	24 hr.
365 + 5% M040 + 10% NaCl	1	1	1	1.5	2
365 + 5% M100 + 10% NaCl	1	1	1.5	1.5	2
365 + 5% M180 + 10% NaCl	1	1.5	1.5	2	4

Drilling Fluid	1 hr.	2 hr.	4 hr.	20 hr.	30 hr.
365 + 1% M040 + 5% NaCl	1.5	1.5	1.5	2	3
365 + 3% M100 + 5% NaCl	1	1	1.5	2	3

5

Drilling Fluid	1 hr.	4 hr.	8 hr.	24 hr.
365 + 0.5% M040 + 2% NaCl	1.5	1.5	2.5	3.5
365 + 1% M100 + 2% NaCl	1	1.5	1.5	3
365 + 0.5% M100 + 5% NaCl	1.5	2	2	3.5
365 + 1% M100 + 5% NaCl	1	1.5	1.5	3.5

As seen, the addition of sodium chloride to the drilling fluid rendered the fluid retention less aggressive toward the bentonite pellets.

10

Example 3

MeG + HC

Drilling fluids were prepared using MeG and the hemicellulose fraction of alkaline treated corn hulls. The bentonite stability tests were repeated, and the following examples were obtained. Hemicellulose percentages in these tables are expressed as weight percent dry hemicellulose provided in the HC solution by dry basis MeG.

15

Drilling Fluid	1 hr.	2 hr.	4 hr.	8 hr.
365 + 0.6% hemicellulose	1	1	1	1.5
365 + 0.6% hemicellulose (solution diluted to 50%)	2.5	3.5	4	4.5

Drilling Fluid	1 hr.	2 hr.	4 hr.	20 hr.	30 hr.
365 + 1% hemicellulose	1	1	1	2	2.5

Drilling Fluid	1 hr.	2 hr.	4 hr.	8 hr.	24 hr.	48 hr.
207 + 0.5% hemicellulose	1	1	1	1	1.5	1.5
365 + 0.6% hemicellulose	1	1	1	1.5	---	---

As seen, the bentonite pellets were substantially
 5 more stable in the drilling fluids prepared using MeG and
 hemicellulose than in the drilling fluids prepared using
 only MeG.

Example 4

MeG + HC + NaCl

10

Drilling fluids were prepared using MeG, the
 hemicellulose and sodium chloride. The bentonite
 stability tests were repeated and the following results
 were obtained.

Drilling Fluid	1 hr.	2 hr.	4 hr.	20 hr.	30 hr.
365 + 1% hemicellulose + 5% NaCl	1	1	1	1.5	2

15

Drilling Fluid	1 hr.	4 hr.	8 hr.	24 hr.	32 hr.	56 hr.
365 + 0.5% hemicellulose + 2% NaCl	1	1.5	2	2	2.5	3
365 + 1% hemicellulose + 5% NaCl	1	1	1.5	1.5	2	2.5

20

As seen, the bentonite pellets were substantially more
 stable in the drilling fluids thus prepared than in the
 control drilling fluids. Addition of salt to the drilling

fluid reduced the aggressiveness of the fluid towards the bentonite pellets.

Comparative Examples 1-11

- 5 Drilling fluids were prepared using MeG and other organic additives in accordance with the following table. The bentonite stability test was repeated for each drilling fluid, giving the following results:

Drilling Fluid	1 hr.	2 hr.	4 hr.	8 hr.	24 hr.
365 + 10% NaCl*	2	2.5	3.5	4	5
365 at pH 10	2.5	3	3.5	4	5
365 + 5% hydroxy-propyl starch*	2	2.5	3	3	---
365 + 2% corn starch*	2	2.5	2.5	4	---
365 + 2% solubilized starch*	1.5	2	2.5	3.5	4.5
365 + 2% polyethylene oxide*	2	2.5	3.5	4	4.5
365 + 2% ethoxylated starch*	1.5	2.5	3.5	4	4.5
365 + 2% acid modified starch*	1.5	2	3	4	4.5
365 + 2% cationic starch*	1.5	2	3.5	4	4.5
365 + 2% gum arabic*	1.5	2	3	4.5	---
365 + 2% guar gum*	1	1	1.5	2	---

10 *dry basis MeG.

As seen, the bentonite pellets generally were not as stable in the drilling fluids of the comparative examples as in the drilling fluids of the invention. These results demonstrate the surprising benefits of using maltodextrin and/or hemicellulose as a borehole stability agent as compared with other organic species.

Example 5
Water Activity

10

The water activity, or relative humidity that exists in the space above the drilling fluid in an enclosed container, was evaluated for each of the drilling fluids of the invention and for control drilling fluids. It is believed that the stability of wellbore formations in a drilling fluid generally improves as the water activity value of the drilling fluids decreases.

15

The following results were obtained:

Drilling Fluid (Control)	Water activity @ 25°C
Pure H ₂ O	1.01 (as measured)
MeG-365	0.864
MeG-207	0.789
MeG-207 diluted to 65% solids	0.851

20

Drilling Fluid (Invention)	Water Activity @ 25° C
MeG-207 + 0.5% hemicellulose ⁽¹⁾	0.780
MeG-365 + 0.5% hemicellulose ⁽¹⁾	0.889
MeG-365 + 1% hemicellulose ⁽¹⁾	0.836
MeG-365 + 2% hemicellulose ⁽¹⁾	0.816
MeG-365 + 0.5% hemicellulose ⁽¹⁾ + 2% NaCl ⁽²⁾	0.810
MeG-365 + 0.5% hemicellulose ⁽¹⁾ + 5% NaCl ⁽²⁾	0.727
MeG-365 + 1% hemicellulose ⁽¹⁾ + 5% NaCl ⁽²⁾	0.768
MeG-365 + 0.5% Maltodextrin ⁽²⁾	0.844
MeG-365 + 1% Maltodextrin ⁽²⁾	0.855
MeG-365 + 2% Maltodextrin ⁽²⁾	0.845
MeG-365 + 0.5% Maltodextrin ⁽²⁾ + 2% NaCl ⁽²⁾	0.820
MeG-365 + 0.5% Maltodextrin ⁽²⁾ + 5% NaCl ⁽²⁾	0.759
MeG-365 + 1% Maltodextrin ⁽²⁾ + 2% NaCl ⁽²⁾	0.811
MeG-365 + 1% Maltodextrin ⁽²⁾ + 5% NaCl ⁽²⁾	0.756

(1) by net basis, on dry MeG basis.

(2) On dry basis MeG.

Example 6

5 A drilling fluid comprising MeG-365, 5% MALTRIN® M040 (on dry basis MeG), and 0.6% hemicellulose (on dry basis hemicellulose) is prepared.

Example 7

10 A drilling composition comprising 50% polyglycerine, 20% water, 1% hemicellulose (dry basis), and 29% MeG (2:1

$\alpha:\beta$) (dry basis) is prepared. The MeG is obtained from MeG-365.

Example 8

5 A drilling composition comprising 50% polyglycerine, 20% water, 1% maltodextrin (MALTRIN® M180) (dry basis), and 29% MeG (2:1 $\alpha:\beta$) (dry basis) is prepared. The MeG is obtained from MeG-360.

10

Example 9

A composition comprising 65% MeG and 2.5% hemicellulose is prepared (balance water). The composition is suitable for addition to seawater to form a drilling fluid.

15

Example 10

A drilling fluid comprising the following ingredients is prepared:

20

350 lbs.	Fresh Water
20 lbs.	Bentonite
4 lbs.	Lime
3 lbs.	Polysaccharide deflocculant
0.75 lb.	KOH
1-2 lbs.	Drilling Starch
0.25 lb.	Lignite
10-30 lbs.	MeG (2:1 $\alpha:\beta$)
---	Hemicellulose

Example 11

A composition comprising the following ingredients is prepared:

350 lbs.	Fresh Water
20 lbs.	Bentonite
4 lbs.	Lime
3 lbs.	Polysaccharide Deflocculant
0.75 lb.	KOH
1-2 lbs.	Drilling Starch
0.25 lb.	Lignite
10-30 lbs.	MeG (2:1 α : β)
	Maltodextrin (MALTRIN® M040)

5

Example 12

A composition comprising the following ingredients is prepared:

250 lbs.	Sea Water
11 lbs.	KCl
100 lbs.	Bentonite
0.50 lb.	NaOH
1-4 lbs.	Drilling Starch
10-30 lbs.	MeG (2:1 α : β)
	Hemicellulose

10

Example 13

A composition comprising the following ingredients is prepared:

250 lbs.	Sea Water
11 lbs.	KCl
100 lbs.	Bentonite
0.50 lb.	NaOH
1-4 lbs.	Drilling Starch
10-30 lbs.	MeG (2:1 α : β)
	Maltodextrin

Example 14

5 Corn hulls from a corn wet milling operation are wet screened through a U.S. No. 6 screen at about 50° C using sufficient water to substantially remove the fine fiber, most of the starch and some of the protein and lipid material present. The hulls remaining on the screen are then slurried in water and the pH of the slurry is
 10 adjusted with lime to pH 6.5 and treated at 79 °C for 1 hour with a *B. subtilis* alpha-amylase at a dosage of about 3 liquefons/g of hull solids. The hulls are filtered, washed and dried to a moisture range of 5 to 10 percent in a forced air oven at 70° C.

15 Fifty-two grams (50.6 g d.b.) of the hulls are slurried in 1000 ml of 69 percent aqueous ethanol (v/v) containing 5 g of reagent grade NaOH, and the slurry is heated in a Parr model 4522 pressure reactor at 100° C for 3 hours. The reaction mixture, at a temperature of about
 20 50° C, is then filtered through a Buchner funnel using Whatman No. 3 filter paper.

The filter cake is then extracted by refluxing at about 82 °C with 1000 ml of 69 percent aqueous ethanol (v/v) for one hour, and the mixture is filtered at a
 25 temperature of about 50 °C through a Buchner funnel using Whatman No. 3 paper. The filter cake is next slurried in 1000 ml of 69 percent aqueous ethanol (v/v), and the

slurry is adjusted with diluted HCl to pH 2 and is filtered as above. The filtrate is next combined with the filtrates from the two previous filtrations. The combined filtrates then are adjusted to pH 2 with HCl, and
5 evaporated to dryness. The residue is dried in a vacuum oven at 70° C.

To extract the hemicellulose, the filter cake from the above procedure is slurried in 1000 ml of deionized water, held at room temperature for about two hours, and
10 filtered through a coarse sintered glass funnel. This procedure is repeated a second time. The filtrates from these two extractions are combined and concentrated to about 10 percent solids by evaporation of the water on a vacuum rotary evaporator at a temperature of 40° C and a
15 vacuum of about 20 inches of mercury. The concentrated hemicellulose solution is then dried on a drum drier having a surface temperature of 130° C, and the dried hemicellulose is ground in a Waring blender.

The hemicellulose is added to 10 kg MeG-365 in an amount of 2.5% hemicellulose (on dry basis MeG) to form a
20 drilling fluid.

Example 15

25 Various drilling fluids were prepared as set forth in detail below. The ability of each fluid to stabilize shale was evaluated by measuring the amount of time required for a bentonite clay pellet to break down (as
30 was determined when the pellet had reached or passed "4" on the scale discussed in the earlier Examples). For control purposes, drilling fluids that included methyl glycoside but that did not include a borehole stability agent were evaluated. The compositions of the drilling
35 fluids that were prepared and the results of the stability tests are set forth below.

Drilling Fluid	Time to pellet breakdown
365	<1 day
207	<2 days

Drilling Fluid	Time to pellet breakdown
365 + 4% M040 + 4% KOH	7 days
365 + 4% CMS + 4% KOH	>25 days
365 + 2% CMS + 4% KOH	5 days
365 + 1% CMS + 4% KOH	4 days
365 + 2% CMS + 2% KOH	4 days
365 + 1% CMS + 2% KOH	3 days

CMS is carboxymethyl starch having a DS of 0.2

5 It is thus seen that both the maltodextrin and the carboxymethyl starch tested functioned as borehole stability agents.

Thus, the foregoing general objects have been satisfied. The invention provides a drilling fluid that is suitable for use in connection with borehole drilling. The invention further provides a drilling apparatus and
10 method that incorporate the improved drilling fluid.

While particular embodiments of the invention have been shown, it will be understood that the invention is not limited thereto since modifications may be made by those skilled in the art, particularly in light of the
15 foregoing teachings. It is therefore contemplated that the invention encompasses the subject matter of the following claims and equivalents thereof. All references cited herein are hereby incorporated by reference in their entireties.

20

WHAT IS CLAIMED IS:

1. A drilling fluid comprising:
 - a liquid base selected from the group consisting of water, water-miscible liquids, and mixtures thereof;
 - 5 an alkyl glycoside, said alkyl glycoside being present in at least an amount effective to inhibit shale swelling and being selected from among the α -form, the β -form, and mixtures thereof, said alkyl glycoside selected from among the methyl, ethyl, propyl, and butyl
 - 10 glycosides of glucose, maltose, maltotriose, and maltotetraose; and
 - a borehole stability agent selected from the group consisting of a maltodextrin, a carboxyalkyl starch, hemicellulose, and mixtures thereof, said borehole
 - 15 stability agent being present in at least an amount effective to inhibit shale swelling.
2. A composition according to claim 1, wherein said liquid base comprises water.
- 20 3. A composition according to claim 1, wherein said liquid base includes polyglycerine.
4. A composition according to claim 3, wherein
- 25 said liquid base includes polyglycerine and water.
5. A composition according to claim 1, said alkyl glycoside comprising methyl glucoside.
- 30 6. A composition according to claim 1, said alkyl glycoside being present in an amount ranging from about 2 to about 4 lbs./gallon by dry basis weight.
7. A composition according to claim 6, said methyl
- 35 glucoside being present in the amount of about 3

lbs./gallon by dry basis weight and comprising a 2:1 α : β mixture of methyl glucoside.

5 8. A composition according to claim 6, said methyl glucoside being present in the amount of about 3 lbs./gallon by dry basis weight and comprising a 1:1 α : β mixture of methyl glucoside.

10 9. A composition according to claim 1, said borehole stability agent comprising hemicellulose.

15 10. A composition according to claim 9, wherein hemicellulose is present in said drilling fluid in an amount ranging from about 0.002 to about 0.2 lbs./gallon by dry basis weight.

20 11. A composition according to claim 9, wherein said hemicellulose comprises a hemicellulose fraction obtained via alkali hydrolysis of corn hulls.

12. A composition according to claim 1, said borehole stability agent comprising a maltodextrin.

25 13. A composition according to claim 12, wherein said maltodextrin is present in an amount ranging from about 0.002 to about 0.2 lbs./gallon by dry basis weight.

30 14. A composition according to claim 1, said borehole stability agent comprising a mixture of maltodextrin and hemicellulose.

35 15. A composition according to claim 14, wherein said borehole stability agent is present in a total amount ranging from about 0.002 to about 0.2 lbs./gallon by dry basis weight.

16. A composition according to claim 1, said borehole stability agent comprising a carboxymethyl starch.

5 17. A composition according to claim 16, said carboxymethyl starch having a DS of about 0.2.

10 18. A composition according to claim 16, said borehole stability agent comprising a mixture of carboxymethyl starch and maltodextrin.

15 19. A composition according to claim 16, said borehole stability agent comprising a mixture of carboxymethyl starch and hemicellulose

20. A drilling apparatus comprising:
a drill string;

20 at least one pump for circulating a drilling fluid through at least a portion of said drill string, said pump being fluidically connected to a source of drilling fluid, said drilling fluid comprising:

a liquid base selected from the group consisting of water, water-miscible liquids, and mixtures thereof;

25 an alkyl glycoside, said alkyl glycoside being present in at least an amount effective to inhibit shale swelling and being selected from among the α -form, the β -form, and mixtures thereof, said alkyl glycoside selected from among the methyl, ethyl, propyl, and butyl glycosides; and

30 a borehole stability agent selected from the group consisting of a maltodextrin, a carboxyalkyl starch, hemicellulose, and mixtures thereof, said borehole stability agent being present in at least
35 an amount effective to inhibit shale swelling.

21. A drilling process comprising the steps of:
cutting a borehole into the earth using a drill
string; and

circulating a drilling fluid through at least a
5 portion of said drill string, said drilling fluid
comprising:

a liquid base selected from the group
consisting of water, water-miscible liquids, and
mixtures thereof;

10 an alkyl glycoside, said alkyl glucoside being
present in at least an amount effective to inhibit
shale swelling and being selected from among the α -
form, the β -form, and mixtures thereof, said alkyl
glycoside selected from among the methyl, ethyl,
15 propyl, and butyl glycosides; and

a borehole stability agent selected from the
group consisting of a maltodextrin, a carboxyalkyl
starch, hemicellulose, and mixtures thereof, said
borehole stability agent being present in at least
20 an amount effective to inhibit shale swelling.

22. A composition comprising:

an alkyl glycoside selected from among the α -form,
the β -form, and mixtures thereof, said alkyl glycoside
25 selected from among the methyl, ethyl, propyl, and butyl
glucosides of glucose, maltose, maltotriose, and
maltotetraose; and

a borehole stability agent, said borehole stability
agent being selected from the group consisting of a
30 maltodextrin, a carboxyalkyl starch, hemicellulose, and
mixtures thereof, said borehole stability agent being
present in an amount ranging from about 0.1% to about 5%
by dry basis weight of said alkyl glucoside.

35 23. A drilling fluid comprising:

a liquid base selected from the group consisting of water, water-miscible liquids, and mixtures thereof;

an alkyl glycoside, said alkyl glycoside being present in at least an amount effective to inhibit shale swelling and being selected from among the α -form, the β -form, and mixtures thereof, said alkyl glycoside selected from among the methyl, ethyl, propyl, and butyl glycosides of glucose, maltose, maltotriose, and maltotetraose; and

cellulose, said cellulose being present in an amount of at least 0.1% by weight of said alkyl glycoside.

24. A drilling fluid according to claim 23, wherein said cellulose is present in an amount ranging from about 0.1% to about 5% by weight of said alkyl glycoside.

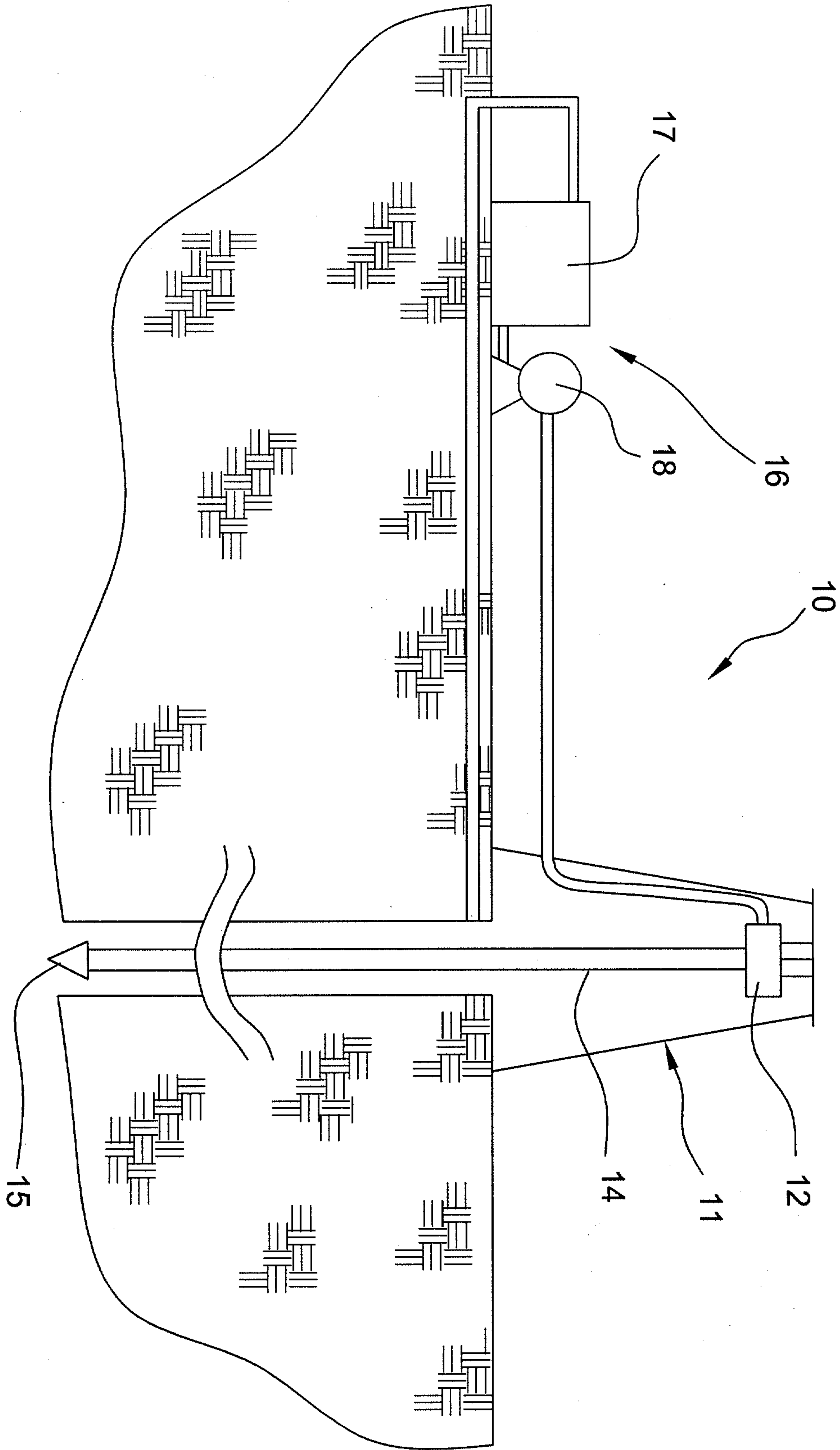

Figure 1

Marks & Clerk

