



(51) International Patent Classification:  
*B65D 90/18* (2006.01)

(21) International Application Number:  
PCT/NO2013/050209

(22) International Filing Date:  
29 November 2013 (29.11.2013)

(25) Filing Language: English

(26) Publication Language: English

(30) Priority Data:  
20121459 5 December 2012 (05.12.2012) NO  
61/733,749 5 December 2012 (05.12.2012) US

(71) Applicant: JACK-PACK AS [NO/NO]; Postboks 415, N-4304 Sandnes (NO).

(72) Inventor: FJETLAND, Geir Tore; Gravarskroken 3, N-4327 Sandnes (NO).

(74) Agent: HÅMSØ PATENTBYRÅ ANS; Postboks 171, N-4302 Sandnes (NO).

(81) Designated States (unless otherwise indicated, for every kind of national protection available): AE, AG, AL, AM,

AO, AT, AU, AZ, BA, BB, BG, BH, BN, BR, BW, BY, BZ, CA, CH, CL, CN, CO, CR, CU, CZ, DE, DK, DM, DO, DZ, EC, EE, EG, ES, FI, GB, GD, GE, GH, GM, GT, HN, HR, HU, ID, IL, IN, IR, IS, JP, KE, KG, KN, KP, KR, KZ, LA, LC, LK, LR, LS, LT, LU, LY, MA, MD, ME, MG, MK, MN, MW, MX, MY, MZ, NA, NG, NI, NO, NZ, OM, PA, PE, PG, PH, PL, PT, QA, RO, RS, RU, RW, SA, SC, SD, SE, SG, SK, SL, SM, ST, SV, SY, TH, TJ, TM, TN, TR, TT, TZ, UA, UG, US, UZ, VC, VN, ZA, ZM, ZW.

(84) Designated States (unless otherwise indicated, for every kind of regional protection available): ARIPO (BW, GH, GM, KE, LR, LS, MW, MZ, NA, RW, SD, SL, SZ, TZ, UG, ZM, ZW), Eurasian (AM, AZ, BY, KG, KZ, RU, TJ, TM), European (AL, AT, BE, BG, CH, CY, CZ, DE, DK, EE, ES, FI, FR, GB, GR, HR, HU, IE, IS, IT, LT, LU, LV, MC, MK, MT, NL, NO, PL, PT, RO, RS, SE, SI, SK, SM, TR), OAPI (BF, BJ, CF, CG, CL, CM, GA, GN, GQ, GW, KM, ML, MR, NE, SN, TD, TG).

Published:

— with international search report (Art. 21(3))

(54) Title: LIFTING DEVICE FOR CONTAINER AND METHOD FOR USING THE SAME

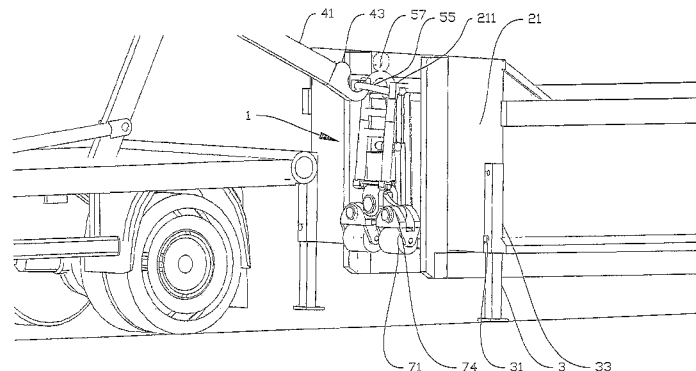

Fig. 3

(57) Abstract: A lifting device (1) for a container (2) is described, the lifting device (1) being arranged to be attached at one end (21) of the container (2), and the lifting device (1) comprising: - a tow bar (5) being adjustable between an erect position and an unfolded position; - an undercarriage (7) connected to the tow bar and provided with one or more wheels (71), the undercarriage (7) being adjustable between at least a raised position and a lowered position, and the undercarriage (7) being arranged, in the lowered position, to carry at least part of the weight of the container (2), characterized by the undercarriage (7) being arranged to be adjusted from the raised position into the lowered position by means of manual force and/or gravity, the undercarriage (7) being arranged to be adjusted from the raised position to the lowered position when the end (21) of the container (2) has been lifted above the supporting surface. A method of using a lifting device (1) for a container (2) is described as well.

## LIFTING DEVICE FOR CONTAINER AND METHOD FOR USING THE SAME

A lifting device for a container is described, the lifting device being arranged to be attached at an end of the container, and the lifting device including a tow bar which is adjustable between an erect position and an unfolded position and an undercarriage  
5 connected to the tow bar and provided with one or more wheels, the undercarriage being adjustable between at least a raised position and a lowered position, and the undercarriage being arranged, in the lowered position, to carry part of the weight of the container. A method of using a lifting device for a container is described as well.

It is known that heavy transport equipment, such as a hook-lift truck, is provided with  
10 the necessary equipment and sufficient power to be able to lift and move a heavy container. As a container is rented, the driver of a hook-lift truck will usually place the container in a given location at a construction site, and leave it there. The container is picked up when it is full or as agreed. The drawback of this arrangement is that the container, as it is being filled up, becomes too heavy to be moved by smaller construction-site equipment such as tractors, forklift trucks or small excavators. The position  
15 of the container is therefore locked to the place in which the driver of the hook-lift truck put it down in the first place. Often, said driver will not be acquainted with the construction site, and the position of the container could therefore be unfavourable to the person or persons who are going to use the container or to others working in the  
20 same area. Generally, hook-lift trucks are also so large that the ability to navigate is restricted to open areas and relatively broad roads. After a container has been filled, completely or partially, it may be desirable to remove it or change its location within a construction site. This will not be possible without having to call in a hook-lift truck or the like, as mentioned above, and it will often lead to an unnecessarily long wait and  
25 extra cost to have the container moved or removed.

The patent document WO 2012/138229, filed by the present applicant, discloses a lifting device for a container, the lifting device including an actuator arranged to move an undercarriage of the lifting device down into engagement with the supporting sur-

face so that an end of the container is lifted above the supporting surface. This solution requires that the actuator should have hydraulic, pneumatic or electrical power available to lift the container.

The invention has for its object to remedy or reduce at least one of the drawbacks of the prior art or at least provide a useful alternative to the prior art.

The object is achieved through features which are specified in the description below and in the claims that follow.

In the present application, the term "container" is meant in a wide sense, so that the term includes all types of containers for the transport and temporary storage of goods, in both solid and liquid forms. It may be, for example, but is not limited to, different types of transport containers, hook-lift containers and dump bodies of different sizes and geometries. It is an advantage if a container with a lifting device attached to it, as described in what follows, is provided with one or more wheels at an end of the container opposite an end to which the lifting device is attached. Together with a lifting device in accordance with the invention, this will make it possible for a heavy, fully loaded transport container to be moved locally within a construction site by, for example, but not limited to, a tractor or a small construction-site engine.

The present invention provides a lifting device with an adjustable tow bar for a container, in which an undercarriage of the lifting device can be adjusted into a lowered position and locked in the lowered position while the end of the container, at which the lifting device is placed, is lifted above the supporting surface. Thus, the invention provides an alternative and simplified version of the above-mentioned WO publication, which will function without a hydraulic, electrical or pneumatic power supply to the lifting device.

In a first aspect, the invention relates to a lifting device for a container, the lifting device being arranged to be attached at an end of the container, and the lifting device comprising:

- a tow bar being adjustable between an erect position and an unfolded position;
- an undercarriage connected to the tow bar and provided with one or more wheels, the undercarriage being adjustable between at least a raised position and a lowered position, and the undercarriage being arranged, in the lowered position, to carry part of the weight of the container, characterized by the undercarriage being arranged to be brought from the raised position into the lowered position by means of manual force and/or gravity, the undercarriage being arranged to be brought from the raised

position to the lowered position when the end of the container has been lifted above the supporting surface.

On its side facing away from the container, the tow bar may be provided with a hook-connection element, so that the tow bar may constitute a connection point for a hook-  
5 lift truck which is to put down or pick up a container with a lifting device in accordance with the invention.

In one embodiment, the lifting device may include a sliding rail arranged to be locked at least in an upper position and in a lower position corresponding to, respectively, the raised position and the lowered position of the undercarriage. The sliding rail may be  
10 connected to the undercarriage of the lifting device, either directly or indirectly via various connecting parts.

In its erect position, the tow bar may be arranged to be locked to the container. The locking may be carried out by the tow bar being formed with a transverse bar complementarily fitting into locking dogs on the container.

15 The tow bar may further be arranged to be released from the container when the undercarriage is moved into its lowered position, by the transverse bar of the tow bar being released from the locking dogs of the container.

In one embodiment, the tow bar of the lifting device may be telescopic so that the length of the tow bar is adjustable. An advantage of this is that the undercarriage of the lifting device, which is connected to the tow bar, can be adjusted into its lowered  
20 position at the same time as the tow bar is being extended, so that the tow bar may still be locked to the locking dogs of the container by means of the transverse bar. In an embodiment like that, the container may be operated without support legs or the like for holding an end of the container while the undercarriage is being adjusted into  
25 its lowered position.

In a second aspect, the invention relates to a method of using a lifting device for a container, the lifting device being provided with an undercarriage, and the method including the step of attaching the lifting device to an end of the container, the method being characterized by further including the following steps:

- 30
- lifting the end of the container from the supporting surface into a lifted position;
  - lowering the undercarriage from a raised position into a lowered position by means of manual force and/or gravity;
  - locking the undercarriage in the lowered position; and
  - partially lowering the container from its lifted position so that at least part of the

weight of the container is resting on the undercarriage.

The step of lifting an end of the container up from the supporting surface into a lifted position may include lifting the container with the aid of a hook-lift truck.

5 Further, the step of lowering the undercarriage from a raised position into a lowered position may further include extending the tow bar, which is telescopic.

As an alternative or in addition, after the step of lifting an end of the container, the method may include adjusting one or more support legs of the container into a lowered position, wherein the support legs in the lowered position are arranged to carry at least part of the weight of the container. The support legs may be lowered when a  
10 hook-lift truck is about to put the container down, so that the support legs may carry part of the weight of the container while the undercarriage is being adjusted into its lowered position.

The method may further include unfolding the tow bar from an erect position into an unfolded position; and

15 - connecting the tow bar to a vehicle, whereby the container can be moved by the vehicle, the tow bar possibly being provided with a transverse bar and an eye hook.

In what follows, examples of preferred embodiments are described, which are visualized in the accompanying drawings, in which:

20 Figure 1 shows, in a perspective view, a container including a lifting device in accordance with the invention;

Figure 2 shows, in a side view and on a smaller scale, a hook-lift truck and a container including a lifting device in accordance with the invention;

25 Figure 3 shows, in a perspective view and on a somewhat larger scale than figure 2, parts of a hook-lift truck and a container including a lifting device in accordance with the invention;

Figures 4-5 show, in front views and on a somewhat larger scale than figure 1, a container including a lifting device in accordance with the invention;

Figure 6 shows, in a perspective view and on the same scale as figures 4 and 5, a container including a lifting device in accordance with the invention;

Figures 7-10 show, in perspective views and on larger scales, various details of a lifting device in accordance with the invention; and

Figure 11 shows, in a view an angle from above and on a smaller scale, part of an alternative embodiment of a lifting device in accordance with the invention.

In what follows, the reference numeral 1 indicates a lifting device in accordance with the invention. Like reference numerals indicate like or corresponding elements.

Figure 1 shows a container 2 provided with a lifting device 1 in accordance with the invention. The lifting device 1 is attached at an end face 21 of the container 2. The lifting device 1 includes a tow bar 5, the tow bar 5 being provided, on its side facing away from the container 2, with a hook-connection element 55. The tow bar 5 is further attached to an undercarriage 7 of the lifting device 1. The tow bar 5, which is shown in an erect position in the figure, is arranged to be rotated between the erect position and an unfolded position, see figure 6, the tow bar 5 being rotatably connected to the undercarriage 7 around a substantially horizontal rotational axis 781, see figure 8, parallel to the end face 21 of the container 2. The undercarriage 7 includes a connecting part 72 which is rotatably connected to an intermediate piece 73 around a first rotational axis 721. The intermediate piece 73 is further connected to two wheel brackets 74 with wheels 71 around second rotational axes 731. Both the first rotational axis 721 and the second rotational axes 731 are substantially horizontal normal to the end face 21 of the container 2. The undercarriage 7 further includes a sleeve 79 to which the connecting part 72 is rotatably connected around a substantially vertical rotational axis 791, see figure 8.

At opposite sides of the end face 21, the container 2 is provided with support legs 3. The support legs 3, which are shown in a raised position in figure 1, are arranged to be adjusted into a lowered position, see figures 3-5. Locking bolts 31 complementarily fit bolt holes 35 in a rectangular frame 33 and bolt holes, not shown, in the support legs 3. By pulling the locking bolts 31 out of upper bolt holes 35 of the rectangular frames 33, the support legs 3 are released, moving/gliding in the rectangular frames 33. The locking bolts 31 may then be inserted into lower bolt holes 35 in the rectangular frames 33, the lower bolt holes 35 now corresponding with the bolt holes, not shown, in the support legs 3, so that the support legs 3 are locked in a lowered position.

In figure 2, a prior-art hook-lift truck 4 is shown as it is about to put down a container

2 with a lifting device 1 in accordance with the invention. A lifting arm 41 is provided with a hook 43, see figure 3, to which the container 2 is attached by means of the hook-connection element 55 of the tow bar 5.

Further details of the lifting arm 41 with the hook 43 and a portion of the container 2 are shown in figure 3. The lifting arm 41 is holding the container 2 with the lifting device 1 in a raised position while the support legs 3 have been adjusted into the lowered position. In the lowered position, the support legs 3 are arranged to carry at least part of the weight of the container 2. The lifting arm 41 with the hook 43 may then be released from the hook-connection element 55, the weight of the container now resting on the support legs 3 and rear wheels 23 of the container 2.

In figure 4, the container 2 is shown after it has been put down on the ground by the hook-lift truck 4. The support legs 3 and rear wheels 23 carry the weight of the container 2, whereas the undercarriage 7 of the lifting device 1 is still in a raised position.

The undercarriage 7 of the lifting device 1 is arranged to be adjusted between a raised position, as shown in figures 1-4, and a lowered position, as shown in figures 5-6. In figure 5, the weight of the container 2 is still resting on the support legs 3 and rear wheels 23 even though the undercarriage 7 has been adjusted into a lowered position. To move the support legs 3 back into the raised position, the hook-lift truck 4 may again lift the end 21 of the container 2 slightly up from the supporting surface so that there is no weight resting on the support legs 3 as these are being displaced. The container 2 is then put down on the supporting surface so that its weight is now resting on the wheels 71 of the undercarriage and on the rear wheels 23. The displacement of the undercarriage 7 of the lifting device 1 between the raised position and the lowered position will be explained in more detail below with reference to figures 6 and 10.

In figure 6, the container 2 is shown after the support legs 3 have been moved back into the raised position, as described above, so that the weight of the container 2 is now resting on the wheels 71 of the undercarriage 7 and on the rear wheels 23. Further, the tow bar 5 has been unfolded into its unfolded position so that the container 2 can be moved by a vehicle, not shown, being connected to the eye hook 57 or transverse bar 59 of the tow bar 5, see figure 9. The transverse bar 59 of the tow bar 5 is also arranged to lock the tow bar to the container 2 in the erect position of the tow bar 5, as the end face 21 of the container 2 is provided with a set of locking dogs 211. Parts of a displacing device 9 of the lifting device 1 are shown in figure 6 as well. The displacing device 9 includes a frame 91 in which a sliding rail 93, see figure 10, is slidably positioned. The displacing device 9 further includes a locking bolt 95 which is ar-

ranged to lock the sliding rail 93 in an upper position and in a lower position by means of, respectively, upper lock mandrels 97 and lower lock mandrels 99 on the frame 91 and a lock mandrel 98, see figure 10, on the sliding rail 93. The sliding rail 93 is attached to the sleeve 79, see figure 8, which is further connected to the undercarriage 7 of the lifting device.

In figure 7, part of the undercarriage 7 of the lifting device 1 is shown in an exploded drawing. The coupling part 72 is shown at a distance from the intermediate piece 73 and the wheels 71 with the wheel brackets 74. The coupling part 72 and the intermediate piece 73 and the intermediate piece 73 and the wheel brackets 74 are rotatable relative to each other around an axle 722 and axles 732, respectively. The wheels 71 are further provided with journals complementarily fitting attachment holes 741 in the wheel brackets 74.

In figure 8, the undercarriage 7 is shown assembled and placed at a distance from the sleeve 79. The coupling part 72 is provided with a pin 76 complementarily fitting into the sleeve 79, whereby the undercarriage 7 may be rotated relative to the sleeve 79 around a substantially vertical rotational axis 791. The coupling part 72 is further provided with journals 78 to which the tow bar 5 is arranged to be attached by means of attachment holes 56, see figure 9, and be rotated around the above-mentioned rotational axis 781.

In figure 9, the tow bar 5 is shown in an exploded drawing, in which a movable, U-shaped telescopic part 51 of the tow bar 5 is separate from a fixed H-shaped part 53 of the tow bar, which, in a position of application, is rotatably connected to the undercarriage 7 of the lifting device 1 around the rotational axis 781. The length of the tow bar 5 can be adjusted by the telescopic part 51 being moved relative to the fixed part 53 and secured by means of securing means, not shown, in a desired position. The securing means may be, for example, bolts not shown, complementarily fitting bolt holes. Attachment holes 56 at the bottom of the tow bar 5 are used for the attachment of the tow bar 5 to the journals 78 on the coupling part 72 of the undercarriage 7.

In figure 10, the displacing device 9 of the lifting device 1 is shown in more detail. The displacing device 9 has the effect of making the undercarriage 7 displaceable from a raised position into a lowered position, the displacing device 9 being fixed to the sleeve 79 of the undercarriage 7. The sliding rail 93 is slidably positioned inside the frame 91. The locking bolt 95 complementarily fits into upper lock mandrels 97 and lower lock mandrels 99 as well as into the lock mandrel 98 on the sliding rail 93,

whereby the sliding rail 93 can be locked in an upper position and a lower position corresponding to the raised position and the lowered position, respectively, of the undercarriage 7.

In figure 11, another embodiment of the lifting device 1 is shown, in which the sliding  
5 rail 93 is provided with wheels 931 which reduce the friction of the sliding rail 93 inside the frame 91.

## C l a i m s

1. A lifting device (1) for a container (2), the lifting device (1) being arranged to be attached at one end (21) of the container (2), and the lifting device (1) comprising:
  - 5 - a tow bar (5) being adjustable between an erect position and an unfolded position;
  - an undercarriage (7) connected to the tow bar (5) and provided with one or more wheels (71), the undercarriage (7) being adjustable between at least a raised position and a lowered position, and the undercarriage (7) being arranged, in the lowered position, to carry at least part of the weight of the container (2), c h a r a c t e r i z e d i n that the undercarriage (7) is arranged to be brought from the raised position into the lowered position by means of manual force and/or gravity, the undercarriage (7) being arranged to be brought from the raised position to the lowered position when the end (21) of the container (2) has been lifted above the supporting surface.
- 10 2. The lifting device (1) in accordance with claim 1, wherein the lifting device (1) includes a sliding rail (93) arranged to be locked at least in an upper position and in a lower position corresponding to the raised position and lowered position, respectively, of the undercarriage (7).
3. The lifting device (1) in accordance with claim 1 or 2, wherein, in its erect position, the tow bar (5) is arranged to be locked to the container (2) as the tow bar (5) is formed with a transverse bar (59) complementarily fitting into locking dogs (211) on the container (2).
- 25 4. The lifting device (1) in accordance with claim 3, wherein the tow bar (5) are arranged to be released from the container (2) when the undercarriage (7) is being moved into its lowered position, the transverse bar (59) of the tow bar (5) being released from the locking dogs (211) of the container (2).
5. The lifting device (1) in accordance with any one of the preceding claims, wherein the length of the tow bar (5) is adjustable as the tow bar (5) is telescopic.
- 30 6. A method of using a lifting device (1), the lifting device (1) being provided with an undercarriage (7) and the method including the steps:
  - attaching the lifting device (1) to an end (21) of the container (2); and-

lifting the end (21) of the container (2) up from the supporting surface into a lifted position, characterized in that the method further comprises the following steps:

- adjusting the undercarriage (7) from a raised position into a lowered position by means of manual force and/or gravity;
- locking the undercarriage (7) in the lowered position; and
- partially lowering the container (2) from its lifted position so that at least part of the weight of the container (2) is resting on the undercarriage (7).

5

10

7. The method in accordance with claim 6, wherein the step of lifting an end (21) of the container (2) includes lifting the container (2) with the aid of a hook-lift truck (4).

8. The method in accordance with claim 7, wherein the step of adjusting the undercarriage (7) from a raised position into a lowered position further includes extending the tow bar (5), the tow bar (5) being telescopic.

15

9. The method in accordance with claim 7 or 8, wherein the method, after the step of lifting an end (21) of the container (2), further includes adjusting one or more support legs (3) of the container (2) into a lowered position, the support legs (3) being arranged, in the lowered position, to carry at least part of the weight of the container (2).

20

10. The method in accordance with any one of claims 6-9, wherein the method further includes the steps of:

- unfolding the tow bar (5) from an erect position into an unfolded position; and

- connecting the tow bar (5) to a vehicle, whereby the container (2) can be moved by the vehicle.

25

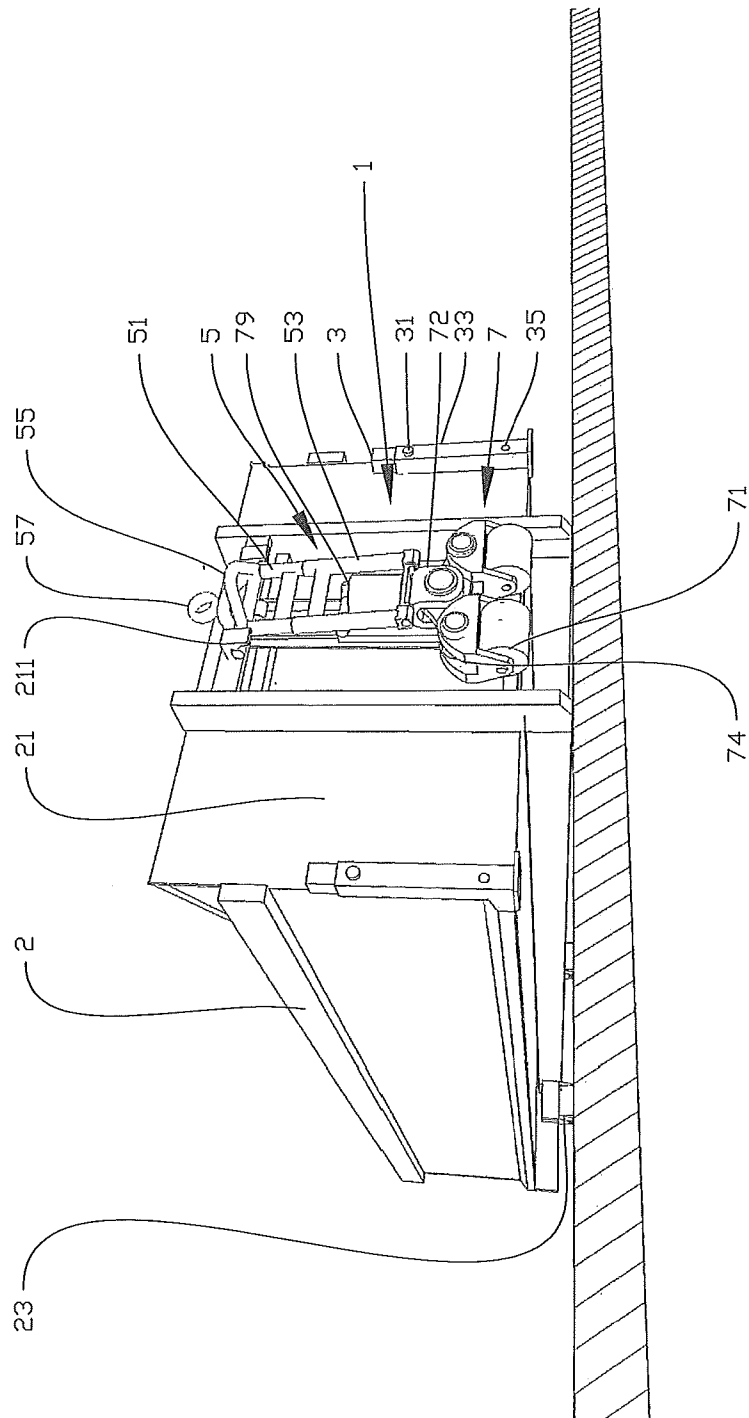

Fig. 1

2/11

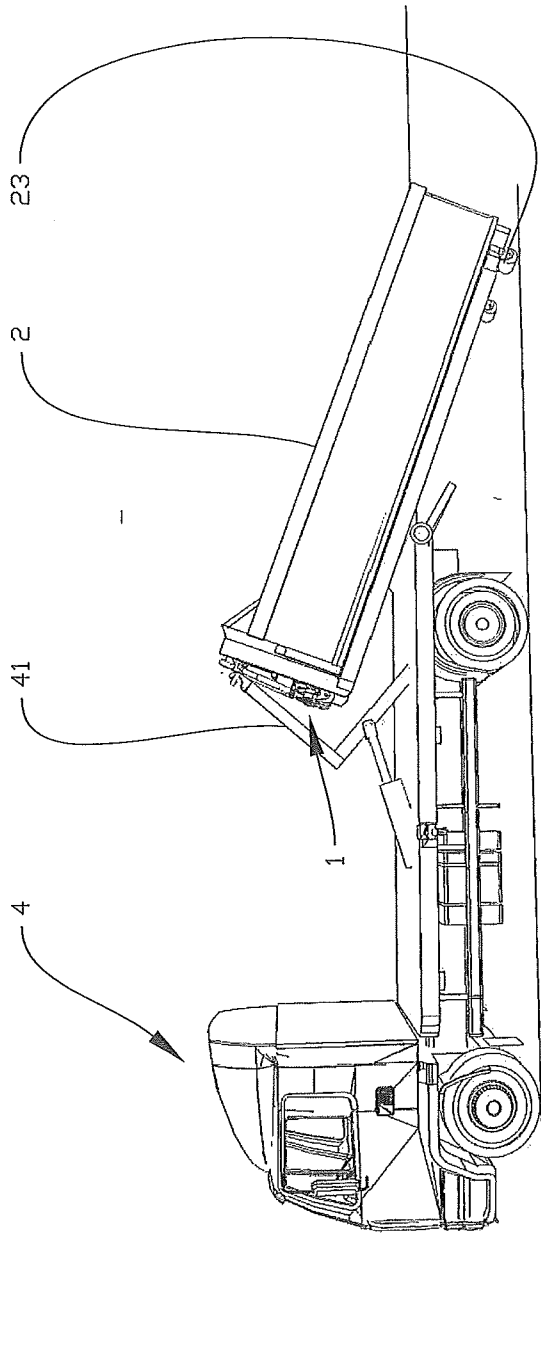

Fig. 2

3/11

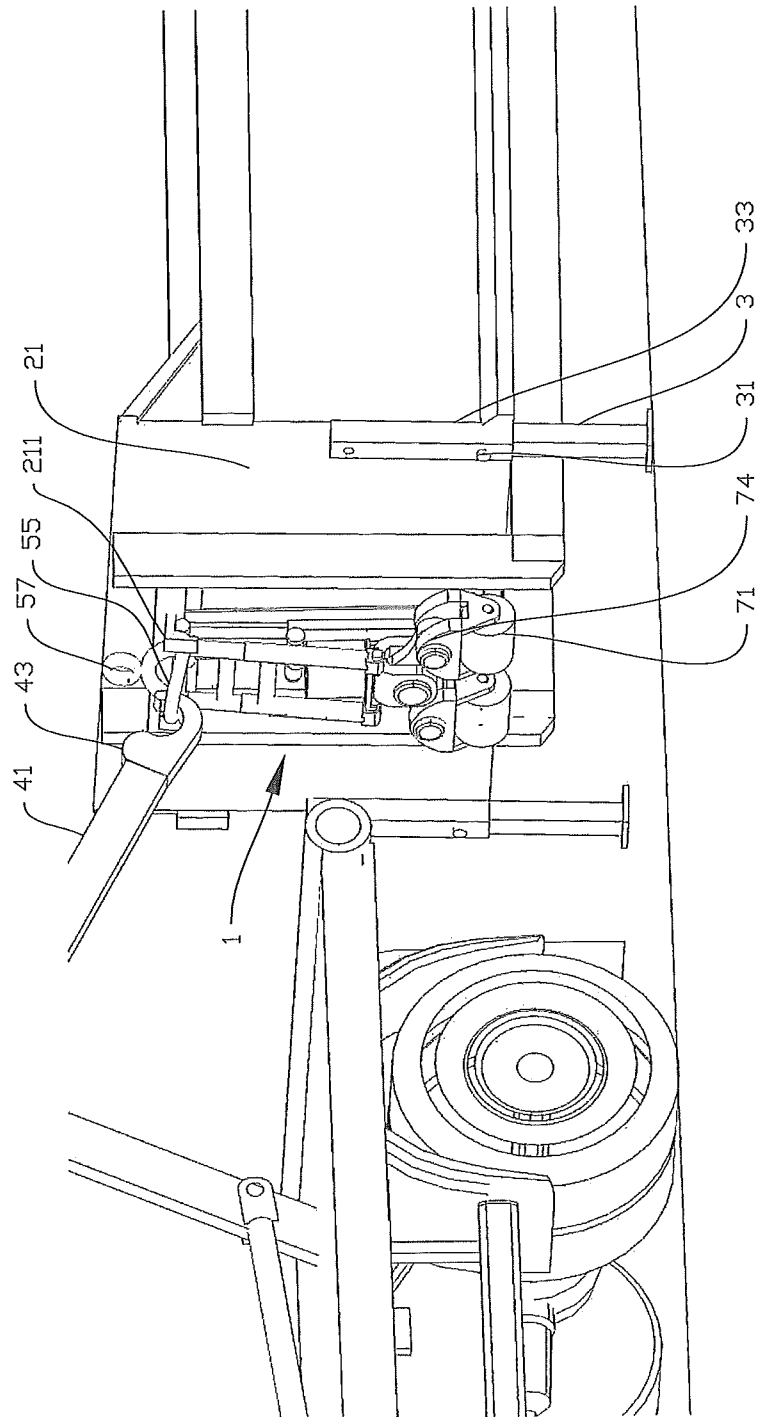

Fig. 3

4/11

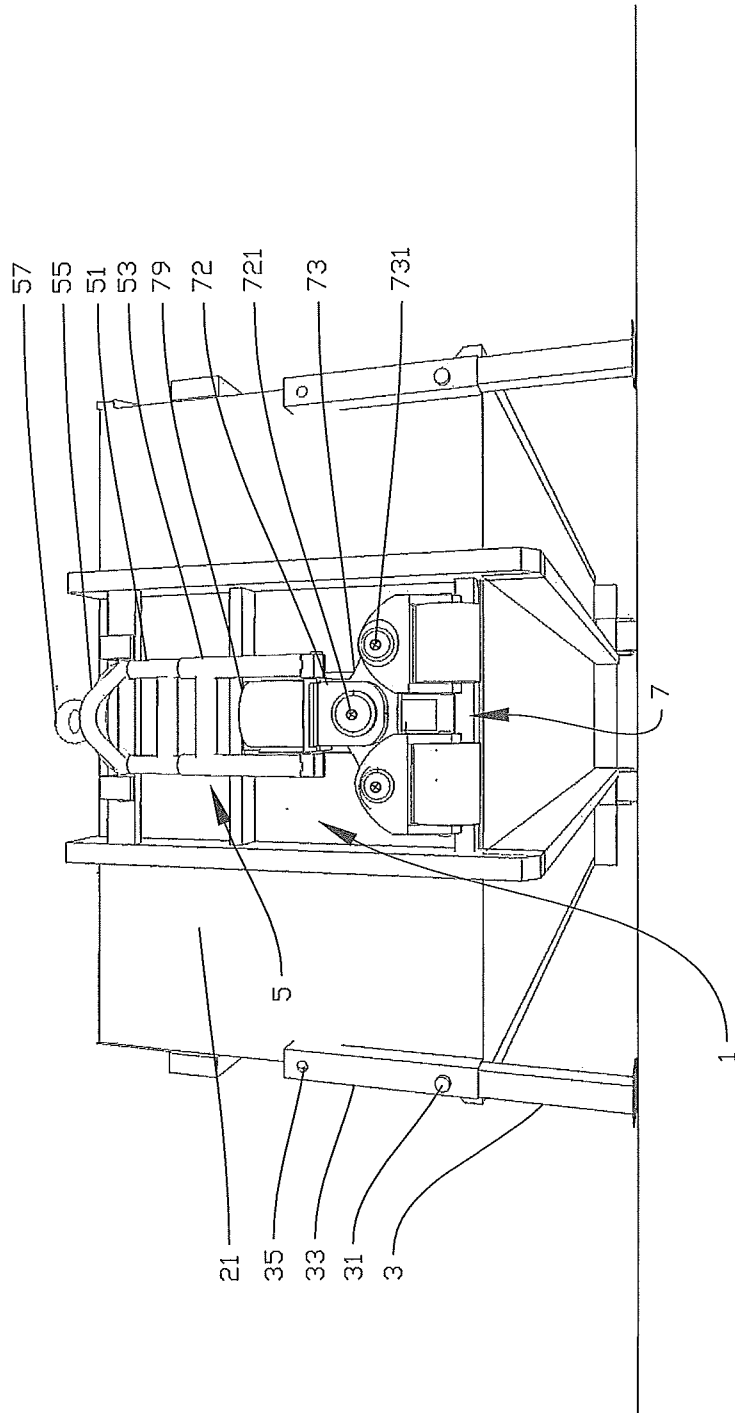

Fig. 4

5/11

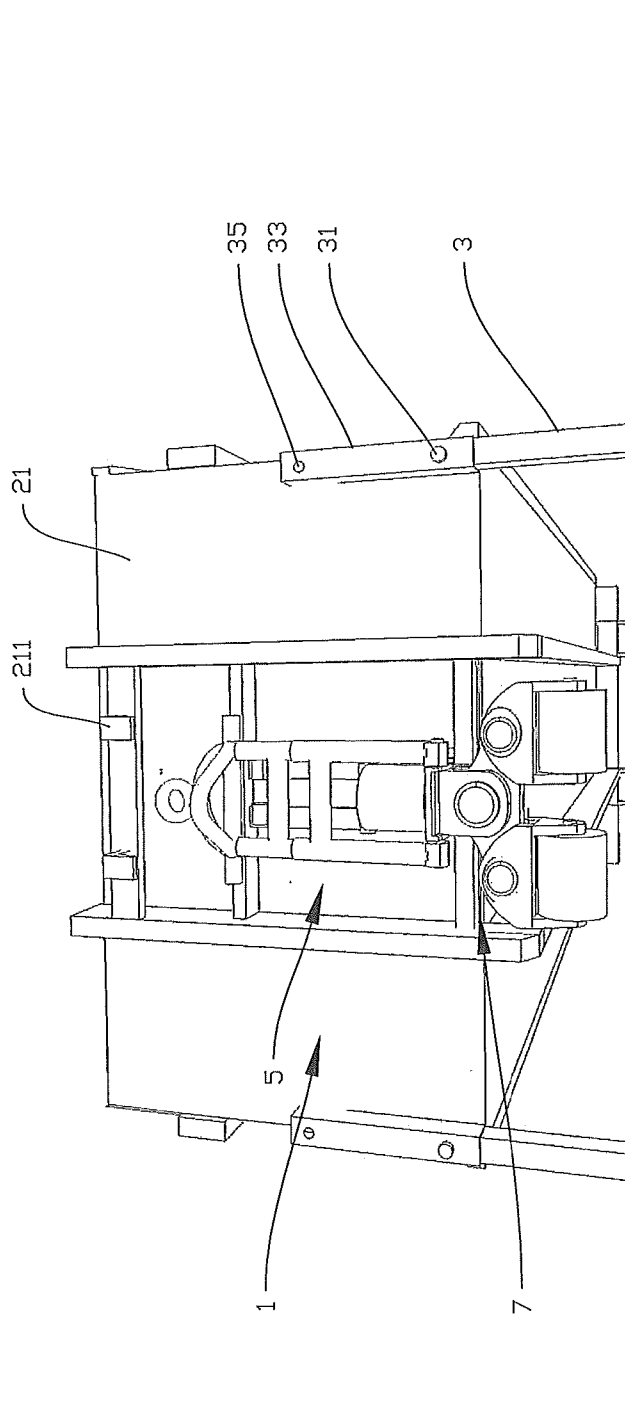

Fig. 5

6/11

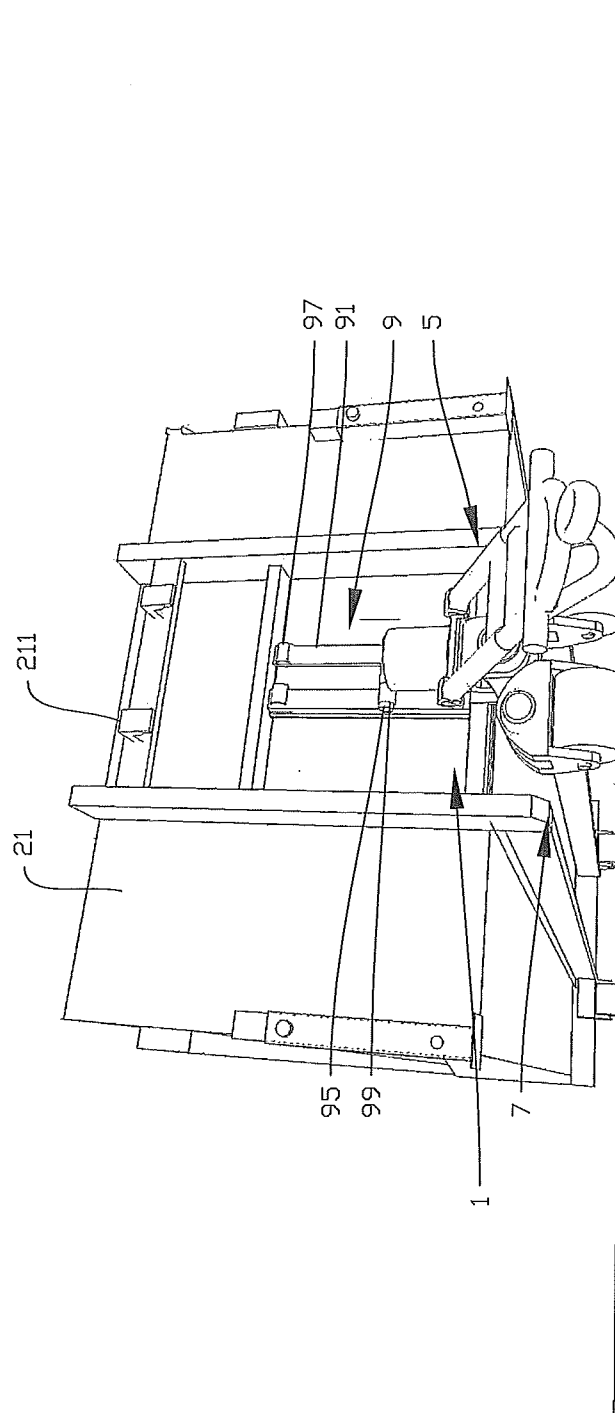

Fig. 6

7/11

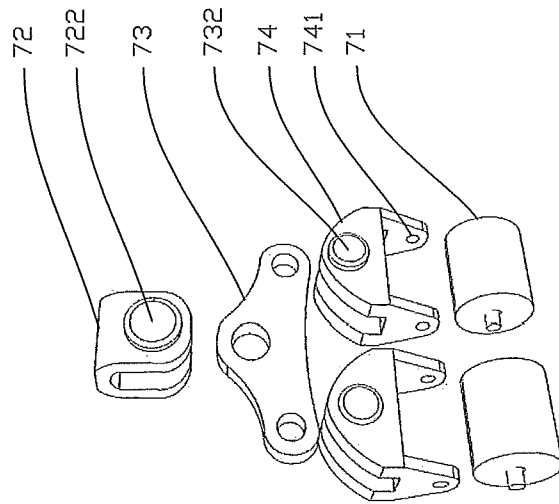

Fig. 7

8/11

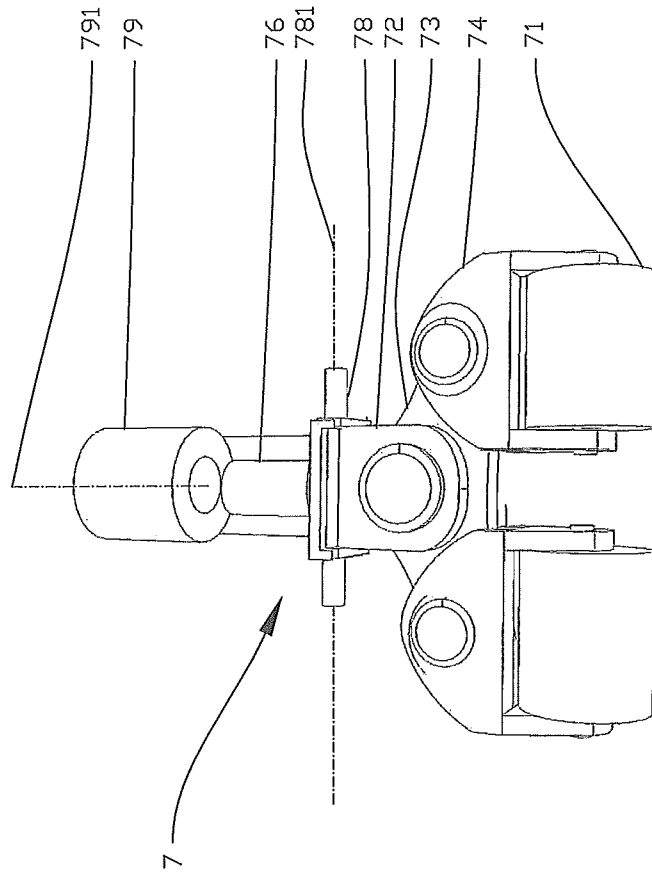

Fig. 8

9/11

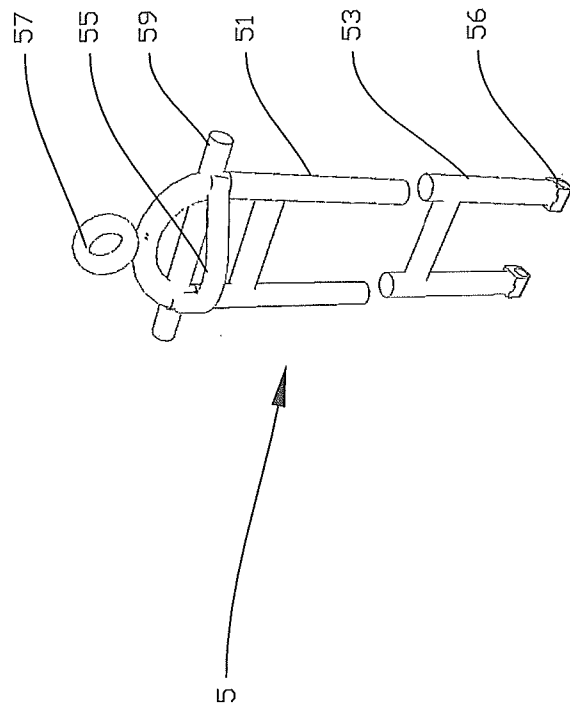

Fig. 9

10/11

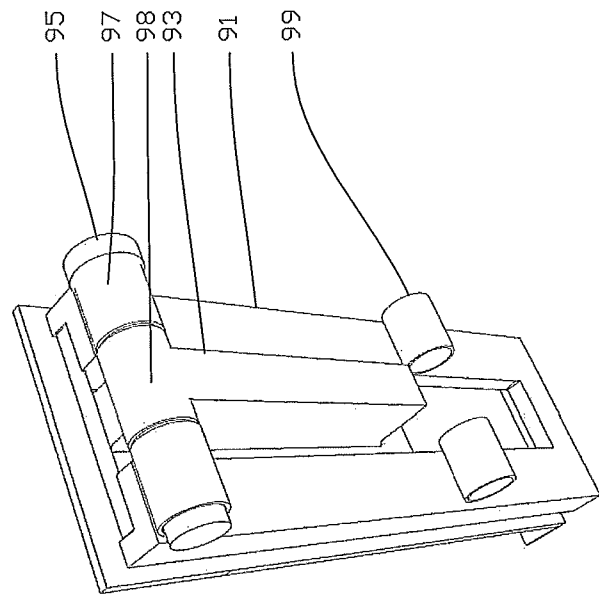

Fig. 10

11/11

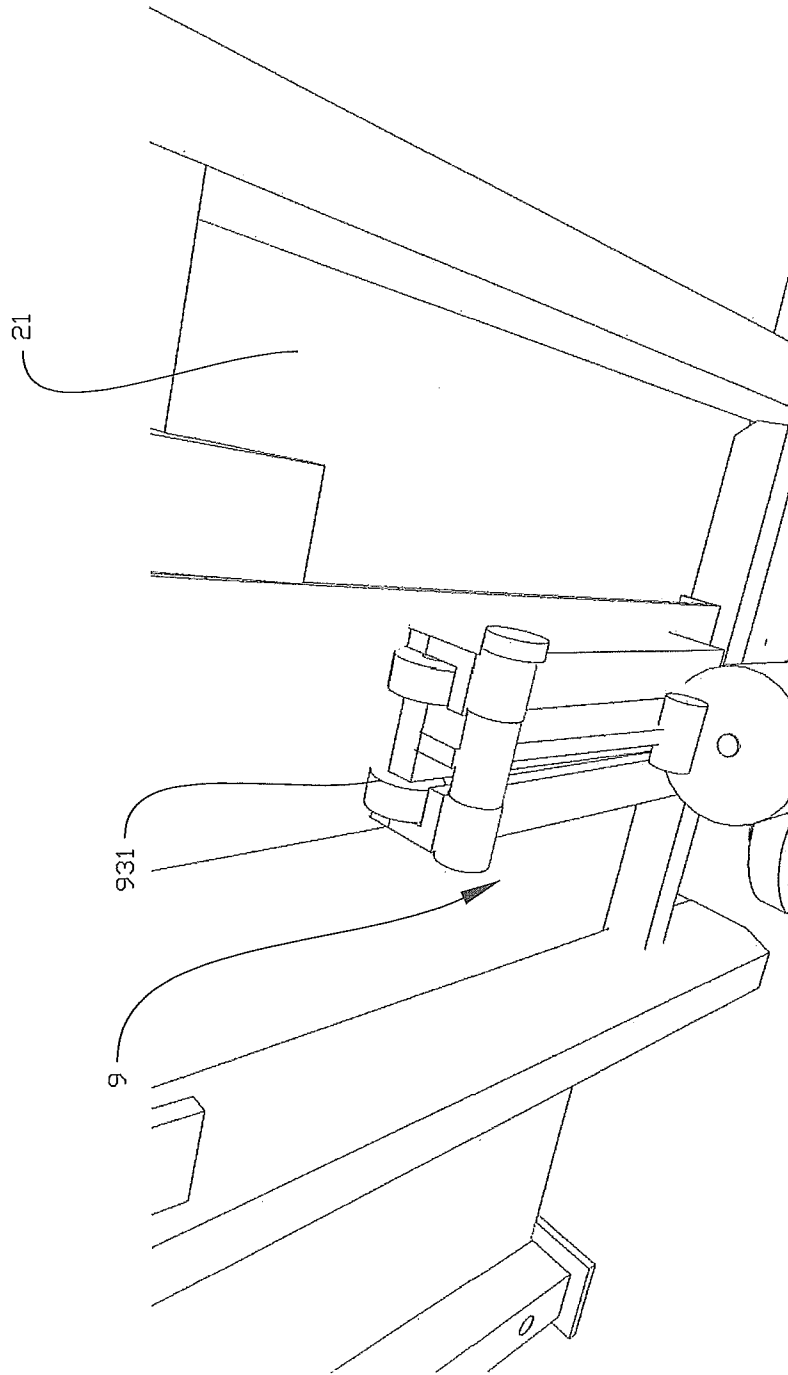

Fig. 11

## INTERNATIONAL SEARCH REPORT

International application No.  
PCT/NO2013/050209

## A. CLASSIFICATION OF SUBJECT MATTER

IPC: see extra sheet

According to International Patent Classification (IPC) or to both national classification and IPC

## B. FIELDS SEARCHED

Minimum documentation searched (classification system followed by classification symbols)

IPC: B65D

Documentation searched other than minimum documentation to the extent that such documents are included in the fields searched

SE, DK, FI, NO classes as above

Electronic data base consulted during the international search (name of data base and, where practicable, search terms used)

EPO-Internal, PAJ, WPI data

## C. DOCUMENTS CONSIDERED TO BE RELEVANT

Category*	Citation of document, with indication, where appropriate, of the relevant passages	Relevant to claim No.
Y	DE 4440180 A1 (KRESS WALTER), 23 May 1996 (1996-05-23); column 3, line 45 - column 4, line 60; figures 1,2 --	1-5
Y	WO 2012138229 A1 (FJETLAND GEIR TORE), 11 October 2012 (2012-10-11); abstract; figure 3 --	1-5, 8
X	GB 2044688 A (JONES F), 22 October 1980 (1980-10-22); page 2, line 1 - line 48; figures 1-3	6, 7, 9
Y	--	8

 Further documents are listed in the continuation of Box C. See patent family annex.

\* Special categories of cited documents:

"A" document defining the general state of the art which is not considered to be of particular relevance

"E" earlier application or patent but published on or after the international filing date

"L" document which may throw doubts on priority claim(s) or which is cited to establish the publication date of another citation or other special reason (as specified)

"O" document referring to an oral disclosure, use, exhibition or other means

"P" document published prior to the international filing date but later than the priority date claimed

"T" later document published after the international filing date or priority date and not in conflict with the application but cited to understand the principle or theory underlying the invention

"X" document of particular relevance; the claimed invention cannot be considered novel or cannot be considered to involve an inventive step when the document is taken alone

"Y" document of particular relevance; the claimed invention cannot be considered to involve an inventive step when the document is combined with one or more other such documents, such combination being obvious to a person skilled in the art

"&amp;" document member of the same patent family

Date of the actual completion of the international search

20-03-2014

Date of mailing of the international search report

20-03-2014

Name and mailing address of the ISA/SE

Patent- och registreringsverket  
Box 5055  
S-102 42 STOCKHOLM  
Facsimile No. + 46 8 666 02 86

Authorized officer

Anette Hall

Telephone No. + 46 8 782 25 00

## INTERNATIONAL SEARCH REPORT

International application No.  
PCT/NO2013/050209

C (Continuation). DOCUMENTS CONSIDERED TO BE RELEVANT

Category*	Citation of document, with indication, where appropriate, of the relevant passages	Relevant to claim No.
X	SE 390158 B (JOHANSSON PER UNO -(B) JOHANSSON P U [SE]-(C) JOHANSSON P U), 3 November 1976 (1976-11-03); page 2, paragraph [0006] - page 3, paragraph [0004]; figures 1-5 --	1
A	WO 9312996 A1 (HAEGGLUNDS MOELV AS), 8 July 1993 (1993-07-08); page 2, paragraph [0001] - page 3, paragraph [0002]; figure 1 --	1, 6
A	US 2656942 A (HELMS GEORGE V), 27 October 1953 (1953-10-27); figures 1-9 --	1
A	US 3041083 A (HENRI BLANC), 26 June 1962 (1962-06-26); column 2, line 9 - line 15; figures 1,2 --	1
A	US 5071153 A (DUNCAN LEE H), 10 December 1991 (1991-12-10); abstract; figure 1 -- -----	5, 8

**Continuation of:** second sheet  
**International Patent Classification (IPC)**  
***B65D 90/18*** (2006.01)

## INTERNATIONAL SEARCH REPORT

Information on patent family members

International application No.

PCT/NO2013/050209

DE	4440180 A1	23/05/1996	NONE		
WO	2012138229 A1	11/10/2012	AU	2012240662 A1	31/10/2013
			CA	2831831 A1	11/10/2012
			CN	103476688 A	25/12/2013
			EP	2694407 A1	12/02/2014
			NO	333058 B1	25/02/2013
			NO	20110528 A	08/10/2012
			US	20140054303 A1	27/02/2014
GB	2044688 A	22/10/1980	NONE		
SE	390158 B	03/11/1976	NO	760926 A	03/11/1976
			SE	7505114 A	03/11/1976
WO	9312996 A1	08/07/1993	AT	135655 T	15/04/1996
			CA	2104575 A1	24/06/1993
			DE	69209281 T2	01/08/1996
			DK	0572658 T3	22/07/1996
			ES	2084498 T3	01/05/1996
			FI	109894 B	31/10/2002
			FI	933686 A0	20/08/1993
			GR	3019894 T3	31/08/1996
			NO	306108 B1	20/09/1999
			NO	932966 A	20/08/1993
			US	5429472 A	04/07/1995
US	2656942 A	27/10/1953	NONE		
US	3041083 A	26/06/1962	NONE		
US	5071153 A	10/12/1991	NONE		