



- (51) **International Patent Classification:**
B65D 71/50 (2006.01) *B65D 81/36* (2006.01)
- (21) **International Application Number:**
PCT/BR2021/050293
- (22) **International Filing Date:**
06 July 2021 (06.07.2021)
- (25) **Filing Language:** English
- (26) **Publication Language:** English
- (30) **Priority Data:**
102020014115-5 09 July 2020 (09.07.2020) BR
- (72) **Inventor; and**
- (71) **Applicant: MEIRELLES, Pedro Soares de** [BR/BR];
RUA ANTÔNIO DE ALBUQUERQUE, 1.009, APTO 102,
SAVASSI, 30112-011 BELO HORIZONTE - MG (BR).
- (74) **Agent: COELHO, Luiza Tangari et al.;** RUA OLIM-
PIADAS, 242, 8° ANDAR, VILA OLIMPIA, 04551-000
SÃO PAULO - SP (BR).
- (81) **Designated States** (*unless otherwise indicated, for every
kind of national protection available*): AE, AG, AL, AM,

AO, AT, AU, AZ, BA, BB, BG, BH, BN, BR, BW, BY, BZ,
CA, CH, CL, CN, CO, CR, CU, CZ, DE, DJ, DK, DM, DO,
DZ, EC, EE, EG, ES, FI, GB, GD, GE, GH, GM, GT, HN,
HR, HU, ID, IL, IN, IR, IS, IT, JO, JP, KE, KG, KH, KN,
KP, KR, KW, KZ, LA, LC, LK, LR, LS, LU, LY, MA, MD,
ME, MG, MK, MN, MW, MX, MY, MZ, NA, NG, NI, NO,
NZ, OM, PA, PE, PG, PH, PL, PT, QA, RO, RS, RU, RW,
SA, SC, SD, SE, SG, SK, SL, ST, SV, SY, TH, TJ, TM, TN,
TR, TT, TZ, UA, UG, US, UZ, VC, VN, WS, ZA, ZM, ZW.

- (84) **Designated States** (*unless otherwise indicated, for every
kind of regional protection available*): ARIPO (BW, GH,
GM, KE, LR, LS, MW, MZ, NA, RW, SD, SL, ST, SZ, TZ,
UG, ZM, ZW), Eurasian (AM, AZ, BY, KG, KZ, RU, TJ,
TM), European (AL, AT, BE, BG, CH, CY, CZ, DE, DK,
EE, ES, FI, FR, GB, GR, HR, HU, IE, IS, IT, LT, LU, LV,
MC, MK, MT, NL, NO, PL, PT, RO, RS, SE, SI, SK, SM,
TR), OAPI (BF, BJ, CF, CG, CI, CM, GA, GN, GQ, GW,
KM, ML, MR, NE, SN, TD, TG).

Declarations under Rule 4.17:

— *of inventorship (Rule 4.17(iv))*

- (54) **Title:** INTERCHANGEABLE CONNECTION SYSTEM AND ITS USES

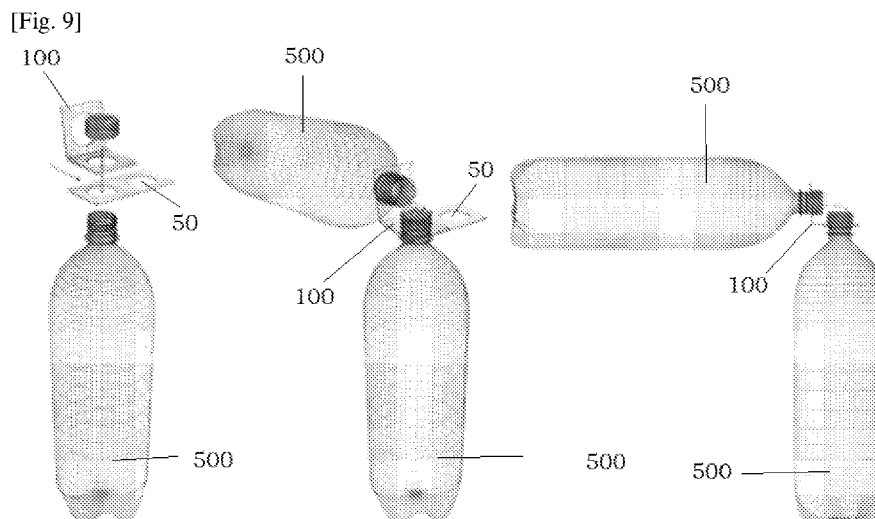

(57) **Abstract:** The present invention refers to a system of interchangeable connection, comprising one or more connectors (100), with variable configurations and angles, which have two or more circular (50) and/or oblong (60) holes in their surfaces for fixation of plastic bottles (500) in a "nut-thread" or "cap-bottle" way. In addition, the present invention addresses the use of the system for interchangeable connection for functional and/or creative purposes in the process of reusing plastic bottles (500) in a simple and practical way.



Published:

- *with international search report (Art. 21(3))*
- *in black and white; the international application as filed contained color or greyscale and is available for download from PATENTSCOPE*

Description

Title of Invention: INTERCHANGEABLE CONNECTION SYSTEM AND ITS USES

Scope of the Invention

[0001] The present invention refers to a system of interchangeable connection, comprising one or more connectors (100), with variable configurations and angles, which have two or more circular (50) and/or oblong (60) holes in their surfaces for fixation of plastic bottles (500) in a “nut-thread” or “cap-bottle” way. In addition, the present invention addresses the use of the system for interchangeable connection for functional and/or creative purposes in the process of reusing plastic bottles (500) in a simple and practical way.

Background Art

[0002] Although plastic has several important applications, its careless disposal has been causing severe consequences for the environment for decades.

[0003] Thousands of plastic bottles are purchased worldwide every minute. According to the UN, about 300 million tons of plastic waste are produced in a single year across the planet.

[0004] Upon reaching riverbeds and oceans, plastic becomes a serious contaminant of water, thus affecting the animals that live there. Eight million tons of plastic end up in the oceans each year.

[0005] Because it is a material with extremely slow decomposition (some plastics can remain intact for centuries in the environment), plastic thrown into nature represents much more than a matter of neglect with the maintenance, cleaning and conservation of public spaces. Since it never decomposes completely in the environment, there is a possibility of contamination, given that tiny particles of this material are present in the water we drink or in the meat of fish or livestock from farms and breeding grounds, which we eat.

[0006] If current trends continue as they are today, it is possible that oceans, rivers and lakes across the planet could contain more plastic than fish by 2050.

[0007] According to data from the 2015 survey of the Brazilian Association of the PET Industry (ABIPET), the disposal of packaging is 550 thousand tons per year and the recycling rate is around 51%. This figure can be considered low. As a comparison effect, the recycling of aluminum cans is over 90%, according to data from the Brazilian Association of Manufacturers of High Recyclability Cans (ABRALATAS).

[0008] One of the great difficulties of recycling is the non-selective disposal of plastic. When there is a single bottle, it will usually be disposed of as ordinary waste.

[0009] The United States patent US7,644,828B1, refers to a container that has an open upper end and a closed lower end. A chamber is provided between the upper and lower ends. The upper end is formed as a neck. The lower end is formed as a recess. Both neck and recess are essentially cylindrical. Both neck and recess have a common axis and essentially the same length and diameter. The recess is adapted to receive the neck of another bottle/container system, similarly configured. The neck is adapted to be coupled to the recess of another bottle/container system, similarly configured. The configuration of said connector presents limitations such as the connection angles and the lack of interchangeability, not allowing the creation of functional objects, such as shelves, that would provide a new use for the bottles.

[0010] The object of the United States patent US7644828B1, called *Eco-Connect Bottle*, however, has the inconvenience that, in order to be used, it requires a structural change in the plastic bottles currently used in the market. Thus, it causes additional expenses for bottle manufacturers, in addition to logistical changes to be implemented for transport and storage of the bottles in new formats. Furthermore, the lack of angular variations in the connector of said invention prevents large-scale use, making its use unfeasible in case of high demands in the recycling process.

[0011] In this context, the need to reuse bottles was identified, adapting them for use in ways other than the original, being a more convenient and practical option than recycling. Also, transforming plastic bottles into a playful, functional or decorative object is not an easy task, as it depends on skill, dexterity and almost always additional tools, such as scissors, blades, among others and accessories, in addition to a lot of creativity.

[0012] After verifying these issues, the Patent Applicant developed an interchangeable connector system that connect to the plastic bottles currently used to form objects both playful and practical, and which allows a drastic and timely change in the possibilities of reusing plastic bottles, without increasing costs for the manufacturers of these bottles and without needing to modify any existing bottle.

Brief description of the Drawings

[0013] The present invention will be better visualized with the attached drawings, which are examples of its configurations and uses:

[0014] [Fig.1] shows perpendicular, top, side and front views of an example of a rigid connector, with 2 circular holes.

[0015] [Fig.2] shows perpendicular, top, side and front views of an example of a rigid connector in a U-shape configuration, with a hole on each side.

[0016] [Fig.3] shows perpendicular, top, side and front views of an example of an L-shaped connector, with a 90° angle, with a hole on each side.

- [0017] [Fig.4] shows perpendicular, top, side and front views of an example of an L-shaped connector, with a 120° angle, with a hole on each side.
- [0018] [Fig.5] shows perpendicular, top, side and front views of an example of L-shaped connector, with a 150° angle, with a hole on each side.
- [0019] [Fig.6] shows perpendicular, top, left and right side and front views of an example of L-shaped connector, with a 90° angle, with one hole on each side, and 2 holes on the flat part.
- [0020] [Fig.7] shows perpendicular, top, side and front views of an example of a V-shaped connector, with a 120° angle, with a hole on each side.
- [0021] [Fig.8] shows the application of the interchangeable connection system of the invention by using a connector with two circular holes, through the nut and screw system, with the connector being fixed between them.
- [0022] [Fig.9] shows the application of the interchangeable connection system of the invention by using an L-shaped connector with two circular holes, combined with a connector with two circular holes.
- [0023] [Fig.10] shows the application of the system for interchangeable connection of the invention by using a flexible connector with circular holes.
- [0024] [Fig.11] shows the application of the interchangeable connection system of the invention by using a single rigid connector with two holes, an oblong hole and a circular hole.
- [0025] [Fig.12] shows examples of other possible configurations of the connectors of the interchangeable connection system of this invention.
- [0026] [Fig.13] is the top view of an example of an L-shaped connector, with three circular holes.

Description of the Invention

- [0027] The present invention refers to a system of interchangeable connection, comprising one or more connectors (100), with variable configurations and angles, which have two or more circular (50) and/or oblong (60) holes in their surfaces for fixation of plastic bottles (500) in a “nut-thread” or “cap-bottle” way. In addition, the present invention addresses the use of the system for interchangeable connection for functional and/or creative purposes in the process of reusing plastic bottles (500) in a simple and practical way.
- [0028] In cases in which the connectors allow for the setting up of bottles (500) sideways, next to each other, the connectors (100) of the system of this invention show a 0° angle, which can vary up to 180°, in the case where a bottle (500) will be in an inverted position, in relation to another. Thus, such angular constructions of the connectors (100) vary according to the need for setting up the final configuration.

- [0029] In particular, the flat connectors (100) can have straight L-shaped configurations, with 90° angles for a straight curve, as well as a curve with a different angle, for setting up the final configuration.
- [0030] Those connectors (100) can also be presented in “Y”, “Ψ” configurations, or any other configuration. There is also the possibility that the connectors (100) are presented in a hybrid configuration, that is, with duplicators in the flat line and varied angles.
- [0031] The connectors (100) of the interchangeable connection system of this application are comprised of two or more circular (50) and/or oblong (60) holes, with diameters ranging from 10 to 50 mm, preferably from 15 to 30 mm.
- [0032] The distance between the holes (50, 60) of the connector (100) of this invention can range from 30 mm to 1,000 mm.
- [0033] The number of holes present in the connector (100) can vary, preferably between 2 and 50 holes.
- [0034] The connectors (100) are comprised of rigid and/or flexible materials, such as, for example, thermoset and/or thermoplastic polymers.
- [0035] The present invention also addresses the use of the interchangeable connection set, comprising at least one connector (100), with functional and/or creative purposes in the process of reusing said bottles (500).
- [0036] In a special way, the combination of said connectors (100) allows the creation of decorative, functional, playful objects from the recycling of PET bottles (500).
- [0037] As the connectors (100) are interchangeable and joined through the bottle itself (500), the configuration of the objects becomes intuitive. Manuals – either digital or printed (where there is this demand and the impossibility of digital access), as well as tutorials on the internet, with suggestions, tips, guidelines, remarks, can assist in the formation, implementation and dissemination of various pre-designed objects by people from around the world.
- [0038] The effective dissemination of the connectors (100) - their functionalities and possibilities – and the easy understanding by children, adolescents and adults of different ages, social classes, school level and different regions, will be essential in the process of change. With an infinite number of configurations and possible uses, allowing and favoring the grouping of several bottles (500), the tendency is that the disposal is carried out in plastic batches, separated from the other items. Or, even, that this disposal be suppressed, with people prioritizing its practical, aesthetic, playful and/or functional use, through the use associated with the interchangeable connectors (100). The benefits of these simple connections make a multitude of reuses possible.

Claims

- [Claim 1] INTERCHANGEABLE CONNECTION SYSTEM, **wherein** one or more connectors (100) of variable configurations and angles, which have two or more circular (50) and/or oblong (60) holes on their surfaces for fixation of plastic bottles (500) in a “nut-thread” or “cap-bottle” way.
- [Claim 2] SYSTEM, according to claim 1, **wherein** connectors (100) have angles ranging from 0° to 180°.
- [Claim 3] SYSTEM, according to either of Claims 1 or 2, **wherein** connectors (100) have straight configurations, L-shaped, with 90° angles for a straight curve.
- [Claim 4] SYSTEM, according to any one of Claims 1 to 3, **wherein** said connectors (100) are also presented in “Y,” “Ψ” or other configurations.
- [Claim 5] SYSTEM, according to any one of Claims 1 to 4, **wherein** connectors (100) have a hybrid configuration, that is, with duplicators in the flat line and varying angles.
- [Claim 6] SYSTEM, according to Claim 1, **wherein** connectors (100) have circular (50) and/or oblong (60) holes comprising diameters ranging from 10 to 50 mm, preferably from 15 to 30 mm.
- [Claim 7] SYSTEM, according to Claim 6, **wherein** the distance between the holes (50, 60) of the connector (100) range from 30 mm to 1,000 mm.
- [Claim 8] SYSTEM, according to Claim 6, **wherein** the number of holes present in the connector (100) range from 2 to 50.
- [Claim 9] SYSTEM, according to any one of Claims 1 to 8, **wherein** connectors (100) comprise rigid and/or flexible materials, such as thermoset and/or thermoplastic polymers.
- [Claim 10] USE OF THE INTERCHANGEABLE CONNECTION SYSTEM, as defined in Claims 1 to 9, **wherein** they have functional and/or creative purposes in the process of reusing plastic bottles (500).
- [Claim 11] USE, according to Claim 10, **wherein** the reuse of plastic bottles (500) comprises the creation of decorative, functional, playful objects.

[Fig. 1]

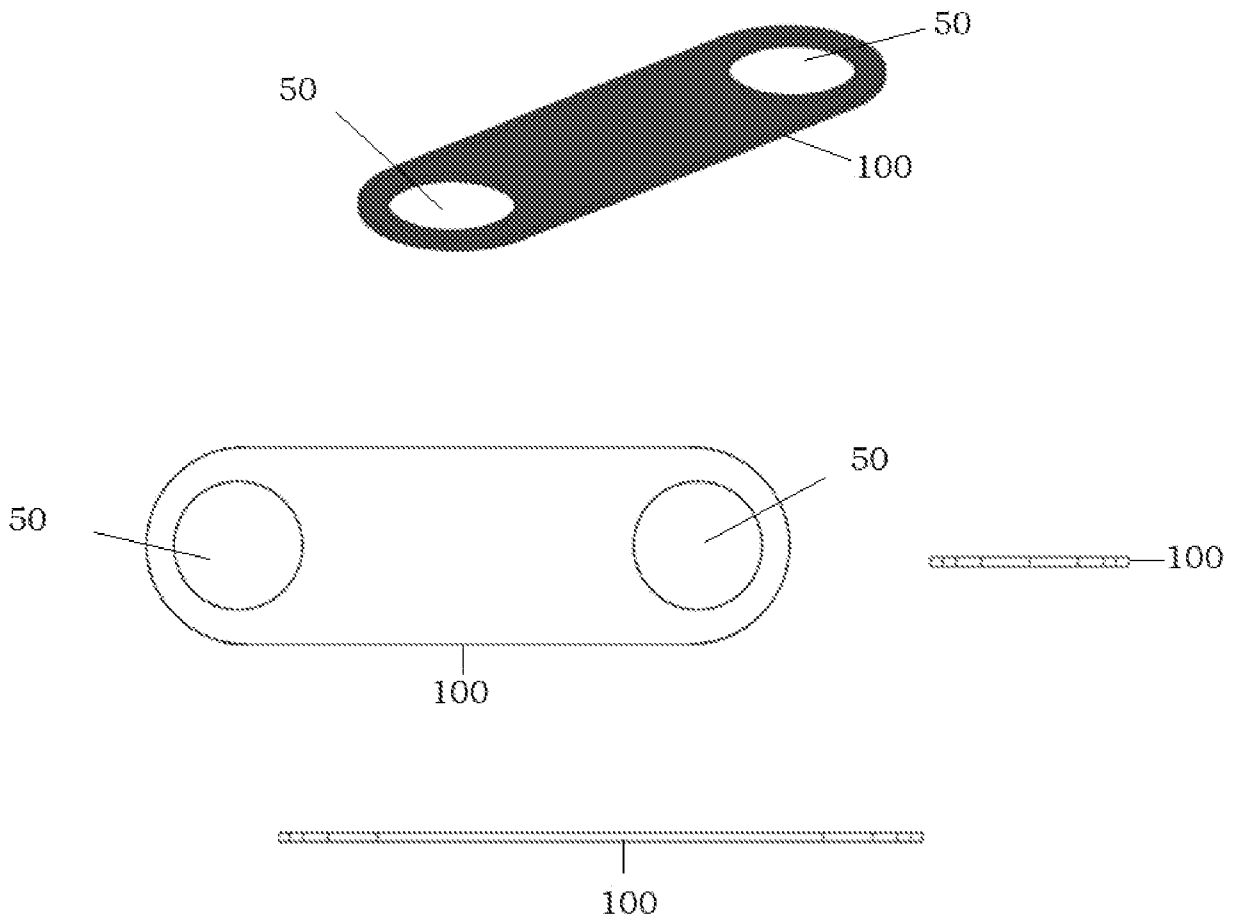

[Fig. 2]

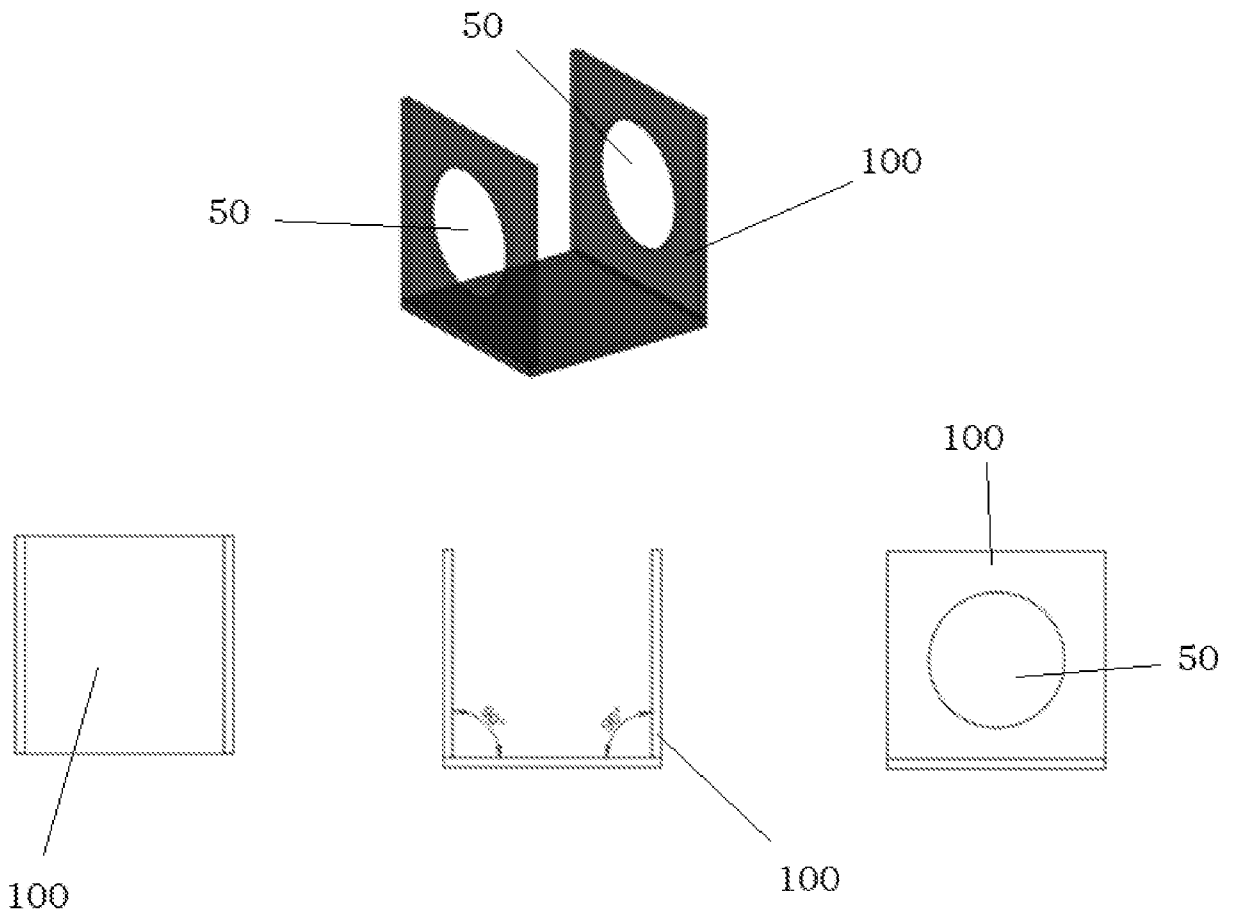

[Fig. 3]

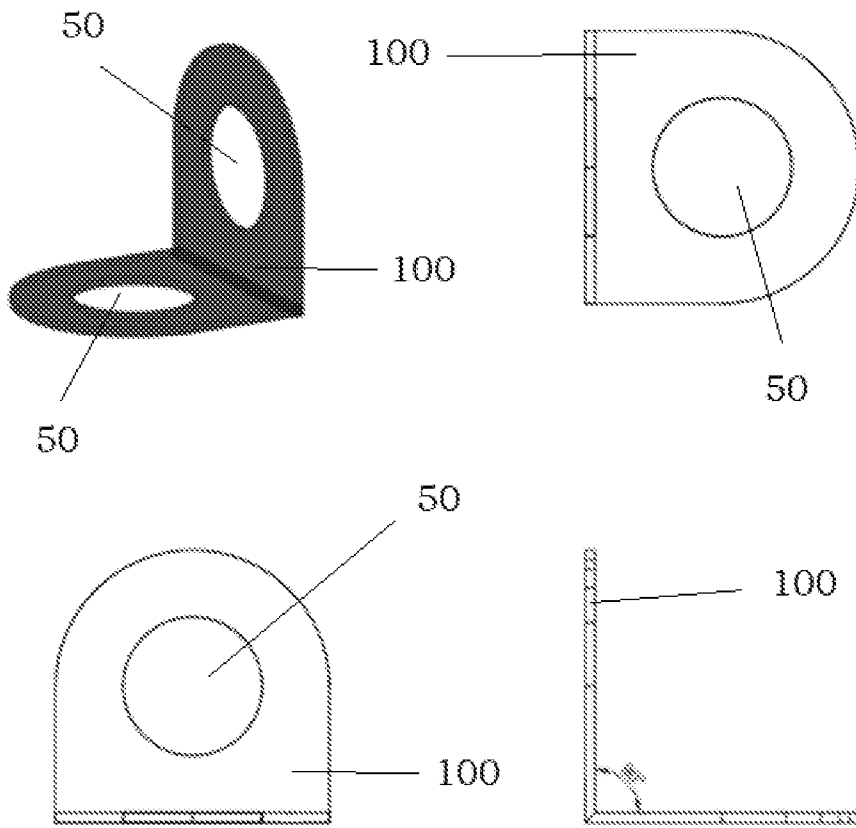

[Fig. 4]

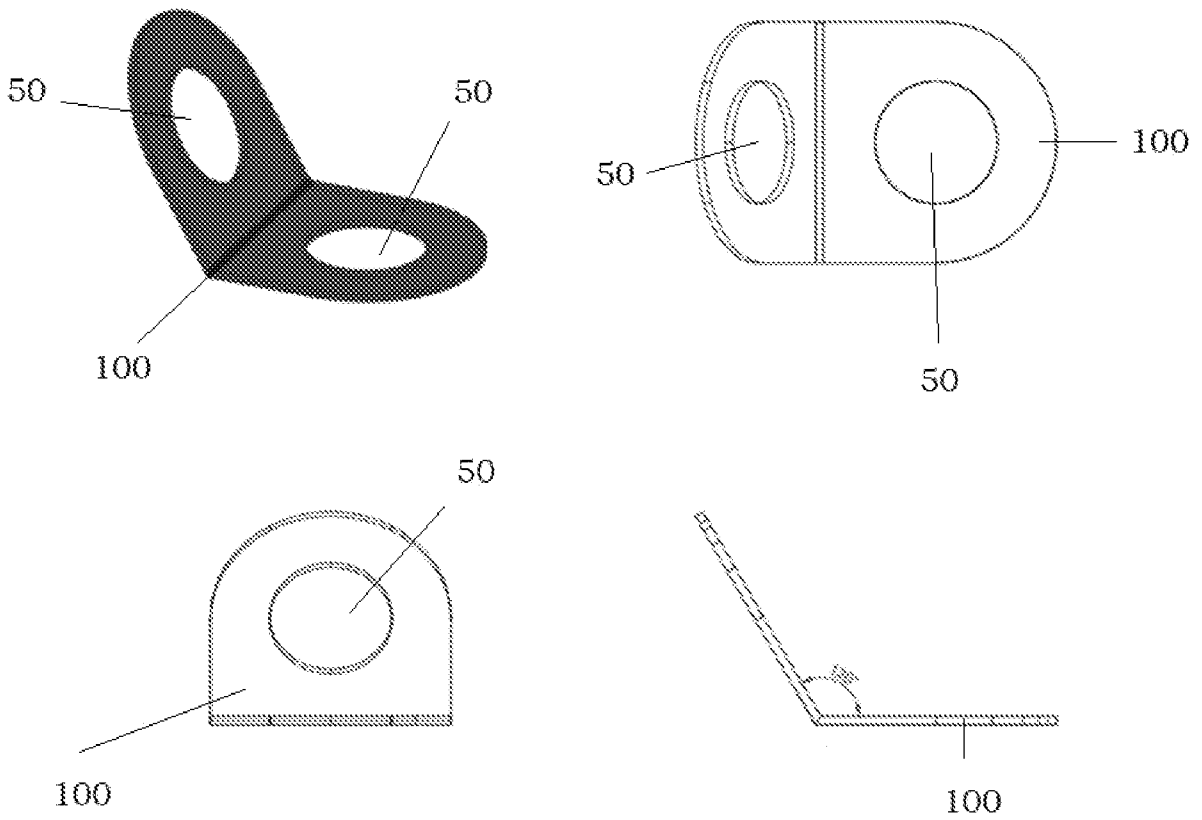

[Fig. 5]

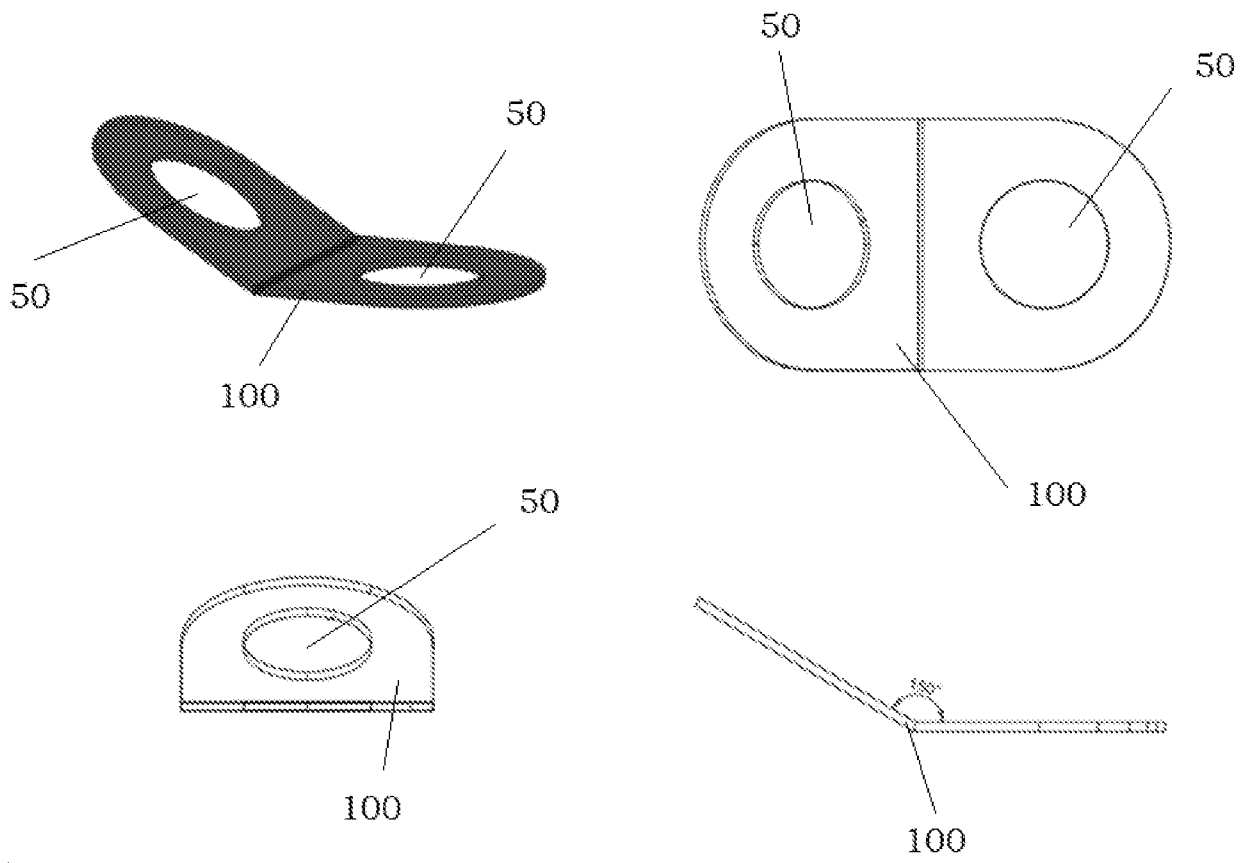

[Fig. 6]

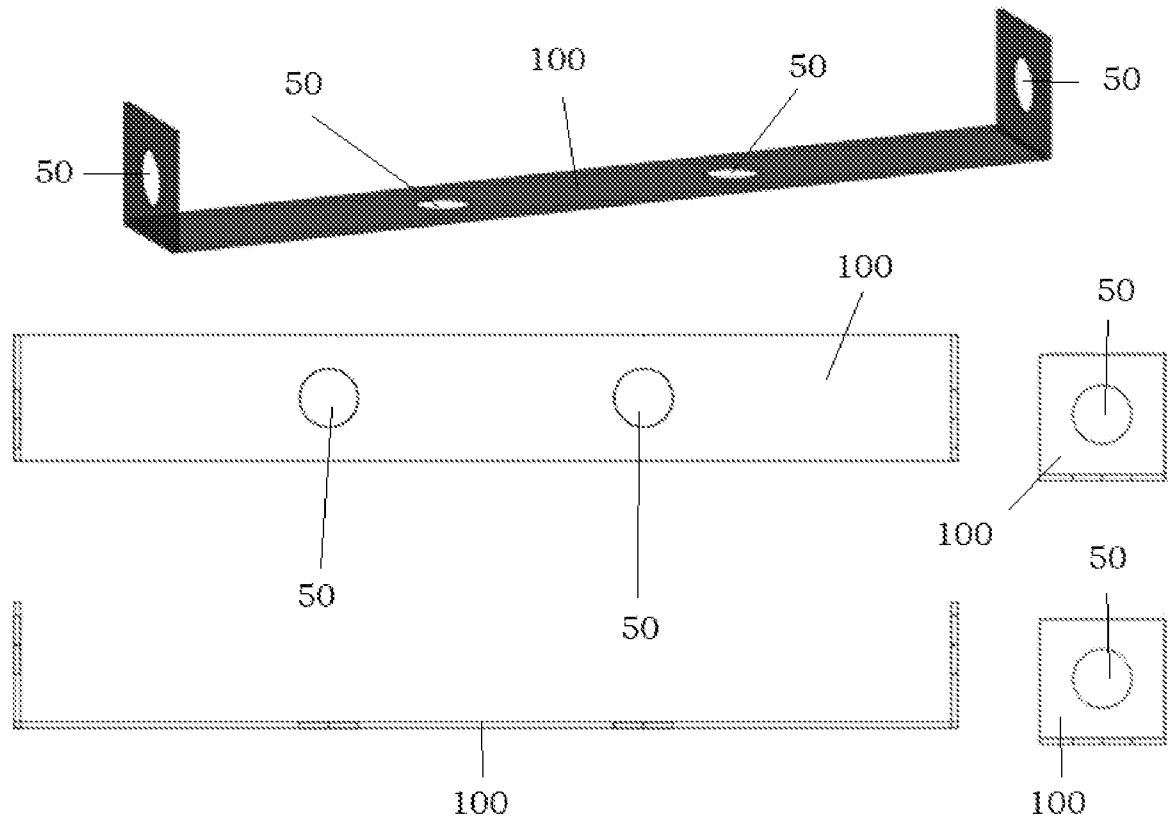

[Fig. 7]

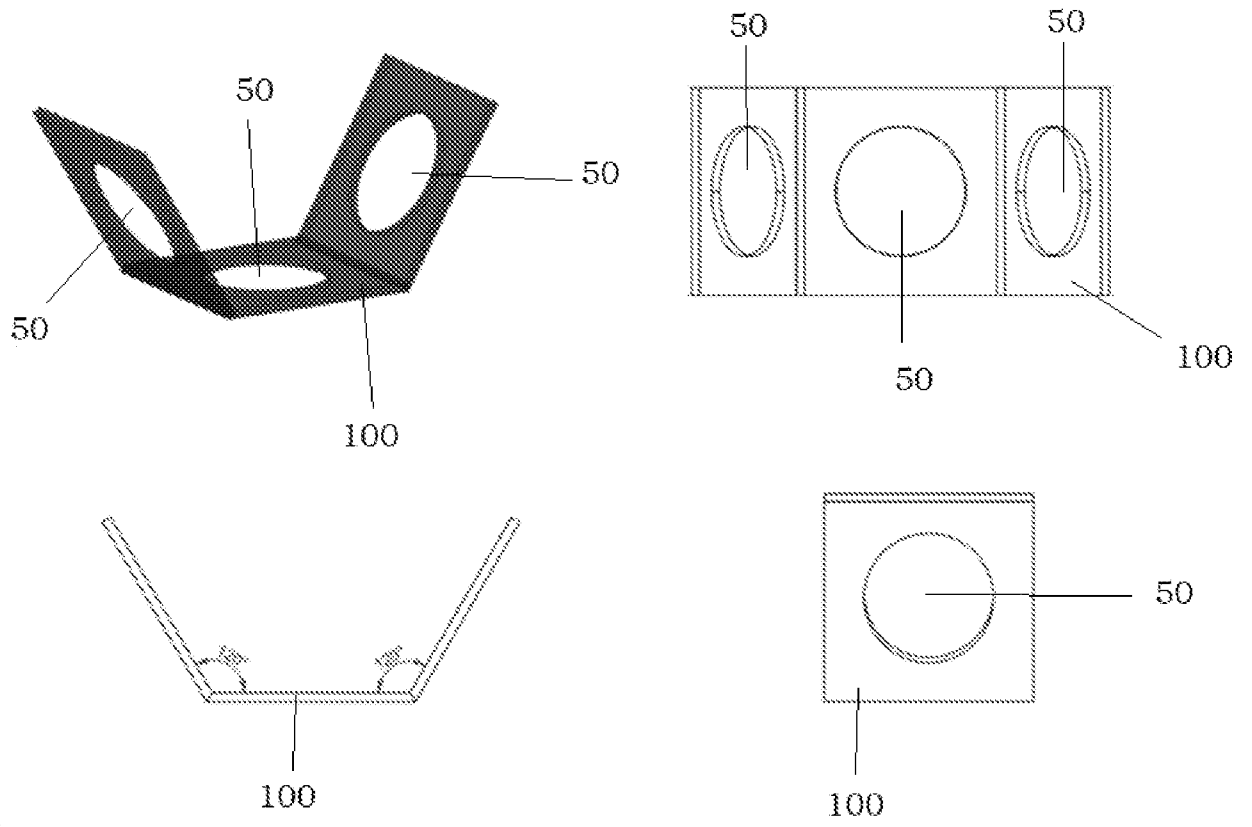

[Fig. 8]

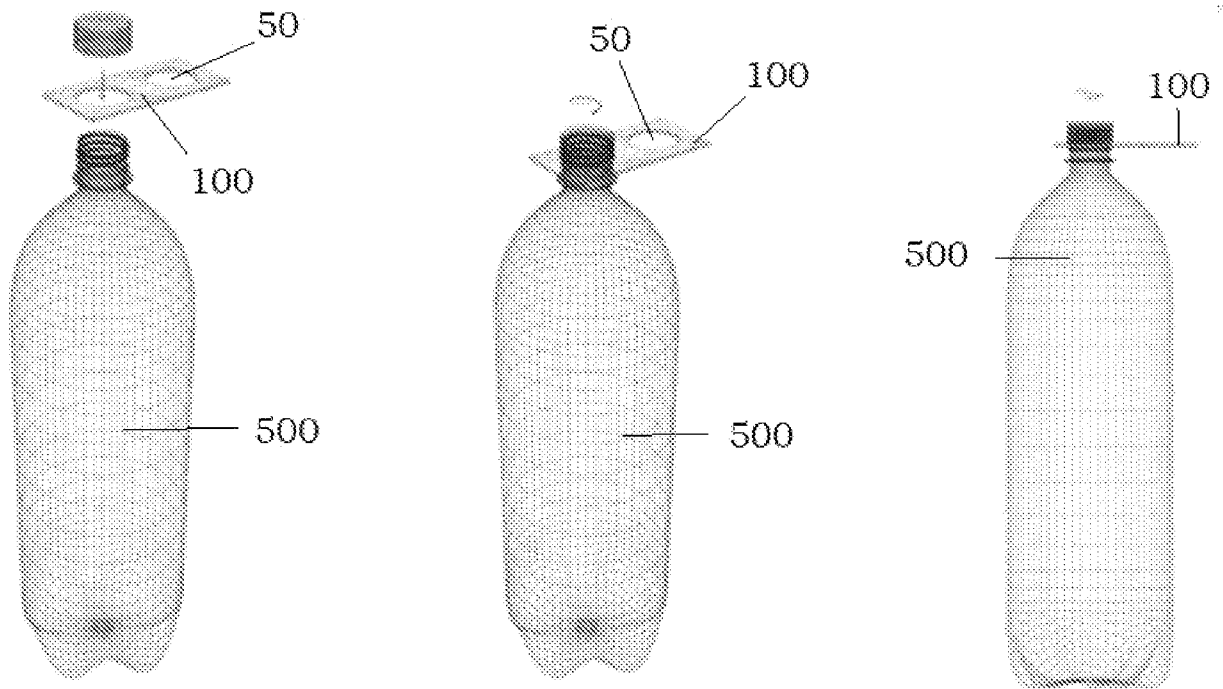

[Fig. 9]

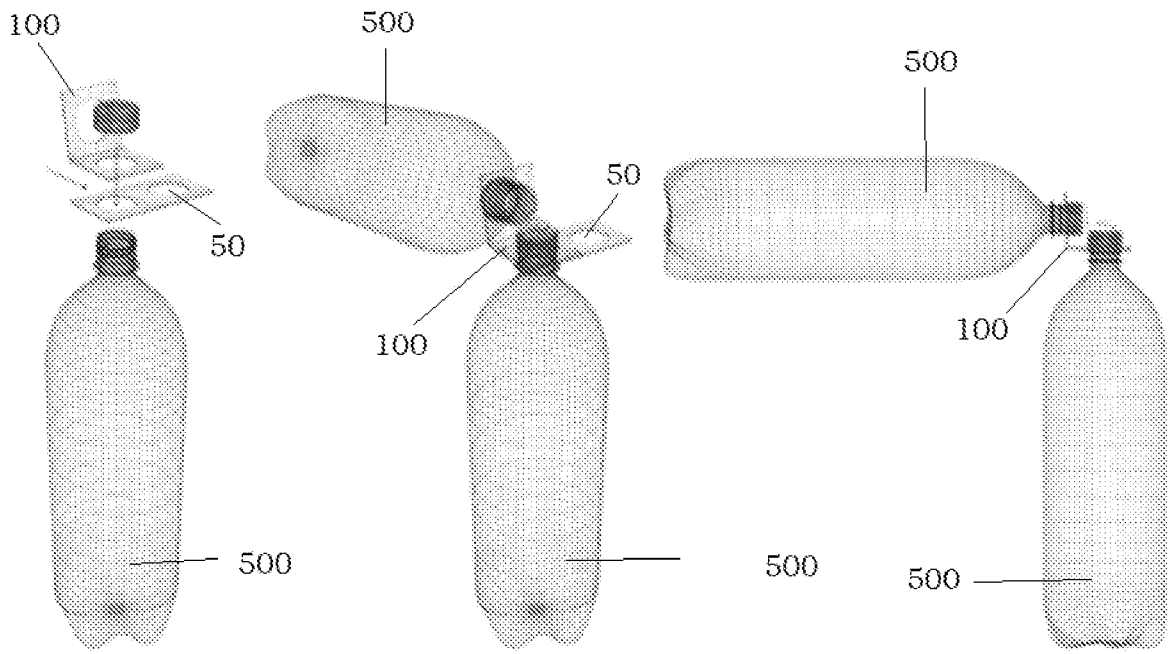

[Fig. 10]

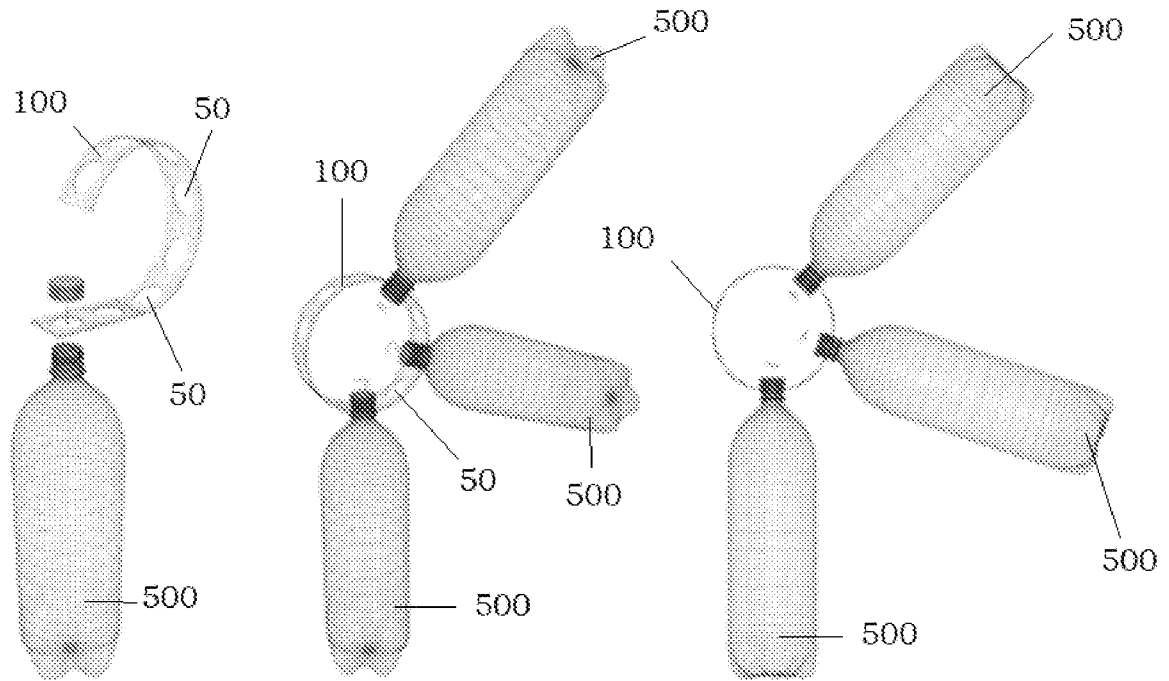

[Fig. 11]

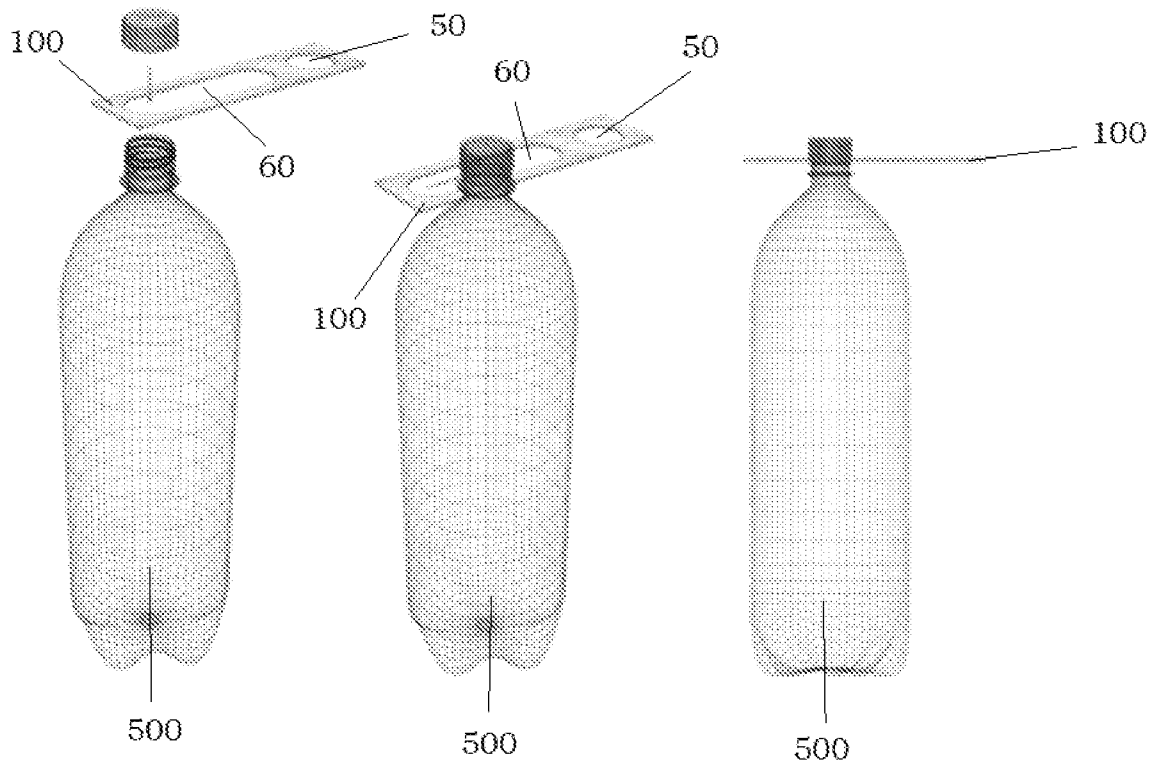

[Fig. 12]

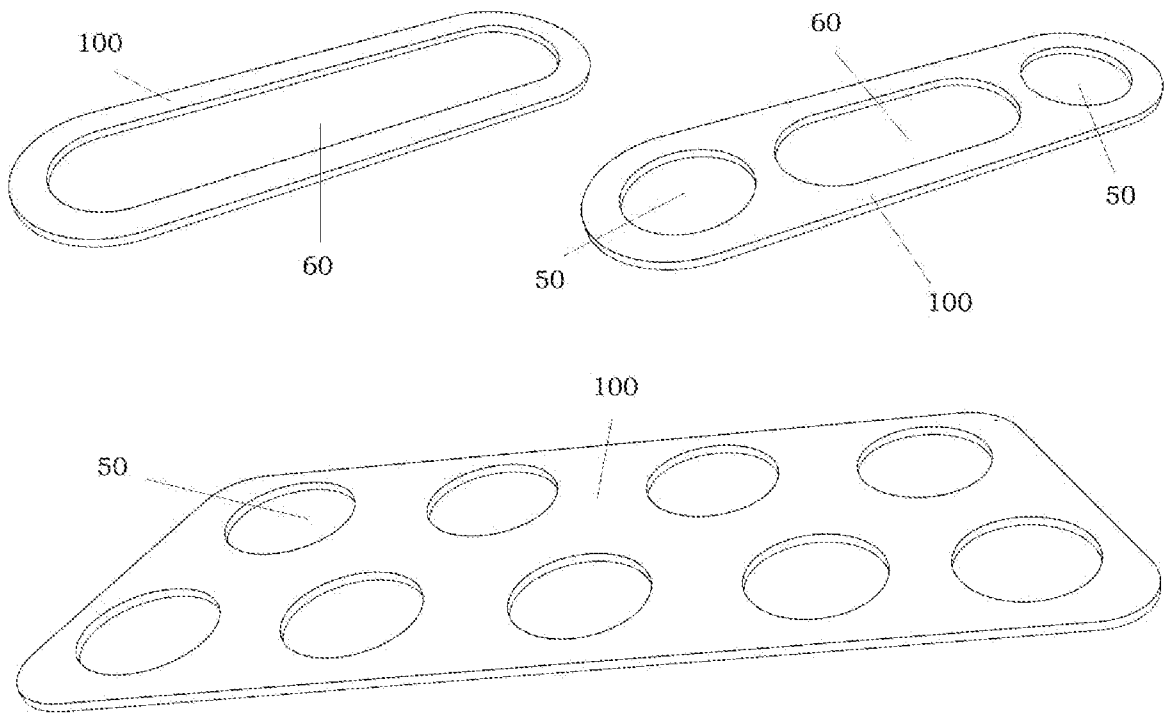

[Fig. 13]

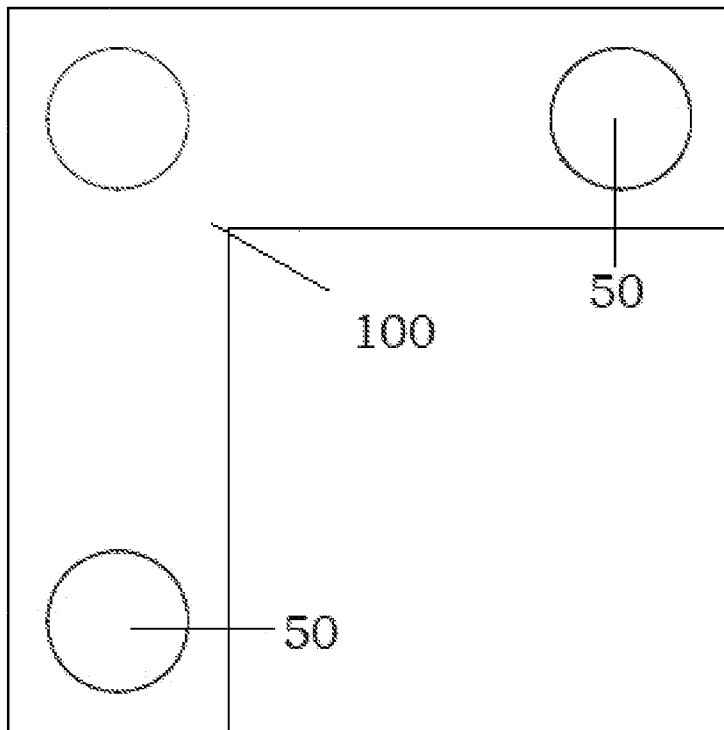

A. CLASSIFICATION OF SUBJECT MATTER IPC: B65D 71/50 (2006.01), B65D 81/36 (2006.01) CPC: B65D 71/504, B65D 81/361 According to International Patent Classification (IPC) or to both national classification and IPC		
B. FIELDS SEARCHED Minimum documentation searched (classification system followed by classification symbols) B65D Documentation searched other than minimum documentation to the extent that such documents are included in the fields searched INPI-BR Patent Base Electronic data base consulted during the international search (name of data base and, where practicable, search terms used) DERWENT INNOVATION INDEX		
C. DOCUMENTS CONSIDERED TO BE RELEVANT		
Category*	Citation of document, with indication, where appropriate, of the relevant passages	Relevant to claims N°
X	AU 2018101104 A4 (FERNANDES MICHAEL JOHN [AU]) 06 September 2018 (2018-09-06) Figures 1-6; abstract and paragraphs [0007]-[0009] -----	1-11
X	US 2426750 A (REUTNER EMIL A) 02 September 1947 (1947-09-02) Figures 1-3; column 2, lines 20-54 -----	1-11
A	US 2299625 A (BLOOMER BROS CO) 20 October 1942 (1942-10-20) The whole document -----	1-11
A	DE 20305696 U1 (TARIN RALF UWE [DE]) 14 August 2003 (2003-08-14) The whole document -----	1-11
<input type="checkbox"/> Further documents are listed in the continuation of Box C. <input checked="" type="checkbox"/> See patent family annex.		
* Special categories of cited documents: "A" document defining state of the art which is not considered to be of particular relevance "E" earlier application or patent but published on or after the international filing date "L" document which may throw doubts on priority claim(s) or which is cited to establish the publication date of another citation or other special reason (as specified) "O" document referring to an oral disclosure, use, exhibition or other means "P" document published prior to the international filing date but later than the priority claimed "T" later document published after the international filing date or priority date and not in conflict with the application but cited to understand the principle or theory underlying the invention "X" document of particular relevance; the claimed invention cannot be considered novel or cannot be considered to involve an inventive step when the document is taken alone "Y" document of particular relevance; the claimed invention cannot be considered to involve an inventive step when the document is combined with one or more other such documents, such combination being obvious to a person skilled in the art "&" document member of the same patent family		
Date of the actual completion of the international search 17/09/2021		Date of mailing of the international search report 30/09/2021
Name and mailing address of the ISA/BR  INSTITUTO NACIONAL DA PROPRIEDADE INDUSTRIAL Rua Marink Veiga n° 9, 6° andar cep: 20090-910, Centro - Rio de Janeiro/RJ +55 21 3037-3663 Facsimile N°:		Authorized officer Ive Luciana Coelho da Costa Resende Telephone N°: +55 21 3037-3493/3742

