

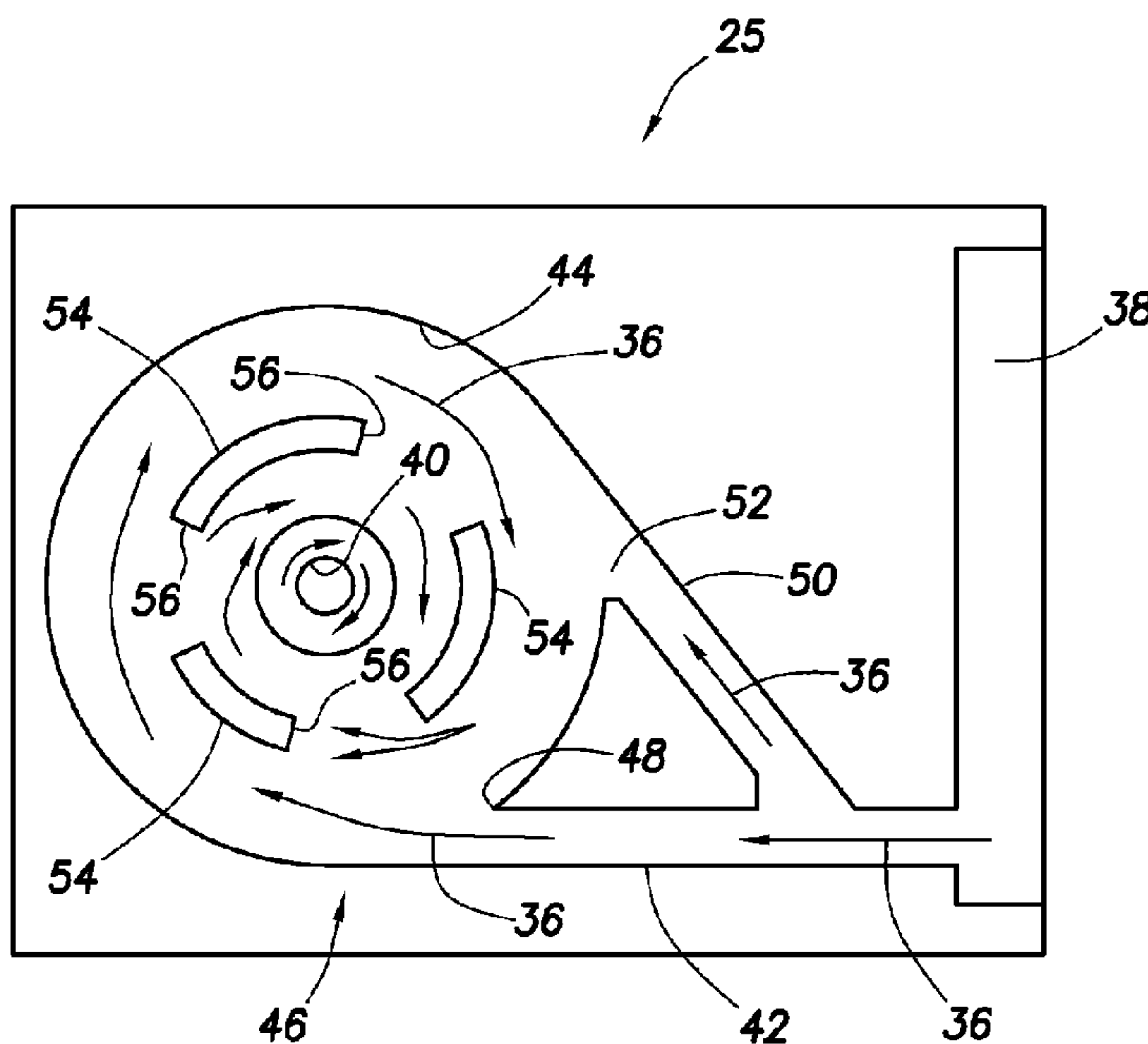

(86) **Date de dépôt PCT/PCT Filing Date:** 2011/08/24
 (87) **Date publication PCT/PCT Publication Date:** 2012/03/15
 (45) **Date de délivrance/Issue Date:** 2015/11/17
 (85) **Entrée phase nationale/National Entry:** 2013/02/21
 (86) **N° demande PCT/PCT Application No.:** US 2011/048986
 (87) **N° publication PCT/PCT Publication No.:** 2012/033638
 (30) **Priorité/Priority:** 2010/09/10 (US12/879,846)

(51) **Cl.Int./Int.Cl. E21B 34/06** (2006.01),
E21B 43/00 (2006.01)
 (72) **Inventeur/Inventor:**
DYKSTRA, JASON D., US
 (73) **Propriétaire/Owner:**
HALLIBURTON ENERGY SERVICES, INC., US
 (74) **Agent:** NORTON ROSE FULBRIGHT CANADA
LLP/S.E.N.C.R.L., S.R.L.

(54) **Titre : RESTRICTEURS A DEBIT VARIABLE DISPOSES EN SERIE POUR ETRE UTILISES DANS UN PUIT SOUTERRAIN**
 (54) **Title: SERIES CONFIGURED VARIABLE FLOW RESTRICTORS FOR USE IN A SUBTERRANEAN WELL**



(57) **Abrégé/Abstract:**

A variable flow resistance system can include a vortex device, with resistance to flow of a fluid composition through the vortex device being dependent on a rotation of the fluid composition at an inlet to the vortex device. Another system can include a second vortex device which receives a fluid composition from an outlet of a first vortex device, a resistance to flow of the fluid composition through the second vortex device being dependent on a rotation of the fluid composition at the outlet. Another system can include a first vortex device which causes increased rotation of a fluid composition at an outlet thereof in response to an increase the fluid composition velocity, and a second vortex device which receives the fluid composition from the outlet, a flow resistance through the second vortex device being dependent on the rotation of the fluid composition at the outlet.

(12) INTERNATIONAL APPLICATION PUBLISHED UNDER THE PATENT COOPERATION TREATY (PCT)

(19) World Intellectual Property
Organization
International Bureau(43) International Publication Date
15 March 2012 (15.03.2012)(10) International Publication Number
WO 2012/033638 A4

- (51) **International Patent Classification:**
E21B 34/06 (2006.01) *E21B 43/00* (2006.01)
- (21) **International Application Number:**
PCT/US2011/048986
- (22) **International Filing Date:**
24 August 2011 (24.08.2011)
- (25) **Filing Language:** English
- (26) **Publication Language:** English
- (30) **Priority Data:**
12/879,846 10 September 2010 (10.09.2010) US
- (71) **Applicant (for all designated States except US):** HAL-LIBURTON ENERGY SERVICES, INC. [US/US]; 10200 Bellaire Boulevard, Houston, TX 77072 (US).
- (72) **Inventor; and**
- (75) **Inventor/Applicant (for US only):** DYKSTRA, Jason, D. [US/US]; 2601 Beltline Road, Carrollton, TX 75006 (US).
- (74) **Agent:** SMITH, Marlin, R.; Smith IP Services, P.C., P.O. Box 997, Rockwall, TX 75087 (US).
- (81) **Designated States (unless otherwise indicated, for every kind of national protection available):** AE, AG, AL, AM, AO, AT, AU, AZ, BA, BB, BG, BH, BR, BW, BY, BZ, CA, CH, CL, CN, CO, CR, CU, CZ, DE, DK, DM, DO,

DZ, EC, EE, EG, ES, FI, GB, GD, GE, GH, GM, GT, HN, HR, HU, ID, IL, IN, IS, JP, KE, KG, KM, KN, KP, KR, KZ, LA, LC, LK, LR, LS, LT, LU, LY, MA, MD, ME, MG, MK, MN, MW, MX, MY, MZ, NA, NG, NI, NO, NZ, OM, PE, PG, PH, PL, PT, QA, RO, RS, RU, SC, SD, SE, SG, SK, SL, SM, ST, SV, SY, TH, TJ, TM, TN, TR, TT, TZ, UA, UG, US, UZ, VC, VN, ZA, ZM, ZW.

- (84) **Designated States (unless otherwise indicated, for every kind of regional protection available):** ARIPO (BW, GH, GM, KE, LR, LS, MW, MZ, NA, SD, SL, SZ, TZ, UG, ZM, ZW), Eurasian (AM, AZ, BY, KG, KZ, MD, RU, TJ, TM), European (AL, AT, BE, BG, CH, CY, CZ, DE, DK, EE, ES, FI, FR, GB, GR, HR, HU, IE, IS, IT, LT, LU, LV, MC, MK, MT, NL, NO, PL, PT, RO, RS, SE, SI, SK, SM, TR), OAPI (BF, BJ, CF, CG, CI, CM, GA, GN, GQ, GW, ML, MR, NE, SN, TD, TG).

Declarations under Rule 4.17:

- as to applicant's entitlement to apply for and be granted a patent (Rule 4.17(ii))

Published:

- with international search report (Art. 21(3))
- with amended claims (Art. 19(1))

[Continued on next page]

(54) **Title:** SERIES CONFIGURED VARIABLE FLOW RESTRICTORS FOR USE IN A SUBTERRANEAN WELL

FIG. 3A

(57) **Abstract:** A variable flow resistance system can include a vortex device, with resistance to flow of a fluid composition through the vortex device being dependent on a rotation of the fluid composition at an inlet to the vortex device. Another system can include a second vortex device which receives a fluid composition from an outlet of a first vortex device, a resistance to flow of the fluid composition through the second vortex device being dependent on a rotation of the fluid composition at the outlet. Another system can include a first vortex device which causes increased rotation of a fluid composition at an outlet thereof in response to an increase the fluid composition velocity, and a second vortex device which receives the fluid composition from the outlet, a flow resistance through the second vortex device being dependent on the rotation of the fluid composition at the outlet.

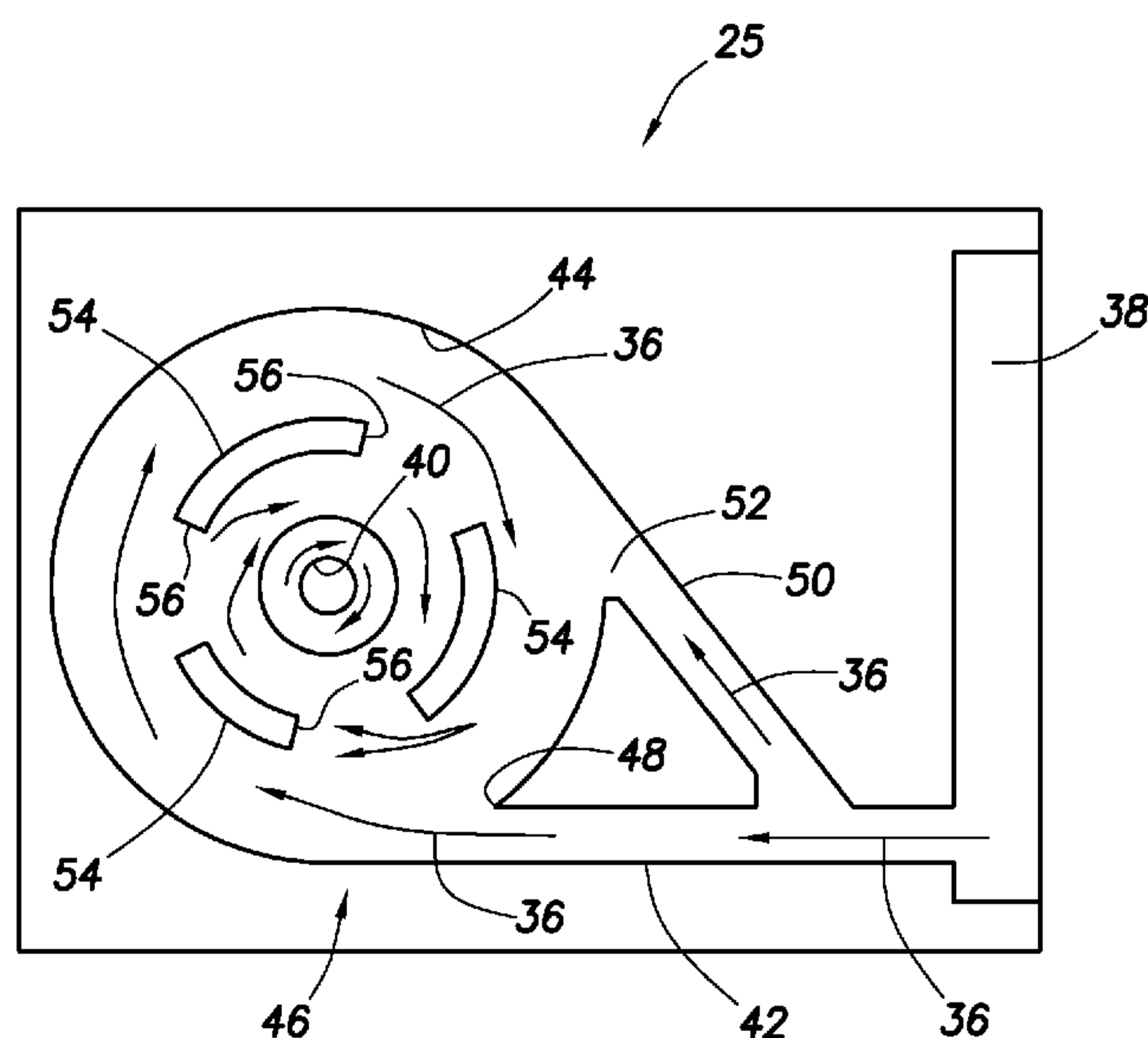

WO 2012/033638 A4

WO 2012/033638 A4 

(88) Date of publication of the international search report: 18 May 2012
Date of publication of the amended claims: 21 June 2012

- 1 -

5

**SERIES CONFIGURED VARIABLE FLOW RESTRICTORS FOR USE
IN A SUBTERRANEAN WELL**

10

TECHNICAL FIELD

This disclosure relates generally to equipment utilized and operations performed in conjunction with a subterranean well and, in an example described below, more particularly provides a series configuration of variable flow
15 restrictors.

BACKGROUND

In a hydrocarbon production well, it is many times beneficial to be able to regulate flow of fluids from an
20 earth formation into a wellbore. A variety of purposes may be served by such regulation, including prevention of water or gas coning, minimizing sand production, minimizing water and/or gas production, maximizing oil and/or gas production, balancing production among zones, etc.

25 In an injection well, it is typically desirable to evenly inject water, steam, gas, etc., into multiple zones, so that hydrocarbons are displaced evenly through an earth formation, without the injected fluid prematurely breaking through to a production wellbore. Thus, the ability to

- 2 -

regulate flow of fluids from a wellbore into an earth formation can also be beneficial for injection wells.

Therefore, it will be appreciated that advancements in the art of controlling fluid flow in a well would be
5 desirable in the circumstances mentioned above, and such advancements would also be beneficial in a wide variety of other circumstances.

10

SUMMARY

In the disclosure below, a variable flow resistance system is provided which brings improvements to the art of regulating fluid flow in wells. One example is described below in which resistance to flow through a vortex device is
15 dependent on a rotation of a fluid composition as it enters the vortex device. Another example is described, in which multiple vortex devices are connected in series.

In one aspect, the disclosure provides to the art a variable flow resistance system for use in a subterranean
20 well. The system can include a vortex device through which a fluid composition flows. A resistance to flow of the fluid composition through the vortex device is dependent on a rotation of the fluid composition at an inlet to the vortex device.

In another aspect, a variable flow resistance system
25 described below can include a first vortex device having an outlet, and a second vortex device which receives a fluid composition from the outlet of the first vortex device. A resistance to flow of the fluid composition through the
30 second vortex device is dependent on a rotation of the fluid composition at the outlet of the first vortex device.

- 3 -

In yet another aspect, a variable flow resistance system can include a first vortex device which causes increased rotation of a fluid composition at an outlet of the first vortex device in response to an increase in a velocity of the fluid composition, and a second vortex device which receives the fluid composition from the outlet of the first vortex device. A resistance to flow of the fluid composition through the second vortex device is dependent on the rotation of the fluid composition at the outlet of the first vortex device.

These and other features, advantages and benefits will become apparent to one of ordinary skill in the art upon careful consideration of the detailed description of representative examples below and the accompanying drawings, in which similar elements are indicated in the various figures using the same reference numbers.

BRIEF DESCRIPTION OF THE DRAWINGS

FIG. 1 is a schematic partially cross-sectional view of a well system which can embody principles of the present disclosure.

FIG. 2 is an enlarged scale schematic cross-sectional view of a well screen and a variable flow resistance system which may be used in the well system of FIG. 1.

FIGS. 3A & B are schematic "unrolled" cross-sectional views of one configuration of the variable flow resistance system, taken along line 3-3 of FIG. 2.

FIG. 4 is a schematic cross-sectional view of another configuration of the variable flow resistance system.

FIG. 5 is a schematic cross-sectional of the variable flow resistance system of FIG. 4, taken along line 5-5.

- 4 -

FIGS. 6A & B are schematic cross-sectional views the variable flow resistance system of FIG. 4, depicting changes in flow resistance resulting from changes in characteristics of a fluid composition.

5

DETAILED DESCRIPTION

Representatively illustrated in FIG. 1 is a well system 10 which can embody principles of this disclosure. As depicted in FIG. 1, a wellbore 12 has a generally vertical uncased section 14 extending downwardly from casing 16, as well as a generally horizontal uncased section 18 extending through an earth formation 20.

A tubular string 22 (such as a production tubing string) is installed in the wellbore 12. Interconnected in the tubular string 22 are multiple well screens 24, variable flow resistance systems 25 and packers 26.

The packers 26 seal off an annulus 28 formed radially between the tubular string 22 and the wellbore section 18. In this manner, fluids 30 may be produced from multiple intervals or zones of the formation 20 via isolated portions of the annulus 28 between adjacent pairs of the packers 26.

Positioned between each adjacent pair of the packers 26, a well screen 24 and a variable flow resistance system 25 are interconnected in the tubular string 22. The well screen 24 filters the fluids 30 flowing into the tubular string 22 from the annulus 28. The variable flow resistance system 25 variably restricts flow of the fluids 30 into the tubular string 22, based on certain characteristics of the fluids.

At this point, it should be noted that the well system 10 is illustrated in the drawings and is described herein as

- 5 -

merely one example of a wide variety of well systems in which the principles of this disclosure can be utilized. It should be clearly understood that the principles of this disclosure are not limited at all to any of the details of the well system 10, or components thereof, depicted in the drawings or described herein.

For example, it is not necessary in keeping with the principles of this disclosure for the wellbore 12 to include a generally vertical wellbore section 14 or a generally horizontal wellbore section 18. It is not necessary for fluids 30 to be only produced from the formation 20 since, in other examples, fluids could be injected into a formation, fluids could be both injected into and produced from a formation, etc.

It is not necessary for one each of the well screen 24 and variable flow resistance system 25 to be positioned between each adjacent pair of the packers 26. It is not necessary for a single variable flow resistance system 25 to be used in conjunction with a single well screen 24. Any number, arrangement and/or combination of these components may be used.

It is not necessary for any variable flow resistance system 25 to be used with a well screen 24. For example, in injection operations, the injected fluid could be flowed through a variable flow resistance system 25, without also flowing through a well screen 24.

It is not necessary for the well screens 24, variable flow resistance systems 25, packers 26 or any other components of the tubular string 22 to be positioned in uncased sections 14, 18 of the wellbore 12. Any section of the wellbore 12 may be cased or uncased, and any portion of the tubular string 22 may be positioned in an uncased or

- 6 -

cased section of the wellbore, in keeping with the principles of this disclosure.

It should be clearly understood, therefore, that this disclosure describes how to make and use certain examples, but the principles of the disclosure are not limited to any details of those examples. Instead, those principles can be applied to a variety of other examples using the knowledge obtained from this disclosure.

It will be appreciated by those skilled in the art that it would be beneficial to be able to regulate flow of the fluids into the tubular string 22 from each zone of the formation 20, for example, to prevent water coning 32 or gas coning 34 in the formation. Other uses for flow regulation in a well include, but are not limited to, balancing production from (or injection into) multiple zones, minimizing production or injection of undesired fluids, maximizing production or injection of desired fluids, etc.

Examples of the variable flow resistance systems described more fully below can provide these benefits by increasing resistance to flow if a fluid velocity increases beyond a selected level (e.g., to thereby balance flow among zones, prevent water or gas coning, etc.), and/or increasing resistance to flow if a fluid viscosity decreases below a selected level (e.g., to thereby restrict flow of an undesired fluid, such as water or gas, in an oil producing well).

As used herein, the term "viscosity" is used to indicate any of the rheological properties including kinematic viscosity, yield strength, viscoplasticity, surface tension, wettability, etc.

Whether a fluid is a desired or an undesired fluid depends on the purpose of the production or injection

- 7 -

operation being conducted. For example, if it is desired to produce oil from a well, but not to produce water or gas, then oil is a desired fluid and water and gas are undesired fluids. If it is desired to produce gas from a well, but
5 not to produce water or oil, the gas is a desired fluid, and water and oil are undesired fluids. If it is desired to inject steam into a formation, but not to inject water, then steam is a desired fluid and water is an undesired fluid.

If gas is being flowed, it can be difficult to restrict
10 flow of the gas using conventional techniques, which typically involve interposing small diameter passages, orifices, etc. in the gas flow. Unfortunately, these devices can have an increased volumetric flow rate when gas is flowing instead of oil or another fluid, and can result
15 in erosion problems.

Note that, at downhole temperatures and pressures, hydrocarbon gas can actually be completely or partially in liquid phase. Thus, it should be understood that when the term "gas" is used herein, supercritical, liquid, condensate
20 and/or gaseous phases are included within the scope of that term.

Referring additionally now to FIG. 2, an enlarged scale cross-sectional view of one of the variable flow resistance systems 25 and a portion of one of the well screens 24 is
25 representatively illustrated. In this example, a fluid composition 36 (which can include one or more fluids, such as oil and water, liquid water and steam, oil and gas, gas and water, oil, water and gas, etc.) flows into the well screen 24, is thereby filtered, and then flows into an inlet
30 38 of the variable flow resistance system 25.

A fluid composition can include one or more undesired or desired fluids. Both steam and water can be combined in

- 8 -

a fluid composition. As another example, oil, water and/or gas can be combined in a fluid composition.

Flow of the fluid composition 36 through the variable flow resistance system 25 is resisted based on one or more characteristics (such as viscosity, velocity, etc.) of the fluid composition. The fluid composition 36 is then discharged from the variable flow resistance system 25 to an interior of the tubular string 22 via an outlet 40.

In other examples, the well screen 24 may not be used in conjunction with the variable flow resistance system 25 (e.g., in injection operations), the fluid composition 36 could flow in an opposite direction through the various elements of the well system 10 (e.g., in injection operations), a single variable flow resistance system could be used in conjunction with multiple well screens, multiple variable flow resistance systems could be used with one or more well screens, the fluid composition could be received from or discharged into regions of a well other than an annulus or a tubular string, the fluid composition could flow through the variable flow resistance system prior to flowing through the well screen, any other components could be interconnected upstream or downstream of the well screen and/or variable flow resistance system, etc. Thus, it will be appreciated that the principles of this disclosure are not limited at all to the details of the example depicted in FIG. 2 and described herein.

Although the well screen 24 depicted in FIG. 2 is of the type known to those skilled in the art as a wire-wrapped well screen, any other types or combinations of well screens (such as sintered, expanded, pre-packed, wire mesh, etc.) may be used in other examples. Additional components (such

- 9 -

as shrouds, shunt tubes, lines, instrumentation, sensors, inflow control devices, etc.) may also be used, if desired.

The variable flow resistance system 25 is depicted in simplified form in FIG. 2, but in a preferred example the system can include various passages and devices for performing various functions, as described more fully below. In addition, the system 25 can at least partially extend circumferentially about the tubular string 22, or the system may be formed in a wall of a tubular structure interconnected as part of the tubular string.

In other examples, the system 25 may not extend circumferentially about a tubular string or be formed in a wall of a tubular structure. For example, the system 25 could be formed in a flat structure, etc. The system 25 could be in a separate housing that is attached to the tubular string 22, or it could be oriented so that the axis of the outlet 40 is parallel to the axis of the tubular string. The system 25 could be on a logging string or attached to a device that is not tubular in shape. Any orientation or configuration of the system 25 may be used in keeping with the principles of this disclosure.

Referring additionally now to FIGS. 3A & B, a more detailed cross-sectional view of one example of the system 25 is representatively illustrated. The system 25 is depicted in FIGS. 3A & B as if it is "unrolled" from its circumferentially extending configuration to a generally planar configuration.

As described above, the fluid composition 36 enters the system 25 via the inlet 38, and exits the system via the outlet 40. A resistance to flow of the fluid composition 36 through the system 25 varies based on one or more characteristics of the fluid composition.

- 10 -

The inlet 38, the outlet 40, and a flow passage 42 and flow chamber 44 through which the fluid composition 36 flows between the inlet and the outlet, are elements of a vortex device 46 which restricts flow of the fluid composition based on certain characteristics of the fluid composition. Rotational flow of the fluid composition 36 increases in the chamber 44, thereby increasing restriction to flow through the chamber, for example, when a velocity of the fluid composition increases, when a viscosity of the fluid composition decreases and/or when a ratio of desired fluid to undesired fluid in the fluid composition decreases.

As depicted in FIG. 3A, the chamber 44 is generally cylindrical-shaped, and the flow passage 42 intersects the chamber tangentially, so that fluid entering the chamber via the inlet 48 tends to flow clockwise (as viewed in FIG. 3A) about the outlet 40. A bypass passage 50 intersects the passage 42 downstream of the inlet 38, and the bypass passage also intersects the chamber 44 tangentially. However, fluid entering the chamber 44 through the bypass passage 50 via an inlet 52 tends to flow counterclockwise (as viewed in FIG. 3A) about the outlet 40.

In FIG. 3A, a relatively high velocity and/or low viscosity fluid composition 36 flows through the flow passage 42 from the system inlet 38 to the flow chamber 44. In contrast, a relatively low velocity and/or high viscosity fluid composition 36 flows through the flow passage 42 to the chamber 44 in FIG. 3B.

Only a small proportion of the fluid composition 36 flows to the chamber 44 via the bypass passage 50 in FIG. 3A. Thus, a substantial proportion of the fluid composition 36 rotates in the chamber 44, spiraling with increasing rotational velocity toward the outlet 40. Note that the

- 11 -

rotation of the fluid composition 36 at the outlet 40 will increase as the velocity of the fluid composition entering the inlet 38 increases, and as a viscosity of the fluid composition decreases.

5 A substantially larger proportion of the fluid composition flows to the chamber 44 via the bypass passage 50 in FIG. 3B. In this example, the flows entering the chamber 44 via the inlets 48, 52 are about equal. These flows effectively "cancel" or counteract each other, so that
10 there is relatively little rotational flow of the fluid composition 36 in the chamber 44.

It will be appreciated that the much more circuitous flow path taken by the fluid composition 36 in the example of FIG. 3A consumes more of the fluid composition's energy
15 at the same flow rate and, thus, results in more resistance to flow, as compared to the much more direct flow path taken by the fluid composition in the example of FIG. 3B. If oil is a desired fluid, and water and/or gas are undesired fluids, then it will be appreciated that the variable flow
20 resistance system 25 of FIGS. 3A & B will provide less resistance to flow of the fluid composition 36 when it has an increased ratio of desired to undesired fluid therein, and will provide greater resistance to flow when the fluid composition has a decreased ratio of desired to undesired
25 fluid therein.

Since the chamber 44 in this example has a cylindrical shape with a central outlet 40, and the fluid composition 36 (at least in FIG. 3A) spirals about the chamber, increasing in velocity as it nears the outlet, driven by a pressure
30 differential from the inlet 44 to the outlet, the chamber may be referred to as a "vortex" chamber.

- 12 -

Circular flow inducing structures 54 are used in the chamber 44 in the configuration of FIGS. 3A & B. The structures 54 operate to maintain circular flow of the fluid composition 36 about the outlet 40, or at least to impede inward flow of the fluid composition toward the outlet, when the fluid composition does flow circularly about the outlet. Openings 56 in the structures 54 permit the fluid composition 36 to eventually flow inward to the outlet 40.

As discussed above, in FIG. 3A, the vortex device 46 is depicted in a situation in which an increased velocity and/or reduced viscosity of the fluid composition 36 results in a substantial proportion of the fluid composition flowing into the chamber 44 via the inlet 48. The fluid composition 36, thus, spirals about the outlet 40 in the chamber 44, and a resistance to flow through the vortex device 46 increases. A reduced viscosity can be due to a relatively low ratio of desired fluid to undesired fluid in the fluid composition 36.

Relatively little of the fluid composition 36 flows into the chamber 44 via the inlet 52 in FIG. 3A, because the flow passage 50 is branched from the flow passage 42 in a manner such that most of the fluid composition remains in the flow passage 42. At relatively high velocities and/or low viscosities, the fluid composition 36 tends to flow past the flow passage 50.

In FIG. 3B, a velocity of the fluid composition 36 has decreased and/or a viscosity of the fluid composition has increased, and as a result, proportionately more of the fluid composition flows from the passage 42 and via the passage 50 to the inlet 52. The increased viscosity of the fluid composition 36 may be due to an increased ratio of desired to undesired fluids in the fluid composition.

- 13 -

Since, in FIG. 3B, the flows into the chamber 44 from the two inlets 48, 52 are oppositely directed (or at least the flow of the fluid composition through the inlet 52 opposes the flow through the inlet 48), they counteract each other. Thus, the fluid composition 36 flows more directly to the outlet 40 and a resistance to flow through the vortex device 46 is decreased, and the fluid composition has reduced (or no) rotation at the outlet 40.

Referring additionally now to FIG. 4, another configuration of the variable flow resistance system 25 is representatively illustrated. In this configuration, the vortex device 46 is used in series with two additional vortex devices 58, 60. Although three vortex devices 46, 58, 60 are depicted in FIG. 4, it will be appreciated that any number of vortex devices may be connected in series, in keeping with the principles of this disclosure.

An outlet 62 of the vortex device 46 corresponds to an inlet of the vortex device 58, and an outlet 64 of the vortex device 58 corresponds to an inlet of the vortex device 60. The fluid composition 36 flows from the system 25 inlet 38 to the chamber 44, from the chamber 44 to the vortex device 58 via the outlet/inlet 62, from the outlet/inlet 62 to a vortex chamber 66 of the vortex device 58, from the chamber 66 to the vortex device 60 via the outlet/inlet 64, from the outlet/inlet 64 to a vortex chamber 68 of the vortex device 60, and from the chamber 68 to the outlet 40 of the system 25.

Each of the vortex devices 58, 60 includes two passages 70, 72 and 74, 76, respectively, which function somewhat similar to the passages 42, 50 of the vortex device 46. However, the proportions of the fluid composition 36 which flows through each of the passages 70, 72 and 74, 76 varies

- 14 -

based on a rotation of the fluid composition as it enters the respective vortex device 58, 60, as described more fully below.

Referring additionally now to FIG. 5, a cross-sectional view of the variable flow resistance system 25 is representatively illustrated, as viewed along line 5-5 of FIG. 4. In this view, the manner in which the outlet/inlet 62 and outlet/inlet 64 provide fluid communication between the vortex devices 46, 58, 60 can be readily seen.

In FIG. 5, it may also be seen that the vortex devices 46, 58, 60 are "stacked" in a compact manner, alternating orientation back and forth. However, it will be appreciated that the vortex devices 46, 58, 60 could be otherwise arranged, in keeping with the principles of this disclosure.

Referring additionally now to FIGS. 6A & B, the variable flow resistance system 25 of FIGS. 4 & 5 is depicted, with a relatively low viscosity and/or high velocity fluid composition 36 flowing through the system in FIG. 6A, and with a relatively high viscosity and/or low velocity fluid composition flowing through the system in FIG. 6B. These examples demonstrate how the resistance to flow through the system 25 varies based on certain characteristics of the fluid composition 36.

In FIG. 6A, significant spiraling flow of the fluid composition 36 is present in the vortex device 46 (similar to that described above in relation to FIG. 3A). As a result, the fluid composition 36 is rotating significantly when it flows from the chamber 44 to the vortex device 58 via the outlet/inlet 62.

This rotational flow of the fluid composition 36 causes a greater proportion of the fluid composition to flow through the passage 70, as compared to the proportion of the

- 15 -

fluid composition which flows through the passage 72. The manner in which the rotating fluid composition 36 impinges on the curved walls of the passages 70, 72 at their intersection with the outlet/inlet 62 causes this difference
5 in the proportions of the fluid composition which flows through each of the passages.

Since a greater proportion of the fluid composition 36 flows into the chamber 66 of the vortex device 58 via the passage 70, the fluid composition rotates within the chamber
10 66, similar to the manner in which the fluid composition flows spirally through the chamber 44 of the vortex device 46. This spiraling flow of the fluid composition 36 through the chamber 66 generates resistance to flow, with the resistance to flow increasing with increased rotational flow
15 of the fluid composition in the chamber.

The fluid composition 36 rotates as it exits the chamber 66 via the outlet/inlet 64. This rotational flow of the fluid composition 36 causes a greater proportion of the fluid composition to flow through the passage 74, as
20 compared to the proportion of the fluid composition which flows through the passage 76. Similar to that described above for the vortex chamber 58, the manner in which the rotating fluid composition 36 impinges on the curved walls of the passages 74, 76 at their intersection with the
25 outlet/inlet 64 causes this difference in the proportions of the fluid composition which flows through each of the passages.

Since a greater proportion of the fluid composition 36 flows into the chamber 68 of the vortex device 60 via the
30 passage 74, the fluid composition rotates within the chamber 68, similar to the manner in which the fluid composition flows spirally through the chamber 66 of the vortex device

- 16 -

58. This spiraling flow of the fluid composition 36 through the chamber 68 generates resistance to flow, with the resistance to flow increasing with increased rotational flow of the fluid composition in the chamber.

5 Thus, with the relatively high velocity and/or low viscosity fluid composition 36 in FIG. 6A, rotational flow and resistance to flow is increased in each of the vortex devices 46, 58, 60, so that overall flow resistance is much greater than that which would have been provided by only the
10 single vortex device 46. In addition, the rotational flow through the chambers 66, 68 of the vortex devices 58, 60 is due to the rotational flow of the fluid composition 36 at each of the outlet/inlets 62, 64.

In FIG. 6B, a relatively high viscosity and/or low
15 velocity fluid composition 36 flows through the system 25. Note that rotational flow of the fluid composition 36 in each of the chambers 44, 66, 68 is significantly reduced, and so the resistance to flow of the fluid composition through the chambers is also significantly reduced. Thus,
20 the resistance to flow of the relatively high viscosity and/or low velocity fluid composition 36 is much less in FIG. 6B, as compared to the resistance to flow of the relatively low viscosity and/or high velocity fluid composition in FIG. 6A.

25 Note that any of the features of any of the configurations of the system 25 described above may be included in any of the other configurations of the system and, thus, it should be understood that these features are not exclusive to any one particular configuration of the
30 system. The system 25 can be used in any type of well system (e.g., not only in the well system 10), and for accomplishing various purposes in various well operations,

- 17 -

including but not limited to injection, stimulation, completion, production, conformance, drilling operations, etc.

It will be appreciated that the system 25 of FIGS. 4-6B provides significant advancements to the art of controlling flow in a well. The resistance to flow of the fluid composition 36 through the system 25 can be substantially increased by connecting the vortex devices 46, 58, 60 in series, and by resisting flow of the fluid composition in response to its rotation as it passes from one vortex device to the next.

The above disclosure provides to the art a variable flow resistance system 25 for use in a subterranean well. The system 25 can include a vortex device 58 or 60 through which a fluid composition 36 flows. A resistance to flow of the fluid composition 36 through the vortex device 58 or 60 is dependent on a rotation of the fluid composition 36 at an inlet 62 or 64 to the vortex device 58 or 60.

The resistance to flow of the fluid composition 36 through the vortex device 58 or 60 can increase in response to an increased rotation of the fluid composition 36 at the inlet 62 or 64 to the vortex device 58 or 60.

The rotation of the fluid composition 36 at the inlet 62 or 64 can increase in response to a decrease in viscosity of the fluid composition 36.

The rotation of the fluid composition 36 at the inlet 62 or 64 can increase in response to an increase in velocity of the fluid composition 36.

The rotation of the fluid composition 36 at the inlet 62 or 64 can increase in response to a decrease in a ratio of desired to undesired fluid in the fluid composition 36.

- 18 -

An outlet 64 of the vortex device 58 can comprise an inlet 64 of another vortex device 60. The inlet 64 of the vortex device 60 can comprise an outlet 64 of another vortex device 58.

5 The vortex device 58 can comprise at least first and second passages 70, 72 which receive the fluid composition 36 from an outlet 62 of another vortex device 46. A difference in proportions of the fluid composition 36 which flows through the respective first and second passages 70,
10 72 is dependent on the rotation of the fluid composition 36 at the outlet 62. The difference in the proportions of the fluid composition 36 which flows through the first and second passages 70, 72 may increase in response to an increase in velocity of the fluid composition 36.

15 Rotation of the fluid composition 36 in a vortex chamber 66 increases in response to an increase in the difference in the proportions of the fluid composition 36 which flows through the first and second passages 70, 72.

20 The above disclosure also describes a variable flow resistance system 25 which can include a first vortex 46 device having an outlet 62, and a second vortex device 58 which receives a fluid composition 36 from the outlet 62 of the first vortex device 46. A resistance to flow of the fluid composition 36 through the second vortex device 58 can
25 be dependent on a rotation of the fluid composition 36 at the outlet 62 of the first vortex device 46.

30 The rotation of the fluid composition 36 at the outlet 62 may increase in response to a decrease in viscosity of the fluid composition 36, in response to an increase in velocity of the fluid composition 36 and/or in response to a decrease in a ratio of desired to undesired fluid in the fluid composition 36.

- 19 -

The resistance to flow of the fluid composition 36 through the second vortex device 58 can increase in response to an increase in the rotation of the fluid composition 36 at the outlet 62 of the first vortex device 46.

5 An outlet 64 of the second vortex device 58 can comprise an inlet 64 of a third vortex device 60.

The second vortex device 58 can include at least first and second passages 70, 72 which receive the fluid composition 36 from the outlet 62 of the first vortex device
10 46. A difference in proportions of the fluid composition 36 which flow through the respective first and second passages 70, 72 is dependent on the rotation of the fluid composition 36 at the outlet 62 of the first vortex device 46.

The difference in the proportions of the fluid
15 composition 36 which flows through the first and second passages 70, 72 may increase in response to an increase in velocity of the fluid composition 36.

Rotation of the fluid composition 36 in a vortex chamber 66 of the second vortex device 58 may increase in
20 response to an increase in the difference in the proportions of the fluid composition 36 which flows through the first and second passages 70, 72.

The above disclosure also describes a variable flow resistance system 25 which can include a first vortex device
25 46 which causes increased rotation of a fluid composition 36 at an outlet 62 of the first vortex device 46 in response to an increase in a velocity of the fluid composition 36, and a second vortex device 58 which receives the fluid composition 36 from the outlet 62 of the first vortex device 46. A
30 resistance to flow of the fluid composition 36 through the second vortex device 58 may be dependent on the rotation of

- 20 -

the fluid composition 36 at the outlet 62 of the first vortex device 46.

It is to be understood that the various examples described above may be utilized in various orientations, such as inclined, inverted, horizontal, vertical, etc., and in various configurations, without departing from the principles of the present disclosure. The embodiments illustrated in the drawings are depicted and described merely as examples of useful applications of the principles of the disclosure, which are not limited to any specific details of these embodiments.

Of course, a person skilled in the art would, upon a careful consideration of the above description of representative embodiments, readily appreciate that many modifications, additions, substitutions, deletions, and other changes may be made to these specific embodiments, and such changes are within the scope of the principles of the present disclosure. Accordingly, the foregoing detailed description is to be clearly understood as being given by way of illustration and example only, the scope of the present invention being limited solely by the appended claims.

CLAIMS:

1. A variable flow resistance system for use in a subterranean well, the system comprising:
 - a vortex device through which a fluid composition flows, the vortex device including an inlet which is connected to a vortex chamber by at least two passages; and
 - a resistance to flow of the fluid composition through the vortex device is dependent on a rotation of the fluid composition at the inlet to the vortex device.
2. The system of claim 1, wherein an outlet of the vortex device comprises an inlet of another vortex device.
3. The system of claim 1, wherein the at least two passages comprise first and second passages which receive the fluid composition from an outlet of another vortex device, and wherein a difference in proportions of the fluid composition which flows through the respective first and second passages is dependent on the rotation of the fluid composition at the outlet.
4. The system of claim 3, wherein the difference in the proportions of the fluid composition which flows through the first and second passages increases in response to an increase in velocity of the fluid composition.
5. The system of claim 3, wherein a rotation of the fluid composition in the vortex chamber increases in response to an increase in the difference in the proportions of the fluid composition which flows through the first and second passages.
6. A variable flow resistance system for use in a subterranean well, the system comprising:
 - a first vortex device having an outlet; and
 - a second vortex device which receives a fluid composition from the outlet of the first vortex device via an inlet which is connected to a vortex chamber by at least two

- 22 -

passages, a resistance to flow of the fluid composition through the second vortex device being dependent on a rotation of the fluid composition at the outlet of the first vortex device.

7. The system of claim 6, wherein an outlet of the second vortex device comprises an inlet of a third vortex device.

8. The system of claim 6, wherein the at least two passages comprise first and second passages which receive the fluid composition from the outlet of the first vortex device, and wherein a difference in proportions of the fluid composition which flows through the respective first and second passages is dependent on the rotation of the fluid composition at the outlet of the first vortex device.

9. The system of claim 8, wherein the difference in the proportions of the fluid composition which flows through the first and second passages increases in response to an increase in velocity of the fluid composition.

10. The system of claim 8, wherein a rotation of the fluid composition in the vortex chamber of the second vortex device increases in response to an increase in the difference in the proportions of the fluid composition which flows through the first and second passages.

+

1/7

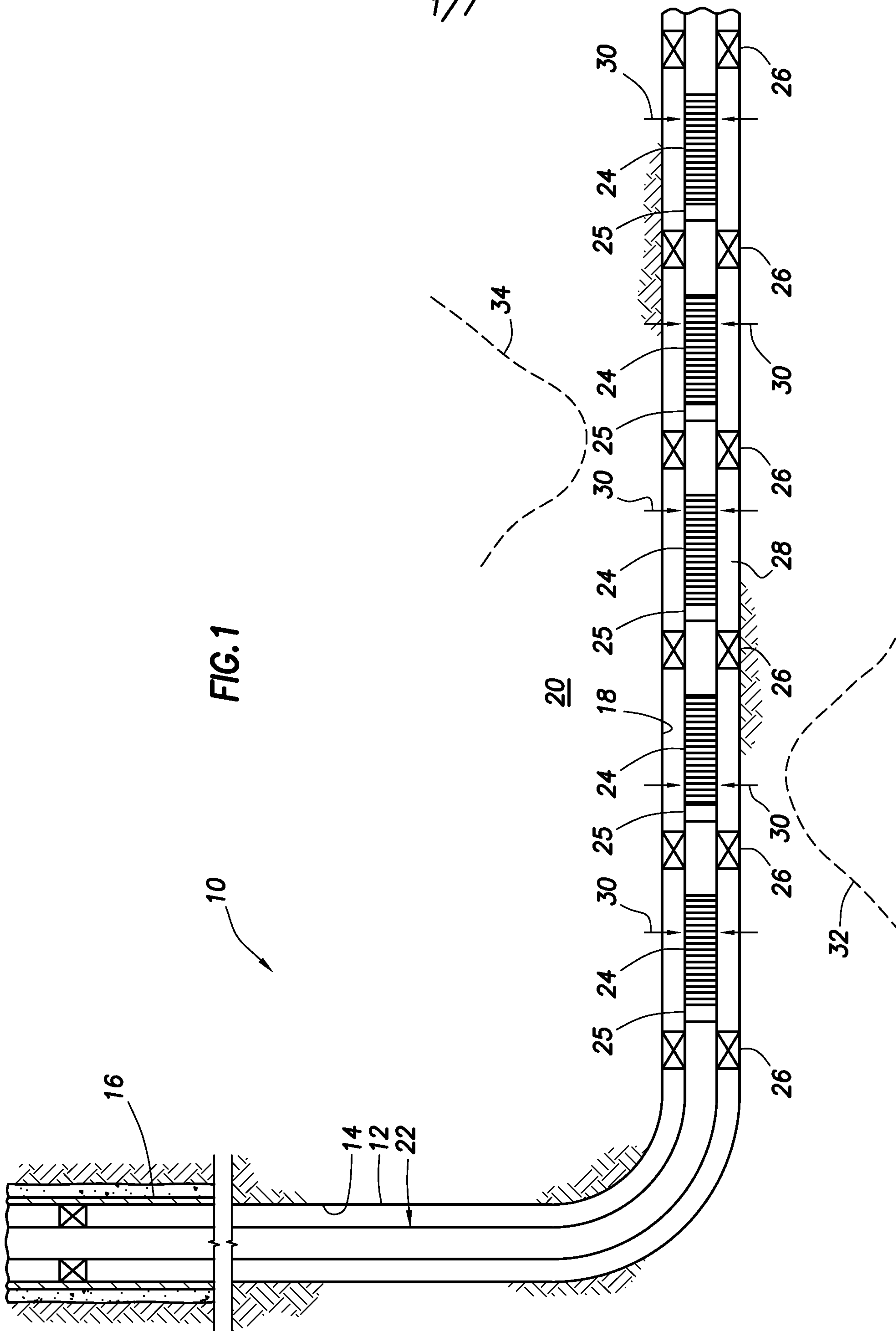

+

+

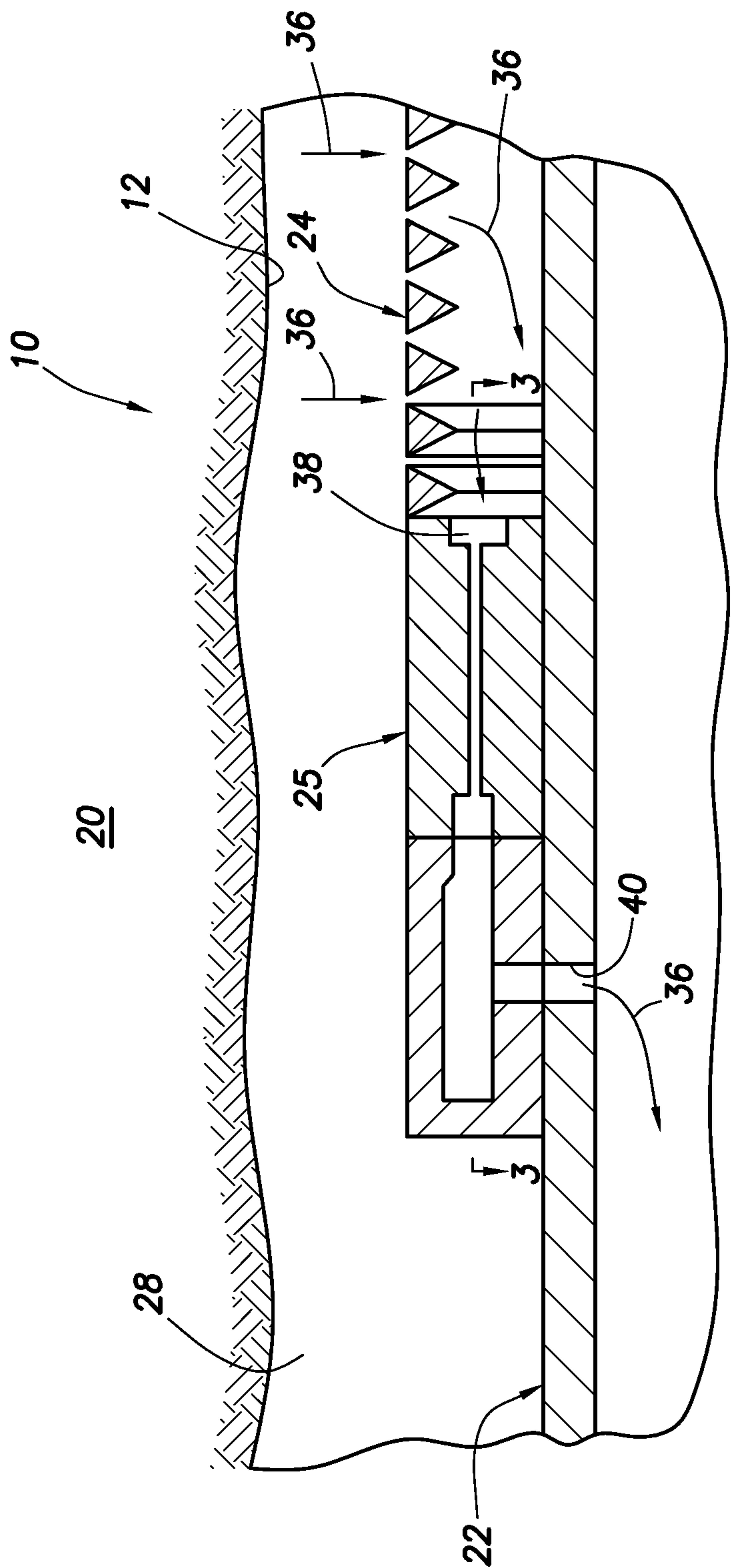

FIG.2

+

+

3/7

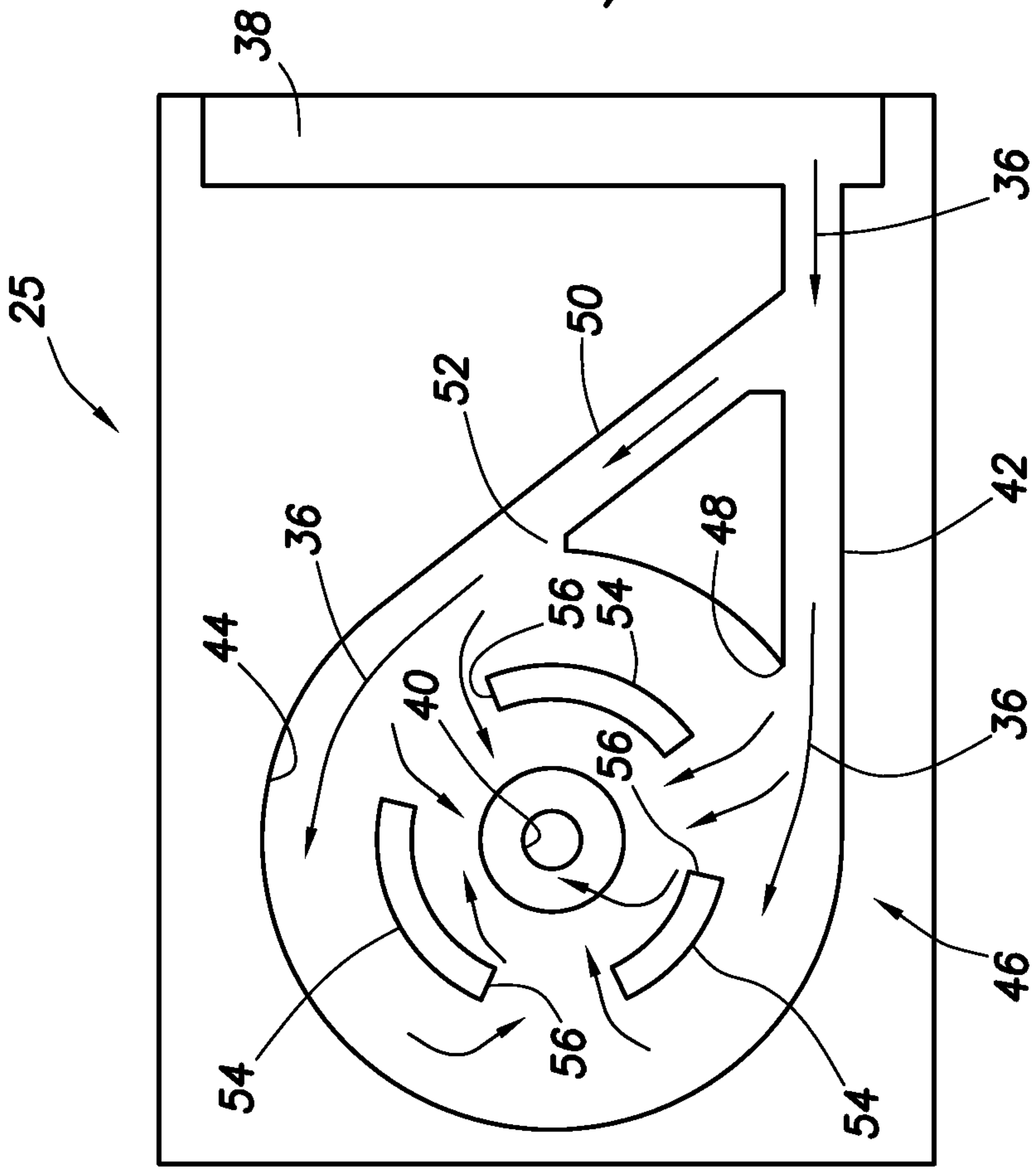

FIG. 3A

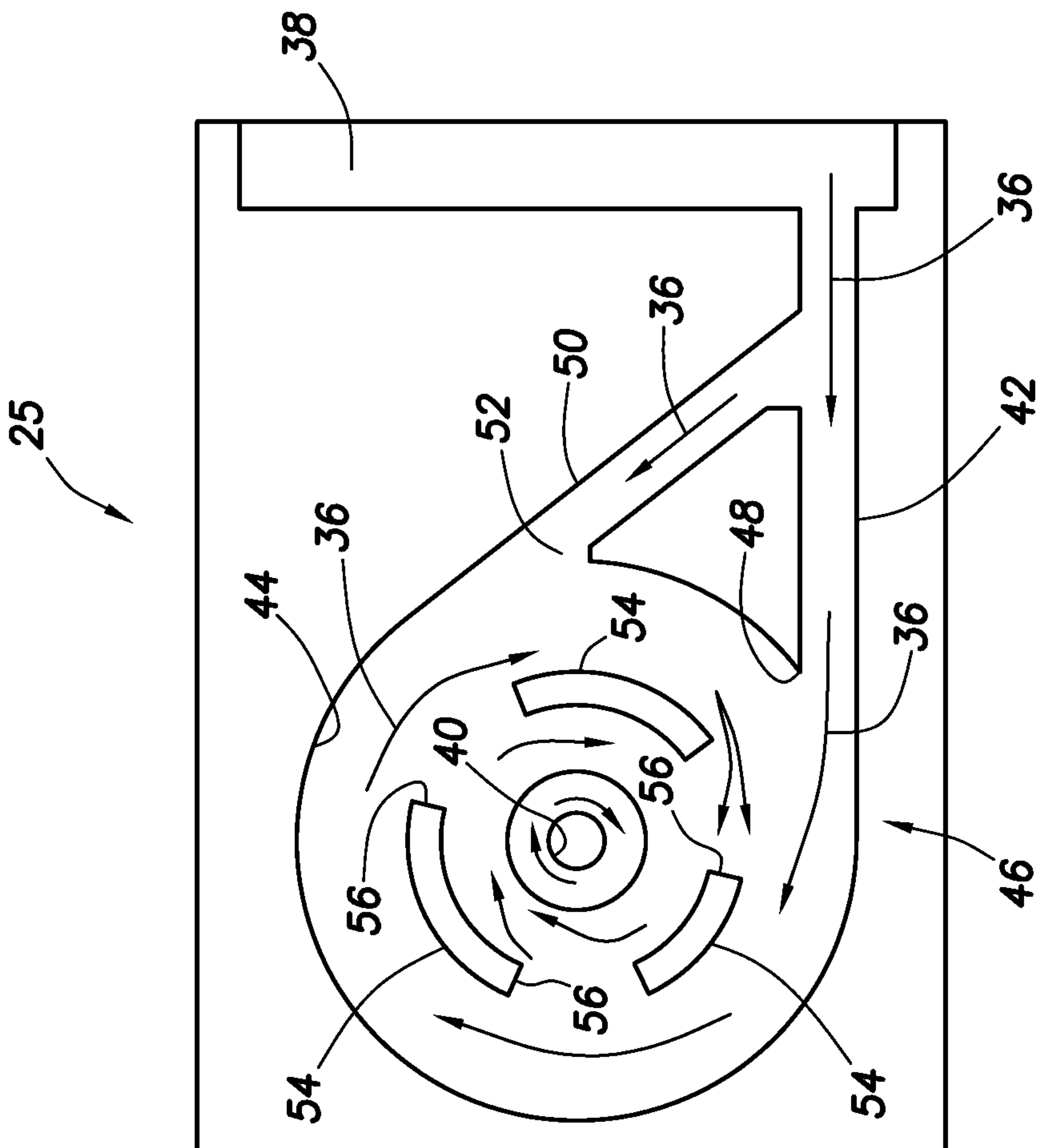

FIG. 3B

+

+

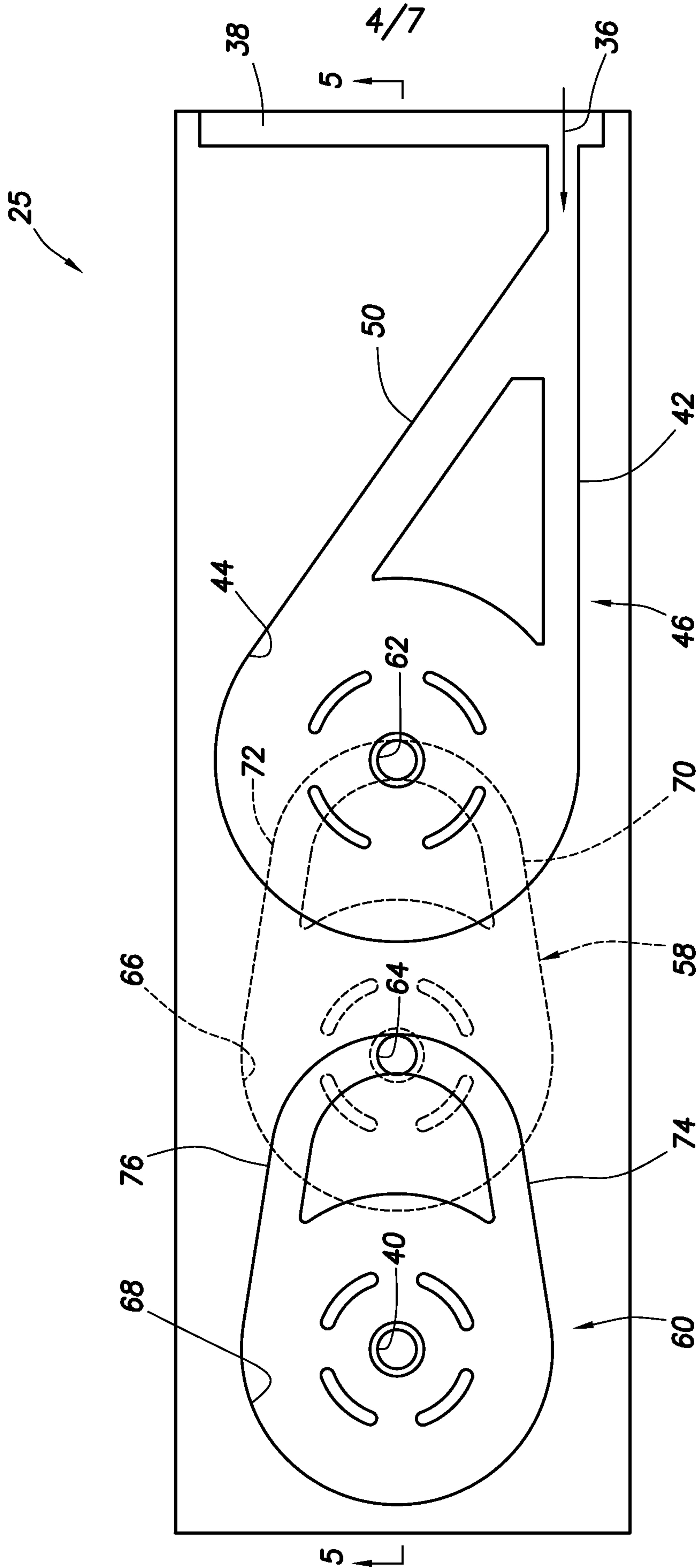

FIG. 4

+

+

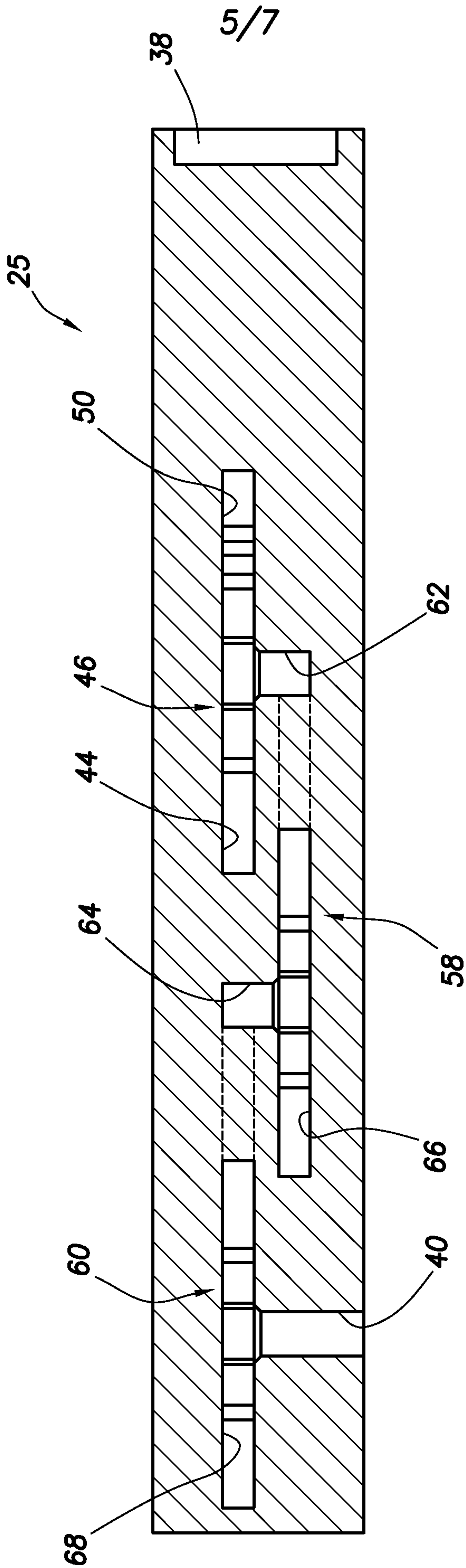

FIG.5

+

+

7/7

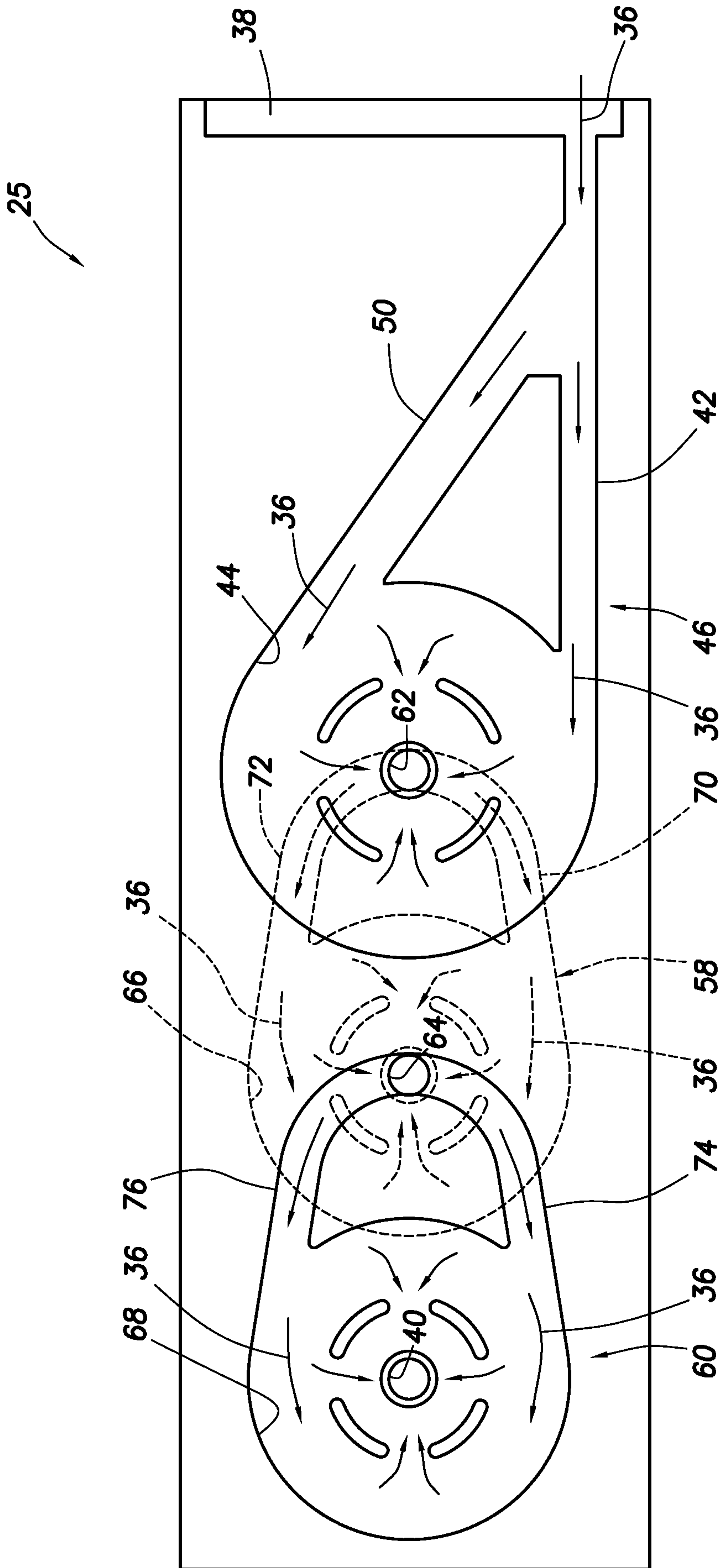

FIG. 6B

+

