



- (51) International Patent Classification:
B02C 15/12 (2006.01)
- (21) International Application Number:
PCT/IB2010/053752
- (22) International Filing Date:
19 August 2010 (19.08.2010)
- (25) Filing Language: English
- (26) Publication Language: English
- (30) Priority Data:
2009/05901 25 August 2009 (25.08.2009) ZA
- (72) Inventor; and
(71) Applicant : BARNARD, Tjaart, Johannes [ZA/ZA]; 29
Keurboom Avenue, Geelhoutpark Ext. 4, 0299 Rusten-
burg (ZA).
- (74) Agents: WELTHAGEN, Dieter, Hein et al.; Adams &
Adams, Adams & Adams Place, 1140 Prospect Street,
Hatfield, P O Box 1014, 0001 Pretoria (ZA).

- (81) Designated States (unless otherwise indicated, for every
kind of national protection available): AE, AG, AL, AM,
AO, AT, AU, AZ, BA, BB, BG, BH, BR, BW, BY, BZ,
CA, CH, CL, CN, CO, CR, CU, CZ, DE, DK, DM, DO,
DZ, EC, EE, EG, ES, FI, GB, GD, GE, GH, GM, GT,
HN, HR, HU, ID, IL, IN, IS, JP, KE, KG, KM, KN, KP,
KR, KZ, LA, LC, LK, LR, LS, LT, LU, LY, MA, MD,
ME, MG, MK, MN, MW, MX, MY, MZ, NA, NG, NI,
NO, NZ, OM, PE, PG, PH, PL, PT, RO, RS, RU, SC, SD,
SE, SG, SK, SL, SM, ST, SV, SY, TH, TJ, TM, TN, TR,
TT, TZ, UA, UG, US, UZ, VC, VN, ZA, ZM, ZW.
- (84) Designated States (unless otherwise indicated, for every
kind of regional protection available): ARIPO (BW, GH,
GM, KE, LR, LS, MW, MZ, NA, SD, SL, SZ, TZ, UG,
ZM, ZW), Eurasian (AM, AZ, BY, KG, KZ, MD, RU, TJ,
TM), European (AL, AT, BE, BG, CH, CY, CZ, DE, DK,
EE, ES, FI, FR, GB, GR, HR, HU, IE, IS, IT, LT, LU,
LV, MC, MK, MT, NL, NO, PL, PT, RO, SE, SI, SK,
SM, TR), OAPI (BF, BJ, CF, CG, CI, CM, GA, GN, GQ,
GW, ML, MR, NE, SN, TD, TG).

Declarations under Rule 4.17:

[Continued on next page]

(54) Title: DIMINUTION OF PARTICULATE MATERIAL

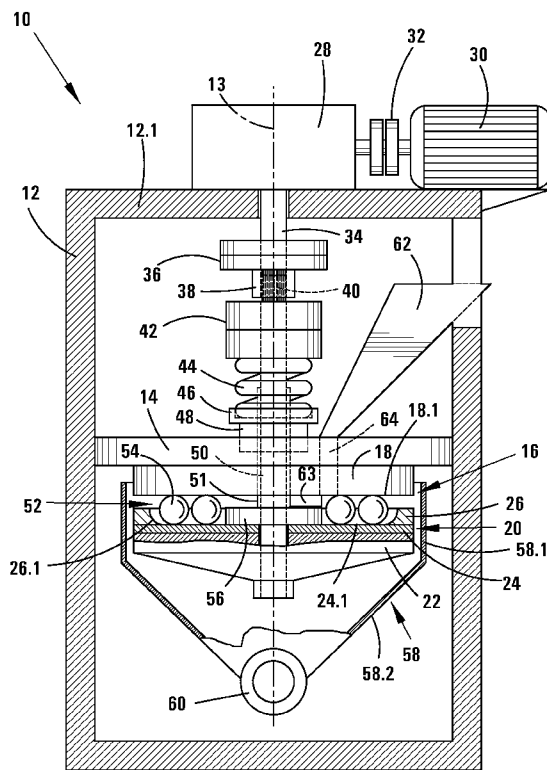

FIG. 1

(57) Abstract: This invention relates to a method of, and to a diminution apparatus for, diminuting particulate material. The apparatus includes an upper disc-like element and a lower disc-like element that are superimposed and spaced apart to provide a milling zone therebetween and drive means for effecting relative rotation of the disc-like elements. It includes also roller milling elements in the milling zone. In accordance with the method, particulate material, for example ore, is introduced into the milling zone and exposed to milling action in the milling zone. Once diminuted, the material is discharged via a peripheral outlet out of the milling zone.

WO 2011/024108 A2

- *as to the identity of the inventor (Rule 4.17(i))*
- *of inventorship (Rule 4.17(iv))*

Published:

- *without international search report and to be republished upon receipt of that report (Rule 48.2(g))*

DIMINUTION OF PARTICULATE MATERIAL

THIS INVENTION relates to diminution of particulate material. It relates more
5 specifically to a method of, and to a diminution apparatus for, diminishing particulate
material.

The Applicant expects this invention to be used especially in ore dressing, and this
10 application will particularly be born in mind for purposes of this specification.

Furthermore, diminution is to be interpreted as a combination of crushing and milling.
For convenience, the term milling will mostly be used and is to be interpreted, where the
context allows, as crushing followed by milling.

15 According to one aspect of the invention there is provided a method of diminishing
particulate material, the method including:

effecting relative rotation of a pair of superimposed disc-like elements which are
axially spaced to provide a milling zone therebetween and having roller milling elements
in the milling zone;

20 introducing the particulate material into the milling zone;
exposing the particulate material to milling action in the milling zone; and
discharging diminished material via a peripheral outlet out of the milling zone.

The method may include introducing the particulate material into the milling zone at a
25 position spaced from an outer periphery of the milling zone.

The relative rotation of the disc-like elements may be effected about a common, vertical
rotation axis.

30 The relative rotation of the disc-like elements may be effected by holding one of the
disc-like elements, which will then be a stator, stationary and rotating the other disc-like
element, which will then be a rotor. Alternatively, the relative rotation of the disc-like
elements may be effected by counter-rotating them.

The method may include urging one of the disc-like elements toward the other, thereby applying compression to material in the milling zone.

5 The method may include using centrifugal effect on account of rotation on the milling elements and the particulate material being milled to bias the milling elements outwardly and to move the particulate material outwardly. The method may include limiting outward movement of the milling elements beyond a predetermined boundary by means of a peripheral wall, and allowing diminished material to spill over the wall to enable the diminished material to be collected.

10

According to a second aspect of the invention there is provided a diminution apparatus suitable for use in diminuting particulate material, the apparatus including:

an upper disc-like element and a lower disc-like element that are superimposed and spaced apart to provide a milling zone therebetween;

15

drive means for effecting relative rotation of the disc-like elements;

roller milling elements in the milling zone;

an inlet for introducing particulate material into the milling zone; and

an outlet for discharging diminished material from the milling zone.

20

In the apparatus, the disc-like elements may be mounted co-axially about a common, vertical rotation axis.

The apparatus may include drive means for rotating one of the disc-like elements, which will then be a rotor, the other disc-like element, which will then be a stator, being held irrotationally. Alternatively, the apparatus may include drive means for counter-rotating the disc-like elements.

25

In the apparatus, the lower disc-like element may have a recessed upper surface for holding the milling elements and particulate material. The lower disc-like element may have a generally flat upper surface and a peripheral wall rendering it recessed, the wall retaining the milling elements within the milling zone and allowing diminished material to be discharged over it. A peripheral inner corner formation between the flat upper surface and a radially inner surface of the wall may be rounded. The roller milling

30

elements may be spherical and of the same size and the corner formation may have a radius of between 90% and 110% of the radius of each roller milling element.

In the apparatus, the upper disc-like element may have a flat under surface.

5

The apparatus may include biasing means for biasing one of the disc-like elements towards the other, thereby to operatively subject material within the milling zone to compression.

10 In the apparatus, the inlet may be spaced from an outer periphery of the milling zone. The apparatus may include an inlet opening through the upper disc-like element.

The apparatus may include a collection bin underneath and radially underlapping the peripheral outlet, to collect the discharge from the milling zone.

15

The invention is now described by way of example embodiments of a diminution apparatus, in accordance with the second aspect of the invention, for performing a method of diminishing particulate material, in accordance with the first aspect of the invention, with reference to the accompanying diagrammatic drawings. In the drawings:

20 Figure 1 shows, schematically, partially in axial section, a first embodiment of a diminution apparatus in accordance with the invention; and

Figure 2 shows, schematically, partially in axial section, a second embodiment of a diminution apparatus in accordance with the invention.

25 In Figure 1, a first embodiment of a diminution apparatus in accordance with the invention is generally indicated by reference numeral 10. The apparatus 10 will operate mostly as a mill. Thus, for convenience, it will herein generally be referred to as the mill 10.

30 The mill 10 comprises a housing which is generally hollow cylindrical and is indicated by reference numeral 12. The housing 12 has a vertical axis of radial symmetry 13. The housing 12 has a top wall 12.1, and an internal mounting platform 14 which is of disc shape and is mounted co-axially within the housing 12, at about mid-height of the housing 12.

The mill 10 comprises a pair of disc-like elements 16 positioned co-axially within the housing 12.

- 5 The pair of disc-like elements 16 include a first disc-like element in the form of a stator 18 which is co-axially mounted on the mounting platform 14. The stator 18 is in the form of a liner or an assembly of liners which is of a wear resistant material, which can readily be replaced. The stator 18 has a flat under surface 18.1.
- 10 The pair of disc-like elements 16 further includes a second disc-like element in the form of a rotor 20. The rotor 20 is co-axial with the stator 18 and comprises a base 22 secured on a main shaft as will be described hereinafter. The base 22 underlines and supports a liner 24 of abrasion resistant material and which can easily be replaced.
- 15 The liner 24 has an upper surface 24.1 which is flat. The rotor 20 further comprises a peripheral wall 26 secured to the liner 24. The peripheral wall 26 forms a peripheral inner corner formation 26.1 which is rounded at a predetermined curvature which will be referred to hereinafter.
- 20 In other embodiments, the disc-like elements may be operatively counter-rotated.

Suspension and driving of the rotor 20 are described below.

- 25 A right angled gearbox 28 is mounted on the top wall 12.1. The gearbox 28 has a large speed reduction ratio and may, for example, be a bevel-gear-type gearbox. An electric motor 30, also mounted on the top wall 12.1, is drivingly connected to the gearbox 28 via a coupling 32.

- 30 In another embodiment, instead of or in addition to the coupling 32, a V-belt and pulley arrangement may be used to allow adjustment of the speed. A step-up/step-down pulley arrangement may be used.

An output shaft 34 of the gearbox 28 extends co-axially through the top wall 12.1 into the interior of the housing 12 where it is mounted by means of coupling members 36

including an internally splined socket 38, to an externally splined shaft 40 extending axially in the housing 12.

5 A collar assembly 42 in the form of a pair of lock nuts is secured to the shaft 40. The collar assembly 42 (and with it the whole of the shaft assembly, and the rotor 20) is resiliently supported via a coil spring 44 operating under compression, a cup 46 seating a lower end of the coil spring 44, and a bearing assembly 48 mounting the cup 46 on the mounting platform 14. It is to be borne in mind that the mounting platform 14 is stationary and the bearing assembly 48 thus allows the cup 46, the compression spring
10 44 and the collar assembly 42 to rotate with the shaft 40.

The shaft 40 extends in the form of a shaft extension 50 through a passage provided for that purpose centrally through the mounting platform 14 and the stator 18 to suspend and to drive the rotor 20. It is to be appreciated that the compression spring 44, as
15 allowed by the splined coupling 38, biases the rotor 20 upwardly, i.e. the upper surface 24.1 of the rotor 20 is biased toward the under surface 18.1 of the stator 18.

A round cylindrical sleeve 51 is disposed around a bottom part of the shaft extension 50 with clearance between them to provide a rattle-fit. The sleeve 51 is fitted snugly and
20 securely through the said passage provided through the platform 14 and the stator 18. A top end of the sleeve 51 is at approximately mid-height of the spring 44 and a bottom end thereof depends from the under surface 18.1 of the stator 18. The sleeve 51 may be provided with at least one grease nipple for introducing grease in between the sleeve 51 and the shaft extension 50.

25 A milling zone 52 is defined intermediate the under surface 18.1 and the upper surface 24.1. It is to be appreciated that the milling zone 52 is rendered recessed by the peripheral wall 26 described above. A plurality of roller milling elements in the form of round milling balls 54 is provided within the milling zone 52. A central spacer 56 spaces
30 the milling balls 54 from the shaft 50.

A charging chute 62 extends through the wall of the housing 12 and by means of an internal passage 64 through the mounting platform 14 and the stator 18 to have an outlet into the milling zone 52, toward, but not at, a centre of the milling zone 52.

A collection bin 58 has a round cylindrical wall 58.1 surrounding the stator 18, rotor 20 and milling zone 52 with substantial clearance. A frusto-conical section 58.2 extends from a bottom of the round cylindrical portion 58.1 to a discharge 60 leading out of the housing 12.

In use, the rotor 20 is rotated relative to the stator 18. Due to the bias by means of the compression spring 44, the balls 54 are pressed upwardly against the under surface 18.1 of the stator 18 and are rolled about the axis 13. In this regard, it is to be appreciated that the peripheral corner 26.1 is curved commensurately with the curvature of the balls 54 which can roll snugly along the peripheral inner corner formation 26.1. Furthermore, it is to be appreciated that, because of the rolling action, centrifugal effect biases the balls 54 radially outwardly.

Particulate material, especially ore, to be milled is introduced via the charging chute 62 and the internal passage 64 into the milling zone 52. The spacer 56 protects the shaft 50 from the ore being introduced. The ore is milled within the milling zone 52, mainly between the liner 24 of the rotor 20 and the milling balls 54. It is to be appreciated that the milling action is a roller action rather than a sliding action. Thus, it is expected that abrasion will not take place to a large extent. In this regard, it is to be appreciated that the ore being milled will be rotated and, on account of rotation and centrifugal effect, will tend to move radially outwardly. A final milling action takes place between the balls 54 at the periphery and the peripheral corner 26.1. Ore being milled accumulates toward the periphery of the milling zone 52 and ultimately spills over the peripheral wall 26 to be collected in the collection bin 58 and discharged through the discharge 60.

A scraper plate or fin 63, depending from the stator 18 and having a bottom edge just above the spacer 56, scrapes any material that has landed on the spacer 56 from the spacer and towards the balls 54.

The Applicant regards this invention as providing an efficient and elegant method of and means for milling, especially, ore.

It is to be appreciated that the mill in accordance with the invention can be provided in a wide range of sizes as it is versatile in respect of size. Furthermore, speed of rotation of the rotor 20 can easily be adjusted by appropriate selection of the gearbox 28 and the speed of the electric motor 30, or, in some embodiments having a pulley and V-belt
5 coupling, by selection of the pulley combination. Yet furthermore, the pressure in the milling zone 52 can be varied by selection of the spring 44.

In Figure 2, a second embodiment of an apparatus in accordance with the invention is generally indicated by reference numeral 65. The apparatus 65 will operate mostly as a
10 mill. Thus, for convenience, it will herein generally be referred to as the mill 65.

The mill 65 includes many features that are identical or similar to features of the mill 10 of Figure 1, as described above. Such features are again designated by the same reference numerals as before and a description of these features is not repeated here.
15

The mill 65 includes an irrotational biasing and support arrangement 64 mounted on a bottom wall 12.2 of the housing 12. The arrangement 64 includes:

a round plinth 66, co-axial with the axis 13;

20 biasing means in the form of an arrangement of compression coil springs 68 mounted on the plinth 66;

a round floating slab 70 mounted on the coil springs and co-axial with the housing 12; and

25 an arrangement of four bearing rollers 72 (of which only three are shown) mounted on the slab 70, the rollers having respective rotational axes disposed radially with respect to the axis 13 and at 90° angular spacing about the axis 13.

The base 22 defines an annular bearing under surface 74 for bearing against the rollers 72. The springs 68 are in compression and thus urge the rollers 72 to bear against the under surface 74. In use of the mill 65, the base 22 rotates, causing the under surface
30 74 to be displaced over the rollers 72. The springs 68 thus cooperate with the compression spring 44 in biasing the base 22 upwards and pressing the balls 54 upwardly against the under surface 18.1 of the stator 18.

In another embodiment including an irrotational biasing and support arrangement such as the arrangement 64, the compression spring 44 may be omitted.

5 The mill 65 includes also a bearing 76 mounted centrally on the slab 70 within which a bottom end of the shaft extension 50 is received and held centered. The bearing 76 transfers an axial load from the slab 70 to the shaft extension 50 and maintains the bottom end of the shaft extension centered on the slab. It may, for example, be a tapered roller bearing.

10 The mill 65 includes a modified hopper 78, defining therein an annular collector channel 80 for collecting, in use, diminished ore that had spilled over the peripheral wall 26. The hopper 78 has a discharge pipe 82 for such ore and may be provided with a vibration mechanism for facilitating displacement of material from the channel 80 towards the discharge pipe 82.

CLAIMS:

1. A method of diminuting particulate material, the method including:
effecting relative rotation of a pair of superimposed disc-like elements which
5 are axially spaced to provide a milling zone therebetween and having roller milling
elements in the milling zone;
introducing the particulate material into the milling zone;
exposing the particulate material to milling action in the milling zone; and
discharging diminuted material via a peripheral outlet out of the milling zone.
10
2. A method as claimed in claim 1, including introducing the particulate material into
the milling zone at a position spaced from an outer periphery of the milling zone.
3. A method as claimed in any of the preceding claims, in which the relative rotation
15 of the disc-like elements is effected about a common, vertical rotation axis.
4. A method as claimed in any of the preceding claims, in which the relative rotation
of the disc-like elements is effected by holding one of the disc-like elements, which
will then be a stator, stationary and rotating the other disc-like element, which will
20 then be a rotor.
5. A method as claimed in any of claims 1 to 3, in which the relative rotation of the
disc-like elements is effected by counter-rotating them.
- 25 6. A method as claimed in any of the preceding claims, including urging one of the
disc-like elements toward the other, thereby applying compression to material in
the milling zone.
7. A method as claimed in any of the preceding claims, including using centrifugal
30 effect on account of rotation on the milling elements and the particulate material
being milled to bias the milling elements outwardly and to move the particulate
material outwardly.

8. A method as claimed in claim 7, including limiting outward movement of the milling elements beyond a predetermined boundary by means of a peripheral wall, and allowing diminished material to spill over the wall to enable the diminished material to be collected.
- 5
9. A diminution apparatus suitable for use in diminishing particulate material, the apparatus including:
- an upper disc-like element and a lower disc-like element that are superimposed and spaced apart to provide a milling zone therebetween;
 - 10 drive means for effecting relative rotation of the disc-like elements;
 - roller milling elements in the milling zone;
 - an inlet for introducing particulate material into the milling zone; and
 - an outlet for discharging diminished material from the milling zone.
- 15
10. An apparatus as claimed in claim 9, in which the disc-like elements are mounted co-axially about a common, vertical rotation axis.
11. An apparatus as claimed in any of claims 9 to 10, including drive means for rotating one of the disc-like elements, which will then be a rotor, the other disc-like
- 20 element, which will then be a stator, being held irrotationally.
12. An apparatus as claimed in any of claims 9 to 10, including drive means for counter-rotating the disc-like elements.
- 25
13. An apparatus as claimed in any of claims 9 to 12, in which the lower disc-like element has a recessed upper surface for holding the milling elements and particulate material.
- 30
14. An apparatus as claimed in claim 13, in which the lower disc-like element has a generally flat upper surface and a peripheral wall rendering it recessed, the wall retaining the milling elements within the milling zone and allowing diminished material to be discharged over it.

15. An apparatus as claimed in claim 14, in which a peripheral inner corner formation between the flat upper surface and a radially inner surface of the wall is rounded.
- 5 16. An apparatus as claimed in claim 15, in which the roller milling elements are spherical and of the same size and the corner formation has a radius of between 90% and 110% of the radius of each roller milling element.
- 10 17. An apparatus as claimed in any of claims 9 to 16, in which the upper disc-like element has a flat under surface.
18. An apparatus as claimed in any of claims 9 to 17, which includes biasing means for biasing one of the disc-like elements towards the other, thereby to operatively subject material within the milling zone to compression.
- 15 19. An apparatus as claimed in any of claims 9 to 18, in which the inlet is spaced from an outer periphery of the milling zone.
- 20 20. An apparatus as claimed in claim 19, which includes an inlet opening through the upper disc-like element.
21. An apparatus as claimed in any of claims 9 to 20, which includes a collection bin underneath and radially underlapping the peripheral outlet, to collect the discharge from the milling zone.

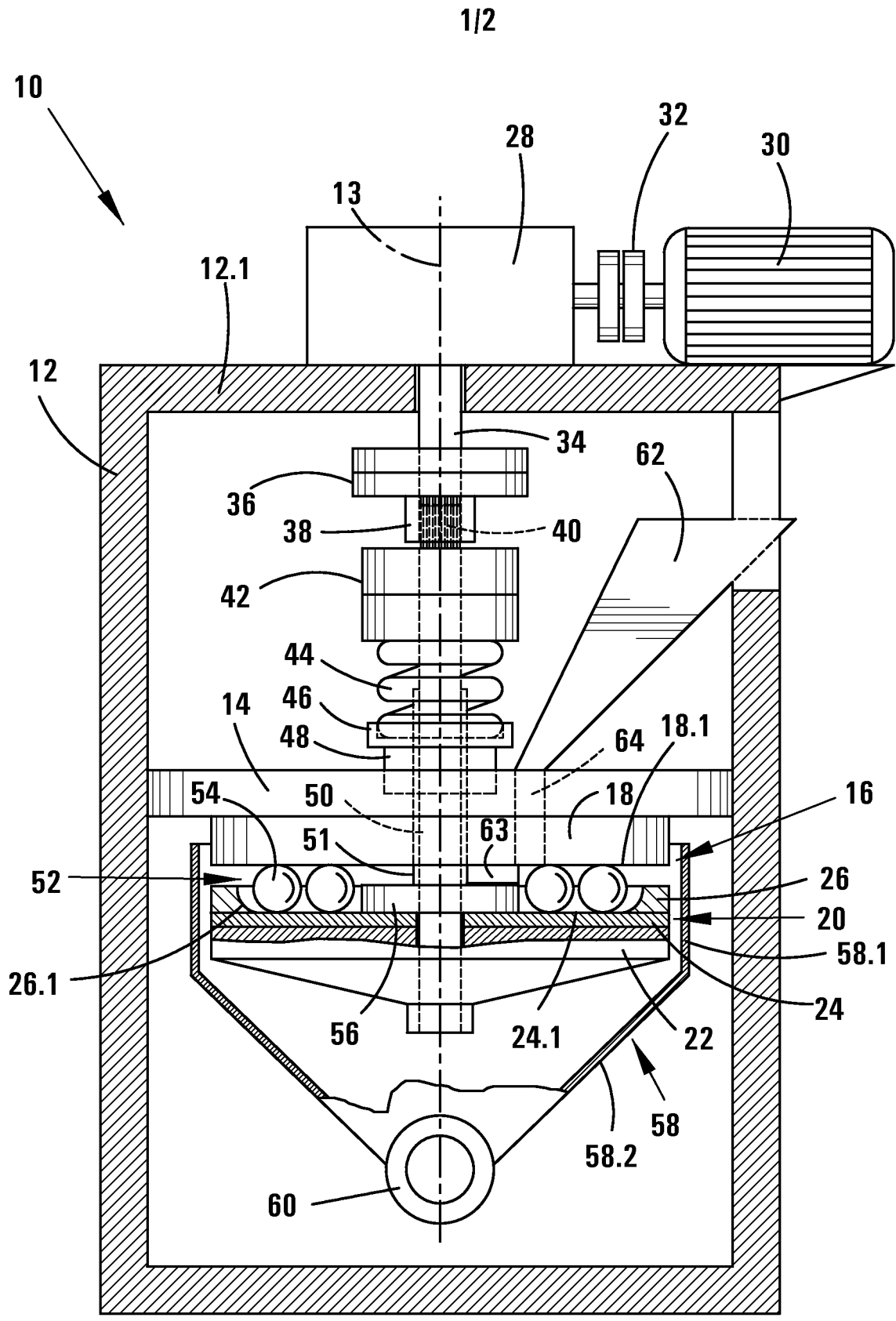

FIG. 1

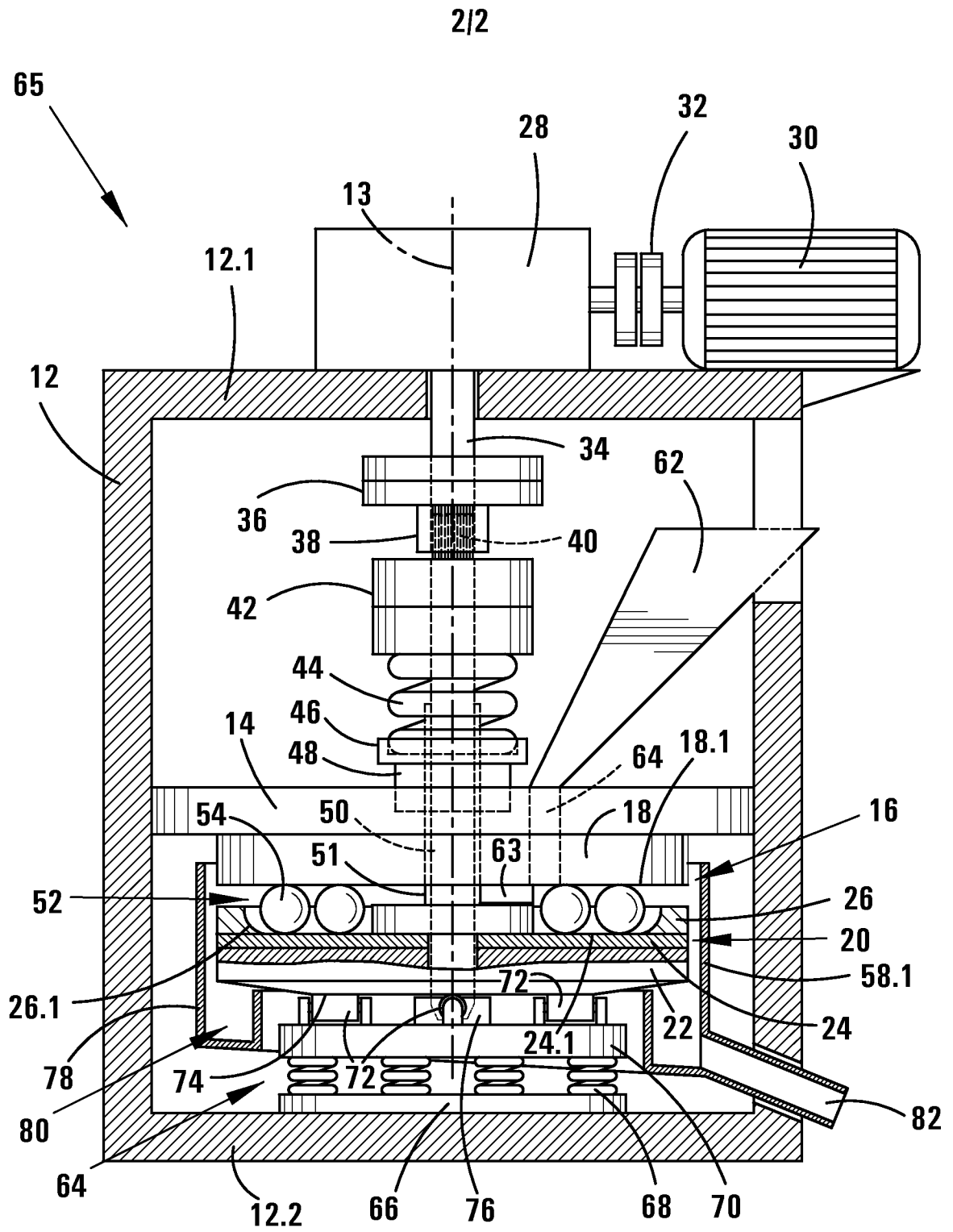

FIG. 2