



US00D996367S

(12) **United States Design Patent**  
**Muthu et al.**

(10) **Patent No.:** **US D996,367 S**

(45) **Date of Patent:** **\*\* Aug. 22, 2023**

(54) **HOUSING FOR AN ION GENERATOR**

FOREIGN PATENT DOCUMENTS

(71) Applicant: **Dometic Sweden AB**, Solna (SE)

WO 2007078135 A1 7/2007

(72) Inventors: **Anoop Muthu**, Kerala (IN);  
**Anna-Carin M. Neale**, Farsta (SE)

OTHER PUBLICATIONS

(73) Assignee: **Dometic Sweden AB**, Solna (SE)

Registration Certificate issued in United Kingdom Application No. 6191421 mailed on Feb. 11, 2022.

(\*\*) Term: **15 Years**

(Continued)

(21) Appl. No.: **29/816,164**

*Primary Examiner* — Derrick E Holland

(22) Filed: **Nov. 19, 2021**

(74) *Attorney, Agent, or Firm* — Dinsmore & Shohl LLP

(57) **CLAIM**

The ornamental design for a housing for an ion generator, as shown and described.

**Related U.S. Application Data**

**DESCRIPTION**

(63) Continuation-in-part of application No. 29/803,390, filed on Aug. 12, 2021.

(51) **LOC (14) Cl.** ..... **13-01**

(52) **U.S. Cl.** ..... **D13/122**

USPC ..... **D13/122**

(58) **Field of Classification Search**

USPC ..... D13/112, 113, 114, 116, 118, 122, 184,  
D13/199; D21/834, 837; D23/207, 355,  
D23/356, 366

CPC ..... F16M 3/00; F02B 2063/045; F02B  
2063/046; F02B 63/04; F02B 63/042;  
F02B 63/048; E04H 15/36; E04H 15/58;  
E04H 15/425; H05K 5/02; H05K 5/03;  
H05K 5/10; H05K 5/0213; H05K 5/0226;  
H02K 3/24; H02K 3/47; F01N 1/083;  
F01N 1/084; H01T 23/00; A61L 9/22

See application file for complete search history.

FIG. 1 is a top perspective view of a first embodiment of a housing for an ion generator showing the new design; FIG. 2 is a bottom perspective view of the design of FIG. 1; FIG. 3 is a front view of the design of FIG. 1; FIG. 4 is a rear view of the design of FIG. 1; FIG. 5 is a first side view of the design of FIG. 1; FIG. 6 is a second side view of the design of FIG. 1; FIG. 7 is a top view of the design of FIG. 1; FIG. 8 is a bottom view of the design of FIG. 1; FIG. 9 is a top perspective view of a second embodiment of a housing for an ion generator showing the new design; FIG. 10 is a bottom perspective view of the design of FIG. 9; FIG. 11 is a front view of the design of FIG. 9; FIG. 12 is a rear view of the design of FIG. 9; FIG. 13 is a first side view of the design of FIG. 9; FIG. 14 is a second side view of the design of FIG. 9; FIG. 15 is a top view of the design of FIG. 9; and, FIG. 16 is a bottom view of the design of FIG. 9.

The broken lines shown represent the portions of the housing for an ion generator that form no part of the claimed design.

(56) **References Cited**

**U.S. PATENT DOCUMENTS**

D205,975 S \* 10/1966 Sato ..... D15/1  
D309,288 S \* 7/1990 Haverly ..... D13/114  
6,471,752 B1 10/2002 Lewis

(Continued)

**1 Claim, 16 Drawing Sheets**

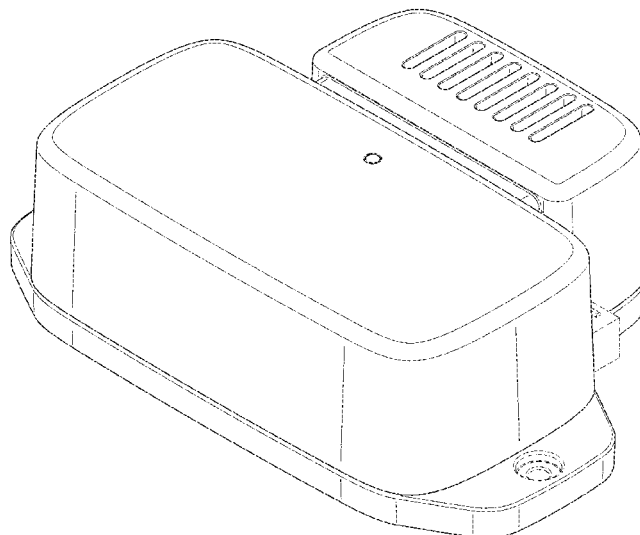

(56)

References Cited

U.S. PATENT DOCUMENTS

D490,374 S \* 5/2004 Amakawa ..... D13/112  
 D513,070 S 12/2005 Haranaka  
 6,987,792 B2 1/2006 Do et al.  
 D574,323 S \* 8/2008 Waaler ..... D13/112  
 8,149,561 B2 4/2012 Shimanaka  
 D662,055 S \* 6/2012 Little ..... D13/122  
 8,564,924 B1 10/2013 Waddell  
 D696,196 S \* 12/2013 Plato ..... D13/112  
 8,861,167 B2 10/2014 Waddell  
 8,861,168 B2 10/2014 Waddell  
 8,873,215 B2 10/2014 Waddell  
 9,025,303 B2 5/2015 Waddell  
 9,168,538 B2 10/2015 Waddell  
 9,289,779 B2 3/2016 Waddell  
 D753,614 S 4/2016 Xiang et al.  
 9,441,845 B2 9/2016 Waddell  
 9,478,948 B2 10/2016 Waddell  
 9,509,125 B2 11/2016 Waddell  
 9,551,497 B2 1/2017 Waddell  
 9,660,425 B1 5/2017 Sunshine  
 9,839,714 B2 12/2017 Waddell  
 9,847,623 B2 12/2017 Sunshine  
 9,849,208 B2 12/2017 Waddell  
 9,925,292 B2 3/2018 Waddell  
 9,925,567 B2 3/2018 Waddell  
 9,985,421 B2 5/2018 Sunshine  
 10,014,667 B2 7/2018 Sunshine  
 10,020,180 B2 7/2018 Waddell  
 10,073,055 B2 9/2018 Waddell  
 10,111,978 B2 10/2018 Waddell  
 10,128,075 B2 11/2018 Waddell  
 10,153,623 B2 12/2018 Sunshine  
 D840,932 S \* 2/2019 Markoski ..... D13/112  
 10,297,984 B2 5/2019 Sunshine  
 10,317,096 B2 6/2019 Waddell  
 10,319,569 B2 6/2019 Waddell  
 10,322,205 B2 6/2019 Waddell  
 10,383,970 B2 8/2019 Waddell  
 10,439,370 B2 10/2019 Sunshine  
 D875,046 S 2/2020 Waddell  
 10,566,769 B2 2/2020 Waddell  
 D887,982 S \* 6/2020 Schmidt ..... D13/122  
 10,695,455 B2 6/2020 Waddell  
 10,710,123 B2 7/2020 Waddell  
 D899,560 S \* 10/2020 Kawasaki ..... D23/207  
 10,978,858 B2 4/2021 Sunshine  
 10,980,911 B2 4/2021 Waddell  
 11,018,478 B2 5/2021 Sunshine  
 2011/0165018 A1 \* 7/2011 Lynn ..... A61L 9/20  
 422/4  
 2013/0232807 A1 9/2013 Robert et al.  
 2015/0165084 A1 6/2015 Waddell

2016/0218490 A1 7/2016 Nishida et al.  
 2016/0221002 A1 8/2016 Lin et al.  
 2019/0247862 A1 8/2019 Galbreath et al.  
 2019/0247893 A1 8/2019 Waddell  
 2019/0328923 A1 10/2019 Cunningham  
 2020/0062622 A1 2/2020 Linley et al.  
 2020/0340679 A1 10/2020 Waddell  
 2020/0388994 A1 12/2020 Waddell  
 2021/0196853 A1 7/2021 Waddell  
 2021/0197208 A1 7/2021 Sunshine

OTHER PUBLICATIONS

Registration Certificate issued in United Kingdom Application No. 6191422 mailed on Feb. 11, 2022.  
 Registration Certificate issued in United Kingdom Application No. 6191423 mailed on Feb. 11, 2022.  
 Notification of Registration issued in European Union Application No. 008858435-0001-0003 mailed on Feb. 18, 2022.  
 U.S. Appl. No. 17/884,135 titled “Ion Generator for HVAC System Application” filed Aug. 9, 2022.  
 PCT Application No. PCT/IB2022/057429 titled “Ion Generator for HVAC System Application” filed on Aug. 9, 2022.  
 International Search Report and Written opinion issued in PCT Application No. PCT/IB2022/057429 dated Nov. 18, 2022.  
 Plasma Air; Plasma Air’s Needlepoint Bipolar Ionization Technology Passes, 1 page, Aug. 5, 2020.  
 GPS; Third-Party Testing, Needlepoint Bipolar Ionization Test Results, 10 pages, Jul. 21, 2021.  
 AtmosAir; About—Certifications—AtmosAir; 2 pages, Jul. 20, 2021.  
 Nu-Calgon; iWave-R Air Purifier, 6 pages, Jul. 22, 2021.  
 Shanghai Zeluo Electronic Technology Co., Ltd., Trumpxp; Product Center—Air Purifier, Retrieved from Internet Wayback Machine on Mar. 30, 2022, but first published Feb. 23, 2013.  
 U.S. Appl. No. 63/232,368 entitled “Ion Generator and System with Mobile HVAC” filed Aug. 12, 2021.  
 Design U.S. Appl. No. 29/803,390 entitled “Housing for an Ion Generator” filed Aug. 12, 2021.  
 European Union Application No. 008858435-0001-0003 titled “Housing for an Ion Generator” filed on Feb. 11, 2022.  
 United Kingdom Application No. 6191421 titled “Housing for an Ion Generator” filed on Feb. 11, 2022.  
 United Kingdom Application No. 6191422 titled “Housing for an Ion Generator” filed on Feb. 11, 2022.  
 United Kingdom Application No. 6191423 titled “Housing for an Ion Generator” filed on Feb. 11, 2022.  
 Notice of Allowance issued in U.S. Appl. No. 29/803,390 dated Jan. 25, 2023.  
 Notice of Allowability issued in U.S. Appl. No. 29/803,390 dated May 5, 2023.

\* cited by examiner

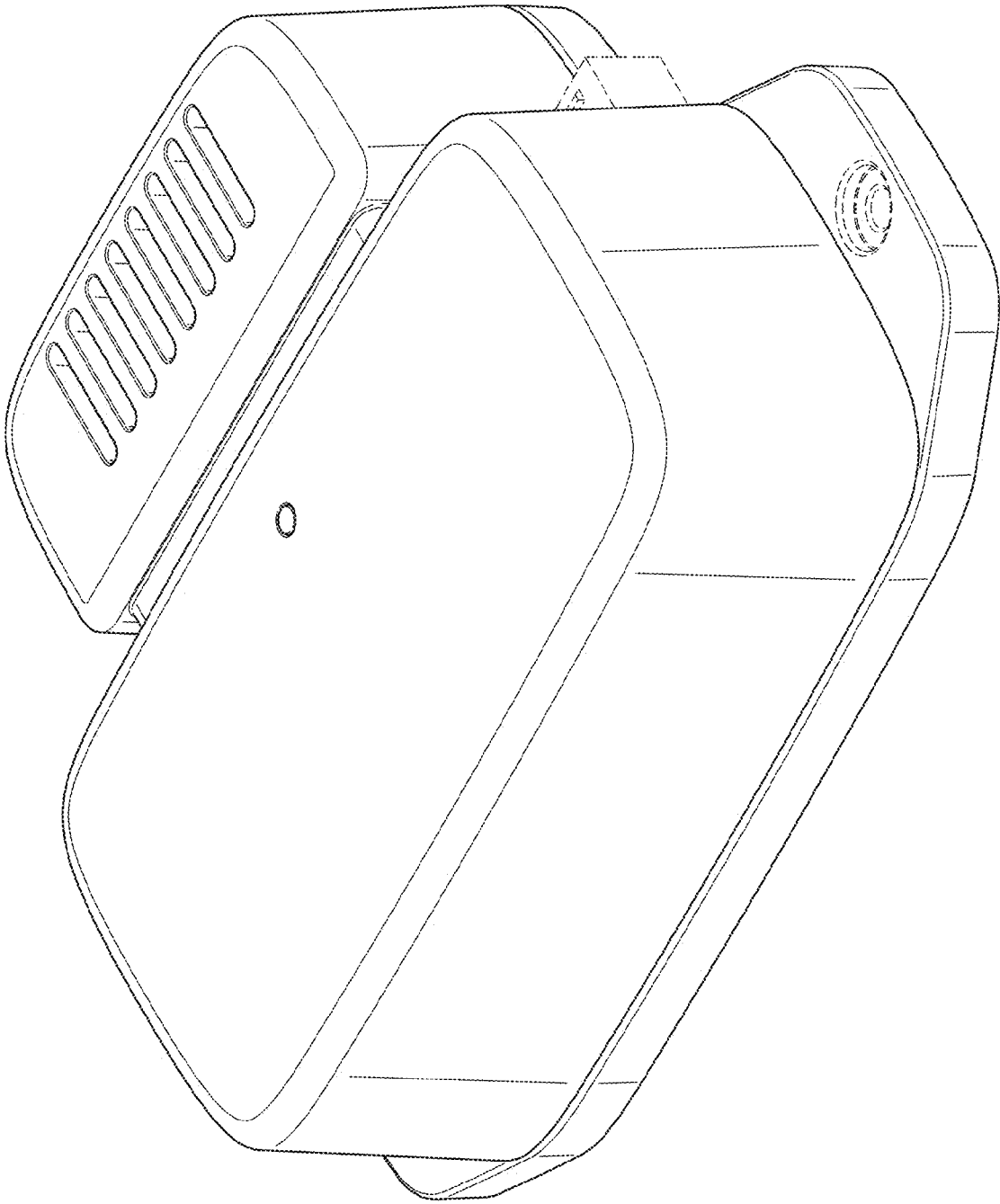

FIG. 1

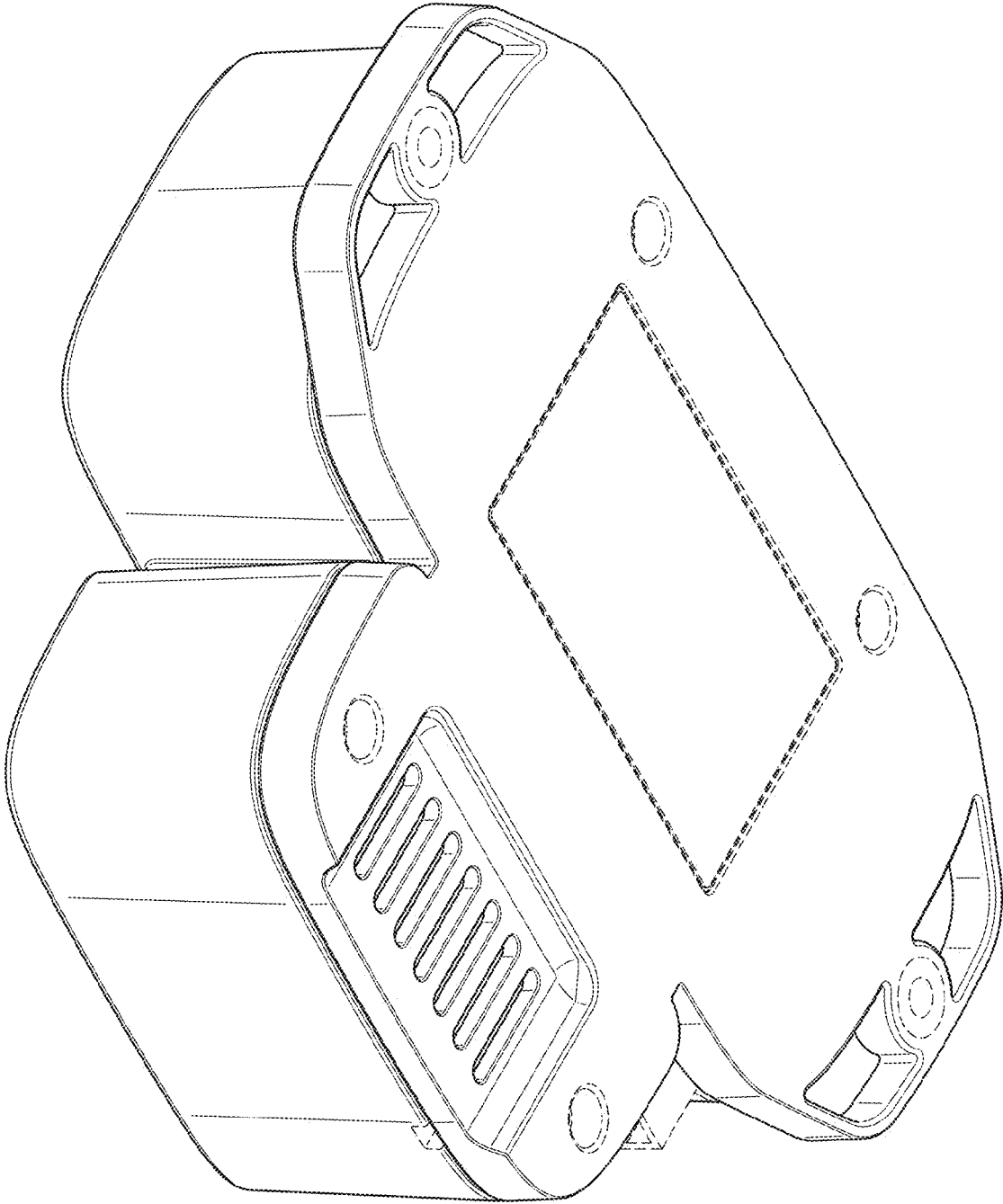

FIG. 2

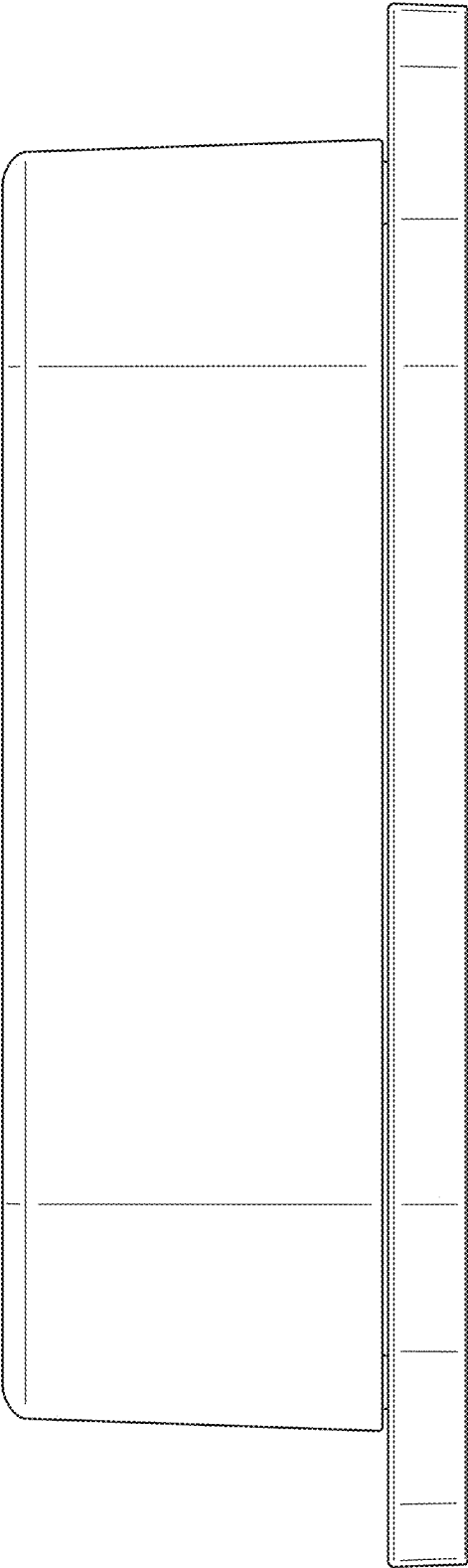

FIG. 3

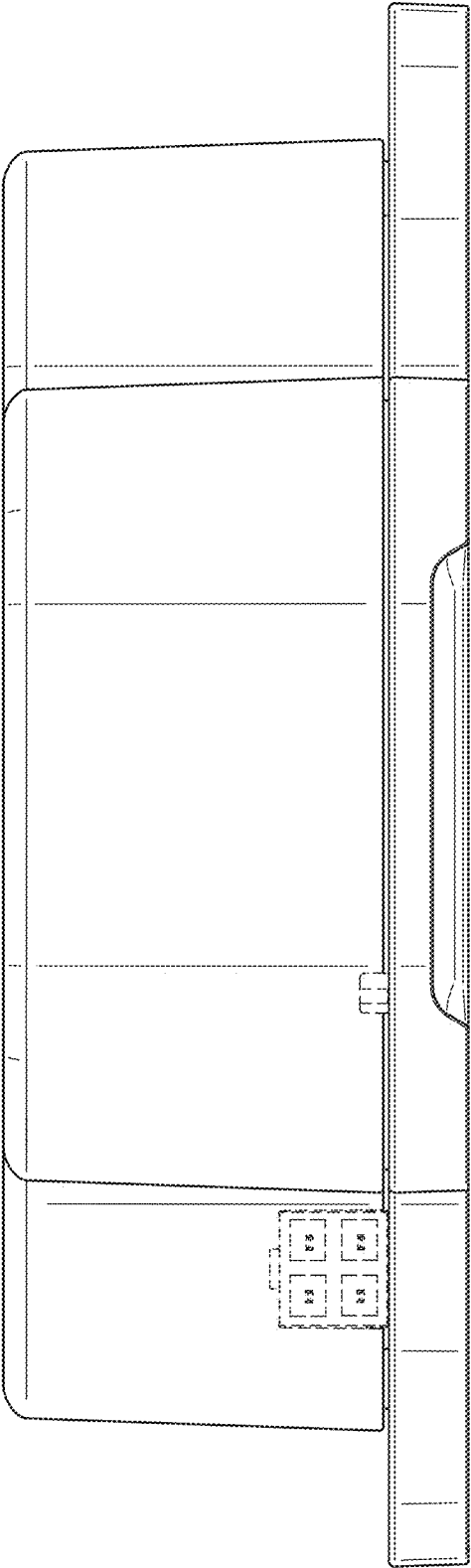

FIG. 4

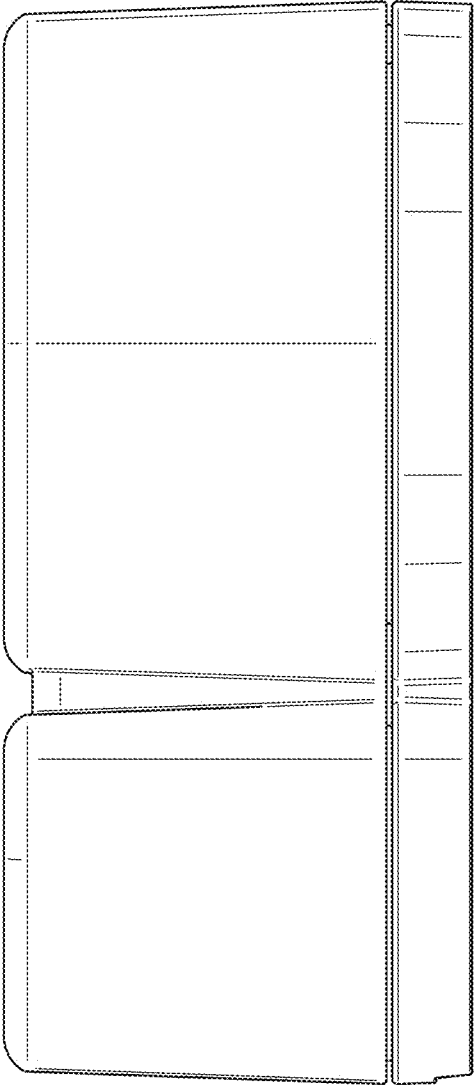

FIG. 5

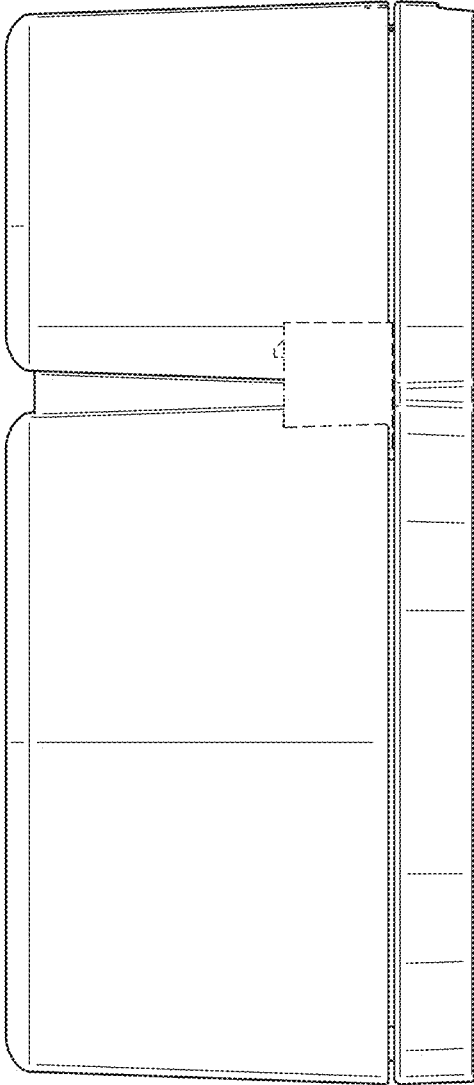

FIG. 6

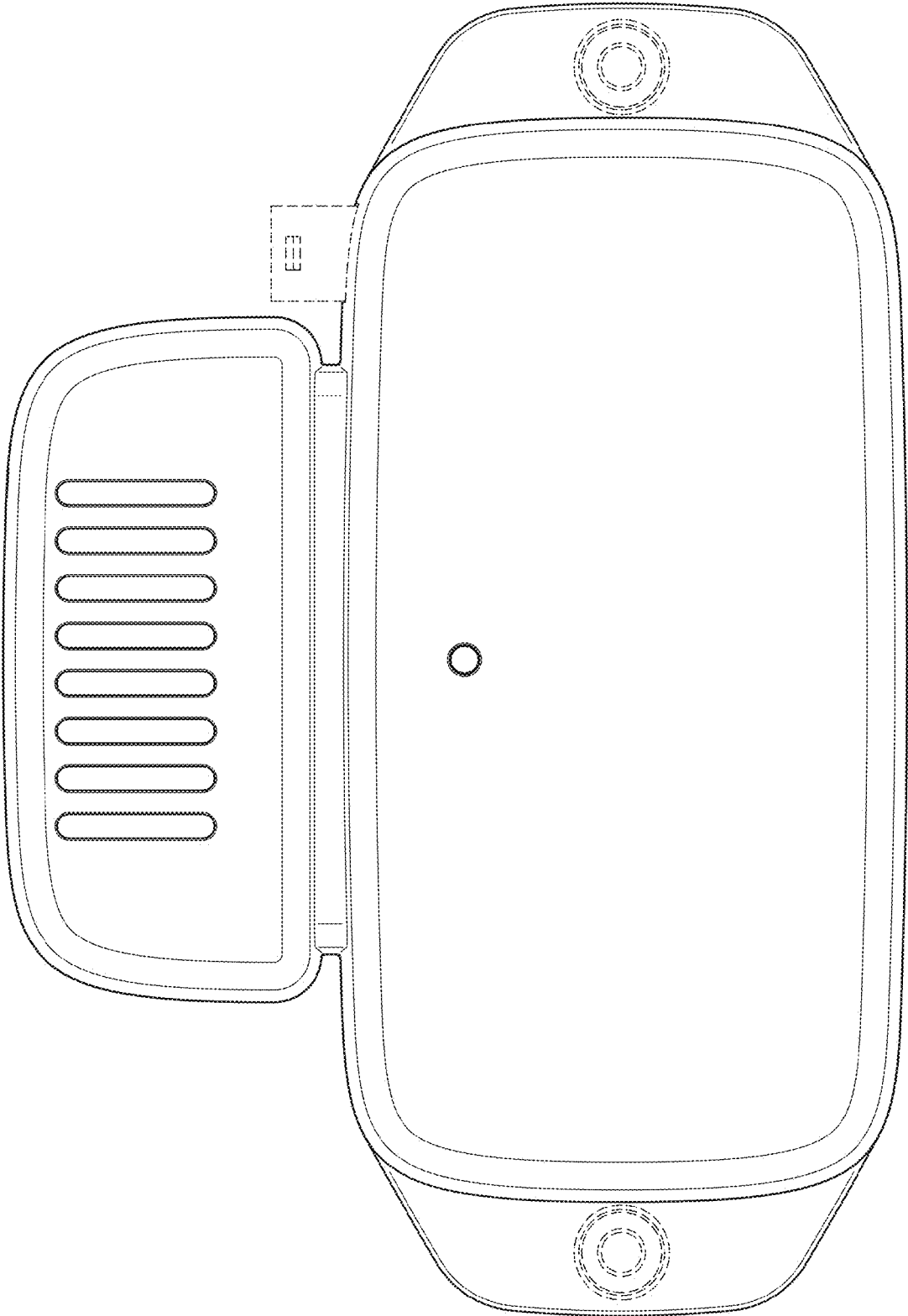

FIG. 7

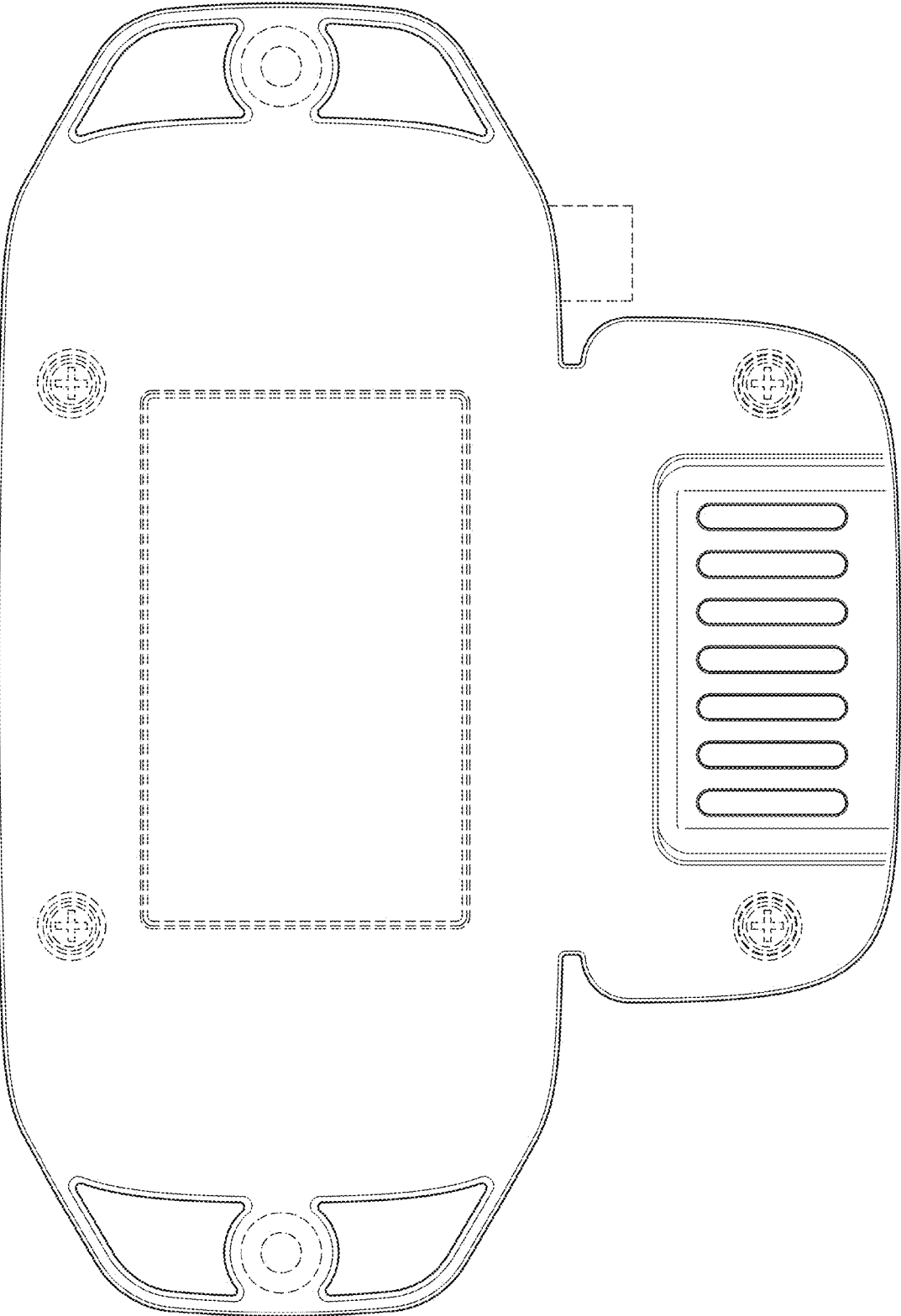

FIG. 8

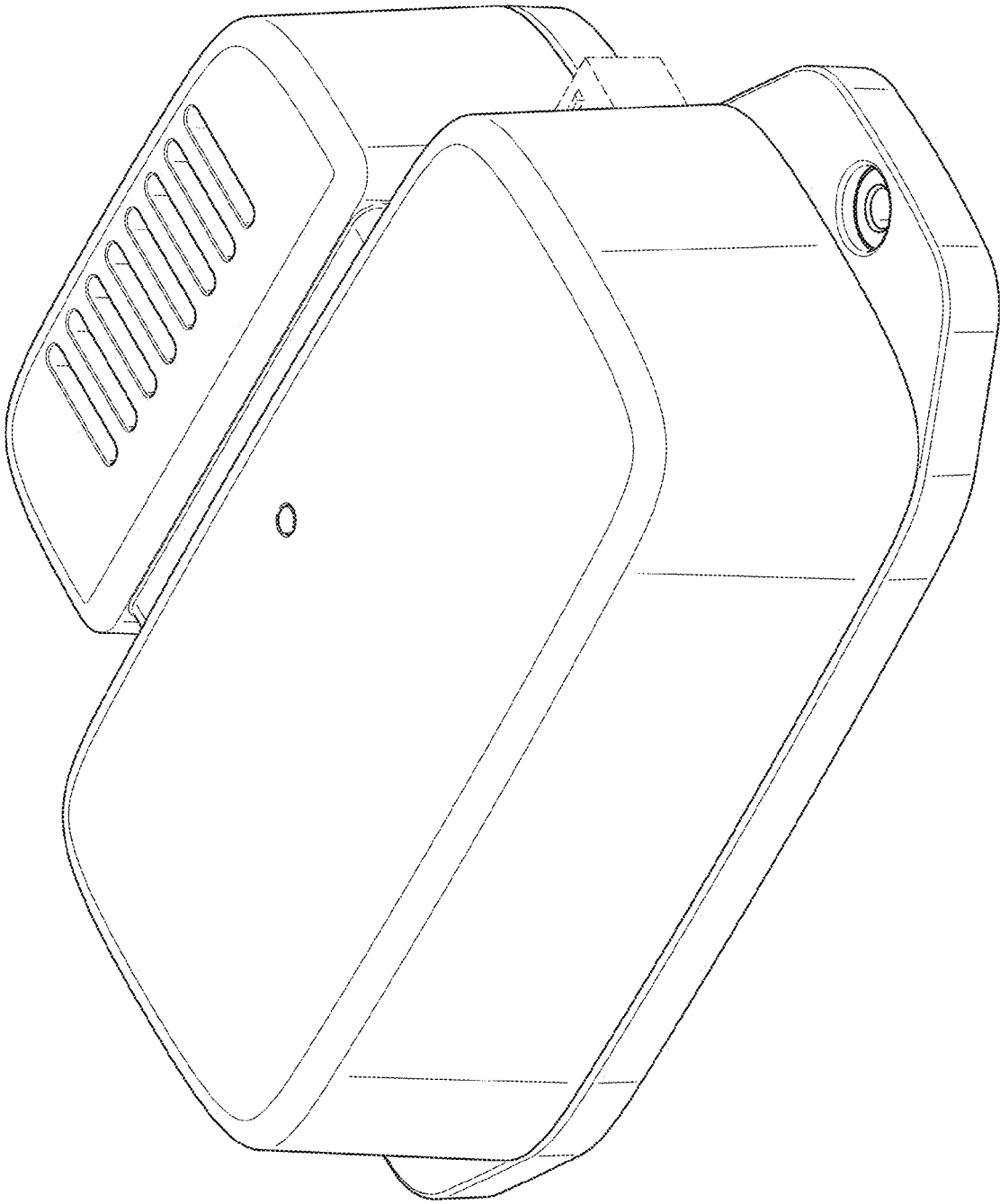

FIG. 9

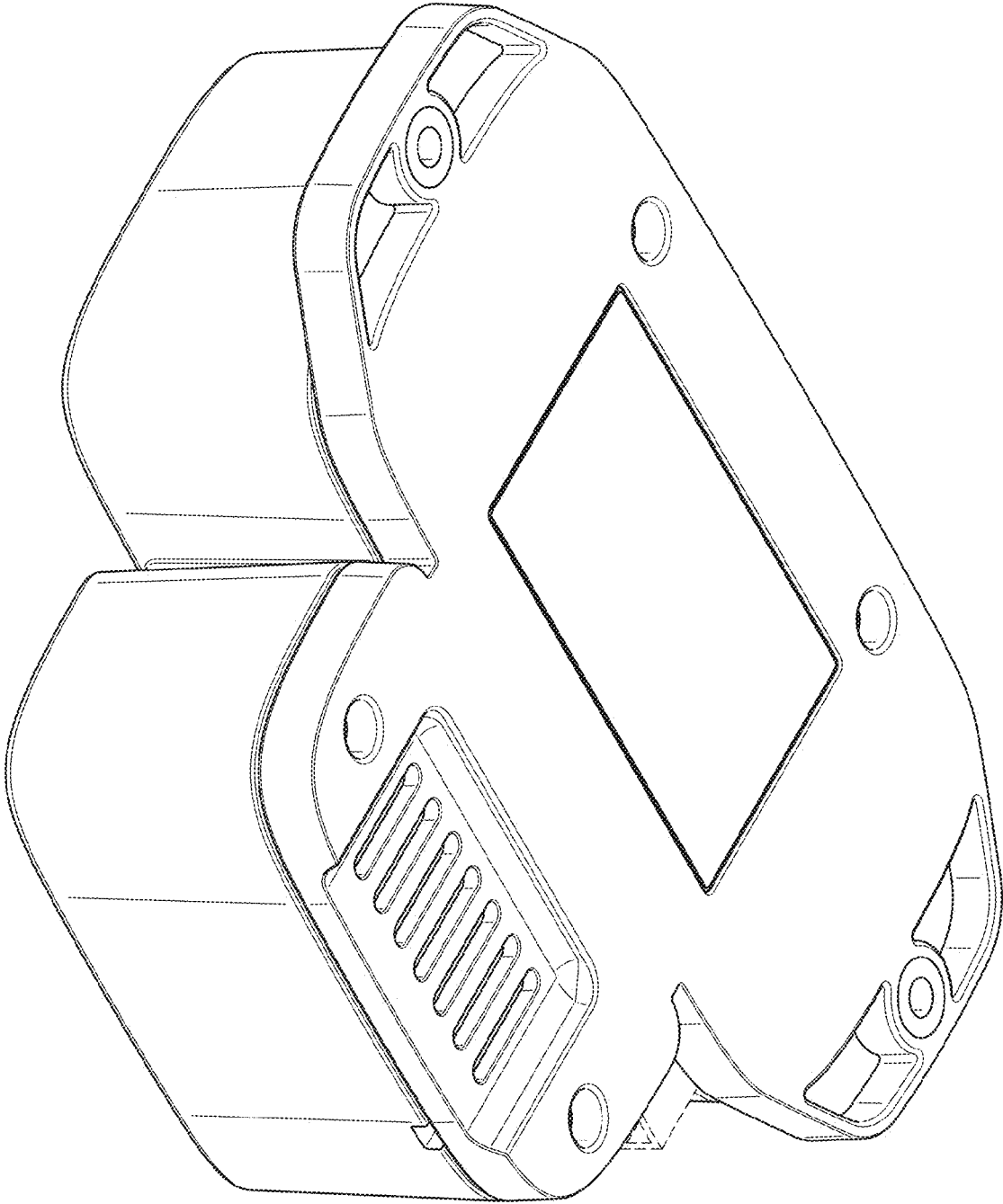

FIG. 10

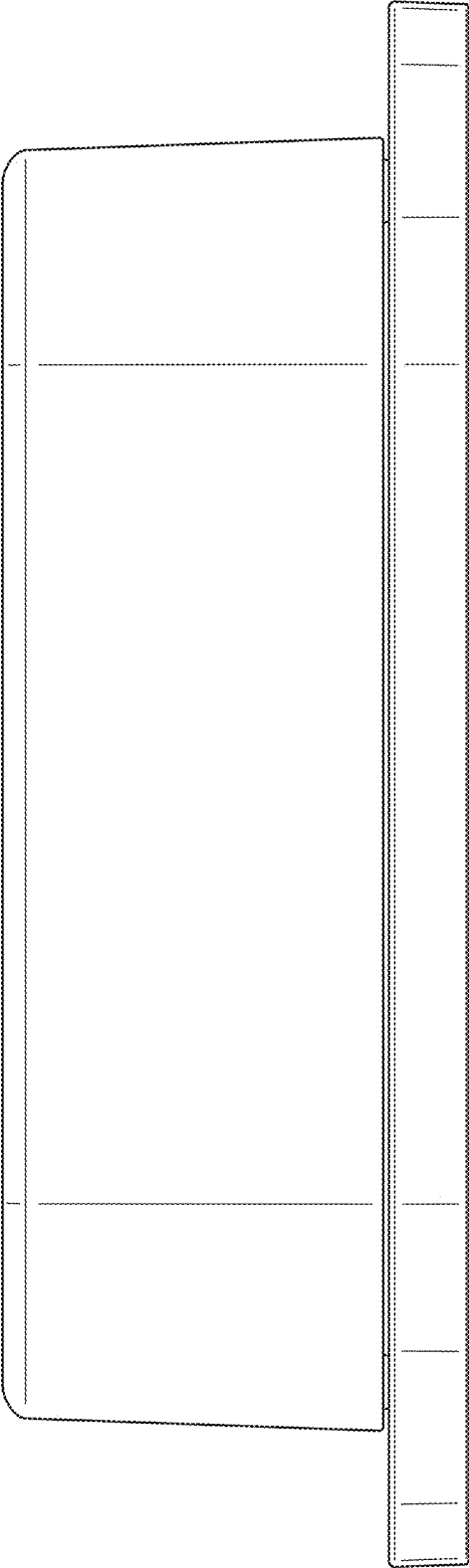

FIG. 11

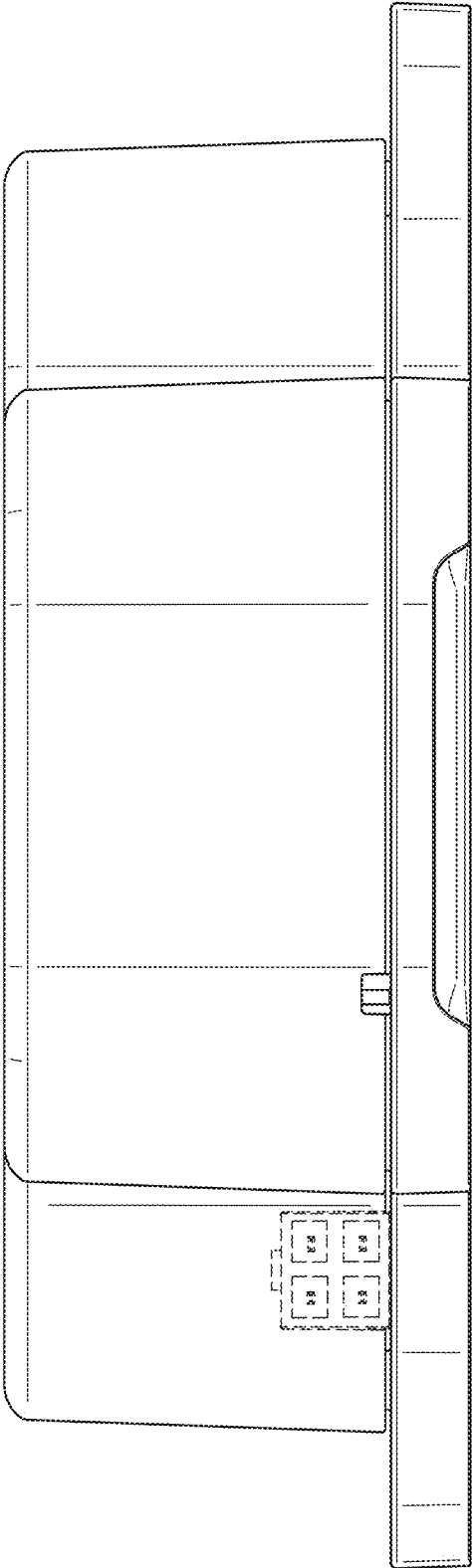

FIG. 12

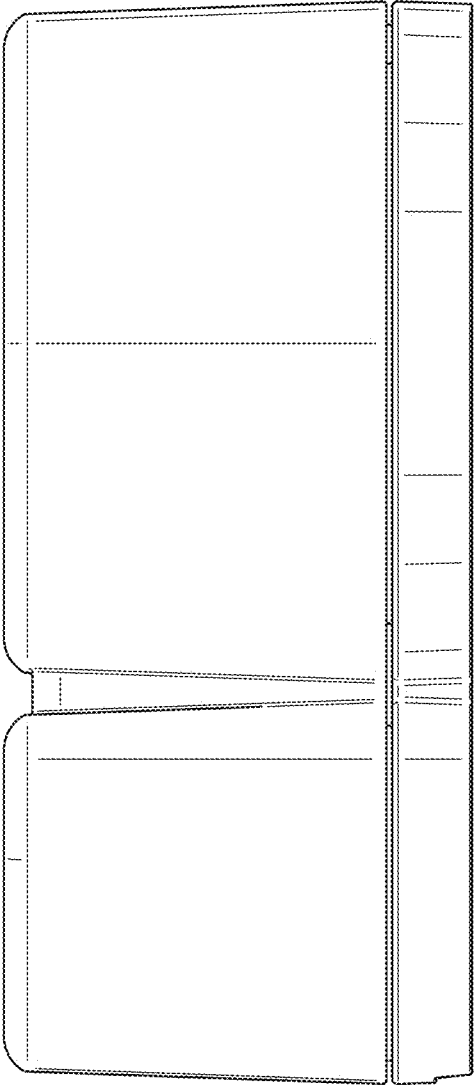

FIG. 13

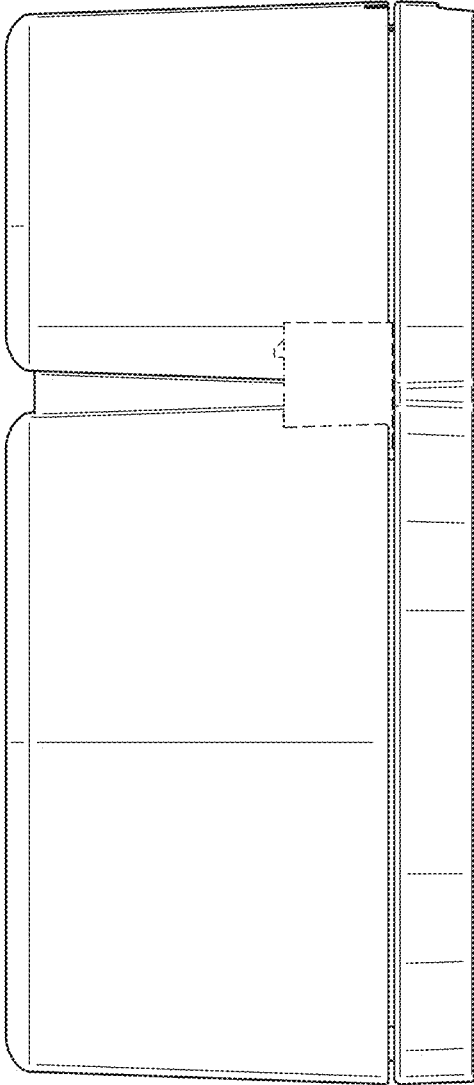

FIG. 14

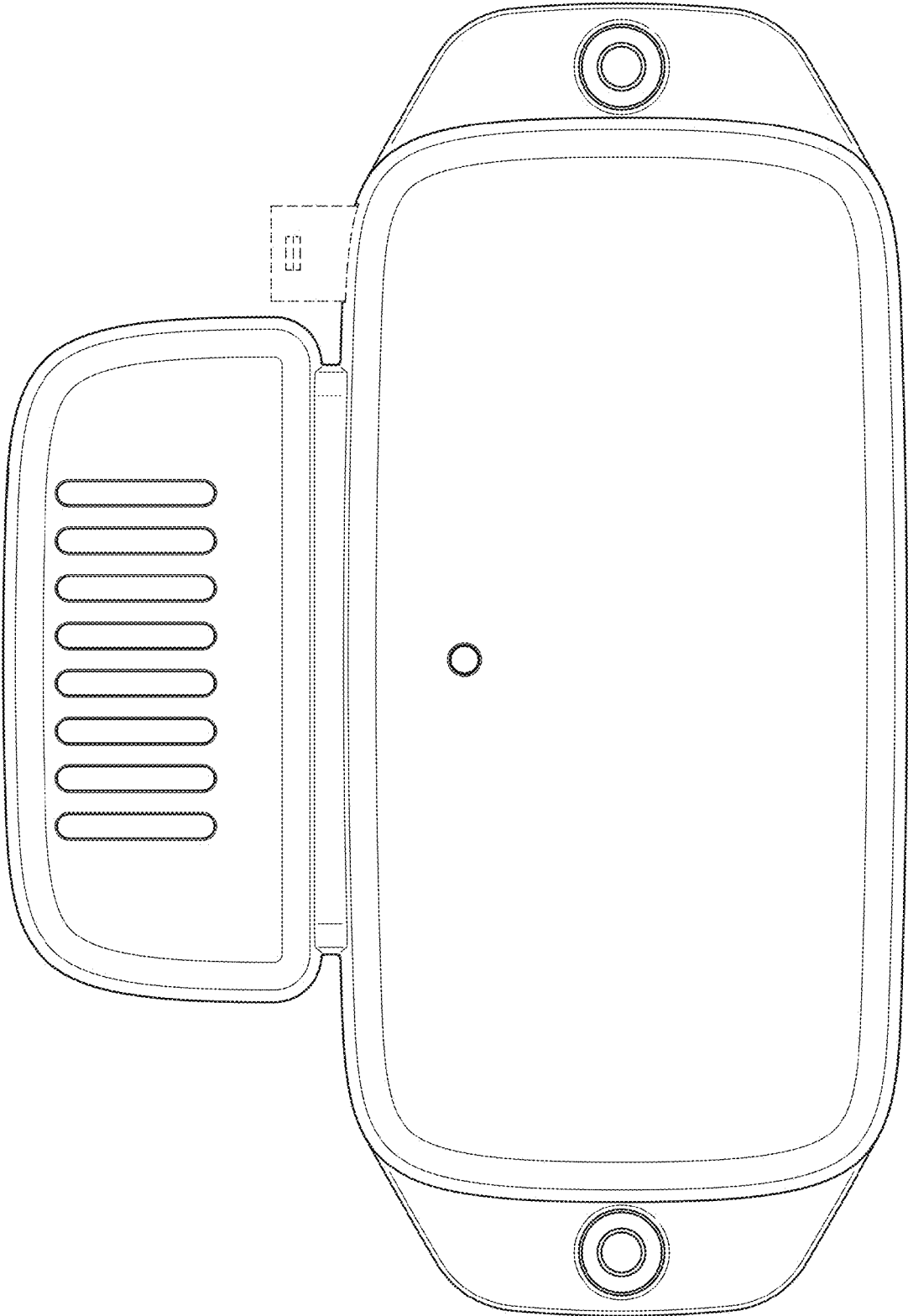

FIG. 15

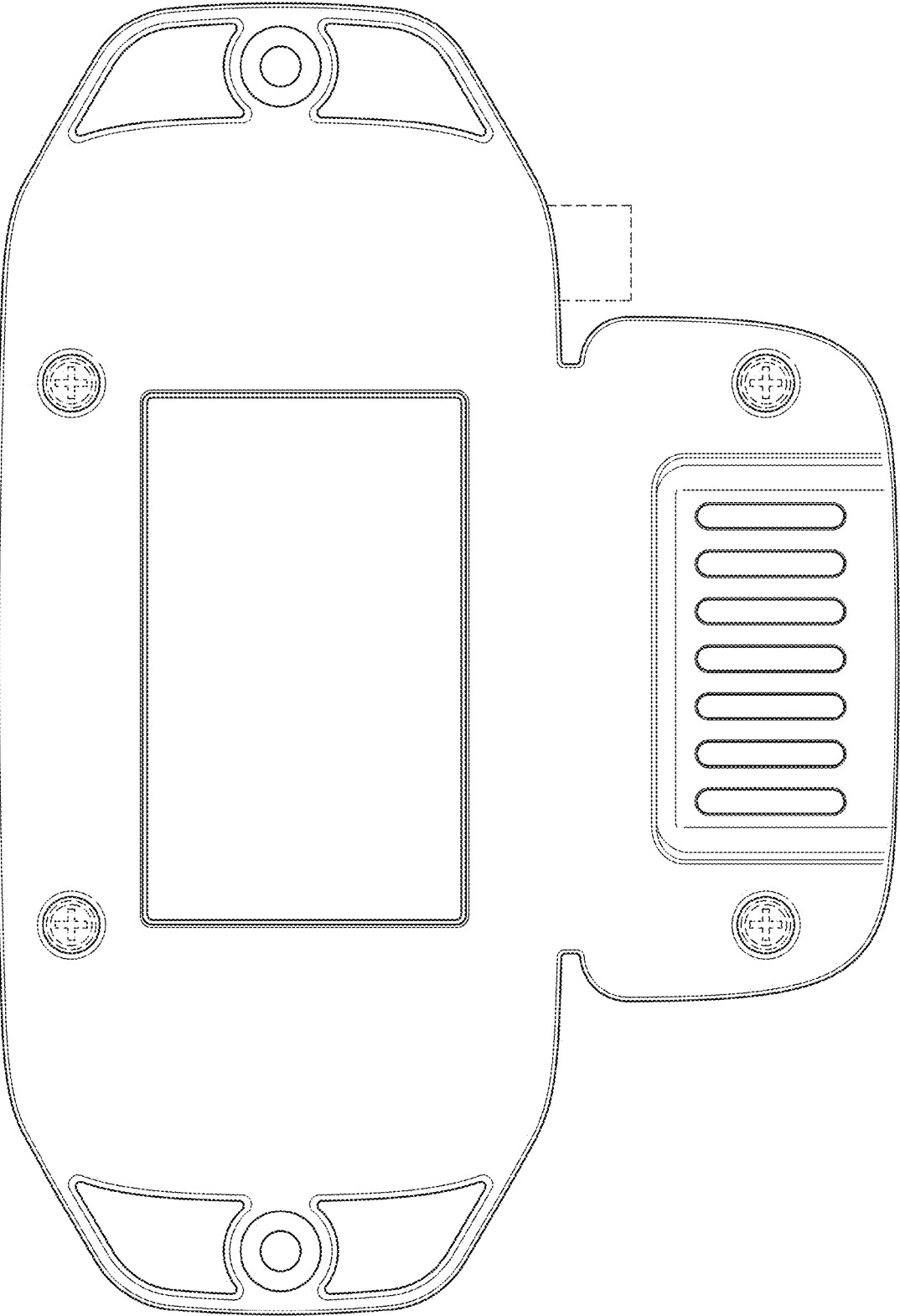

FIG. 16